



**McLAUGHLIN®**

2006 Perimeter Road. Greenville, SC 29605  
Toll Free: 800/435-9340 - Phone: 864/277-5870  
Fax: 864/235-9661 - Website address: [www.mightymole.com](http://www.mightymole.com)  
Email address: [mmole@mightymole.com](mailto:mmole@mightymole.com)

**Parts Manual  
V250 Vacuum Machine  
Part #E850250  
(Serial #250D062509346 - 250D010710431)**

© 2006 by McLaughlin Group, Inc.

40407

All rights reserved. No part of this manual may be reproduced in any form, or by any means without prior written permission of McLaughlin Group, Inc.



# Table of Contents

## PARTS

### SPOIL TANK AND FILTRATION

MANUAL DOOR .....	4
FILTRATION .....	6

### ENGINE COMPARTMENT

ENCLOSURE .....	10
ENGINE .....	12
BLOWER .....	14
WATER PUMP .....	20
REGULATOR .....	22
ELECTRICAL .....	26
HYDRAULIC PUMP .....	28

### WATER TANK AND ACCESSORIES

WATER TANKS - 50 GALLON SADDLE .....	30
--------------------------------------	----

### TRAILER AND SKID ASSEMBLY

HOSE REEL .....	32
TRAILER .....	34
SKID ASSEMBLY .....	36

### TOOLS

TOOL RACK .....	38
SUCTION TOOL .....	40
REDUCTION TOOL .....	42
WASH WAND .....	44
LAWN SWEEPER .....	46
VALVE BOX CLEAN OUT TOOL .....	48
SURFACE CLEANER .....	50
ROTARY LANCE .....	52

## ELECTRICAL SCHEMATICS

VACUUM DIESEL ENGINE .....	54
----------------------------	----

## MAINTENANCE MANUALS

ROOTS BLOWER .....	60
KUBOTA ENGINE .....	70

## WARRANTY

# Tank and Door Assembly

# V250

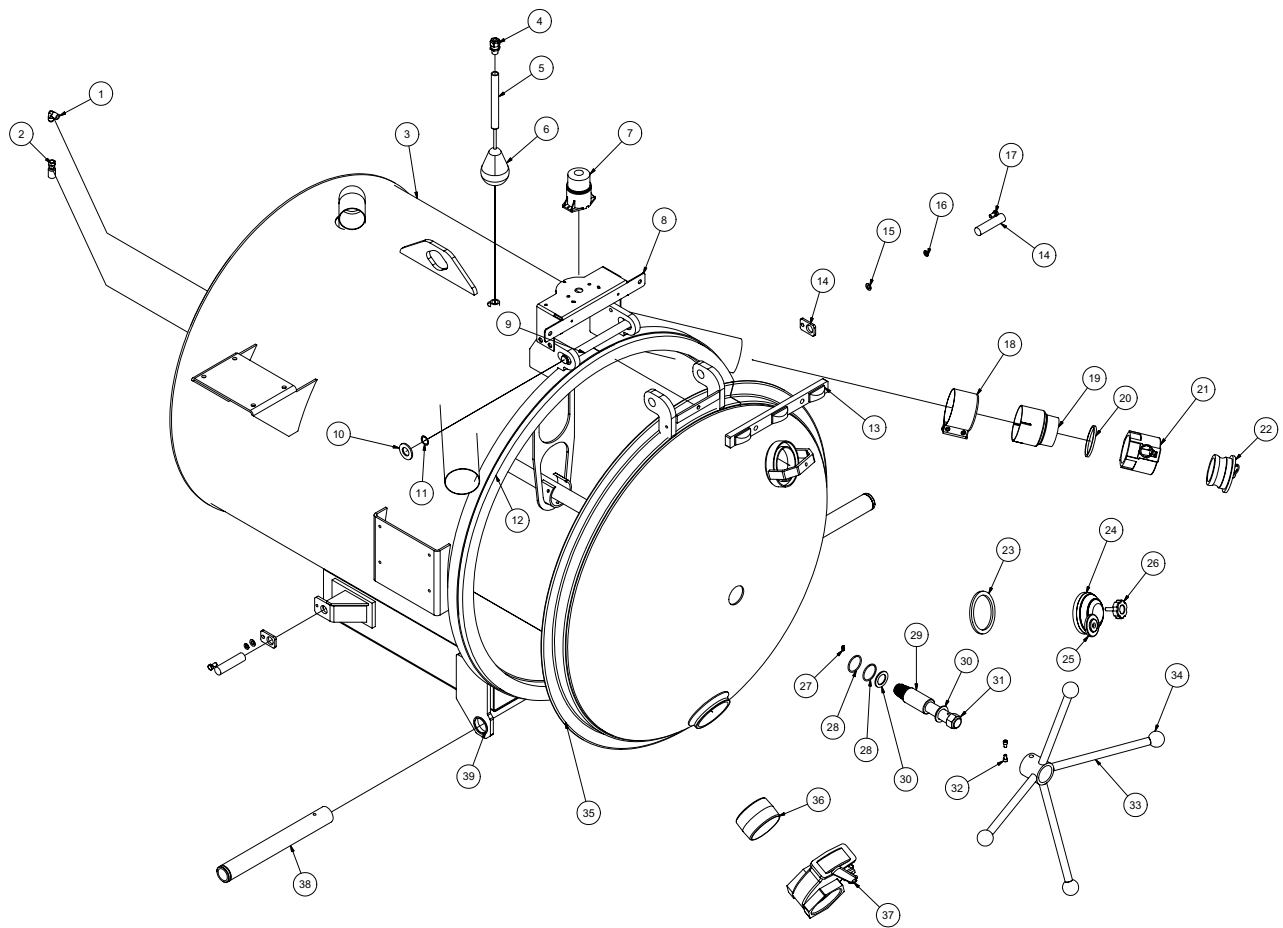

# Tank and Door Assembly

# V250

ITEM	QTY	PART NO.	DESCRIPTION
1	1	8030498	ELBOW, 3/8"MP - 3/8"MJ 90
2	1	T320040	FITTING, HOSE 6HO - 6FJ
3	1	8042364	TANK WELD'T V250
4	1	X000113	STRAIN RELIEF, 1/2"
5	1	8040769	HIGH LEVEL FLOAT SWITCH TUBE
6	1	8030531	HIGH LEVEL FLOAT SWITCH
	1	8041291	RUBBER BUSHING
7	1	8043139	STROBE LIGHT
8	1	8044634	STROBE LIGHT BRACKET
9	1	8040759	HINGE ROD
10	2	8030171	DOOR HINGE WASHER
11	2	8030362	1" SNAP RING
12	1	8041765	DOOR SEAL 42" DIA TANK
13	1	8041509	LIGHT CLEARANCE 3 BAR
14	2	8040753	CYLINDER PIN WELD'T
15	2	U200600	WASHER, FLAT 3/8"
16	2	U210060	WASHER, LOCK 3/8"
17	2	U000400	SCREW, HC 3/8 - 16 X .750
18	1	8030400	4" BAND CLAMP
19	1	8031044	ADAPTER 3" MNPT 4" ID
20	1	8031042	3" COUPLER GASKET
21	1	8030392	3" FEMALE COUPLER
22	1	8030393	3" COUPLER PLUG
	1	8041485	LANYARD CABLE
23	1	8032007	GASKET, 4" COUPLER
24	1	8031048	SIGHT GLASS
25	1	8031047	SIGHT GLASS PLATE
26	1	8031046	SIGHT GLASS HAND WHEEL
27	1	T500080	FITTING, GREASE 3/16"
28	2	W200120	O-RING 1 7/8 X 2 1/8 X 1/8 (225)
29	1	8040306	QL DOOR STRIKER
30	2	8030174	WASHER, DOOR HOLDER Q.L.
31	1	U120060	NUT, LOSK NY 1" - 8
32	2	U010040	SCREW, HSH 5/16 - 18 X .500
33	1	8040235	DOOR HANDLE, 250 - 1200
34	4	J400060	1 7/8" KNOB
35	1	8041069	DOOR WELD'T - 250 (42" DIA)
36	1	8030431	4" CLOSE NIPPLE
37	1	8030916	4" GATE VALVE
38	2	8040872	SPLIT PIVOT TUBE
39	2	8030363	SPIRAL SNAP RING, 2"

# Filtration

575

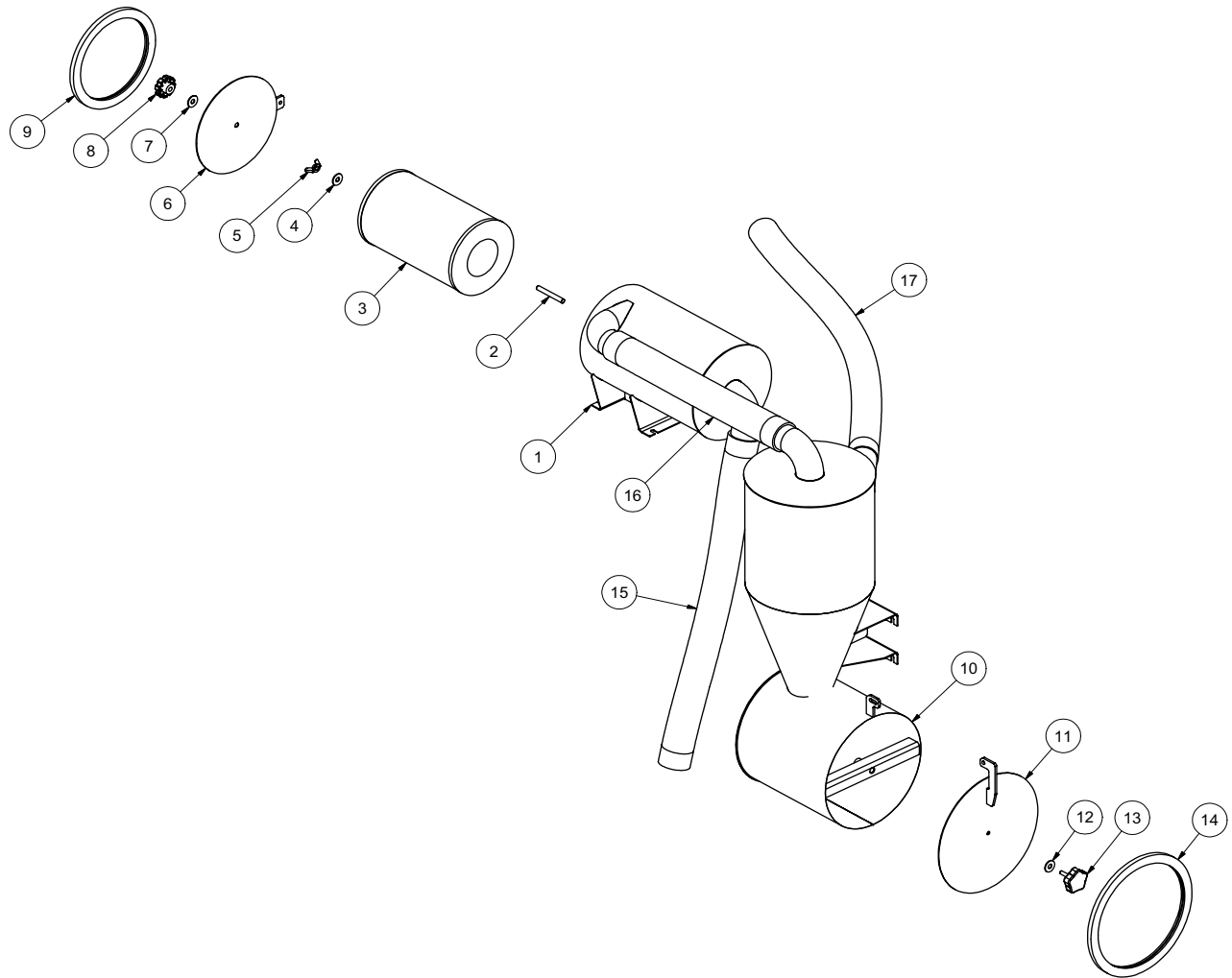

# Filtration

# 575

ITEM	QTY	PART #	DESCRIPTION
1	1	8042441	AIR FILTER HOUSING
	4	U000420	SCREW,HC 3/8-16 X 1.00
	8	U200600	WASHER,FLAT 3/8"
	4	U210061	NUT,HEX NY 3/8-16
2	1	8040302	THREADED ROD - 4" LG
3	1	8031178	FILTER, ELEMENT
4	1	U200100	WASHER, FLAT 1/2"
5	1	8041219	NUT, WIDE WING 1/2 - 13"
6	1	8041534	AIR FILTER HOUSING DOOR
	1	U000560	SCREW, HC 3/8-16 X 3.00
	2	U200600	WASHER,FLAT 3/8"
	1	U210061	NUT,HEX NY 3/8-16
7	1	8041232	WASHER, RUBBER BACKED 1/2"
8	1	8041218	KNOB, AIR FILTER
9	1	8041357	AIR FILTER HOUSING DOOR SEAL
10	1	8042440	CYCLONE SEPERATOR HOUSING
	4	U000420	SCREW,HC 3/8-16 X 1.00
	4	U200600	WASHER,FLAT 3/8"
	4	U210060	WASHER, LOCK
11	1	8041272	575/1025 CYCLONE DOOR
	1	U000460	SCREW, HC 3/8-16 X 1.50
	2	U200600	WASHER,FLAT 3/8"
	1	U210061	NUT,HEX NY 3/8-16
12	1	8041232	WASHER, RUBBER BACKED 1/2"
13	1	8041197	KNOB, CYCLONE
	1	U200600	WASHER,FLAT 3/8"
	1	U210061	NUT,HEX NY 3/8-16
14	1	8041444	CYCLONE DOOR SEAL
15	1	8043938	V500 AIR FILTER TO BLOWER HOSE KANAFLEX 3-126
	2	8042605	CLAMP HOSE T-BOLT 350
16	1	8043939	CYCLONE TO AIR FILTER HOSE KANAFLEX 3-20
	2	8042605	CLAMP HOSE T-BOLT 350
17	1	8043940	V500 TANK TO CYCLONE HOSE KANAFLEX 3-48
	2	8042605	CLAMP HOSE T-BOLT 350

# Enclosure Assembly

# 31HP LE

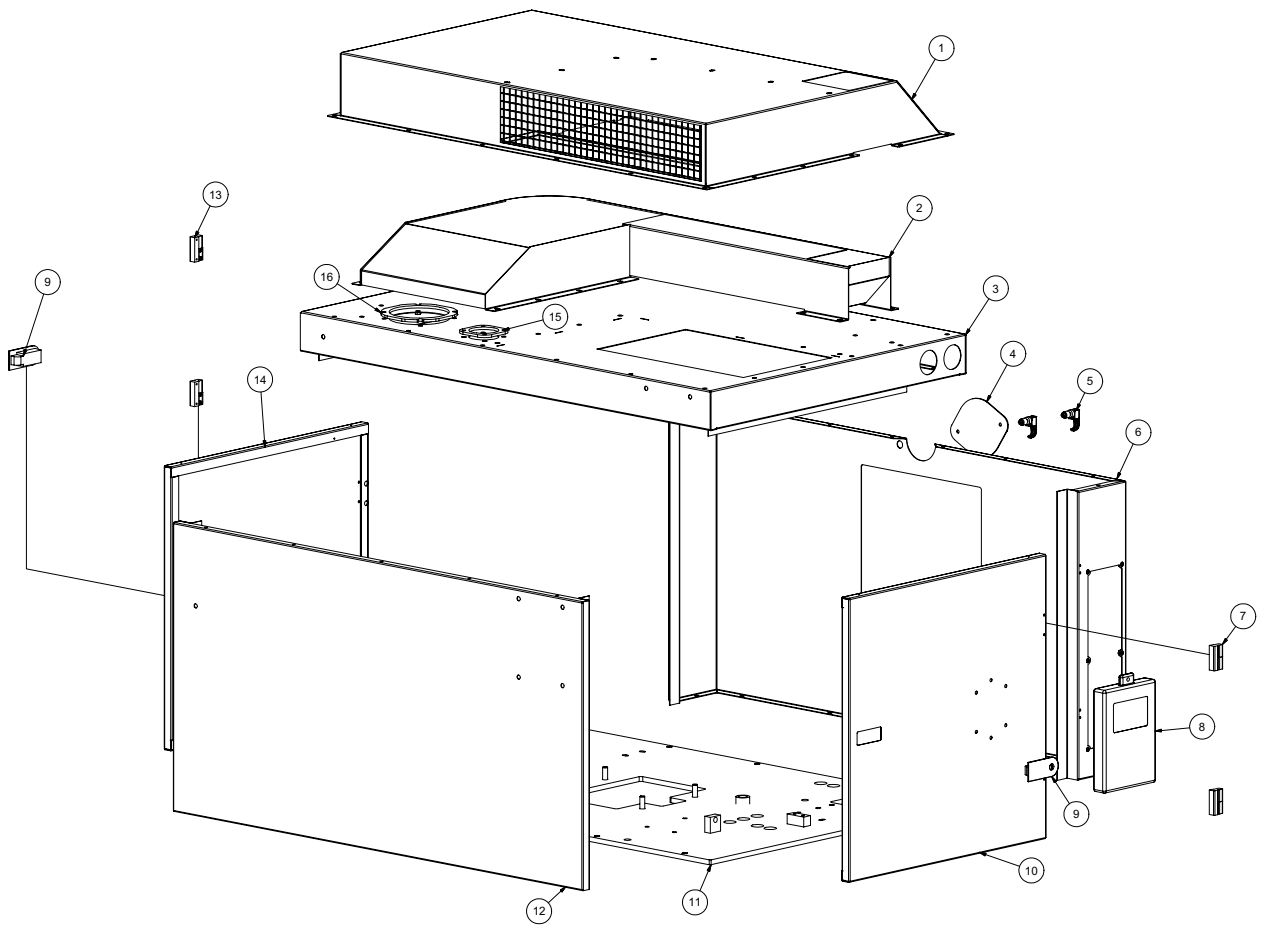



# Enclosure Assembly

# 31HP LE

ITEM	QTY	PART NO.	DESCRIPTION
1	1	8045125	INTAKE BOX 31LE - WELDMENT
2	1	8045096	HEAT SHIELD 31LE - WELDMENT
3	1	8045090	31LE PANEL TOP WELDMENT
4	1	8040592	ENCLOSURE RADIATOR COVER
5	2	8040334	SWELL LATCH
6	1	8045086	31LE PANEL FRONT WELDMENT
*	1	8045110	SOUND INSULATION OPPOSITE CONTROL PANEL
*	2	8045117	SOUND INSULATION LEFT OR RIGHT SIDE RADIATOR
*	1	8045118	SOUND INSULATION BELOW RADIATOR
*	1	8045115	SOUND INSULATION ABOVE RADIATOR
*	1	8045108	SOUND INSULATION UPPER FRONT PANEL
*	1	8045114	SOUND INSULATION CONTROL PANEL TOP
*	1	8045119	SOUND INSULATION CONTROL PANEL BOTTOM
7	2	8040588	OFFSET HINGE TYPE "A"
8	1	8030689	BOX, PLASTIC FOR SAFETY MANUAL
9	2	8040586	SEALED LEVER LATCH
10	1	8045091	31LE PANEL DOOR FOR MANUAL
*	1	8045111	SOUND INSULATION DOOR
*	1	8045112	SOUND INSULATION UPPER CURB SIDE
11	1	8045050	MAIN PLATE 31LE - WELDMENT
12	1	8045088	31LE PANEL REAR WELDMENT
*	2	8045107	SOUND INSULATION BACK PANEL
*	1	8045134	SOUND INSULATION UPPER BACK PANEL
13	2	8040589	OFFSET HINGE TYPE "B"
14	1	8045092	31LE PANEL DOOR
*	1	8045111	SOUND INSULATION DOOR
*	1	8045109	SOUND INSULATION UPPER STREET SIDE
15	1	8045143	FLANGE EXHAUST TOP PANEL WELDMENT
16	1	8044223	ENCLOSURE EXHAUST CLAMP PLATE

\* NOT SHOWN

# Enclosure Assembly

# 31HP RC

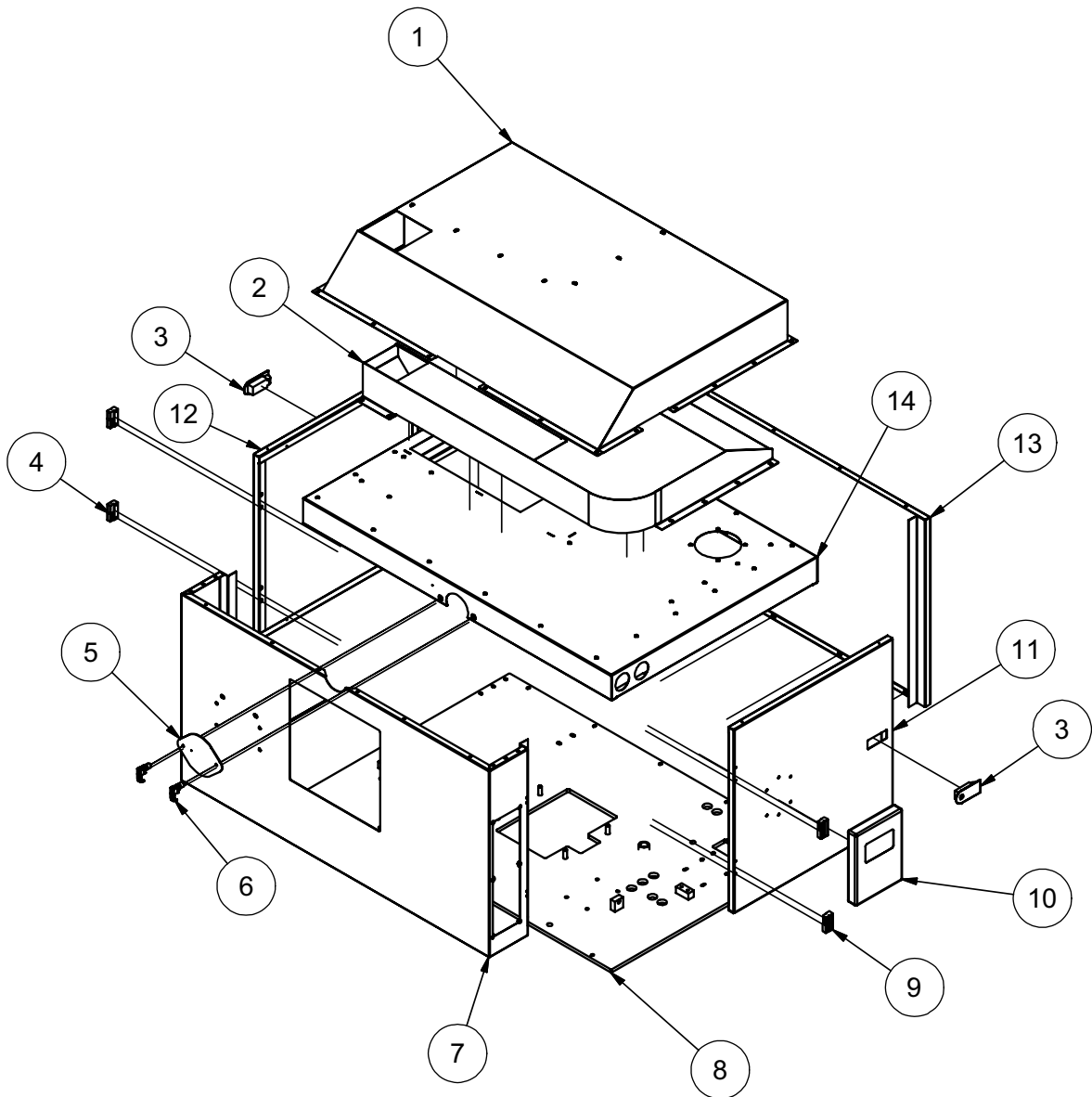

# Enclosure Assembly

# 31HP RC

ITEM	QTY	PART NO.	DESCRIPTION
1	1	8045125	INTAKE BOX 31LE - WELDMENT
2	1	8045096	HEAT SHIELD 31LE - WELDMENT
3	2	8040586	SEALED LEVER LATCH
4	2	8040588	OFFSET HINGE TYPE "A"
5	1	8040592	ENCLOSURE RADIATOR COVER
6	2	8040334	SWELL LATCH
7	1	8045455	31LE PANEL FRONT WELDMENT
*	1	8045110	SOUND INSULATION OPPOSITE CONTROL PANEL
*	2	8045117	SOUND INSULATION LEFT OR RIGHT SIDE RADIATOR
*	1	8045118	SOUND INSULATION BELOW RADIATOR
*	1	8045115	SOUND INSULATION ABOVE RADIATOR
*	1	8045108	SOUND INSULATION UPPER FRONT PANEL
*	1	8045114	SOUND INSULATION CONTROL PANEL TOP
*	1	8045119	SOUND INSULATION CONTROL PANEL BOTTOM
8	1	8045050	MAIN PLATE 31LE-WELDMENT
9	2	8040589	OFFSET HINGE TYPE "B"
10	1	8030689	BOX, PLASTIC FOR SAFETY MAIN
11	1	8045091	31LE PANEL DOOR WELDMENT
*	1	8045111	SOUND INSULATION DOOR
*	1	8045112	SOUND INSULATION UPPER CURB SIDE
12	1	8045092	31LE PANEL DOOR
*	1	8045111	SOUND INSULATION DOOR
*	1	8045109	SOUND INSULATION UPPER STREET SIDE
13	1	8045088	31LE REAR WELDMENT
	2	8045107	SOUND INSULATION BACK PANEL
	1	8045134	SOUND INSULATION UPPER BACK PANEL
14	1	8045524	31LE TOP WELDMENT(OPP)

# Engine Yanmar 3TNV82A

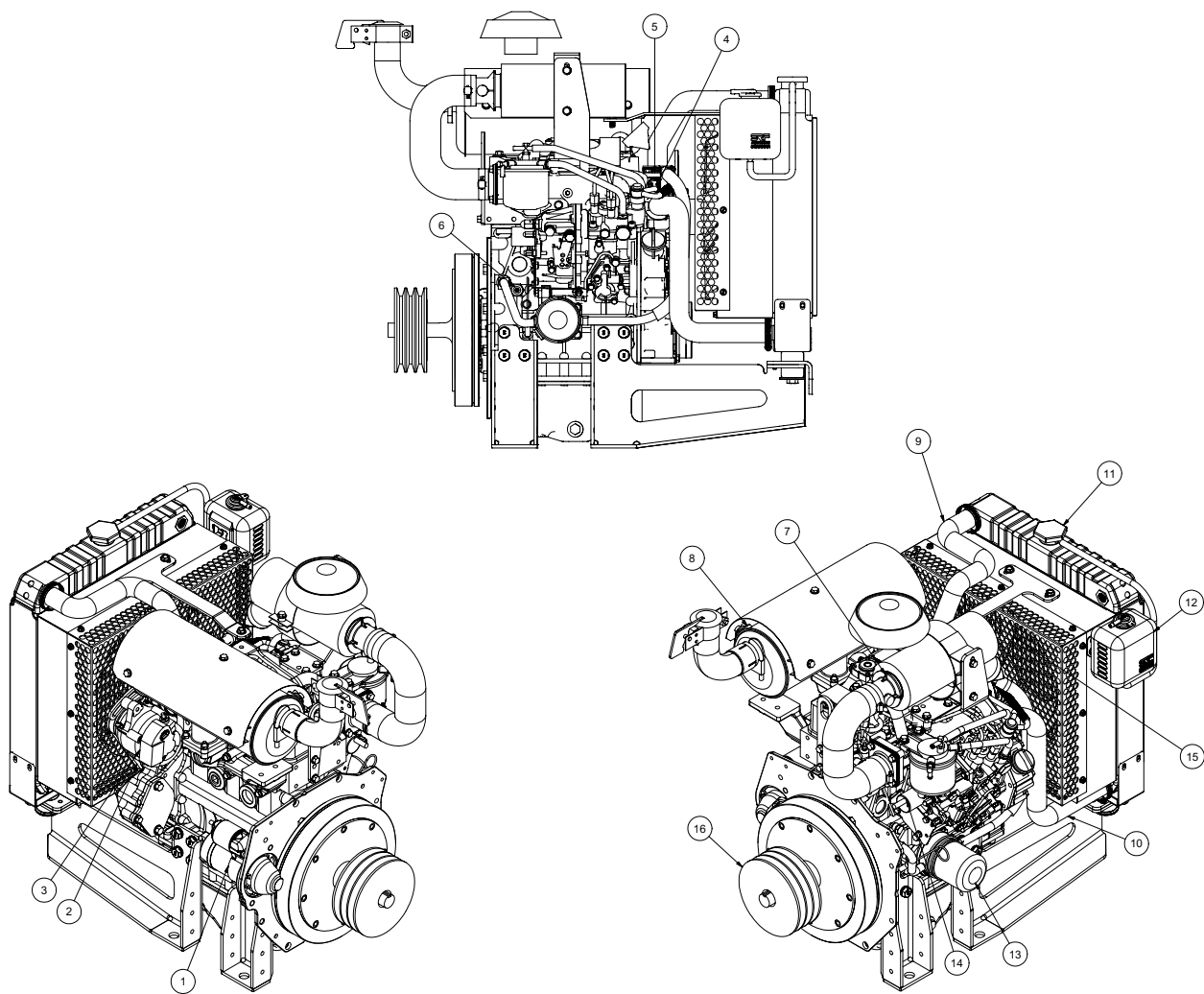

# Engine Yanmar 3TNV82A

ITEM	QTY	NUMBER	DESCRIPTION
1	1	8045083-1	STARTER
2	1	8045083-2	FAN BELT
3	1	8045083-3	ALTERNATOR
4	1	8045083-4	WATER TEMPERTURE SWITCH
5	1	8045083-5	THERMOSTAT
6	1	8045083-6	OIL PRESSURE SWITCH
7	1	8045083-7	AIR FILTER HOUSING
*	1	8045277	AIR FILTER ELEMENT
8	1	8045083-8	MUFFLER
*	1	8045278	MUFFLER GASKET
9	1	8045083-9	UPPER RADIATOR HOSE
10	1	8045083-10	LOWER RADIATOR HOSE
11	1	8045083-11	RADIATOR CAP
12	1	8045083-12	OVERFLOW TANK (SOLD WITH CAP)
13	1	8045083-13	OIL FILTER
14	1	8045083-14	FUEL SHUTOFF SOLENOID
15	1	8045083-15	FAN
16	1	8044548	SHEAVE, 7.75" OD SK 3-GROOVE
	1	8044516	BUSHING, 1 1/8" SK
*	1	8045279	THROTTLE SOLENOID
*	1	8045280	FUEL FILTER
*	1	8045281	FUEL PUMP
*	1	8045282	MURPHY SWITCH
*	1	8045283	KEY SWITCH
*	1	8045617	KEY
*	1	8045287	SOLENOID SPRING

\* NOT SHOWN

# Blower Assembly

31LE

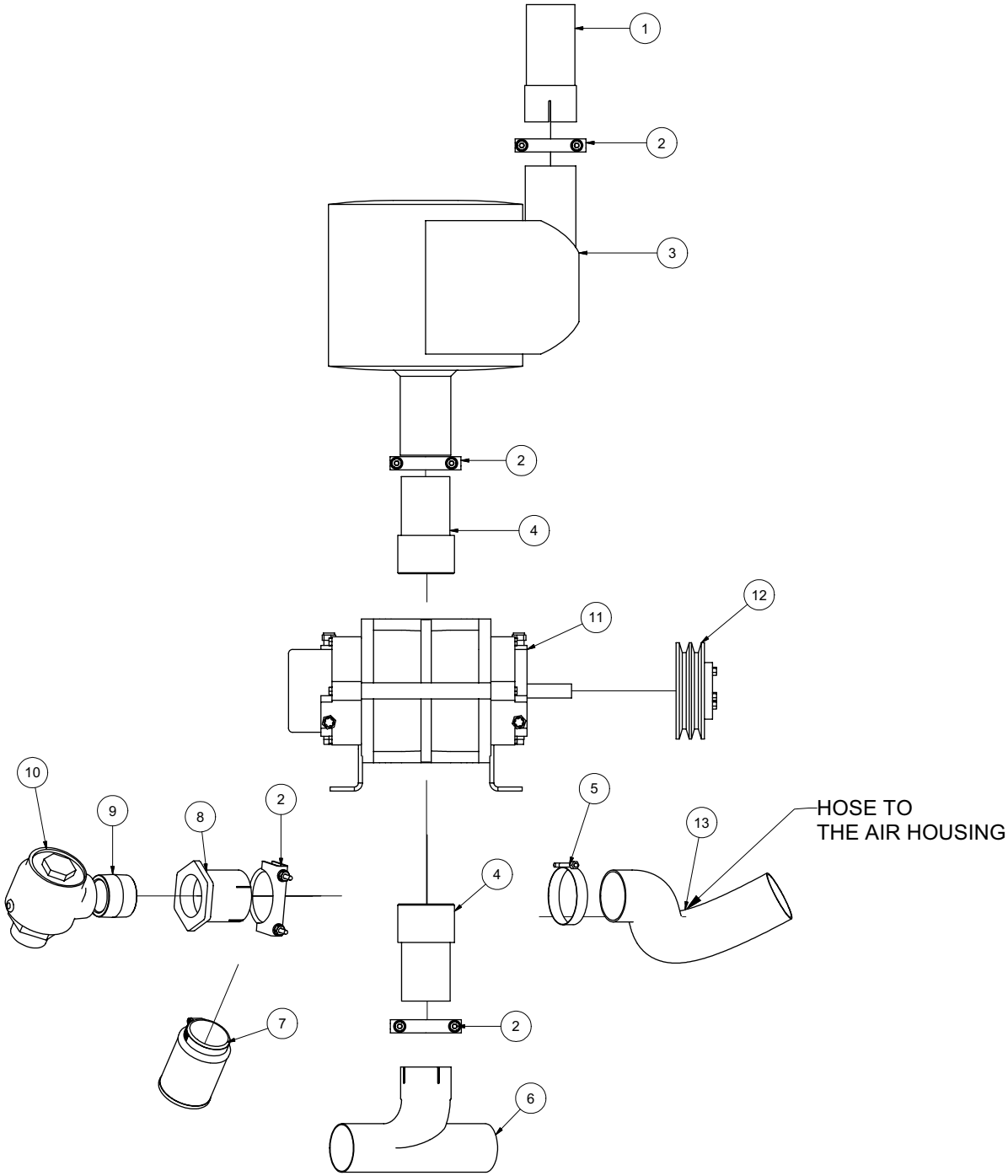

# Blower Assembly

# 31LE

ITEM	QTY	PART NO.	DESCRIPTION
1	1	8045205	BLOWER EXHAUST EXTENSION
2	4	8030395	3" U-BOLT CLAMP
3	1	8030332	SILENCER, 500CFM, COWL
4	2	8045238	UNION EXHAUST 3" OD-MNPT
5	1	8041250	BLOWER (MODEL 47)
	4	U000817	SCREW, HC 1/2" - 13 X 1"
	4	U210100	WASHER, LOCK 1/2"
	4	U200100	WASHER, FLAT 1/2"
6	1	8040484	6.95"OD SDS 2-GROOVE
	1	8040642	BUSHING 7/8" SDS
	1	U410042	KEY 3/16" X 3/16" X 2"
	1	8041797	RETAINER
	2	8041812	BX 52 BELT
7	1	8042605	CLAMP T-BOLT 3" (350)
8	1	8040336	HOSE VAC KANAFLEX 3-36"
9	1	8045476	WYE EXHAUST 3"OD-3"ID W/2"RED
10	1	8030409	2" CLOSE NIPPLE
11	1	8040340	FILTER, AIR FOR 2" KUNKLE VALVE
12	1	8030337	KUNKLE VALVE, 575CFM

REV.	PART NAME	DATE	BY

NOTES:  
 A- INSTALL ITEM #20 (SCREW) IN ASSEMBLY  
 C- 3-1/2 REQ'D SOC. HD. ON G.E. AND D.E.  
 E- REQ'D ON 42 ONLY  
 F- NUT TO BE TORQUED TO:  
 3-1/2---110 LB.FT.  
 4---190 LB.FT.  
 5---250 LB.FT.  
 G- USE RED LOCKTITE ON SET SCREW THREADS.

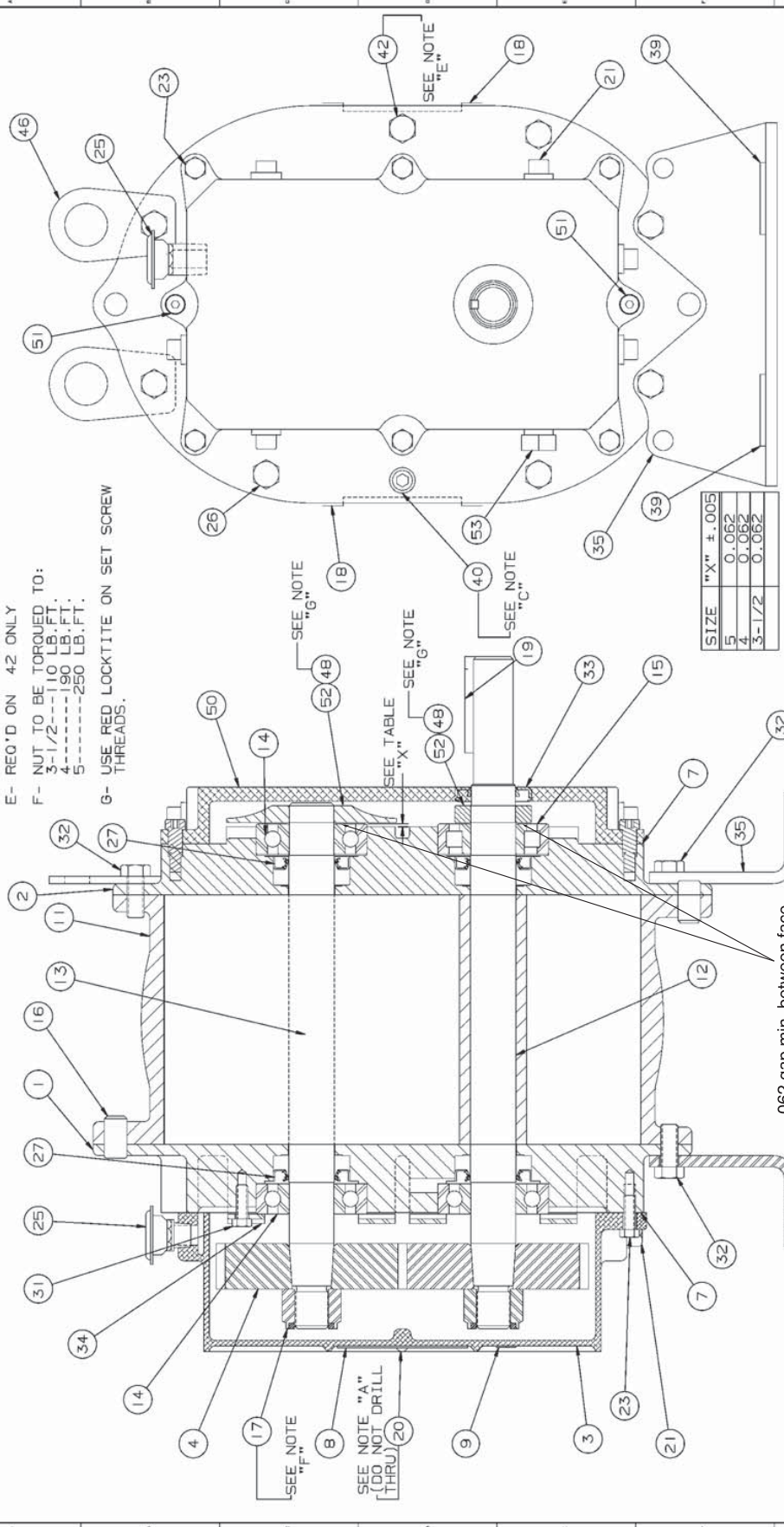

DATE	BY	CHKD	APP'D	REV.

COMP. NO. 100-0000  
 DRAWN BY 100-0000  
 CHECKED BY 100-0000  
 DATE FOR 100-0000  
 SCALE FULL  
 TITLE SECTIONAL ASSEMBLY  
 3-1/2 THRU 5" U-RAL DSL BLOWERS  
 URAL  
 Ural Diesel Engine, Inc.  
 Houston, TX, USA  
 T30356023

Assembly of Ural DSL Blowers with Splash Lubricated Drive End 3-5" Gear Diameter



**URAI-DSL Splash Lubricated Blowers  
4" Gear Diameter**

<b>Item #</b>	<b>Qty</b>	<b>Part #</b>	<b>Description</b>
1	1	8041250-1	Headplate Gear End
2	1	8041250-2	Headplate Drive End
3	1	8041250-3	Gearbox
4	2	8041250-4	Timing Gears
7	1	8041250-7	Gasket, Gear Box, DE Cover
11	1	8041250-11	Cylinder
12	1	8041250-12	Impeller & Shaft Drive
13	1	8041250-13	Impeller & shaft Driven
14	3	8041250-14	Bearing, Ball
15	1	8041250-15	Bearing, Roller
16	4	8041250-16	Pin, Dowel
17	2	8041250-17	Gear Nut
19	1	8041250-19	Key
21	3	8041250-21	Plug, Pipe
23	6	8041250-23	Screw Hex
25	1	8041250-25	Breather (Plug Vent)
26	*	8041250-26	Screw, Hex
27	4	8041250-27	Seal, Lip Bearing
31	4	8041250-31	Screw, Hex, Nylock
32	6	8041250-32	Screw, Hex
33	1	8041250-33	Seal Lip-Drive
34	2	8041250-34	Clamp Plate
35	2	8041250-35	Foot
39	4	8041250-39	Washer Mounting
40	2	8041250-40	Screw Socket
42	2	8041250-42	Screw Hex
48	4	8041250-48	DE Oil Slinger Set Screw
50	1	8041250-50	Drive End Cover
52	2	8041250-52	Drive End Oil Slinger
53	2	8041250-53	Oil Sight Glass

\*Quantities vary by blower.

# Water Pump Assembly

# 31LE

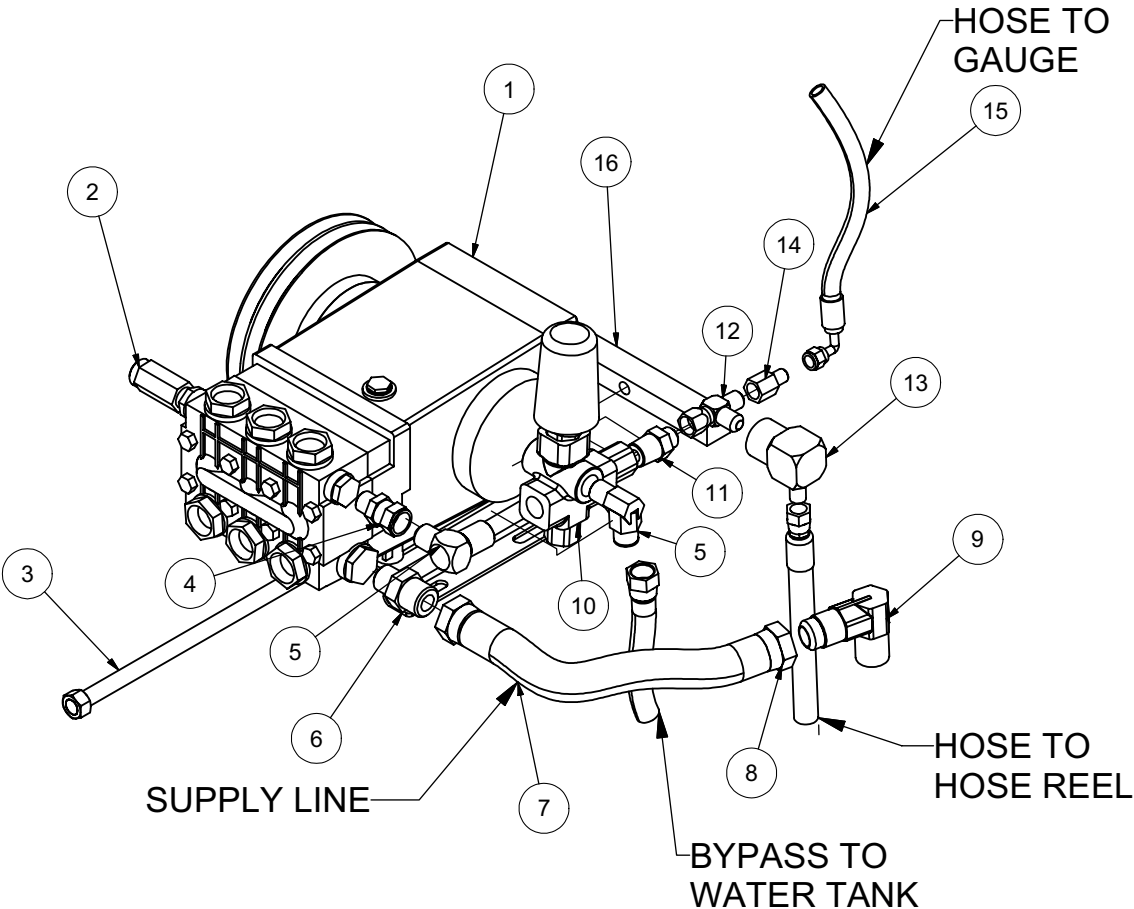

# Water Pump Assembly

# 31LE

ITEM	QTY	PART NO.	DESCRIPTION
1	1	8031388	PUMP, WATER T2021L & CLUTCH 5.6
	2	8045875	BELT, AX41
2	1	8030340	VALVE, RELIEF
3	1	8040751	ROD TIGHTENER WELD'T
4	1	T401125	REDUCER, 1/2"FJ - 3/8"MP
5	2	T401120	ELBOW, 3/8"MP-1/2"MJ
6	1	T400070	REDUCER, 1/2"MP - 3/4"MJ
7	1	8040972	HOSE VAC PUSH 12 - 8 1/2"
8	2	8030525	FITTING, PUSHLOCK #12
9	1	T401180	ELBOW, 90 3/4"MP - 3/4"MJ
10	1	8040177	VALVE, UNLOADER, PULSAR3
11	1	T400028	UNION, 3/8"MP - 3/8"MJ
12	1	T402153	TEE, 3/8"FJ - 3/8"MJ - 3/8"MJ
13	1	T401228	ELBOW, 3/8"MJ - 3/8"FJ
14	1	T400022	REDUCER, 3/8"FJ - 1/4"MJ
15	1	8044987	HOSE ASSY VAC 4-40 ST-90
	1	T320150	FITTING HOSE 4HO - 4FJ 90
	1	T320030	FITTING HOSE 4HO - 4FJ
16	1	8040893	TENSIONER BLOCK, ADJUSTING
*	1	8030372	WATER PRESSURE GAUGE 1/4NPT
*	1	T400110	UNION, 1/4FP - 1/4MJ

# Water Pump TS2021

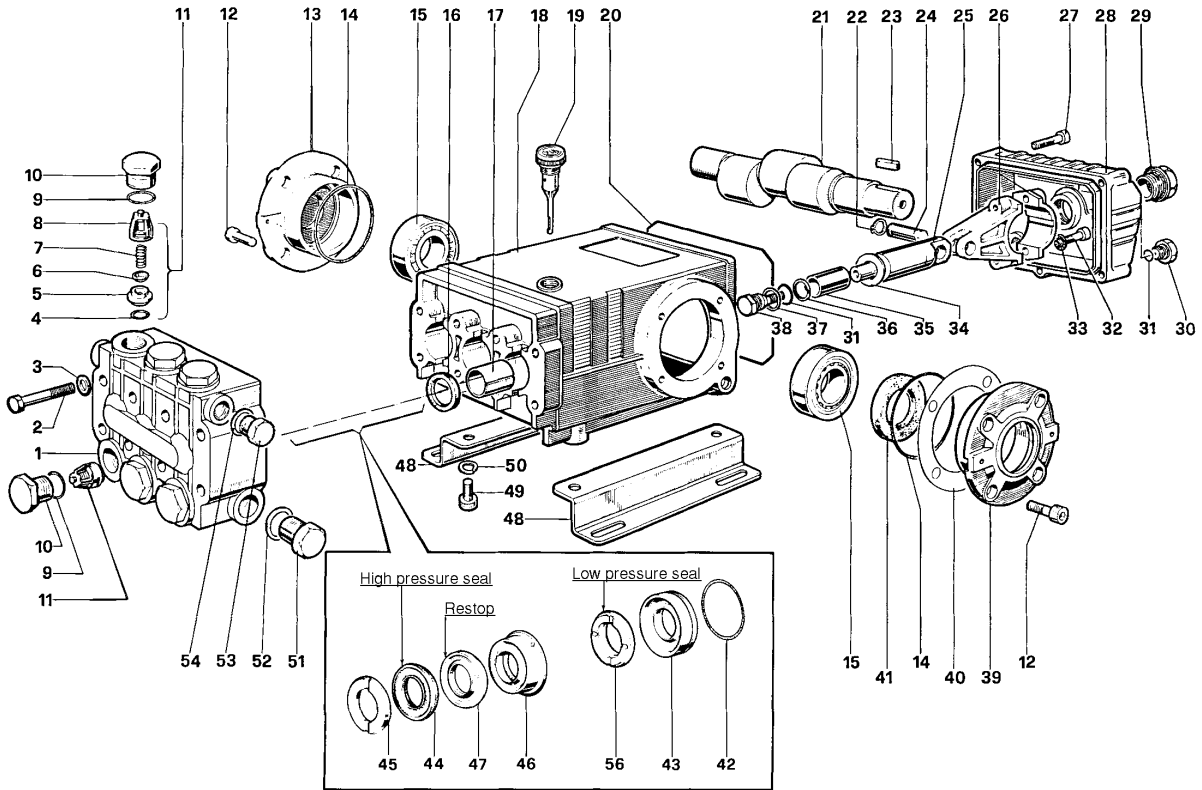

## TORQUE SPECS\*

\*Decrease torque by 20%  
if threads are lubricated

Position	Ft. Lbs.	N-M
2	22.1	29.9
10	73.7	99.9
12	14.7	19.2
27	7.3	9.9
29	13.2	17.9
30	14.7	19.2
32	14.7	19.2
38	14.7	19.2
49	29.4	39.8
51	29.4	39.8
53	29.4	39.8

# Water Pump TS2021

ITEM	QTY.	PART #	DESCRIPTION	KIT #	ITEM #'S INCL'D IN KIT	NO. OF ASSY IN KIT	NO. OF CYL KIT WILL SERVICE
1	1	8031280-1	Manifold	8031280-KIT1	4, 5, 6, 7, 8 (11)	6	3
2	8	8031280-2	Screw, M8 x 70	8031280-KIT2	16	3	3
3	8	8031280-3	Washer, M8 x 4	8031280-KIT3	41	2	0
4	8	8031280-4	O-ring, .674 x .103	8031280-KIT4	9, 10	6	3
5	6	8031280-5	Seat, Valve	8031280-KIT5	9, 10	6	3
6	6	8031280-6	Plate, Valve	8031280-KIT6	31, 34	3	3
7	6	8031280-7	Spring		36, 37, 38		
8	6	8031280-8	Guide, Valve	8031280-KIT7	45	6	3
9	6	8031280-9	O-ring,.797x.103	8031280-KIT10	42, 43	3	3
10	6	8031280-10	Cap	8031280-KIT28	42, 43, 44,	1	1
11	6	8031280-11	Valve Assembly		45, 45, 47, 56		
12	8	8031280-12	Screw, M8 x 16	8031280-KIT69	44, 47, 56	3	3
13	1	8031280-13	Cover, Crankcase	8031280-KIT71	46, 47	3	3
14	2	8031280-14	O-ring, 2.675 x .103				
15	2	8031280-15	Bearing, Roller				
16	3	8031280-16	Seal, Oil				
17	3	8031280-17	Bushing				
18	1	8031280-18	Crankcase				
19	1	8031280-19	Oil Dip Stick				
20	1	8031280-20	O-ring, Cover				
21	1	8031280-21	Crankshaft				
22	6	8031280-22	Ring, Snap				
23	1	8031280-23	Key				
24	3	8031280-24	Pin, Wrist				
25	3	8031280-25	Guide, Plunger				
26	3	8031280-26	Rod, Connecting				
27	5	8031280-27	Screw, M6 x 30				
28	1	8031280-28	Cover, Crankcase				
29	6	8031280-29	Oil Indicator				
30	1	8031280-30	Cap				
31	4	8031280-31	O-ring,.426x.070				
32	6	8031280-32	Screw, M8 x 35				
33	6	8031280-33	Washer, M8.4				
34	3	8031280-34	Washer, M14				
35	3	8031280-35	Plunger (20 mm)				
37	3	8031280-37	Washer				
38	3	8031280-38	Screw, Plunger				
39	1	8031280-39	Cover, Crankcase				
40	2	8031280-40	Shim				
41	1	8031280-41	Seal, Oil				
42	3	8031280-42	O-ring, 1.364x.070				
43	3	8031280-43	Retainer, Packing				
44	3	8031280-44	Packing				
45	3	8031280-45	Ring, Head, M20				
46	3	8031280-46	Intermed. Ring				
47	3	8031280-47	Testop Ring				
48	2	8031280-48	Pump Feet				
49	4	8031280-49	Screw, M10 x 18				
50	4	8031280-50	Washer, M10.2				
51	1	8031280-51	Cap				
52	1	8031280-52	Washer, M21.5				
53	1	8031280-53	Cap				
54	1	8031280-54	Washer, M17.5				
56	3	8031280-56	Seal,Low Press,20mm				

VACASSY325

# Unloader Valve YU2140

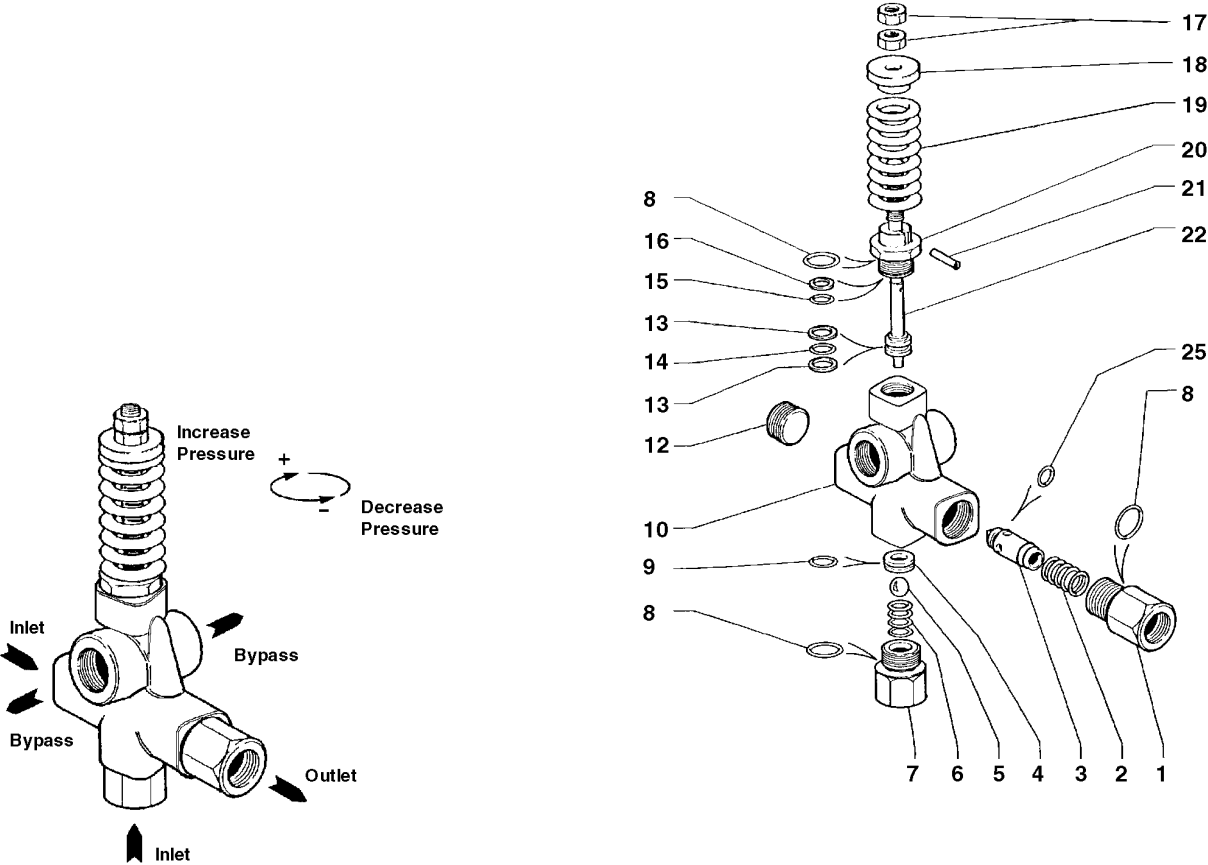

# Unloader Valve YU2140

ITEM	QTY	PART #	DESCRIPTION
1	1	8030341-1	OUTLET CONNECTION
2	1	8030341-2	SPRING
3	1	8030341-3	CHECK VALVE
4	1	8030341-4	SEAT
5	1	8030341-5	SS BALL
6	1	8030341-6	SPRING
7	1	8030341-7	INLET CONNECTION
8	2	8030341-8	O-RING
9	1	8030341-9	O-RING
10	1	8030341-10	VALVE HOUSING
12	1	8030341-12	PLUG
13	2	8030341-13	BACK RING
14	1	8030341-14	O-RING
15	1	8030341-15	O-RING
16	1	8030341-16	BACK RING
17	1	8030341-17	NUT
18	1	8030341-18	SPRING GUIDE
19	1	8030341-19	SPRING-GREEN (YU2140)
20	1	8030341-20	PISTON HOUSING
21	1	8030341-21	PIN
22	1	8030341-22	PISTON
25	1	8030341-25	O-RING

# Control Panel

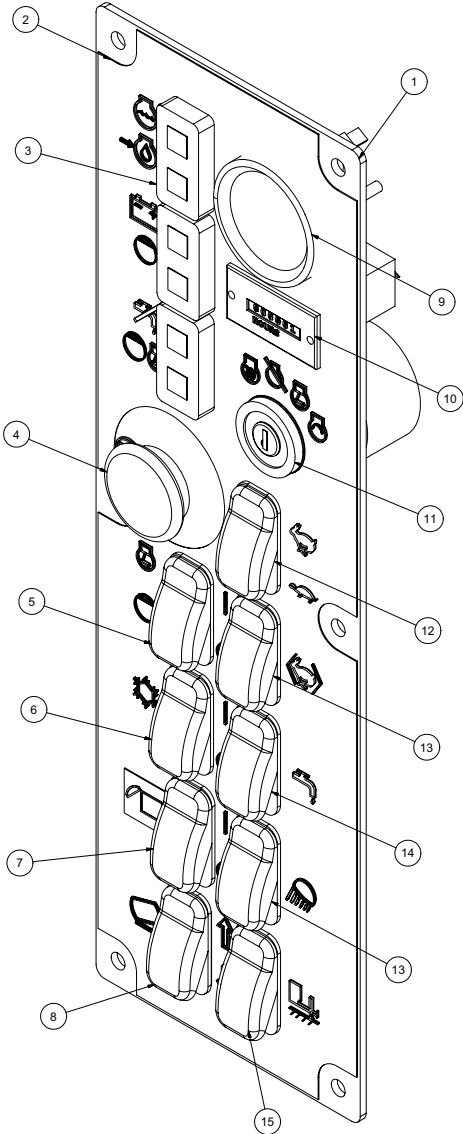
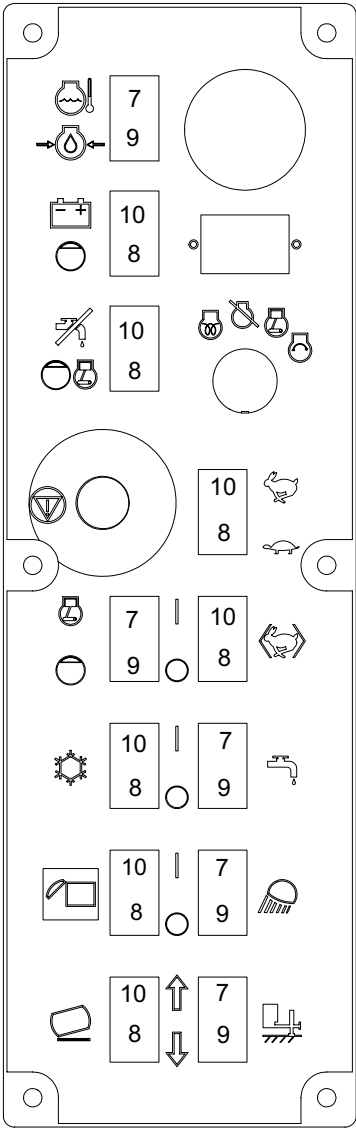



# Control Panel

ITEM	QTY	PART NO.	DESCRIPTION
1	1	8043128	CONTROL PANEL - MAIN PLATE
2	1	J200031	DECAL - CONTROL PANEL
3	3	X000260	LIGHT LED DUAL PANEL
4	1	X000280	E-STOP
5	1	X000273	ROCKER SWITCH SPST (ON) NONE -OFF
6	1	X000272	ROCKER SWITCH DPST (ON) NONE -ON
7	1	X000272	ROCKER SWITCH DPST (ON) NONE - ON
8	1	X000274	ROCKER SWITCH DPDT (ON) OFF (ON)
9	1	X100001	FUEL GAUGE
10	1	X000300	HOUR METER
11	1	8030458	IGNITION SWITCH
12	1	X000271	ROCKER SWITCH DPST ON - ON
13	2	X000270	ROCKER SWITCH SPST ON -OFF
14	1	X000270	ROCKER SWITCH SPST ON -OFF
	1	X000271	ROCKER SWITCH DPST ON -ON
15	1	X000290	ROCKER SWITCH PLUG
	1	X000274	ROCKER SWITCH DPDT (HYD. JACK OPTION)
*	1	8030829	KEY, IGNITION - KUBOTA

\* NOT SHOWN

# Electrical Control Bracket

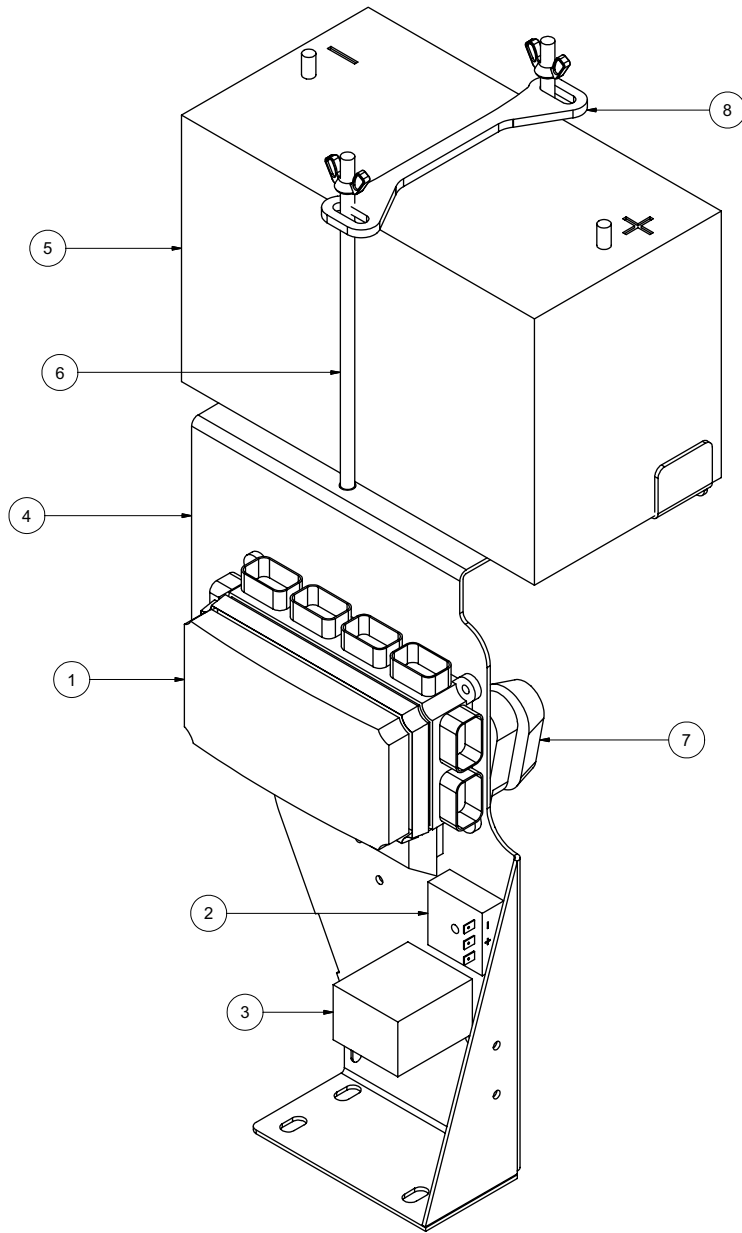

# Electrical Control Bracket

ITEM	QTY	PART NO.	DESCRIPTION
1	1	X000213	BUSSMAN VEC
	7	X000205	FUSE 5A
	2	X000206	FUSE 10A
	2	X000207	FUSE 20A
	3	X000237	FUSE 30A
	1	X000236	CIRCUIT BREAKER 20A
	1	X000210	CIRCUIT BREAKER 30A
	6	X000209	RELAY 35A/25A
	5	X000208	DIODE 6A
2	1	8042282	SWITCH, DELAY RELAY
3	1	X000240	RELAY TIME 30 SECOND
4	1	8043127	CONTROL PANEL - HARNESS MTG PLATE
5	1	X400050	BATTERY, 31-MHD WORKAHOLIC
6	2	8043742	BATTERY HOLD DOWN ROD ASSY
7	1	8043800	FUSE HOLDER AMG
	1	8043801	FUSE 250A AMG
8	1	8050016	BATTERY HOLD DOWN
*	1	X200005	HARNESS VAC CONTROL
*	1	X300222	BATTERY GROUND CABLE
*	1	X300219	BATTERY HOT CABLE 18"
*	1	X300220	ENGINE TO FUSE HOT 1GA 60"
*	1	X300221	HYD PUMP TO FUSE HOT 1GA 36"
*	1	X300221	ELEC CONTROL BOX TO FUSE HOT 1GA 36"
*	1	X300222	ELEC CONTROL BOX GROUND 1GA 18"
*	1	X300224	ENGINE GROUND 1GA 21"
*	1	X300225	HYD PUMP GROUND 1GA 24"

\* NOT SHOWN

# Hydraulic Pump w/ Bracket

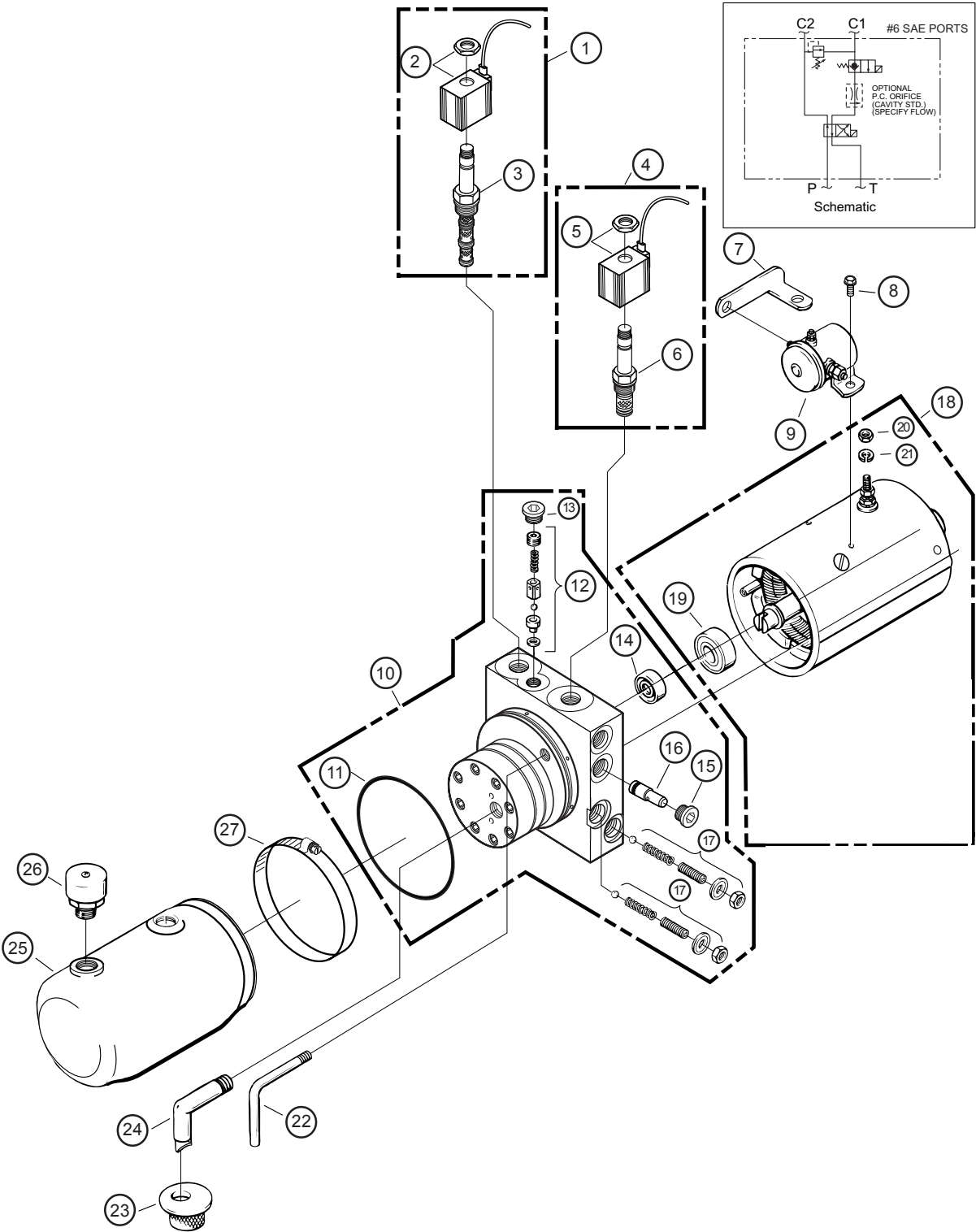

# Hydraulic Pump w/ Bracket

ITEM	QTY	NUMBER	DESCRIPTION
	1	8040486	HYDRAULIC PUMP 12V 3QT
		8045355	HYDRAULIC PUMP 12V 6QT (HYDRAULIC DOOR OPTION)
	2	U000420	SCREW, HC 3/8"-16 X 1
	2	U210060	WASHER, LOCK 3/8"
	2	U200600	WASHER, FLAT 3/8"
	2	T400037	UNION 6MB-6MJR
	2	8040973	HOSE ASSY VAC 6-20 ST-90
	2	T400391	BULKHEAD 6MP 6MP
1	1	8041601-14	VALVE, 4 WAY - 2 POSITION (12V)
2	1	8041601-15	COIL, 10 VDC GROUNDED W/DEUTSCH CONN
3	1	8041601-16	CARTRIDGE, 4 WAY - 2 POSITION
4	1	8041601-17	VALVE, 2 WAY - 2 POSITION (12V) GROUNDED
5	1	8041601-18	COIL, 10 VDC, 2 WAY-2 POS GRND W/DEUTSCH CONN
6	1	8041601-19	VALVE 12V HYD 2 WAY-2 POS
7	1	8041601-20	STRAP, MOTOR SOLENOID CONNECTING
8	2	8041601-21	SCREW, RND HD MACH 10-32 X 1/4"
9	1	8041601-22	SWITCH, SOLENOID 12VDC, 3 POST GRND
10	1	8041601-23	PUMP ASSY
11	1	8041601-24	O-RING INDUST 3-5/8 X 3-7/8 X 1/8
12	1	8041601-25	PARTS KIT-VALVE ASSY, POPPET/BALL CHECK
13	1	8041601-26	PLUG
14	1	8041601-27	SEAL
15	1	8041601-28	PLUG, #8 SAE
16	1	8041601-29	VALVE, PRESS, COMP ORIFICE
17	2	8041601-30	PARTS KIT, RELIEF VALVE
18	1	8041601-31	MOTOR, ELECTRIC 12VDC
19	1	8041601-32	BEARING, BASE, MOTOR
20	1	8041601-33	NUT, HEX 5/16-24
21	1	8041601-34	WASHER, LOCK 5/16"
	2	8041601-38	SCREW, HEX HEAD, 1/4-20 X 1-3/8"
	1	8041601-41	PLUG, 3/8" NPTF
22	1	8041601-42	TUBE, RETURN (1/8")
23	1	8041601-43	SCREEN, FILTER (SUCTION)
24	1	8041601-44	TUBE, FILTER SUCTION 3/8 NPT 90 DEG
25	1	8041601-45	6QT RESEVOIR POLY
	*	8040486-45	3QT RESEVOIR POLY
	*	8041601-48	4.5QT RESEVOIR POLY
26	1	8041601-46	PLUG, VENT, 3/8" NPT
27	1	8041601-47	CLAMP, HOSE WORM GEAR (IN SERIES)
*	1	X200002	HYDRAULIC PUMP WIRE HARNESS
*	1	8043499	HYDRAULIC PUMP MOUNT
		8044297	HYDRAULIC PUMP MOUNT (REVERSE FLOW)
		8045336	HYDRAULIC PUMP MOUNT (412 BLOWER)

\* NOT SHOWN



# Water Tank Assembly 50Gallon Saddle Tanks

ITEM	QTY	PART NO.	DESCRIPTION
1	2	8034151	50 GALLON WATER TANK
2	2	8034151-1	TANK LID
3	4	U010017	U-BOLT 1 1/2" X 1/4-20
4	2	8030351	BALL VALVE, STEEL 6FP
5	8	U120100	NUT, LOCK 1/4-20
	8	U200020	WASHER, FLAT 1/4"
6	1	8042412	HOSE REEL SUPPLY HOSE
7	1	8043927	HOSE REEL SP 3/8"
	4	U000420	SCREW, HC 3/8"-16X1.0
	8	U200060	WASHER, FLAT 3/8"
	4	U210060	WASHER, LOCK 3/8"
	4	U100060	NUT, HEX 3/8"-16
	1	8041830	HOSE 3/8" X 30'
	*	8030842-100	HOSE 3/8" X 100' (OPTIONAL)
	1	8030526	QUICK DISCONNECT 1/4" FEMALE
	1	8030504	REDUCER 3/8"FP - 1/4"MP
8	1	8043094	HOSE REEL BRACKET
9	4	8043758	STRAP, EYEBOLT 1" X 55" OAL
10	2	8040952	SADDLE FRAME
11	2	T405065	PLUG, 3/4" MP
12	2	8041044	BULKHEAD, 1 1/4" FNPT - PLASTIC
13	2	8041526	ELBOW, 45 1-1/4" STREET
14	4	8041312	FITTING, HOSE BARB 1 1/4"
15	2	8042940	HOSE VAC CLEAR VINYL 1 1/4-18
16	1	8041309	ELBOW, 1 1/4FP-1 1/4FP
17	1	8041310	TEE, 1 1/4FP-1 1/4FP-1 1/4FP
18	1	T403100	REDUCER, 20MP-12FP
19	1	T400101	UNION, 12FJ-12MP
20	1	T400100	UNION, 12MJ-12MP
21	1	T000185	BALL VALVE, BRASS 3/4" FP
22	1	T404060	UNION, 16MP-12MP
23	1	8040186	STRAINER
24	1	T400450	UNION, 12MJ-16MP
25	1	8041058	HOSE VAC PUSH 12-36
	2	8030525	FITTING, HOSE #12FJ PUSH LOCK
	1	8030518	1/2" BULKHEAD 45 DEG
26	1	8031126	REDUCER, 1/4"FP - 3/8"MJ
27	1	8030340	SAFETY RELIEF VALVE
28	1	T402153	TEE 6MJ-6MJ-6FJ
29	1	8040670	BALL VALVE BRACKET
30	2	T401102	ELBOW 6MJ 6MP
31	1	8031125	UNION 4FP 6FJ
32	1	8041059	HOSE VAC PUSH 8-66
	2	8030524	1/2" PUSH LOCK FITTING
33	1	8043664	BALL VALVE TO WATER PUMP HOSE #6-36 ST-90
34	1	8043949	BALL VALVE TO TANK CLEANOUT HOSE #6-215 ST-90
35	1	8041477	HOSE REEL TO BALL VALVE HOSE #6-140 ST-ST
36	1	T400803	UNION, 6MP-6MJ

# Hose Reel Assembly

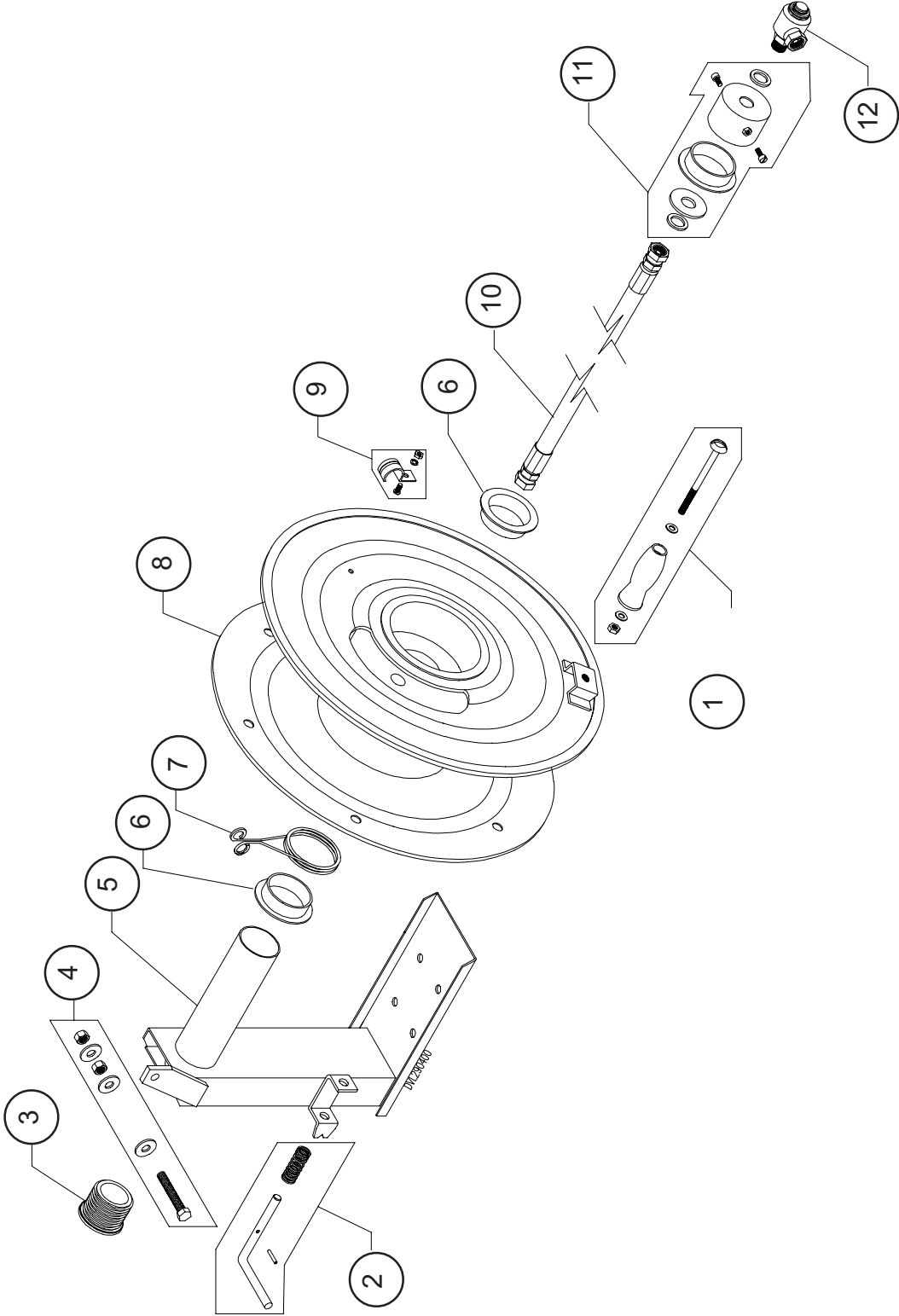



# Hose Reel Assembly

ITEM	QTY	NUMBER	DESCRIPTION
	1	8043927	HOSE REEL, SP 3/8" X 150'
1	1	8043927-1	KIT-HOSE REEL HANDLE W/HARDWARE
2	1	8043927-2	KIT-LOCKING LATCH AND SPRING
3	1	8043927-3	KIT-HOSE GUIDE
4	1	8043927-4	KIT-SCREW, WASHER, BOLT SET
5	1	8043927-5	KIT-BASE
6	1	8043927-6	KIT-BUSHINGS (2)
7	1	8043927-7	KIT-BREAKING SPRING
8	1	8043927-8	KIT-REEL
9	1	8043927-9	KIT-HOSE CLAMP AND SCREW SET
10	1	8042412	HOSE VAC ASSY 6-33 ST-ST FNPT
11	1	8043927-11	KIT-SWIVEL MOUNTING COLLAR
12	1	8043927-12	KIT-3/8" HIGH PRESSURE SWIVEL 5000 PSI

# Trailer Assy 250

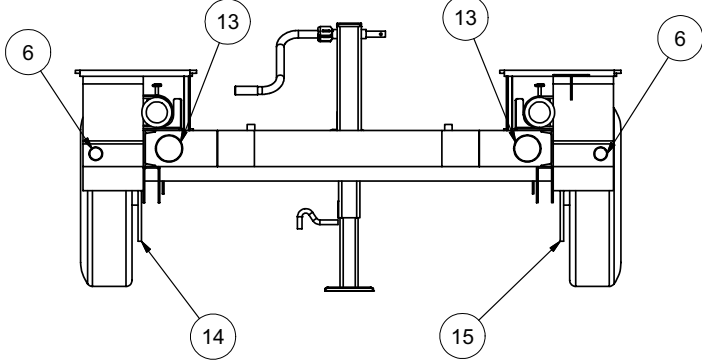
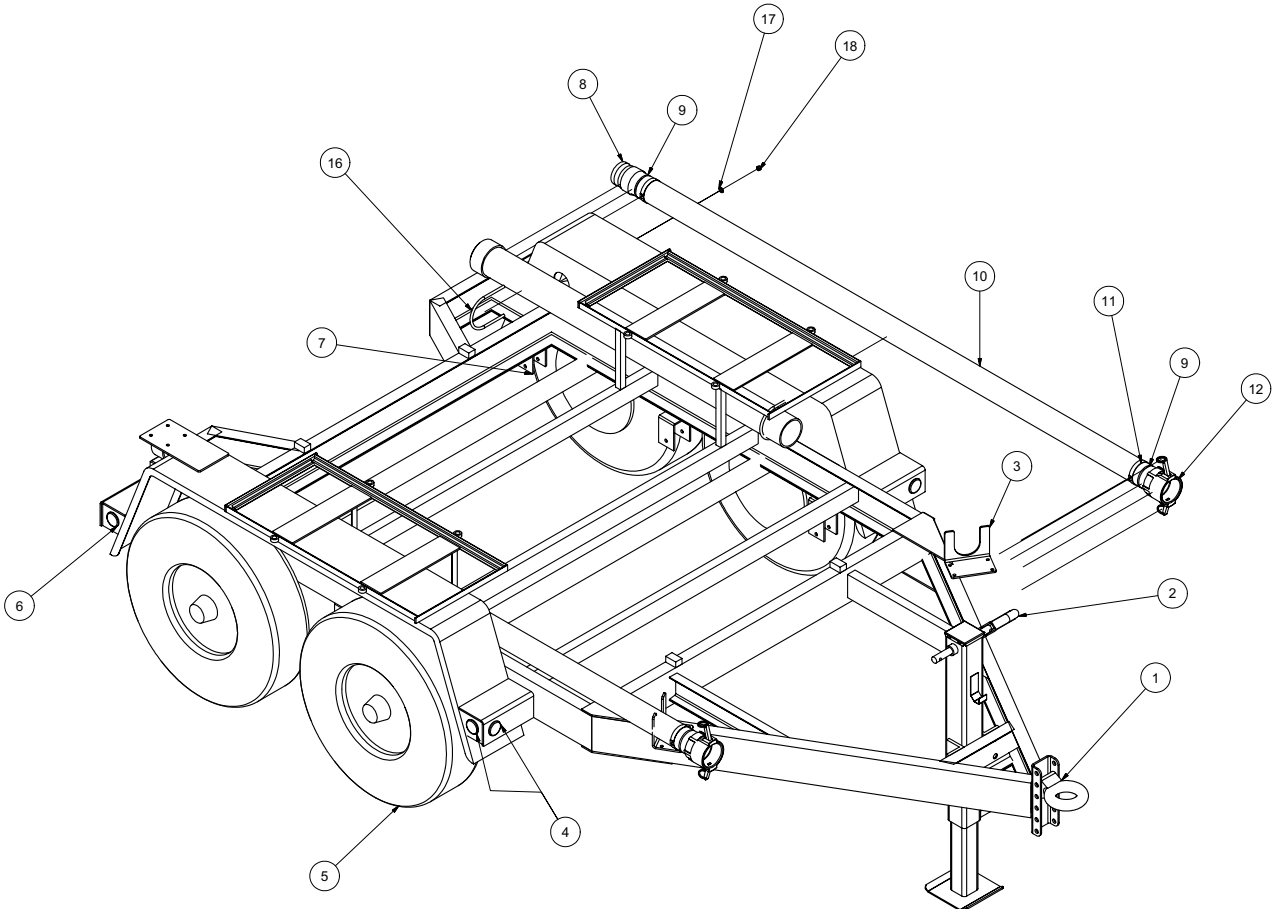

# Trailer Assy 250

ITEM	QTY	PART #	DESCRIPTION
1	1	8043980	PINTLE EYE
2	1	8043548	JACK-MANUAL
	1	8043984	JACK HANDLE
3	2	8040940	HOSE STORAGE BRACKET
	4	U100060	NUT, HEX 3/8"
	4	U200600	WASHER, FLAT 3/8"
	4	U210060	WASHER, LOCK 3/8"
4	4	8044000	2" YELLOW MARKER LIGHT
	4	8044002	2" RUBBER GROMMET
5	4	8045671	TIRE, ST205 X 75 D15
	4	8045672	WHEEL, R15X 6
	2	8045673	AXLE
	4	8045674	HUB
	20	8043987	LUG HUT
	4	8043988	GREASE CAP
	4	8043989	GREASE CAP PLUG
6	4	8043999	2" RED MARKER LIGHT
	4	8044002	2" RUBBER GROMMET
7	4	8045675	SPRING
	8	8045677	U-BOLT
	8	8045676	U-BOLT NUT
	4	8045678	TIE PLATE
8	2	8030391	BANJO 3" MALE 3" FNPT
9	4	8030287	3" HOSE X 3" MNPT ADAPTER
10	2	8042311	HOSE VAC KANAFLEX 3-100LG
11	4	8030356	PUNCHLOCK 16-5
12	2	8030392	3" FEMALE COUPLER
13	2	8044001	4" STOP/TURN LIGHT
	2	8044003	4" RUBBER GROMMET
14	1	8045679	LH BRAKE ASSEMBLY
	2	8045680	MAGNET KIT
	2	8045681	SHOE KIT
	1	8045682	ADJUSTER KIT
15	1	8045683	RH BRAKE ASSEMBLY
	2	8045680	MAGNET KIT
	2	8045681	SHOE KIT
	1	8045681	ADJUSTER KIT
16	4	U800130	U-BOLT 3/8" X 4.5 WIDE
17	8	U200600	WASHER, FLAT 3/8"
18	8	U100060	NUT, HEX 3/8" - 16

# Skid Assembly

# V250

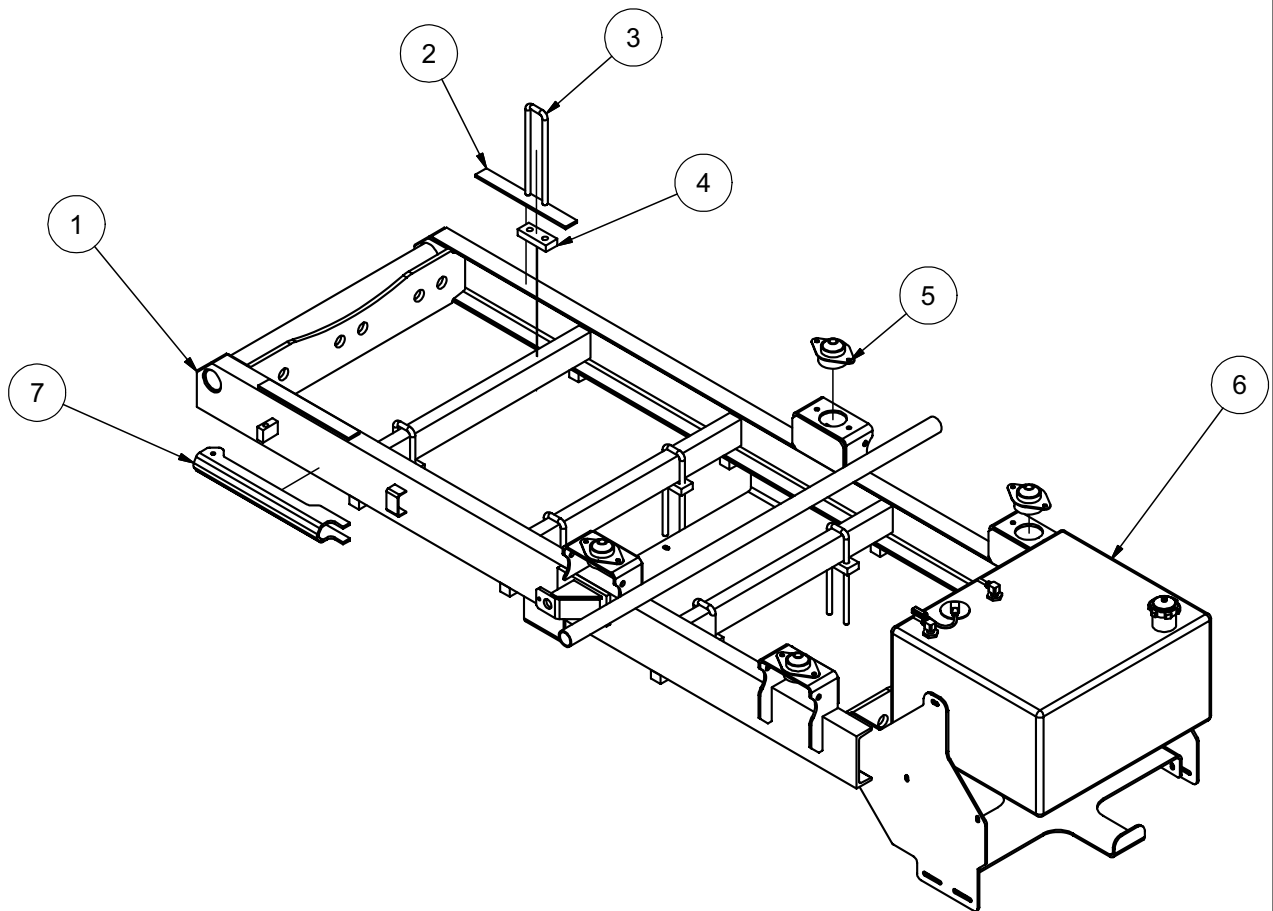

# Skid Assembly

# V250

ITEM	QTY	PART #	DESCRIPTION
1	1	8040738	250 SKID - WELDMENT
2	2	8041263	STRIP, PLASTIC
	4	U030015	SCREW SOCKET FLAT HEAD 1/4" -20 X 3/4"
3	6	8040038	U-BOLT, 1/2-13 X 10"LG - 1 5/8" GAP. GR8
4	6	8040240	U-BOLT MOUNTING BLOCK
5	4	8030904	ISOLATOR 840LB
	4	U000560	SCREW, HC 3/8"-16 X 3"
	4	8030389	WASHER, SNUBBLING
	4	U120110	NUT, LOCK 3/8"-16
	8	U000420	SCREW, HC 3/8"-16 X 1"
	24	U200060	WASHER, FLAT 3/8"
	8	U210060	WASHER, LOCK 3/8"
	8	U100060	NUT, HEX 3/8"-16
6	1	8042380	FUEL TANK (22GAL)
	1	8043359	STRAP W/ EYEBOLT
	1	8042380-1	FUEL TANK CAP
	1	8041725	FUEL SENDING UNIT
	1	8041725-1	SEND UNIT GASKET
	1	8045686	HOSE VAC FUEL 5/16 - 30
	4	U800015	CLAMP, HOSE 4 - 5/8
	1	8040965	HOSE VAC FUEL 5/16 - 58
7	1	8042778	TANK SAFETY BRACE (250)

# Tool Rack Assembly

**STD**

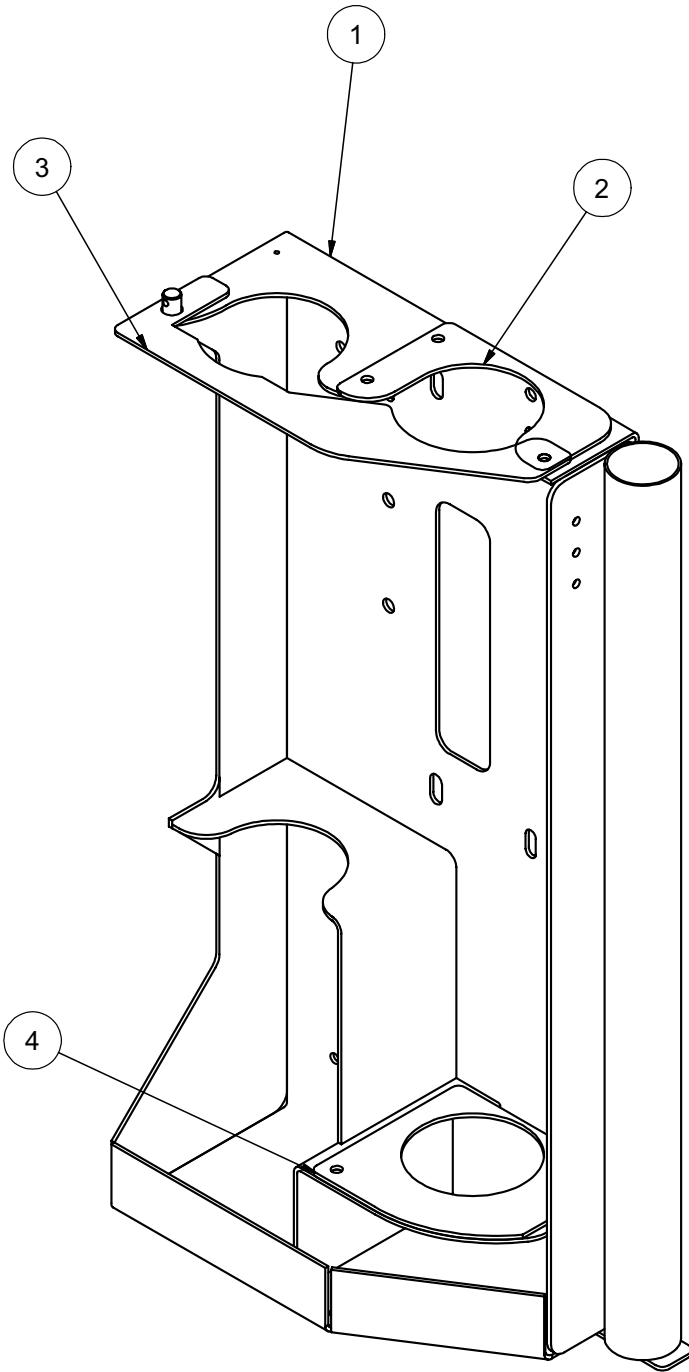

## I-BEAM TRAILER

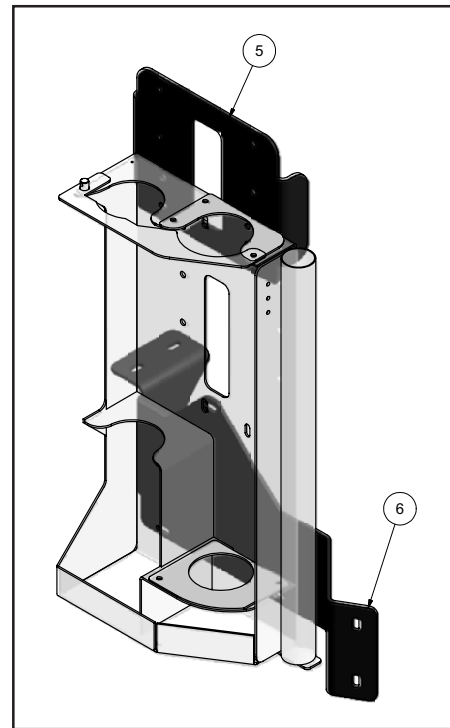

## SKID UNIT

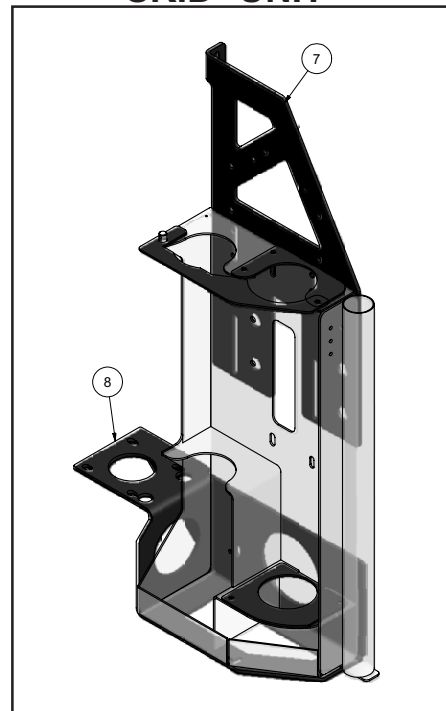

090909-E

**VACASSY757**

# Tool Rack Assembly

# STD

ITEM	QTY	PART NO.	DESCRIPTION
1	1	8040985	TOOL RACK WELDMENT
2	1	8045610	TOOL RACK 3" TOP INSERT
3	1	8040884	TOOL RACK CLOSURE
	1	R700175	R CLIP 7/8"
	1	8041259	STRAP, 10"
	1	8041485	LANYARD CABLE
	1	8041244	CLEVIS PIN 1/2" DIA. 3/4"
4	1	8045609	TOOL RACK BOTTOM INSERT
5	1	8044818	ANTIFREEZE BRACKET (I-BEAM TRAILER)
	4	U000020	SCREW, HC 5/16"-18 X 1.00"
	4	U000180	SCREW, HC 5/16"-18 X .750"
	16	U200040	WASHER, FLAT 5/16"
	8	U210041	NUT, LOCK NY 5/16"
6	1	8044817	TOOL RACK BRACKET (I-BEAM TRAILER)
	3	U000420	SCREW, HC .375"-16 X 1.00"
	3	U120110	NUT, LOCK .375"-16
	6	U200600	WASHER, FLAT .375"
7	1	8041780	ENCLOSURE STIFFENER BRACE (SKID UNITS)
	4	U000040	SCREW, HC 1/4"-20 X .750"
	8	U200020	WASHER, FLAT .250"
	4	U120100	NUT, LOCK .250"
8	1	8043601	TOOL RACK BRACKET (SKID UNITS)
	4	U000420	SCREW, HC .375"-16 X 1.00"
	8	U200060	WASHER, FLAT .375"
	4	U120110	NUT, LOCK .375-16
	2	U000040	SCREW, HC 1/4"-20 X .750"
	4	U200020	WASHER, FLAT .250"
	2	U120100	NUT, LOCK .250"

# Tools

# 3" Suction Tool

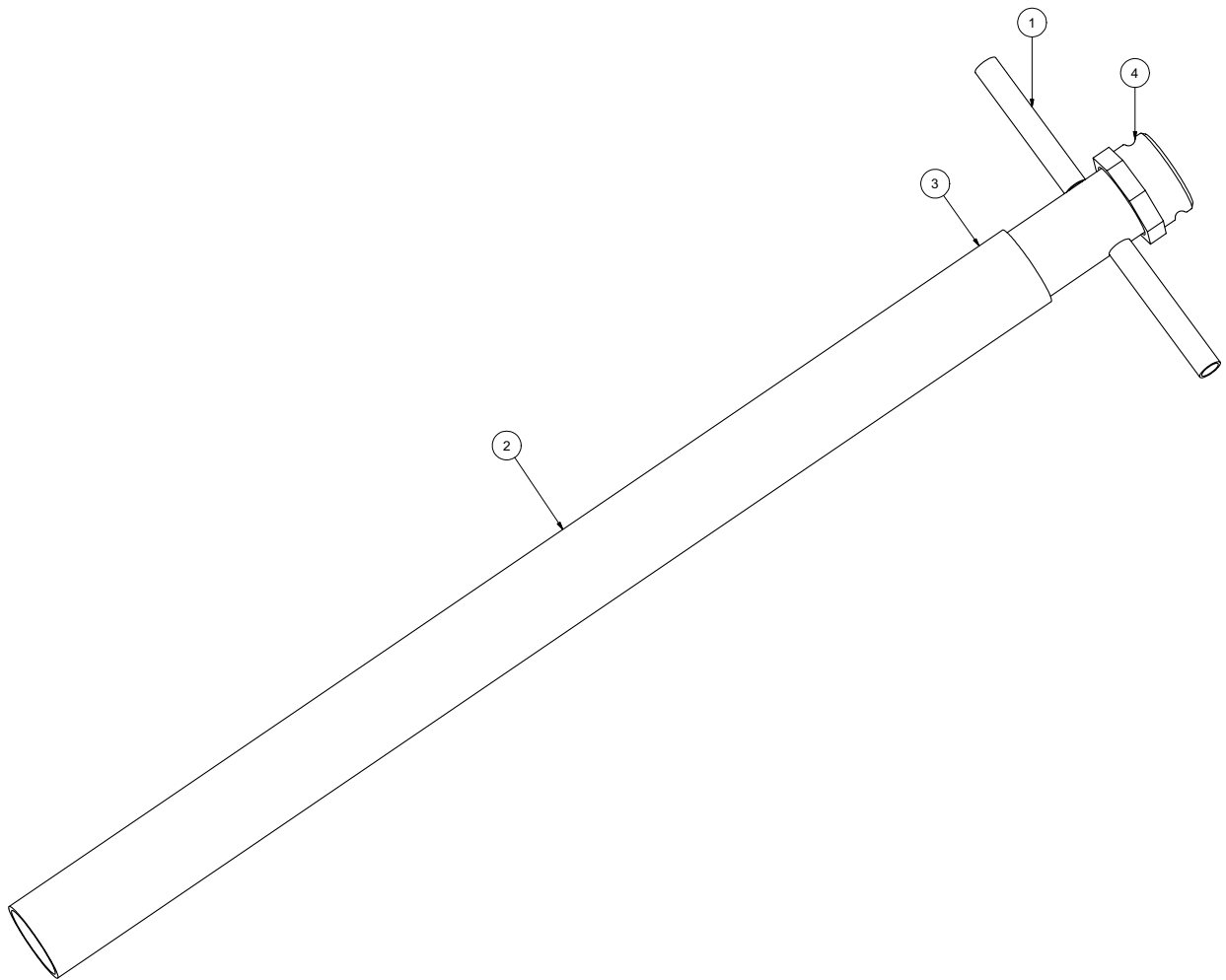

072308

VACASSY712



# Tools

# 3" Suction Tool

ITEM	QTY	NUMBER	DESCRIPTION
	1	8030215	TOOL VAC SUCTION 3" COMPLETE
1	1	8030317	TOOL VAC HANDLE ASSEMBLY 3"
2	1	8030412	PVC VACUUM TUBE 3"
3	1	8030244	CLAMP, 3.5" PUNCHLOK
4	1	8030391	COUPLING, 3" BANJO

# Tools (Option)

# Reduction Tool STD

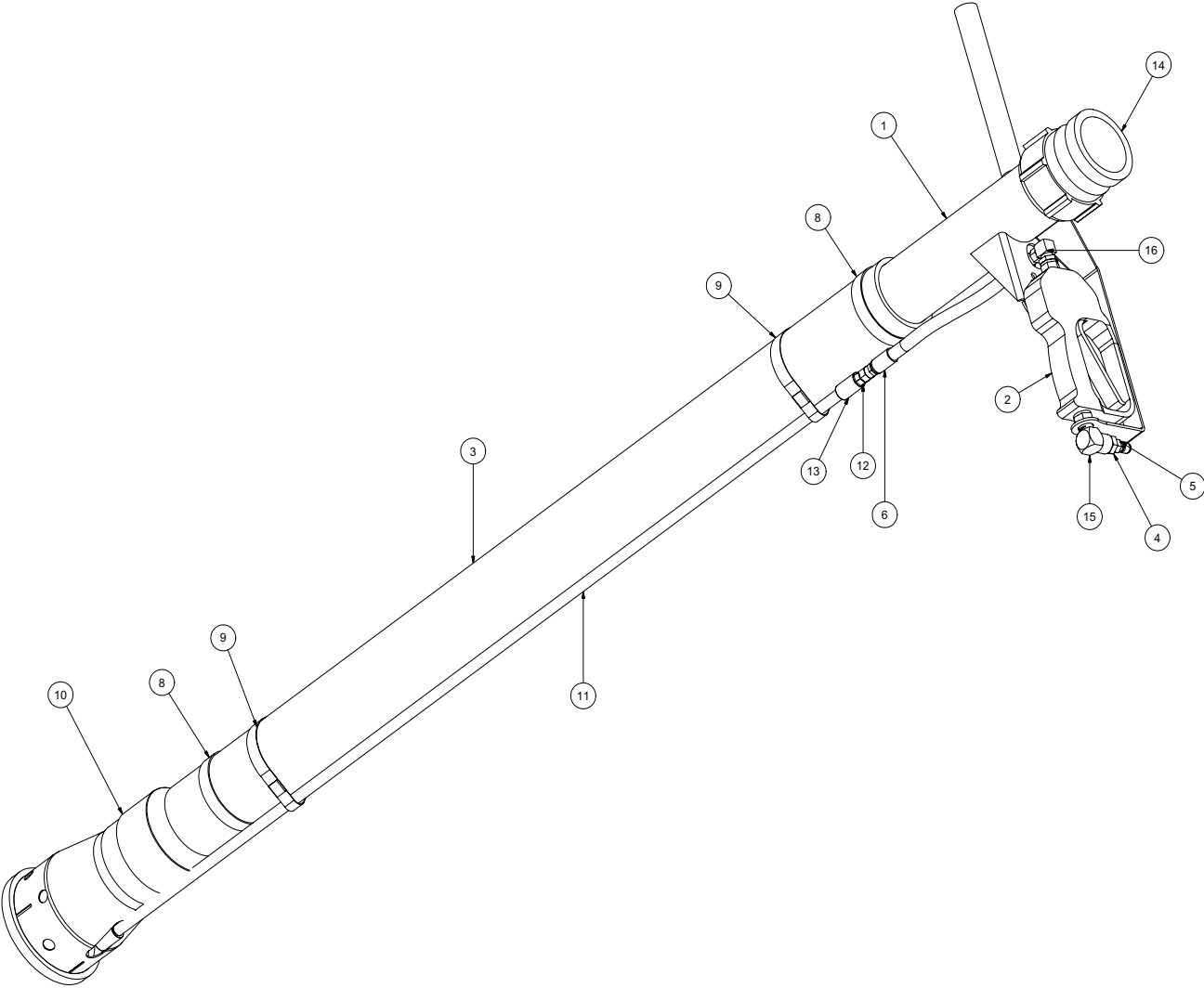

# Tools(Optional)

# Reduction Tool STD

ITEM	QTY	PART NO.	DESCRIPTION
-	-	8043115	TOOL VAC REDUCTION STD COMPLETE
1	1	8042862	TOOL VAC HEAD ASSY 3"
2	1	8042026	STRAIGHT SPRAY GUN
3	1	8042811	TOOL VAC REDUCTION PVC 3" X 48"
4	1	T400023	UNION 6MP 4FP
5	1	8030486	WATER QD 1/4 MNPT SS
6	2	T320030	FITTING, HOSE 4HO 4FJ
7	1	8031278	HOSE ASSEMBLY REDUCTION TOOL
8	2	8042605	CLAMP HOSE T BOLT 350
9	2	8042855	CLAMP HOSE T BOLT 375
10	1	8030627	TOOL VAC REDUCTION LOWER ASSY
11	1	8043764	VAC WATER SUPPLY TUBE CHROME 1/4NPT
12	1	T400020	UNION 1/4" MP-1/4" MJ STRAIGHT
13	1	8030367	VAC FITT 1/4" FF-S
14	1	8030391	BANJO 3" MALE 3" FNPT
15	1	T401065	ELBOW, 3/8 MP - 3/8 FP
16	1	T401100	ELBOW 4MP 4MJ 90
*	2	8030370	REDUCTION TOOL NOZZLE
*	2	8031268	REDUCTION TOOL NOZZLE 45 DEG

\* NOT SHOWN

# Tools

# Wash Wand

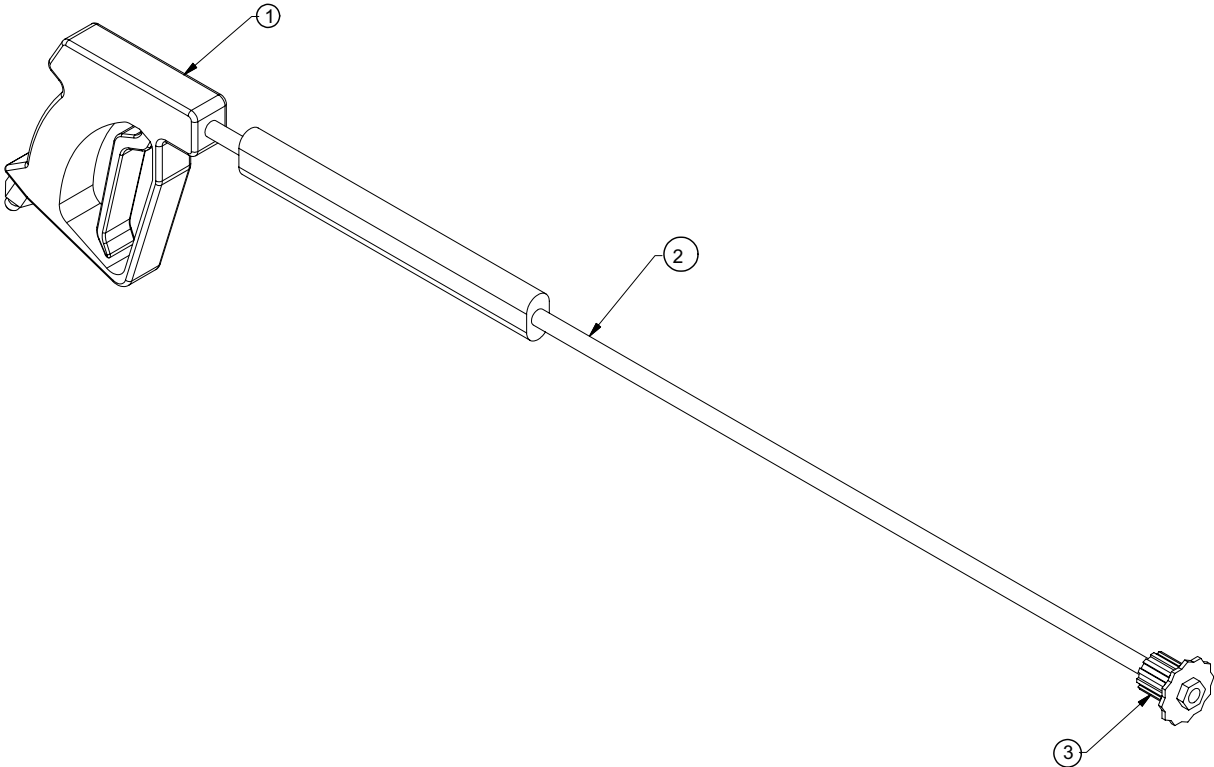

# Tools

# Wash Wand

Item	Qty	Number	Description
	1	8030348	TOOL VAC SPRAY WAND COMPLETE
1	1	8030928	TRIGGER ASSEMBLY
2	1	8030847	WAND
3	1	8031308	NOZZLE,#6 40 DEGREE FOR WAND

# Tools

# Lawn Sweeper 3''

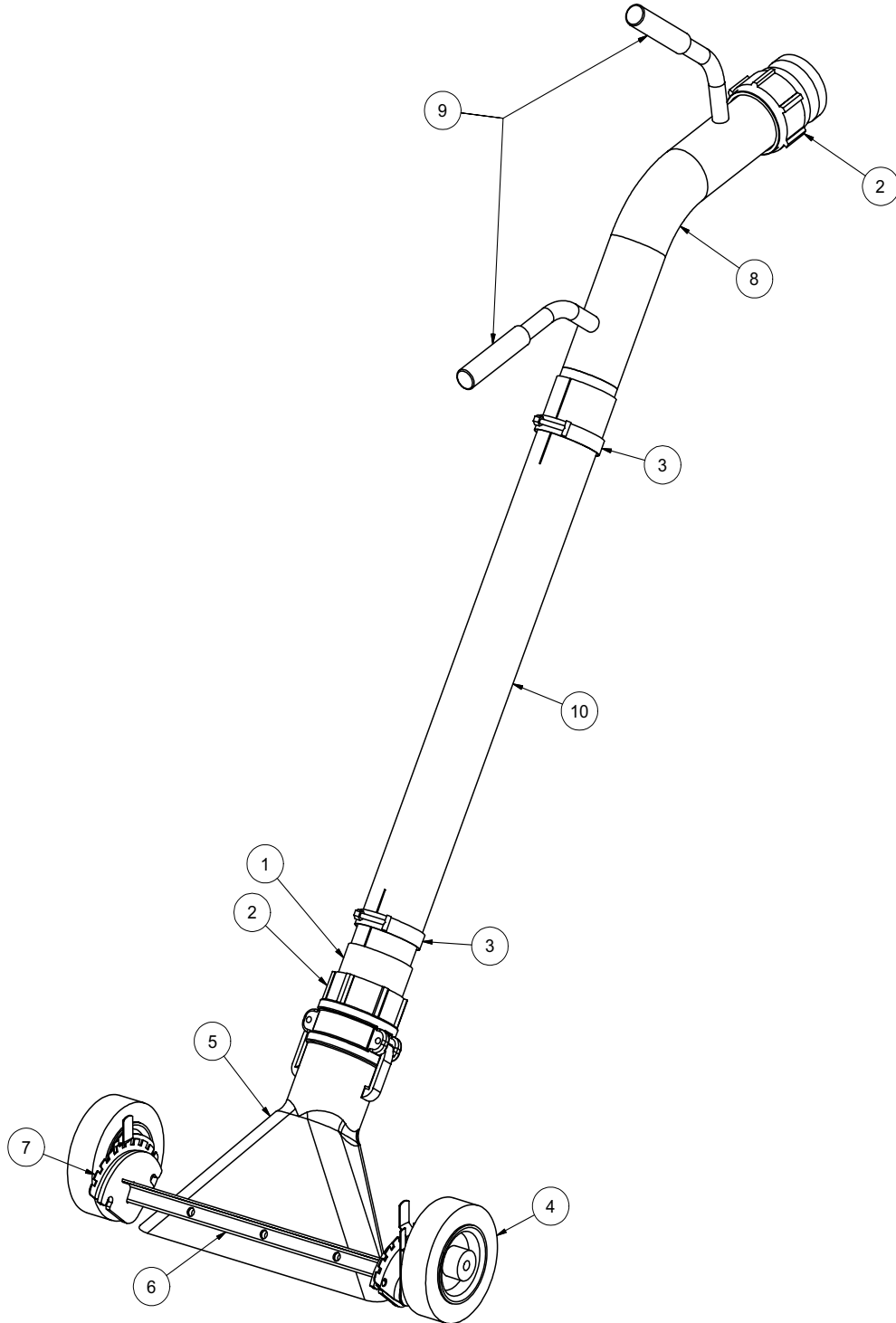

071708

VACASSY713

# Tools

# Lawn Sweeper 3''

ITEM	QTY	PART #	DESCRIPTION
1	1	8030287	3" HOSE X 3" MNPT ADAPTER
2	2	8030391	BANJO 3" MALE 3" FNPT
3	2	8042605	CLAMP T-BOLT 3" (350)
4	2	8043887	WHEEL 6" PNEUMATIC
5	1	8043925	DUCKBILL 3" ALUMINUM
6	1	8043928	LS WHEEL WELDMENT
7	1	8043931	WHEEL ADJUSTERS (1 LEFT/1 RIGHT)
8	1	8043933	LS HANDLE WELDMENT
9	2	J300080	HANDLE GRIP
10	1	8043932	PVC 3" X 30"

# Valve Box Cleanout Tool

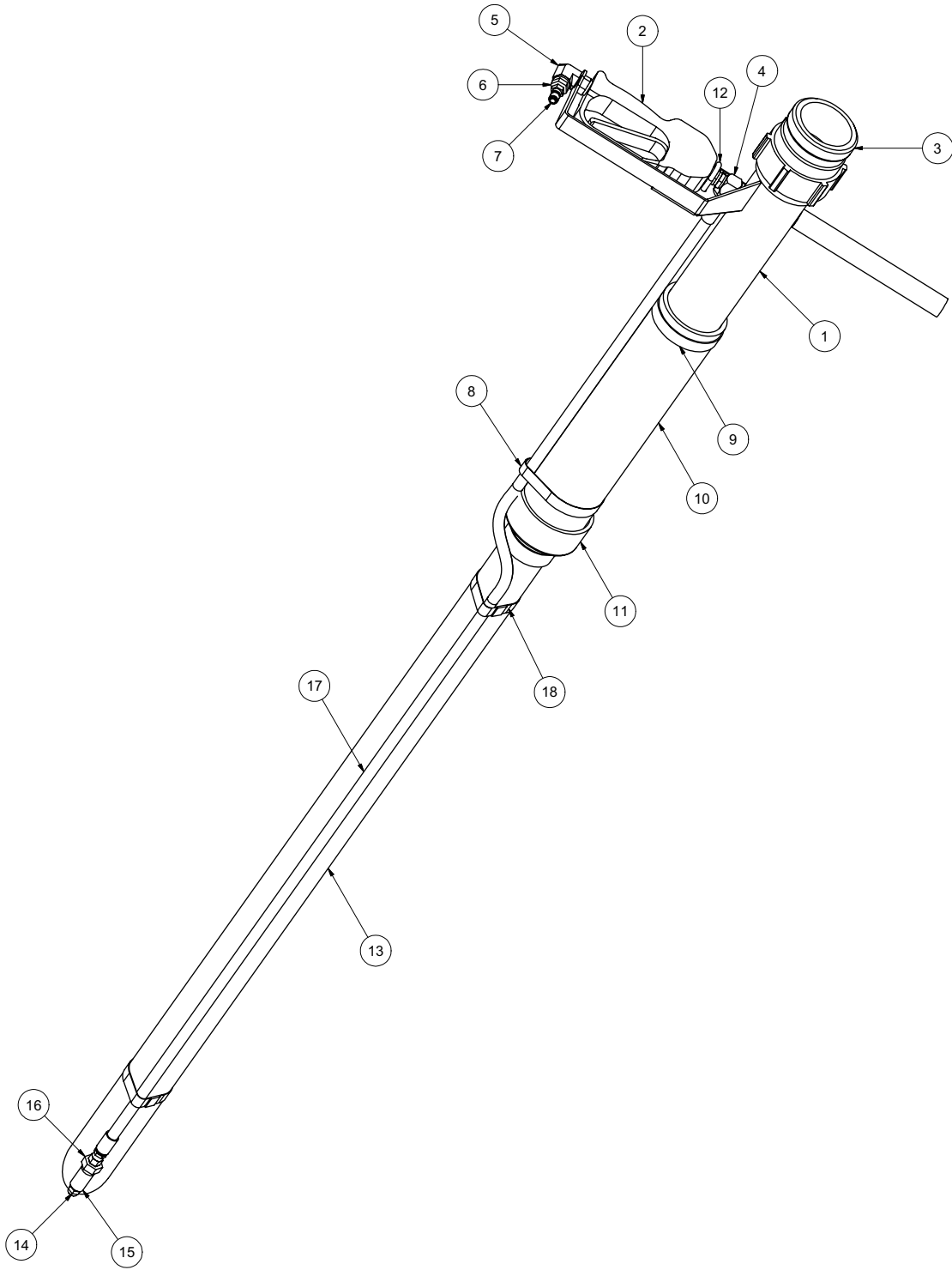

050709

VACASSY714



# Valve Box Cleanout Tool

ITEM	QTY	PART NO.	DESCRIPTION
1	1	8042862	REDUCTION TOOL HEAD WELDT
2	1	8042026	STRAIGHT SPRAY GUN
3	1	8030391	BANJO 3" MALE FNPT
4	1	T401100	ELBOW 4MP 4MJ 90
5	1	T401065	ELBOW, 3/8 MP - 3/8 FP
6	1	T400023	REDUCER 6MP 4FP
7	1	8030486	WATER QD 1/4 MNPT SS
8	1	8042855	CLAMP HOSE T-BOLT 375
9	1	8042605	CLAMP HOSE T-BOLT 350
10	1	8044096	PVC 3" DIA X 9" LONG
11	1	8030669	REDUCER PVC 3" TO 2" SLIP ON
12	1	U010019	U-BOLT 1_4-20 X 3_4 WIDE X 2 1_4 LONG
13	1	8044097	PVC 2" DIA X 42.5" LG
14	1	8031246	NOZZLE, .100 X 0 DEG
15	1	T422010	COUPLING 1/4"FP
16	1	U400020	UNION, 1/4" MP - 1/4" MJ
17	1	8044098	HOSE ASSY VALVE BOX CLEANOUT TOOL
18	2	8045316	CLAMP, HOSE T-BOLT 275

# Surface Cleaner

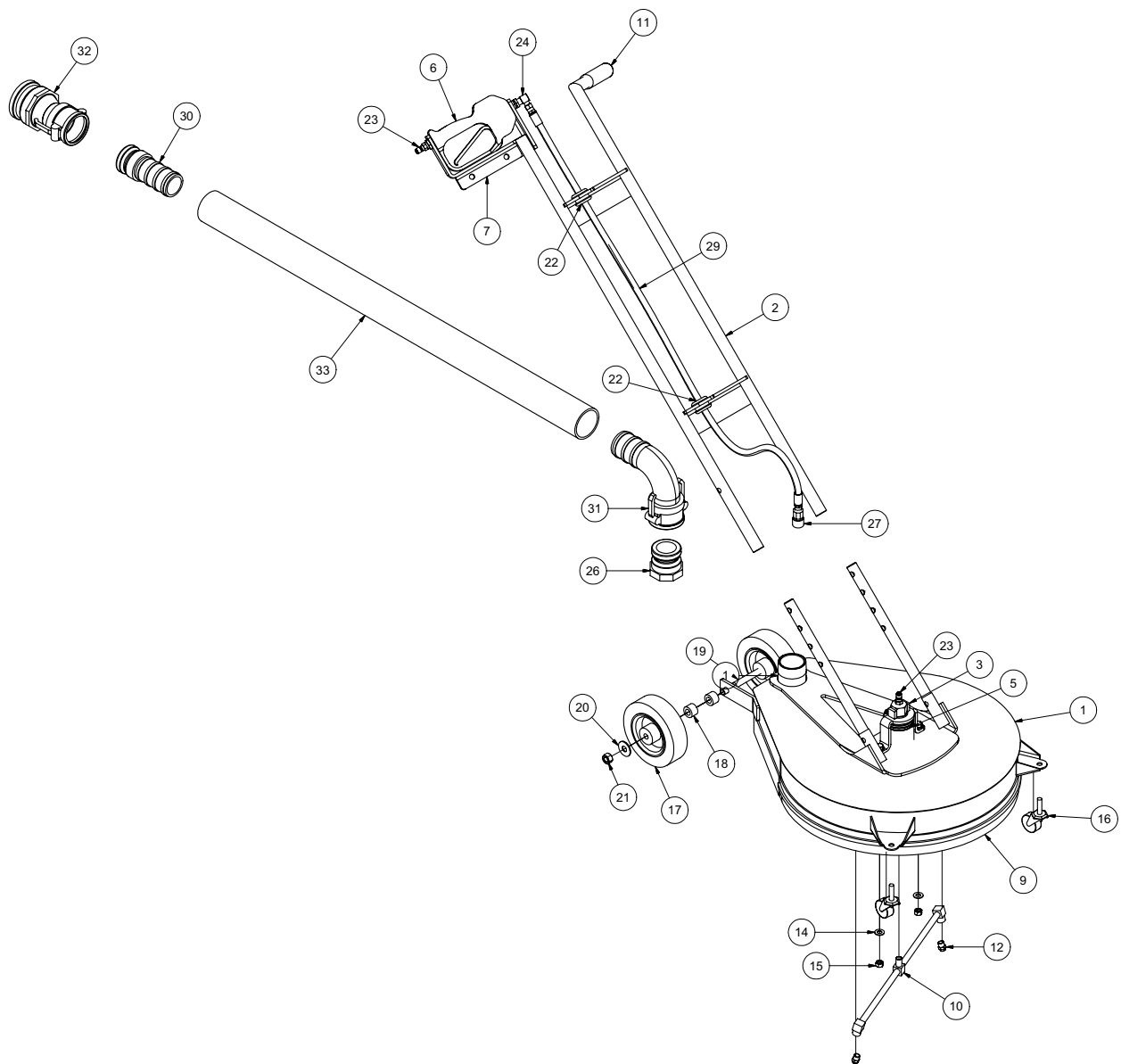

# Surface Cleaner

ITEM	QTY	PART NO.	DESCRIPTION
1	1	8041887	SURFACE CLEANER - HEAD ASSY
2	1	8042019	HANDLE ASSY
3	1	8041890	ROTARY RETAINER
4	2	8042022	HANDLE ADJ. TUBE
5	1	8044102	ROTARY HEAD
6	1	8042026	STRAIGHT SPRAY GUN
7	1	8042020	GUN CAPTURE BRACKET
8	1	8044103	SQUEEGEE
9	1	8044104	FLEXIBLE BRUSH
10	1	8044105	ROTARY ARM
11	1	8044106	GRIP HANDLE
12	2	8031419	NOZZLE, #4.0 25 DEG
13	2	U000420	SCREW, HC 3/8-16 X 1.00
14	4	U200600	WASHER, FLAT 3/8"
15	2	U100060	NUT, HEX 3/8-16
16	2	8044107	SWIVEL CASTER 1 5/8"
17	2	8043887	WHEEL 6" PNEUMATIC
18	2	8043591	SURFACE CLEANER REAR WHEEL SPACER
19	1	U001060	SCREW, HC 1/2-13 X 6.0
20	2	U200100	WASHER, FLAT 1/2"
21	1	U120120	NUT, LOCK 1/2-13
22	2	8041686	GROMMET 1"ID- 1 1/4"DOG-1/4"WO
23	2	8030486	WATER QD 1/4 MNPT SS
24	1	T401100	ELBOW 4MP 4MJ 90
25	1	T320030	FITTING, HOSE 4HO 4FJ
26	1	8043389	ADAPTER M2" F THREAD
27	1	8030526	FITTING, QD WATER 1/4"F-1/4"FP
28	1	T320300	FITTING, HOSE 4HO 4MP
29	1	8044108	HOSE VAC SURFACE CLEANER
30	1	8043392	ADAPTER M2" F THREAD
31	1	8043391	REDUCER COUPLER 2"F 90 DEG - 3"M
32	1	8043395	REDUCER COUPLER 2" X 3" ADAPTER
33	1	8043398	HOSE VAC CLEAR 2"
*	2	8043397	CLAMP VAC CLEAR HOSE 2"
*	4	U360020	PIN, U-LOCK 3/8 X 1.5

# Tools

# Rotary Lance

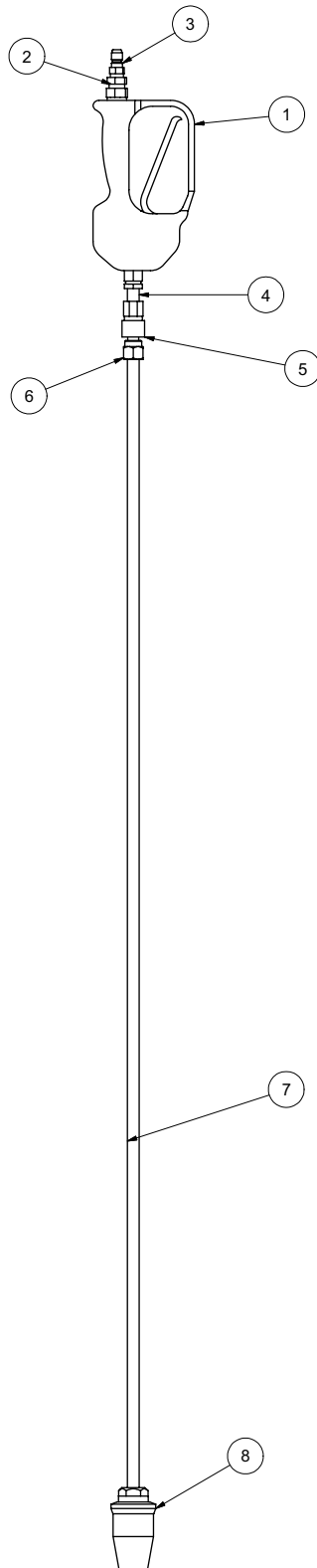

042409

VACASSY716

# Tools

# Rotary Lance

ITEM	QTY	PART NO.	DESCRIPTION
1	1	8042026	STRAIGHT SPRAY GUN
2	1	T400023	UNION 6MP-4FP
3	1	8030486	WATER QD 1/4MNPT SS
4	1	T421010	NIPPLE, CLOSE 1/4"
5	1	8030526	FITTING, QD WATER 1/4F - 1/4"FP
6	1	8030487	WATER QD 1/4 FNPT SS
7	1	8043764	47 INCH LANCE EXT. 1/4NPT X 1/4NPT
8	1	8042691	ROTARY WOBBLE NOZZLE 90

# Vacuum Diesel Engine Schematic

## VACUUM DIESEL ENGINE SCHEMATIC

080108

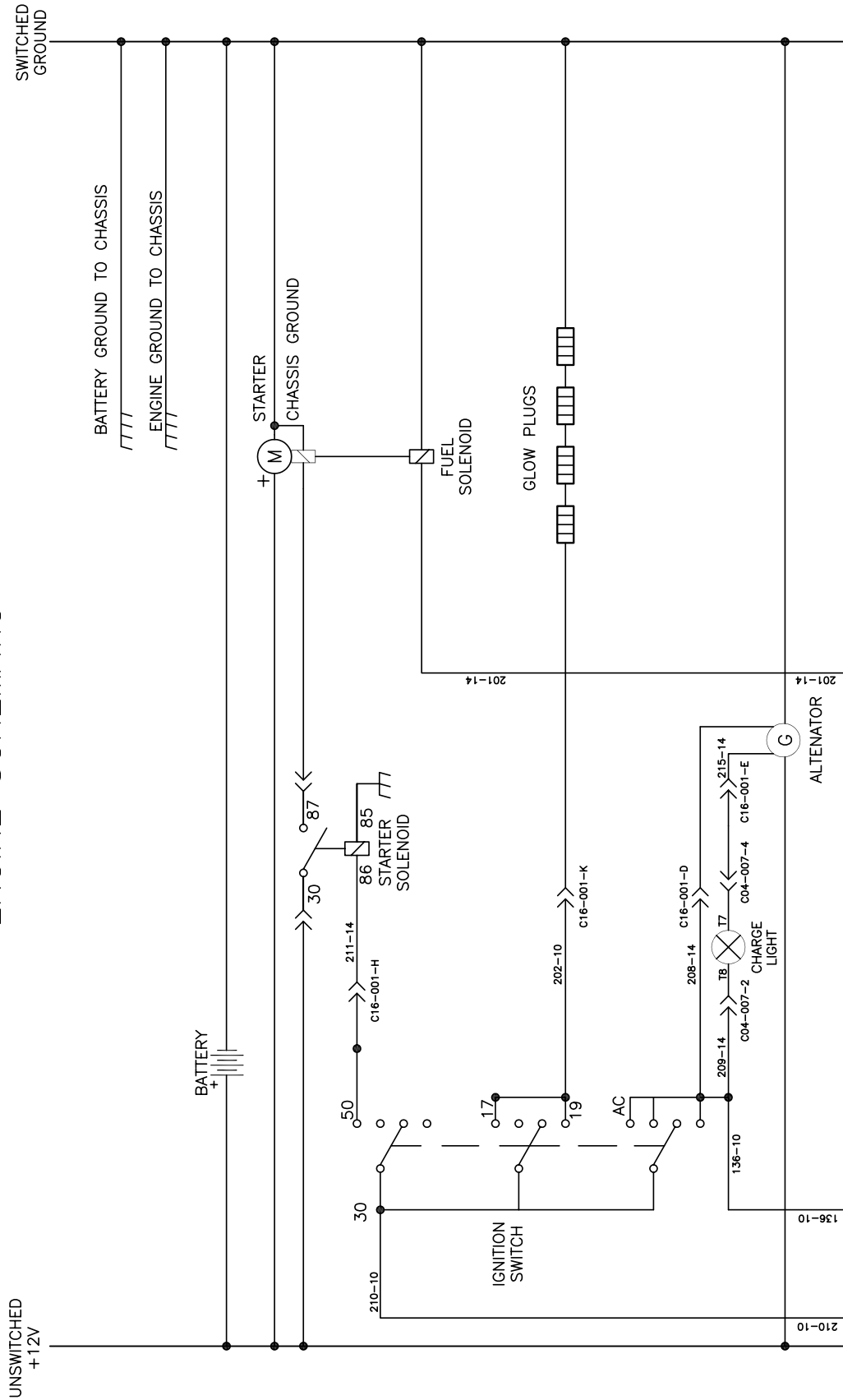

# Vacuum Diesel Engine Schematic

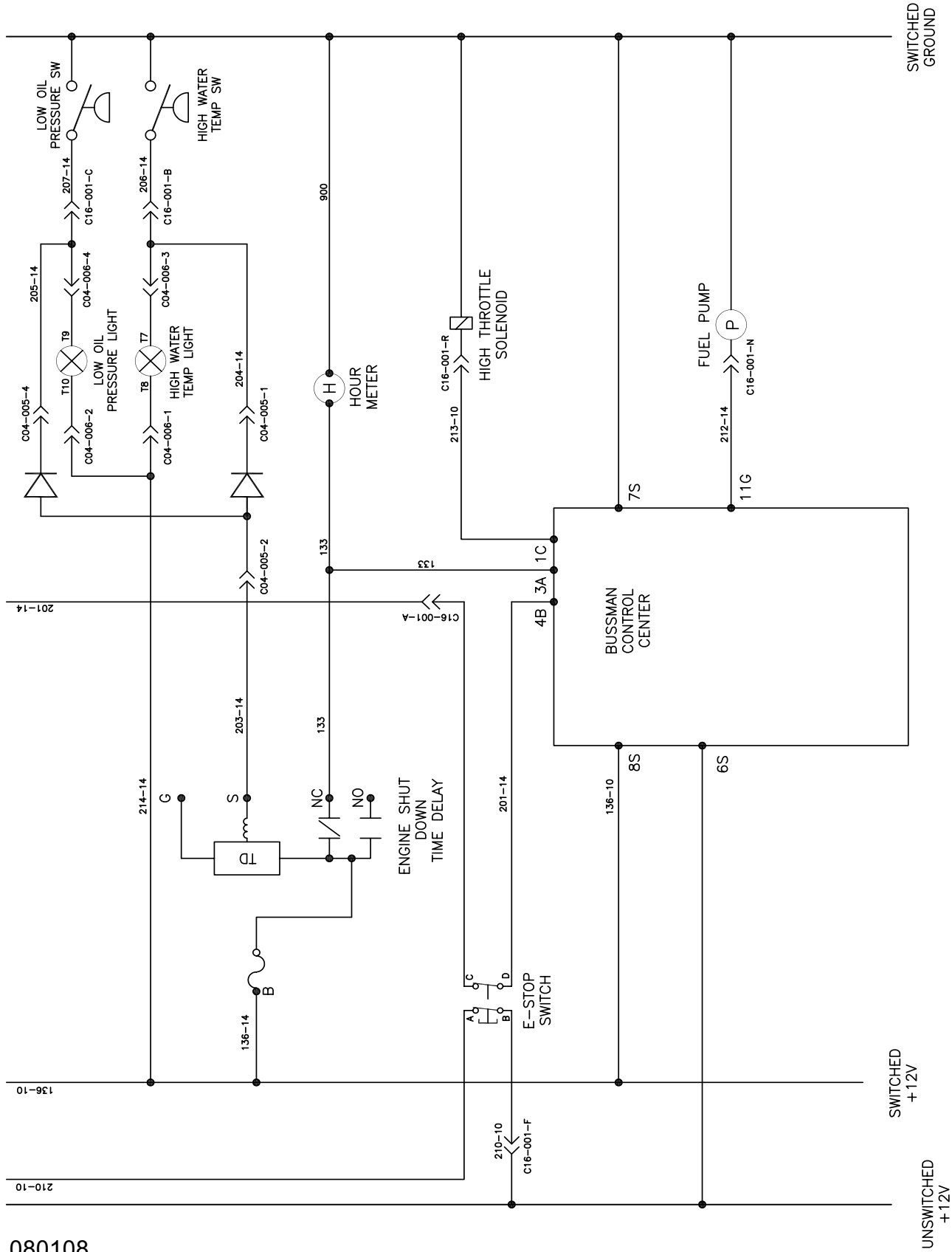

080108

# Vacuum Diesel Engine Schematic

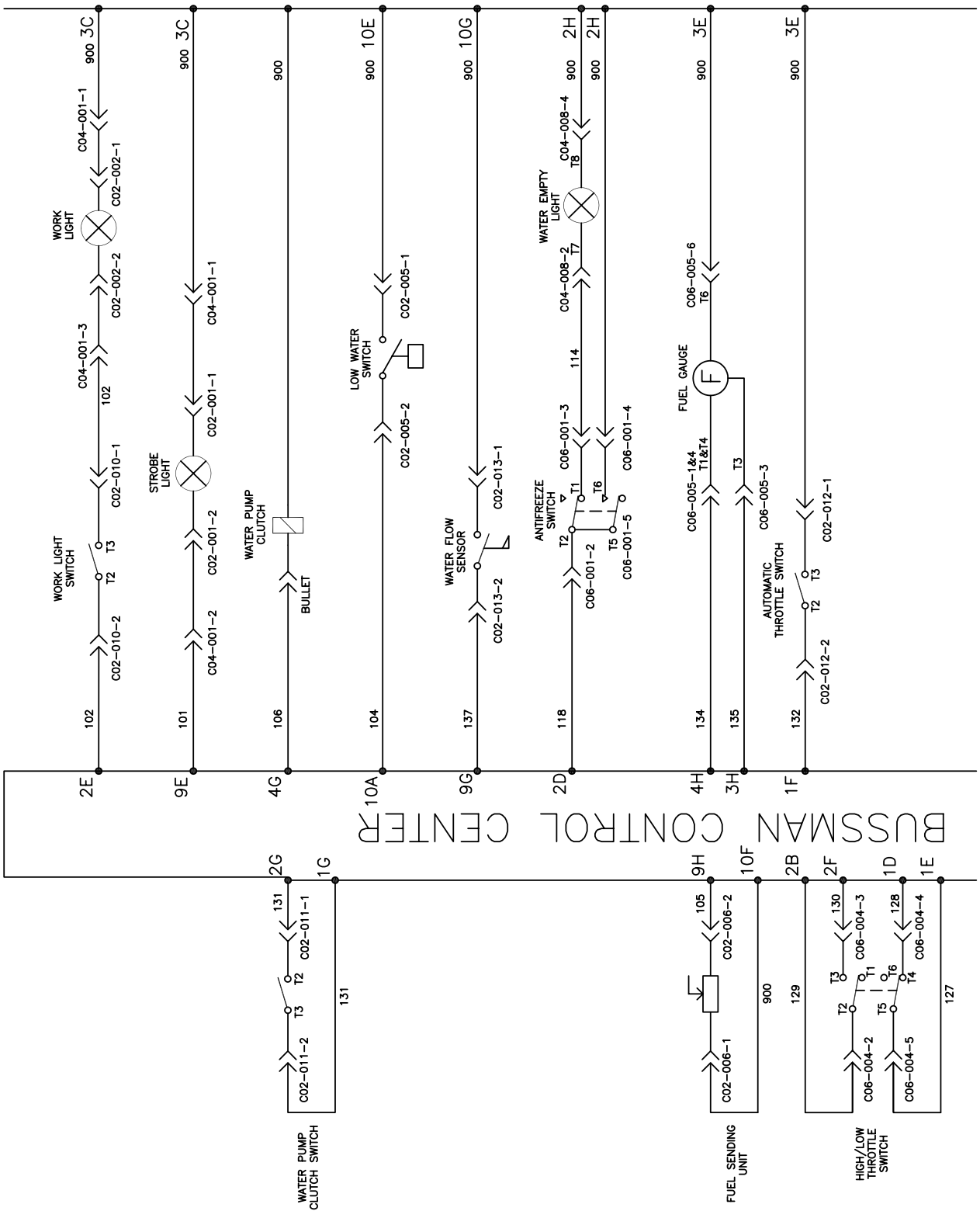



# Vacuum Diesel Engine Schematic

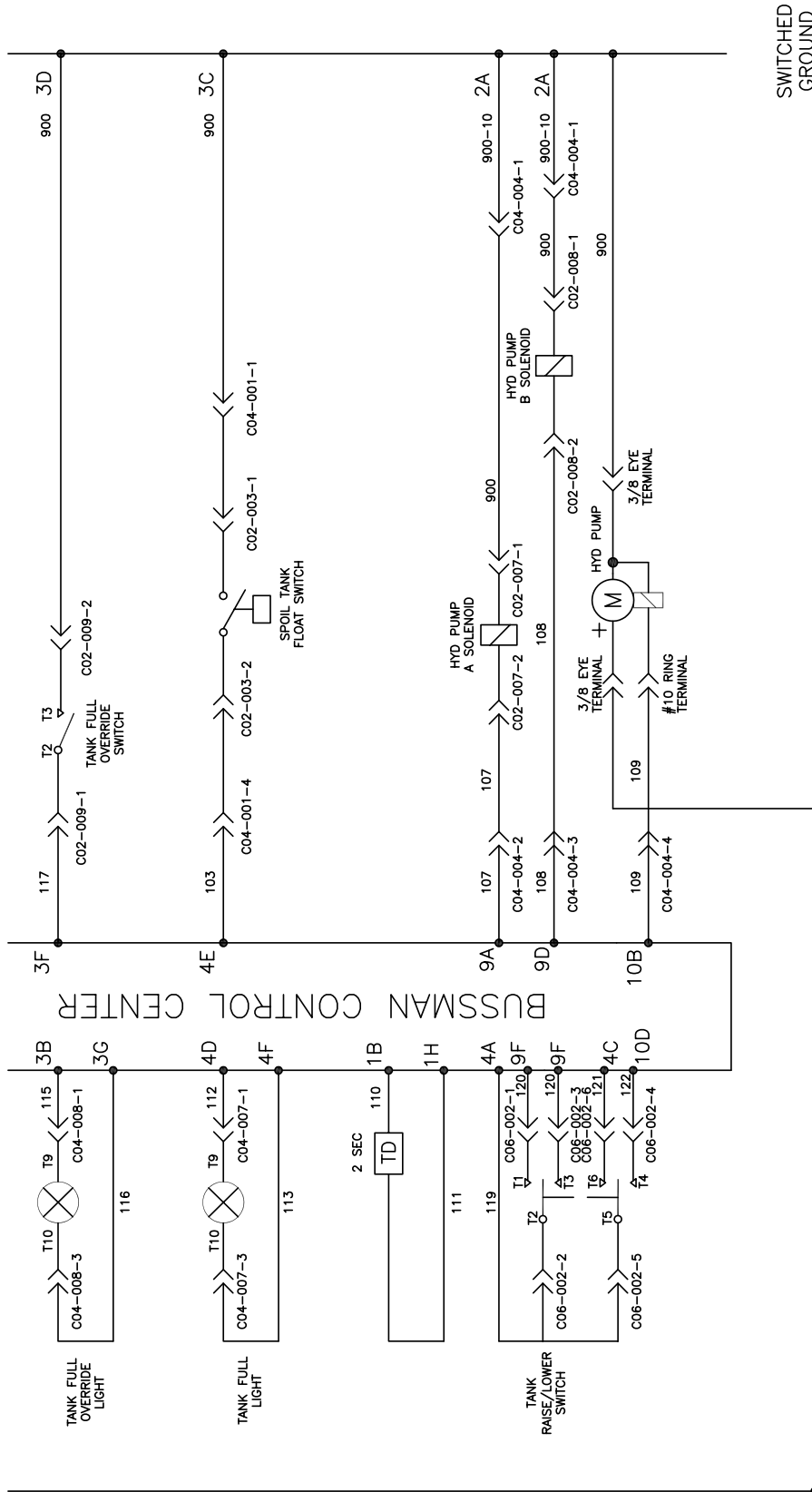

# Vacuum Diesel Engine Schematic

## BUSSMAN CONTROL CENTER OPTIONS

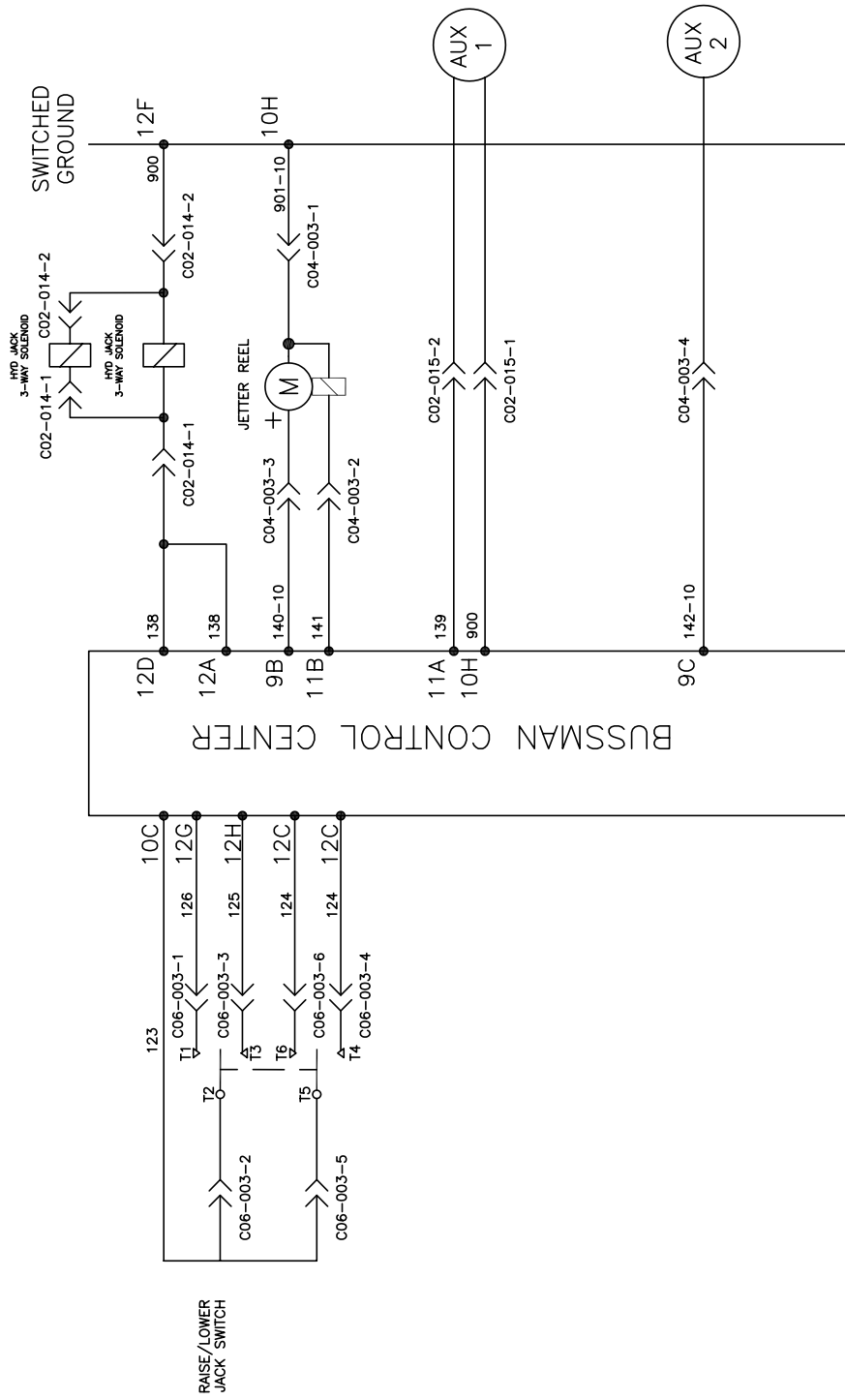

**PAGE LEFT BLANK**

# ROOTS

*Blowers Compressors Exhausters*

## Universal URAI-DSL

### Contents

Information Summary.....	1	Troubleshooting & Maintenance.....	10
Safety Precautions.....	3	Inspection & Maintenance.....	11-13
Operating Limitations.....	3	Data Tables.....	14-15
Lubrication Installation.....	4-6	Assembly Drawings.....	16
Operation Lubrication.....	7	Parts List.....	17
Operation.....	8	Basic Connection & Drive Shaft Information.....	18
Troubleshooting.....	9		

### Do These Things To Get The Most From Your ROOTS™ blower

- **Make sure both driving and driven equipment is correctly lubricated before start-up. See LUBRICATION.**
- In event of trouble during installation or operation, do not attempt repairs of ROOTS furnished equipment. Notify ROOTS, giving all nameplate information plus an outline of operating conditions and a description of the trouble. Unauthorized attempts at equipment repair may void ROOTS warranty.
- Units out of warranty may be repaired or adjusted by the owner. Good inspection and maintenance practices should reduce the needs for repairs.

**NOTE:** Information in this manual is correct as of the date of publication. ROOTS reserves the right to make design or material changes without notice, and without obligation to make similar changes without notice, and without obligation to make similar changes on equipment of prior manufacture.



**Roots**

## Safety Precautions

It is important that all personnel observe safety precautions to minimize the chances of injury. Among many considerations, the following should be particularly noted:

- Blower casing and associated piping or accessories may become hot enough to cause major skin burns on contact.
- Internal and external rotating parts of the blower and driving equipment can produce serious physical injuries. Do not reach into any opening in the blower while it is operating, or while subject to accidental starting. Protect external moving parts with adequate guards.
- Disconnect power before doing any work, and avoid bypassing or rendering inoperative any safety or protective devices.
- If blower is operated with piping disconnected, place a strong coarse screen over the inlet and avoid standing in the discharge air stream. **CAUTION: Never cover the blower inlet with your hand or other part of body.**
- Stay clear of the blast from pressure relief valves and the suction area of vacuum relief valves.
- Use proper care and good procedures in handling, lifting, installing, operating and maintaining the equipment.
- Casing pressure must not exceed 25 PSI (1725 mbar) gauge. Do not pressurize vented cavities from an external source, nor restrict the vents without first consulting Roots.
- Do not use air blowers on explosive or hazardous gases.
- Other potential hazards to safety may also be associated with operation of this equipment. All personnel working in or passing through the area should be trained to exercise adequate general safety precautions.

## Operating Limitations

A ROOTS blower or exhauster must be operated within certain approved limiting conditions to enable continued satisfactory performance. Warranty is contingent on such operation.

Maximum limits for pressure, temperature and speed are specified in TABLE 1 for various models & sizes of blowers & exhausters. These limits apply to all units of normal construction, when operated under standard atmospheric conditions. Be sure to arrange connections or taps for instruments, thermometers and pressure or vacuum gauges at or near the inlet and discharge connections of the unit. These, along with a tachometer, will enable periodic checks of operating conditions.

**PRESSURE** – The pressure rise, between inlet and discharge, must not exceed the figure listed for the specific unit frame size concerned. Also, in any system where the unit inlet is at a positive pressure above atmosphere a maximum case rating of 25 PSI gauge (1725 mbar) should not be exceeded without first consulting Roots. Never should the maximum allowable differential pressure be exceeded.

On vacuum service, with the discharge to atmospheric pressure, the inlet suction or vacuum must not be greater than values listed for the specific frame size.

**TEMPERATURE** – Blower & exhauster frame sizes are approved only for installations where the following temperature limitations can be maintained in service:

- Measured temperature rise must not exceed listed values when the inlet is at ambient temperature. Ambient is considered as the general temperature of the space around the unit. This is not outdoor temperature unless the unit is installed outdoors.
- If inlet temperature is higher than ambient, the listed allowable temperature rise values must be reduced by 2/3 of the difference between the actual measured inlet temperature and the ambient temperature.
- The average of the inlet and discharge temperature must not exceed 250°F. (121°C).
- The ambient temperature of the space the blower/motor is installed in should not be higher than 120°F (48.8°C).

**SPEED** – These blowers & exhausters may be operated at speeds up to the maximum listed for the various frame sizes. They may be direct coupled to suitable constant speed drivers if pressure/temperature conditions are also within limits. At low speeds, excessive temperature rise may be a limiting factor.

**Special Note:** The listed maximum allowable temperature rise for any particular blower & exhauster may occur well before its maximum pressure or vacuum rating is reached. This may occur at high altitude, low vacuum or at very low speed. The units' operating limit is always determined by the maximum rating reached first. It can be any one of the three: Pressure, Temperature or Speed.

## Lubrication

---

### For Units with Splash Lubrication on Both Ends

Bearings and oil seals are lubricated by the action of the timing gears or oil slingers which dip into the main oil sumps

causing oil to splash directly on gears and into bearings and seals. A drain port is provided below each bearing to prevent an excessive amount of oil in the bearings. Seals located inboard of the bearings in each headplate effectively retain oil within the sumps. Any small leakage that may occur should the seals wear passes into a cavity in each vented headplate and is drained downward.

Oil sumps on each end of the blower are filled by removing top vent plugs, Item (25), and filling until oil reaches the middle of the oil level sight gauge when the unit is not operating, Item (45 or 53), DO NOT FILL PAST THE MIDDLE OF THE SIGHT GLASS.

Initial filling of the sumps should be accomplished with the blower not operating, in order to obtain the correct oil level. Approximate oil quantities required for blowers of the various models and configurations are listed in Table 3. Use a good grade of industrial type non-detergent, rust inhibiting, anti-foaming oil and of correct viscosity per Table 2. **\*ROOTS synthetic oil (Roots P/N 813-106-) is specified and recommended.** Roots does not recommend automotive type lubricants, as they are not formulated with the properties mentioned above.

The oil level may rise or fall on the gauge during operation, to an extent depending somewhat on oil temperature and blower speed.

Proper lubrication is usually the most important single consideration in obtaining maximum service life and satisfactory operation from the unit. Unless operating conditions are quite severe, a weekly check of oil level and necessary addition of lubricant should be sufficient. During the first week of operation, check the oil levels in the oil sumps about once a day, and watch for leaks. Replenish as necessary. Thereafter, an occasional check should be sufficient. It is recommended that the oil be changed after initial 100 hours of operation. Frequent oil changing is not necessary unless the blower is operated in a very dusty location.

Normal life expectancy of petroleum based oils is about 2000 hours with an oil temperature of about 180°F (82°C). As the oil temperature increases by increments of 15-18°F (8°C - 10°C), the life is reduced by half. Example: Oil temperatures of 210-216°F (99°C - 102°C) will produce life expectancy of 1/4 or 500 hours. Therefore, it is considered normal to have oil change periods of 500 hours with petroleum based oils.

Normal life expectancy of ROOTS™ Synthetic Oil is about 4000 to 8000 hours with an oil temperature of about 180°F (82°C). As the oil temperature increases by increments of 15-18°F (8°C - 10°C), the life is reduced by half. Example: Oil temperatures of 210-216°F (99°C - 102°C) will produce life expectancy of 1/4 or 1000 to 2000 hours.

NOTE: To estimate oil temperature, multiply the discharge temperature of the blower by 0.80. Example: if the discharge air temperature of the blower is 200° F, it is estimated that the oil temperature is 160° F.

\*ROOTS™ Synthetic Oil & Grease is superior in performance to petroleum based products. It has high oxidation stability, excellent corrosion protection, extremely high film strength and low coefficient of friction. Typical oil change intervals are increased 2-3 times over petroleum based lubricants. Also, ROOTS™ Synthetic Oil is 100% compatible with petroleum based oils. Simply drain the oil in the blower and refill the reservoirs with ROOTS™ Synthetic Oil to maintain optimum performance of your ROOTS™ blower.

## Operation

Before operating a blower under power for the first time, recheck the unit and the installation thoroughly to reduce the likelihood of avoidable troubles. Use the following procedure check list as a guide, but consider any other special conditions in the installation.

- Be certain that no bolts, tools, rags, or debris have been left in the blower air chamber or piping.
- If an outdoor intake without filter is used, be sure the opening is located so it cannot pick up dirt and is protected by a strong screen or grille. Use of the temporary protective screen as described under INSTALLATION is strongly recommended.
- Recheck blower leveling, drive alignment and tightness of all mounting bolts if installation is not recent. If belt drive is used, adjust belt tension correctly.
- Turn drive shaft by hand to make sure impellers still rotate without bumping or rubbing at any point.
- Ensure oil levels in the main oil sumps are correct.
- Check lubrication of driver. If it is an electric motor, be sure that power is available and that electrical overload devices are installed and workable.
- Open the manual unloading valve in the discharge air line. If a valve is in the inlet piping, be sure it is open.
- Bump blower a few revolutions with driver to check that direction of rotation agrees with arrow near blower shaft, and that both coast freely to a stop.

After the preceding points are cleared, blower is ready for trial operation under "no-load" conditions. The following procedure is suggested to cover this initial operation test period.

- a. Start blower, let it accelerate to full speed, then shut off. Listen for knocking sounds, both with power on and as speed slows down.
- b. After blower comes to a complete stop, repeat above, but let blower run 2 or 3 minutes. Check for noises, such as knocking sounds.
- c. After blower comes to a complete stop, operate blower for about 10 minutes unloaded. Check oil levels. Observe cylinder and headplate surfaces for development of hot spots such as burned paint, indicating impeller rubs. Be aware of any noticeable increase in vibration.

Assuming that all trials have been satisfactory, or that necessary corrections have been made, the blower should now have a final check run of at least one hour under normal operating conditions. After blower is restarted, gradually

close the discharge unloading valve to apply working pressure. At this point it is recommended that a pressure gauge or manometer be connected into the discharge line if not already provided, and that thermometers be in both inlet and discharge lines. Readings from these instruments will show whether pressure or temperature ratings of the blower are being exceeded.

During the final run, check operating conditions frequently and observe the oil levels at reasonable intervals. If excessive noise or local heating develops, shut down immediately and determine the cause. If either pressure rise or temperature rise across the blower exceeds the limit specified in this manual, shut down and investigate conditions in the piping system. Refer to the TROUBLESHOOTING CHECKLIST for suggestions on various problems that may appear.

The blower should now be ready for continuous duty operation at full load. During the first few days make periodic checks to determine whether all conditions remain steady, or at least acceptable. This may be particularly important if the blower is supplying air to a process system where conditions can vary. At the first opportunity, stop the blower and clean the temporary inlet protective screen. If no appreciable amount of debris has collected, the screen may be removed. See comments under INSTALLATION. At this same time, verify leveling, coupling alignment or belt tension, and mounting bolt tightness.

Should operating experience prove that blower capacity is a little too high for the actual air requirements, a small excess may be blown off continuously through the manual unloading or vent valve. Never rely on the pressure relief valve as an automatic vent. Such use may cause the discharge pressure to become excessive, and can also result in failure of the valve itself. If blower capacity appears to be too low, refer to the TROUBLESHOOTING CHECKLIST.

### Vibration Assessment Criteria

With measurements taken at the bearing locations on the housings, see chart below for an appropriate assessment guide for rotary lobe blowers rigidly mounted on stiff foundations.

In general, blower vibration levels should be monitored on a regular basis and the vibration trend observed for progressive or sudden change in level. If such a change occurs, the cause should be determined through spectral analysis.

As shown on the chart below, the level of all pass vibration will determine the need to measure discrete frequency vibration levels and the action required.

All Pass Vibration (in/sec)	Discrete Frequency Vibration (in/sec)	Action
0.45 or less	N/R	Acceptable
Greater than 0.45 but 1.0 or less	0.45 or less @ any frequency Greater than 0.45 @ any frequency	Acceptable Investigate
Greater than 1.0	Less than 1.0 Greater than 1.0	Investigate Investigate

## Troubleshooting Checklist

Trouble	Item	Possible Cause	Remedy
No flow	1	Speed too low	Check by tachometer and compare with published performance
	2	Wrong rotation	Compare actual rotation with Figure 1 Change driver if wrong
	3	Obstruction in piping	Check piping, valves, silencer to assure open flow path
Low capacity	4	Speed too low	See item 1, If belt drive, check for slippage and readjust tension
	5	Excessive pressure rise	Check inlet vacuum and discharge pressure and compare with Published performance
	6	Obstruction in piping	See item 3
	7	Excessive slip	Check inside of casing for worn or eroded surfaces causing excessive clearances
Excessive power	8	Speed too high	Check speed and compare with published performance
	9	Excessive pressure rise	See Item 5
	10	Impeller rubbing	Inspect outside of cylinder for high temperature areas, then check for impeller contact at these points. Correct blower mounting, drive alignment
	11	Scale, sludge, rust or product build up	Clean blower appropriately
Damage to bearings or gears	12	Inadequate lubrication	Check oil sump levels in gear and drive end headplates
	13	Excessive lubrication	Check oil levels. If correct, drain and refill with clean oil of recommended grade
	14	Excessive pressure rise	See Item 5
	15	Coupling misalignment	Check carefully. Realign if questionable
	16	Excessive belt tension	Readjust for correct tension
Vibration	17	Misalignment	See Item 15
	18	Impellers rubbing	See Item 10
	19	Worn bearings/gears	Check gear backlash and condition of bearings, and replace as indicated
	20	Unbalanced or rubbing impeller	Scale or process material may build up on casing and impellers, or inside impellers. Remove build-up to restore original clearances and impeller balance
	21	Driver or blower loose	Tighten mounting bolts securely
	22	Piping resonances	Determine whether standing wave pressure pulsations are present in the piping
	23	Scale/sludge build-ups	Clean out interior of impeller lobes to restore dynamic balance
Driver stops, or will not start	24	Casing strain	Re-work piping alignment to remove excess strain
	25	Impeller stuck	Check for excessive hot spot on headplate or cylinder. See item 10. Look for defective shaft bearing and/or gear teeth
	26	Scale, sludge, rust or product build-up	Clean blower appropriately
Excessive breather Blow-by or excessive oil leakage to vent area	27	Broken seal	Replace seals
	28	Defective O-ring	Replace seals and O-ring
Excessive oil leakage in vent area	29	Defective/plugged breather	Replace breather and monitor oil leakage
	30	Oil level too high	Check sump levels in gear and drive headplates.
	31	Oil type or viscosity incorrect	Check oil to insure it meets recommendations. Drain then fill with clean oil of recommended grade.
	32	Blower running hot	Check blower operating conditions to ensure they are within the operating limitations defined in this manual.



## Inspection & Maintenance: Universal RAI® series blowers

A good program of consistent inspection and maintenance is the most reliable method of minimizing repairs to a blower. A simple record of services and dates will help keep this work on a regular schedule. Basic service needs are:

- Lubrication
- Checking for hot spots
- Checking for increases or changes in vibration and noise
- Recording of operating pressures and temperatures

Above all, a blower must be operated within its specified rating limits, to obtain satisfactory service life.

A newly installed blower should be checked often during the first month of full-time operation. Attention there after may be less frequent assuming satisfactory performance. Lubrication is normally the most important consideration and weekly checks of lubricant levels in the gearbox and bearing reservoirs should be customary. Complete oil change schedules are discussed under **LUBRICATION**.

Driver lubrication practices should be in accordance with the manufacturer's instructions. If direct connected to the blower through a lubricated type coupling, the coupling should be checked and greased each time blower oil is changed. This will help reduce wear and prevent unnecessary vibration. In a belted drive system, check belt tension periodically and inspect for frayed or cracked belts.

In a new, and properly installed, unit there is no contact between the two impellers, or between the impellers and cylinder or headplates. Wear is confined to the bearings (which support and locate the shafts) the oil seals, and the timing gears. All are lubricated and wear should be minimal if clean oil of the correct grade is always used. Seals are subject to deterioration as well as wear, and may require replacement at varying periods.

Shaft bearings are designed for optimum life under average conditions with proper lubrication and are critical to the service life of the blower. Gradual bearing wear may allow a shaft position to change slightly, until rubbing develops between impeller and casing. This will cause spot heating, which can be detected by observing these surfaces. Sudden bearing failure is usually more serious. Since the shaft and impeller are no longer supported and properly located, extensive general damage to the blower casing and gears is likely to occur.

Oil seals should be considered expendable items, to be replaced whenever drainage from the headplate vent cavity becomes excessive or when the blower is disassembled for

any reason. Some oil seal leakage may occur since an oil film under the lip is required for proper operation. Periodically leaked oil should be wiped off from surfaces. Minor seal leakage should not be considered as indicating seal replacement.

Timing gear wear, when correct lubrication is maintained, should be negligible. Gear teeth are cut to provide the correct amount of backlash, and gears correctly mounted on the shafts will accommodate a normal amount of tooth wear without permitting contact between lobes of the two impellers. However, too high an oil level will cause churning and excessive heating. This is indicated by unusually high temperature at the bottom of the gear housing. Consequent heating of the gears will result in loss of tooth-clearance, backlash and rapid wear of the gear teeth usually will develop. Continuation of this tooth wear will eventually produce impeller contacts (knocking), and from this point serious damage will be unavoidable if blower operation is continued. A similar situation can be produced suddenly by gear tooth fracture, which is usually brought on by sustained overloading or momentary shock loads.

Problems may also develop from causes other than internal parts failure. Operating clearances within a blower are only a few thousandths of an inch. This makes it possible for impeller interference or casing rubs to result from shifts in the blower mounting, or from changes in piping support. If this type of trouble is experienced, and the blower is found to be clean, try removing mounting strains. Loosen blower mounting bolts and reset the leveling and drive alignment. Then tighten mounting again, and make sure that all piping meets blower connections accurately and squarely. Foreign materials in the blower will also cause trouble, which can only be cured by disconnecting the piping and thoroughly cleaning the blower interior.

A wide range of causes & solutions for operating troubles are covered in the **TROUBLE SHOOTING CHECKLIST**. The remedies suggested should be performed by qualified mechanics with a good background. Major repairs generally are to be considered beyond the scope of maintenance, and should be referred to an authorized Roots distributor.

Warranty failures should not be repaired at all, unless specific approval has been obtained through Roots before starting work. Unauthorized disassembly within the warranty period may void the warranty.

Drive End Breather Orientation for URA-DSL blowers with Oil Lube

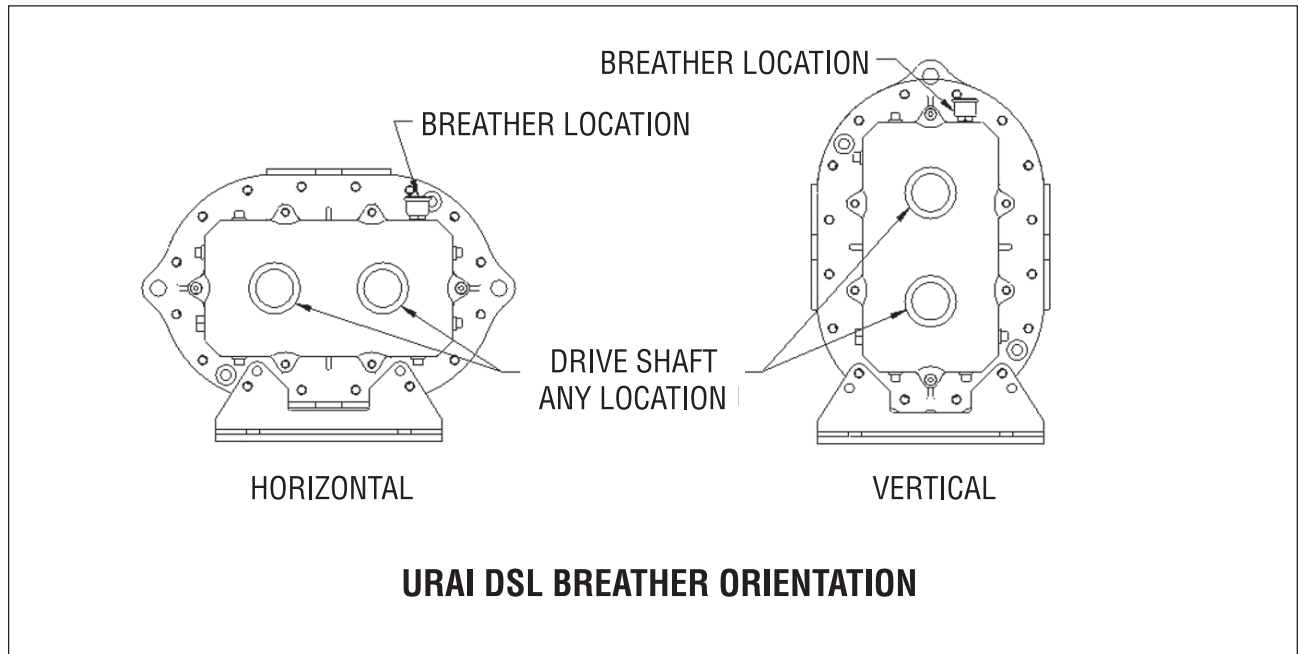

Table 1 - URAI, URAI-DSL Blowers,  
Maximum Allowable Operating Conditions

Frame Size	Gear Diameter (Inch)	Speed RPM	Temp. Rise Deg F (Deg C)	Delta Pressure PSI (mbar)	Inlet Vacuum INHG (mbar)
47	4	3,600	225 (125)	7 (483)	15 (500)

**Table 2 - Recommended Oil Grades**

Ambient Temperature °F (°C)	ISO Viscosity No.
Above 90° (32°)	320
32° to 90° (0° to 32°)	220
0° to 32° (-18° to 0°)	150
Below 0° (-18°)	100

Ambient temperature is defined as the temperature of the space in which the blower and drive are located.

**Table 3 - Approximate Oil Sump Capacities**

These capacities are provided to assist in stocking the correct amount of oil. Exact sump capacities may differ slightly. See "Lubrication" section for proper filling instructions.

**URAI-DSL Splash Lubricated Blowers**

Frame Size	Gear End Capacity Fl. Oz (Liters)	Drive End Capacity Fl. Oz. (Liters)
47	22.8 (.67)	10.8 (.32)

Basic Connection & Drive Shaft Information

**URAI DSL AIR BLOWERS (with Dual Splash Lubrication DSL)**

BOM#	FRAME SIZE	INLET/DISCHARGE CONN.	SHAFT DIAMETER	BARE WEIGHT
T30354020	47	3" NPT	.0875"	132

Universal RAI air blowers include detachable mounting feet which permit vertical or horizontal installation. The units are center timed for rotation in either direction. The bearings on the URAI are grease lubricated on the drive end and splash lubricated on the gear end. The URAI-DSL is splash lubricated on BOTH ends.

**PAGE LEFT BLANK**

# WIRING SCHEMATIC

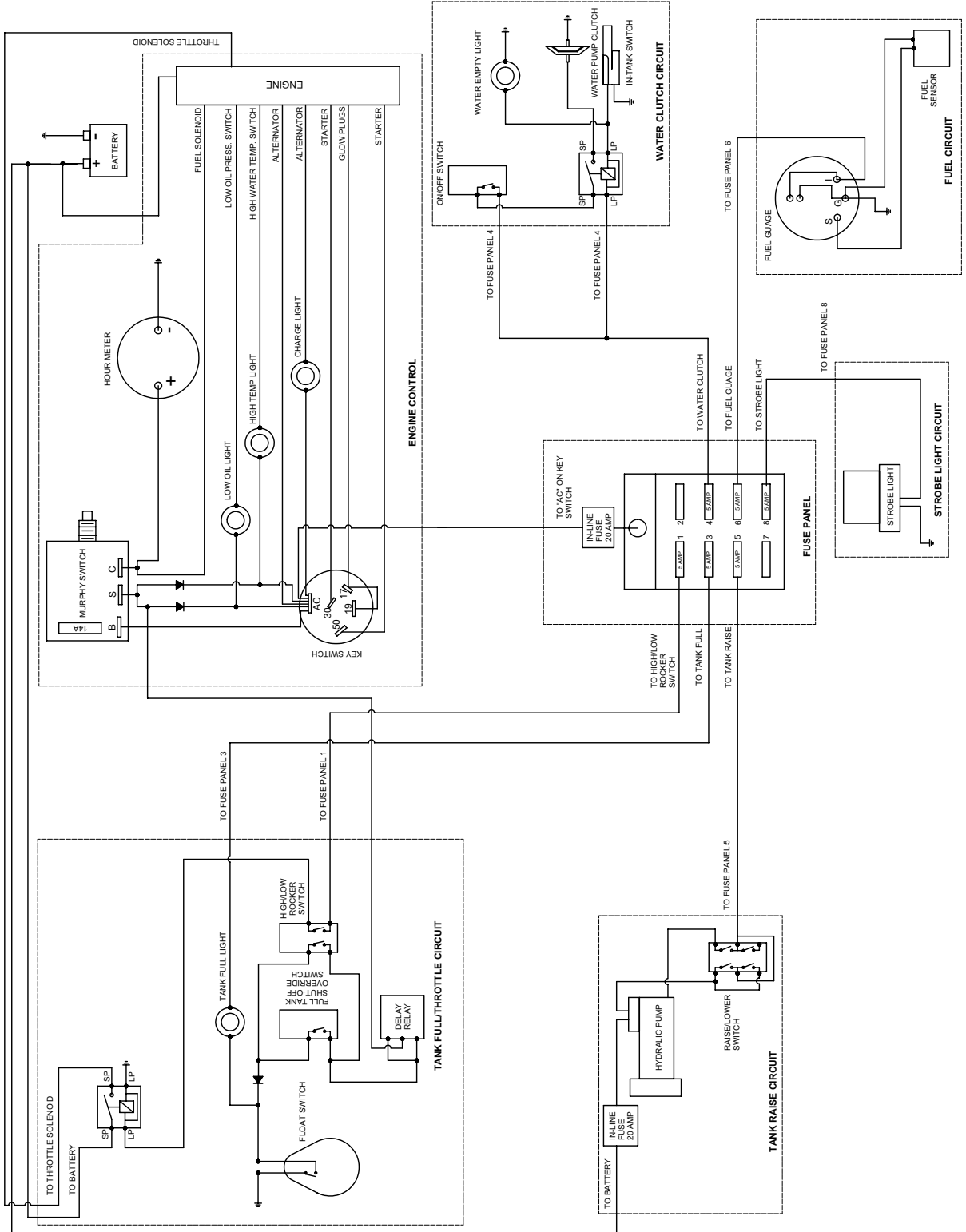

**PAGE LEFT BLANK**

# WARRANTY RETURN GOODS POLICY

## LIMITED WARRANTY

The Manufacturer warrants its products to be free from defects in material and workmanship for a period of twelve months from the date of shipment from the factory. The Manufacturer shall not be responsible for any damage resulting to or caused by its products by reason of installation, improper storage, unauthorized service, alteration of the products, neglect or abuse, or use of the product in a manner inconsistent with its design. The warranty does not extend to any component parts not manufactured by Manufacturer; however, Manufacturer's warranty herein shall not limit any warranties made by manufacturers of component parts which extend to Buyer.

Claims for defects in material and workmanship shall be made in writing to Manufacturer within ten days of discovery of defect. Manufacturer may either send a service representative or have the product returned to its factory at Buyer's expense for inspection. Upon notification of defect, Manufacturer will issue a return goods authorization number to Buyer. The return goods authorization number must accompany the product returned. If judged by the Manufacturer to be defective in material or workmanship, the product will be replaced or repaired at the option of the Manufacturer, free from all charges except authorized transportation. Buyer shall be responsible for all maintenance services consisting of lubrication and cleaning of equipment, replacing expandable parts, making minor adjustments, and performing operating checks, all in accordance with procedures outlined in Manufacturer's maintenance literature.

THE FOREGOING WARRANTY IS IN LIEU OF ALL OTHER WARRANTIES AND NO REPRESENTATIONS, GUARANTEES, OR WARRANTIES, EXPRESS OR IMPLIED, (INCLUDING BUT NOT LIMITED TO A WARRANTY OF MERCHANTABILITY OR FITNESS FOR A PARTICULAR PURPOSE), ARE MADE BY THE MANUFACTURER IN CONNECTION WITH THE MANUFACTURE OR SALE OF ITS PRODUCTS. NO EMPLOYEE, DISTRIBUTOR, OR REPRESENTATIVE IS AUTHORIZED TO CHANGE THIS WARRANTY ON BEHALF OF MANUFACTURER. THE REMEDIES OF BUYER SET FORTH HEREIN ARE EXCLUSIVE AND ARE IN LIEU OF ALL OTHER REMEDIES. THE LIABILITY OF MANUFACTURER WHETHER IN CONTRACT, TORT, UNDER ANY WARRANTY, OR OTHERWISE SHALL NOT EXTEND BEYOND ITS OBLIGATION TO REPAIR OR REPLACE, AT ITS OPTION ANY PRODUCT OR PART FOUND BY MANUFACTURER TO BE DEFECTIVE IN MATERIAL OR WORKMANSHIP. MANUFACTURER SHALL NOT BE LIABLE FOR COST OF INSTALLATION AND/OR REMOVAL OR BE RESPONSIBLE FOR DIRECT, INDIRECT, SPECIAL OR CONSEQUENTIAL DAMAGES OF ANY NATURE.

## GENERAL RETURNS OF MERCHANDISE

1. All returns must be pre-authorized
  - A. Please call our parts department for an RGA number
  - B. Please include RGA number on the outside of box
  - C. Include any required paper work or special instructions
  - D. Items returned without an RGA number will not be accepted
2. All returns are subject to a 20% restock charge.
3. Special items are non-returnable
  - A. Non-stock parts
  - B. Custom parts
  - C. If you are unsure about a parts status when ordering, ask your McLaughlin representative if the item fits on of the above conditions.
4. Items must be returned within thirty days of original order date.
5. Items not returned within 30 days from the date of RGA is issued will not be accepted.
6. The item(s) must be in new condition. Used item(s) are not returnable.





