



McLAUGHLIN[®]

2006 Perimeter Road. Greenville, SC 29605

Toll Free: 800/435-9340 - Phone: 864/277-5870

Fax: 864/235-9661 - Website address: www.mclaughlinunderground.com

Email address: mmole@mightymole.com

Parts Manual
Vermeer/ McLaughlin
SKID V800HD Vacuum Machine
Part #E850610
(Serial Number Ending S8H121312364 -
S8H050813642)

© 2013 by McLaughlin Group, Inc.

041213

All rights reserved. No part of this manual may be reproduced in any form, or by any means without prior written permission of McLaughlin Group, Inc.



Table of Contents

PARTS

SPOIL TANK AND FILTRATION

| | |
|------------------------------|---|
| HYDRAULIC DOOR | 4 |
| HYDRAULIC DOOR CYLNDER | 6 |
| FILTRATION | 8 |

ENGINE COMPARTMENT

| | |
|---------------------------|----|
| ENCLOSURE | 10 |
| ENGINE | 18 |
| BLOWER | 26 |
| WATER PUMP | 46 |
| REGULATOR | 64 |
| ELECTRICAL | 70 |
| HYDRAULIC POWERPACK | 74 |
| HYDRAULIC PUMP | 80 |

WATER TANK AND ACCESSORIES

| | |
|---------------------------------------|----|
| WATER TANKS - 125 GALLON SADDLE | 84 |
| WATER TANKS - 230 GALLON | 86 |
| WATER TANKS - 410 GALLON | 88 |
| WATER TANKS - 205 GALLON SADDLE | 90 |
| HOSE REEL | 92 |

TRAILER AND SKID ASSEMBLY

| | |
|---------------------|-----|
| ANTI-FREEZE | 96 |
| SKID ASSEMBLY | 98 |
| HOSES | 102 |

TOOLS

| | |
|-------------------------------|-----|
| TOOL RACK | 104 |
| REDUCTION TOOL | 108 |
| VACUUM TOOL | 110 |
| WASH WAND | 112 |
| VALVE BOX CLEANOUT TOOL | 114 |
| ROTARY LANCE | 116 |
| LAWN SWEEPER | 120 |
| SURFACE CLEANER | 122 |

OPTIONS

| | |
|---------------------|-----|
| BOOM | 124 |
| HOT BOX | 136 |
| JETTER | 138 |
| ARROWBOARD | 142 |
| AUX HYDRAULIC | 144 |

ELECTRICAL SCHEMATICS

| | |
|----------------------------|-----|
| VACUUM DIESEL ENGINE | 147 |
| BOOM | 153 |
| ARROWBOARD | 155 |
| HOT BOX | 157 |
| JETTER | 159 |

HYDRAULIC SCHEMATICS

| | |
|------------|-----|
| BOOM | 161 |
|------------|-----|

MAINTENANCE MANUALS

| | |
|--------------------|-----|
| ROOTS BLOWER | 164 |
| HOT BOX | 194 |
| ENGINE | 204 |

WARRANTY

Tank and Door Assembly

800

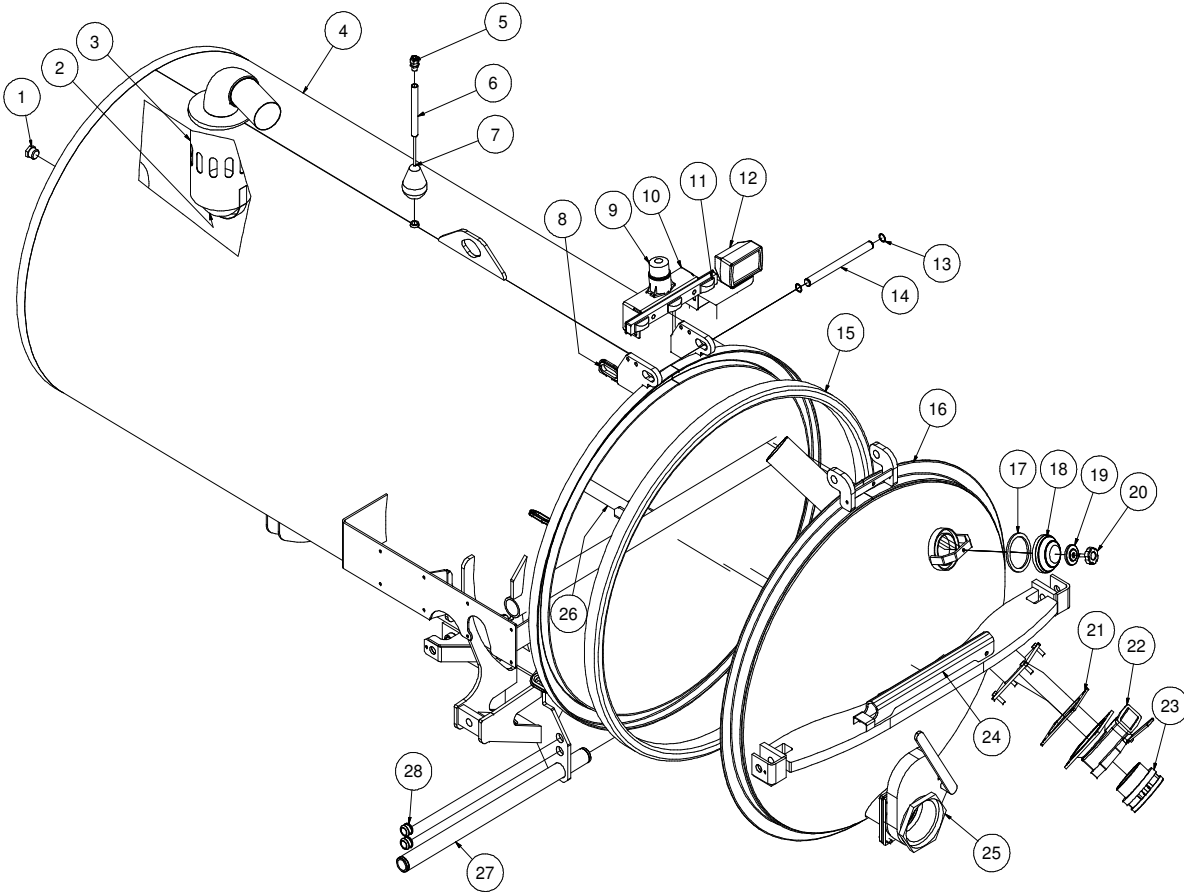

101912-E

VACASSY035

Tank and Door Assembly

800

| ITEM | QTY | PART NO. | DESCRIPTION |
|------|-----|----------|---|
| 1 | 1 | T405120 | 1" PLUG MB |
| 2 | 1 | 8043570 | BALL STRAINLESS FLOAT 6" |
| 3 | 1 | 8043700 | BALL FLOAT SHUTOFF WELDMENT |
| | 2 | U000420 | SCREW,HC 3/8"-16 X 1.00" |
| | 2 | U210060 | WASHER, LOCK 3/8" |
| | 2 | U200600 | WASHER, FLAT 3/8" |
| | 1 | 8043571 | SEAT, 4" RUBBER |
| | 1 | 8043572 | SEAT CLAMP 4" |
| 4 | 1 | 8046150 | TANK WELDMENT 800 |
| 5 | 1 | X000113 | STRAIN RELIEF, 1/2" |
| 6 | 1 | 8040769 | HIGH LEVEL FLOAT SWITCH TUBE |
| | 1 | 8041291 | BUSHING, RUBBER |
| 7 | 1 | 8030531 | HIGH LEVEL FLOAT SWITCH |
| 8 | 4 | 8042812 | GROMMET, 2"ID 3"OD 1/4"WOG TRAILER SLOT MODEL |
| 9 | 1 | 8043139 | STROBE LIGHT |
| | 3 | U010006 | SCREW, PHILLIP #10-24 X 1.00" |
| | 3 | U210005 | WASHER, LOCK #10 |
| | 3 | U100010 | NUT, HEX #10-24 |
| 10 | 1 | 8046507 | STROBE LIGHT BRACKET |
| | 4 | X000343 | DT MOUNTING CLIP |
| | 4 | U000880 | SCREW, HC 1/2"-13 X 2.00" |
| | 4 | U200100 | WASHER, FLAT 1/2" |
| | 4 | U210111 | WASHER, LOCK 1/2" |
| | 4 | U100200 | NUT, HEX 1/2"-13 |
| 11 | 1 | 8041509 | LIGHT CLEARANCE 3 BAR |
| 12 | 1 | 8043138 | WORK LIGHT |
| 13 | 2 | 8030362 | 1" SNAP RING |
| 14 | 1 | 8040058 | DOOR HINGE ROD |
| 15 | 1 | 8041766 | SEAL, DOOR SQ 750/800LE |
| 16 | 1 | 8047771 | DOOR, HYD 800 SKID WELDMENT |
| 17 | 1 | 8031049 | GASKET, 4" COUPLER |
| 18 | 1 | 8031048 | SIGHT GLASS |
| 19 | 1 | 8031047 | SIGHT GLASS PLATE |
| 20 | 1 | 8031046 | SIGHT GLASS HAND WHEEL |
| 21 | 2 | 8046191 | GASKET, DOOR INLET/OUTLET |
| 22 | 1 | 8046215 | VALVE, 4" GATE BRASS LEVER FLANGE |
| | 1 | 8046231 | O-RING, GATE VALVE |
| 23 | 1 | 8046445 | CAMLOCK, 4"MCAM X MNPT |
| 24 | 1 | 8041212 | TANK SAFETY BRACE |
| 25 | 1 | 8046214 | VALVE, 6" GATE BRASS LEVER |
| 26 | 1 | 8046172 | TANK ROD 800LE WELDMENT |
| 27 | 1 | 8030038 | TANK PIVOT ROD |
| 28 | 4 | 8041686 | GROMMET, 1"ID - 1 1/4"WOG - 1/4"WO |

* NOT SHOWN

Hyd. Door Cylinder Assembly

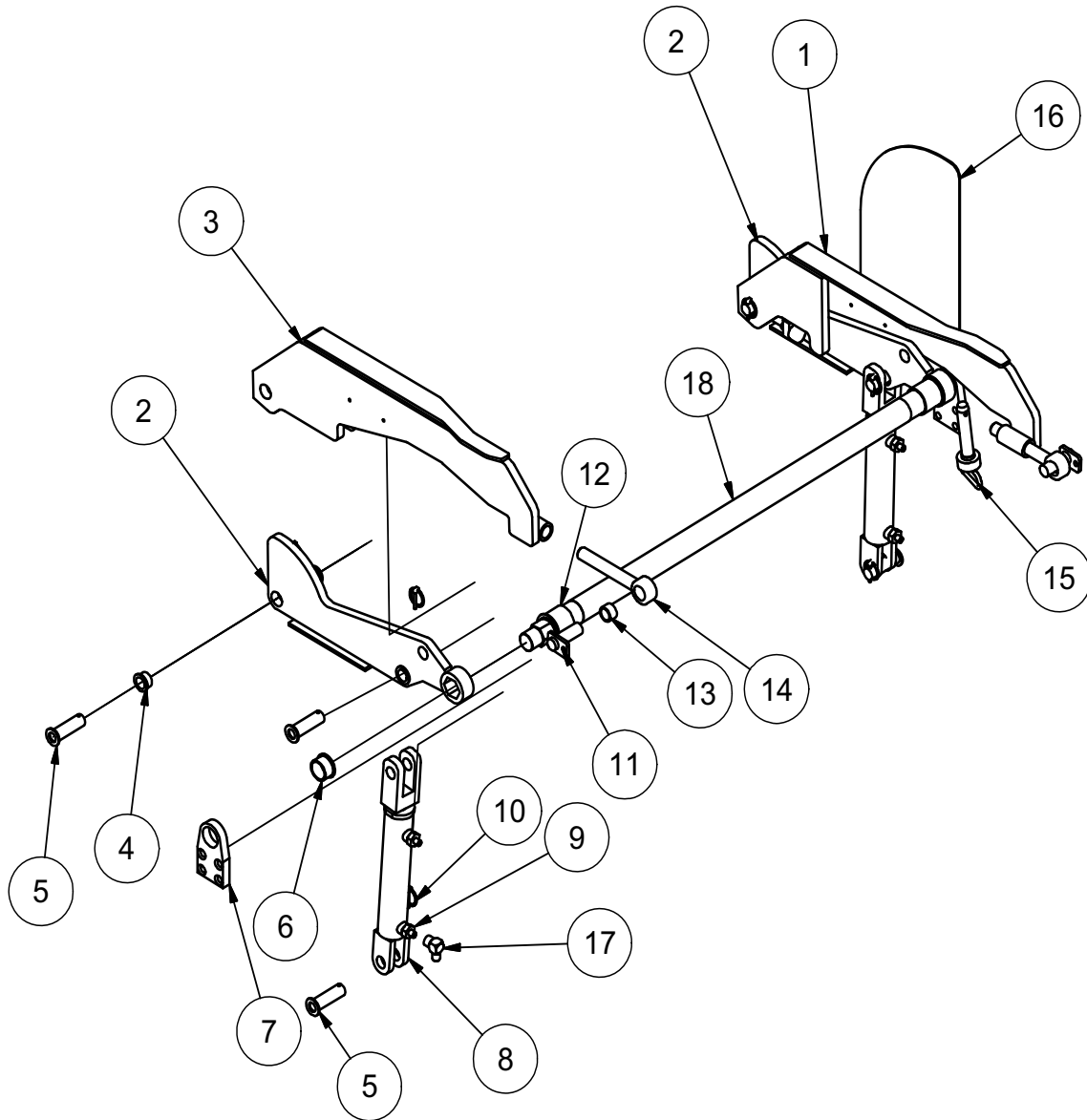

080311-E

VACASSY942

Hyd. Door Cylinder Assembly

| ITEM | QTY | PART NO. | DESCRIPTION |
|------|-----|----------|---------------------------------------|
| 1 | 1 | 8041369 | DOOR HYD LONG LINKAGE WELDMENT |
| 2 | 2 | 8041604 | SHORT LINKAGE WELDMENT |
| 3 | 1 | 8041375 | DOOR HYD LONG LINKAGE SS WELDMENT |
| 4 | 6 | 8041883 | BUSHING BRONZE FLANGED 1" |
| 5 | 6 | 8042489 | HYD DOOR - PIN WELDMENT 1"DIA X 3" |
| 6 | 2 | 8041602 | BUSHING 1 1/4" MODIFIED |
| 7 | 1 | 8041783 | OUTER BEARING PLATE |
| 8 | 2 | 8041327 | HYD CYLINDER - 8" STROKE |
| 9 | 4 | T400611 | UNION 8MB - 4MJ |
| 10 | 6 | U340050 | PIN LINCH 3/16 X 1 9/16 |
| 11 | 2 | 8043844 | DOOR CAPTURE PIN |
| 12 | 2 | 8041602 | BUSHING BRONZE FLANGED 2" |
| 13 | 2 | 8041524 | BUSHING BRONZE 1 1/4" X 1.00 X 3/4"LG |
| 14 | 2 | 8043131 | ROD END 1" X 7 1/2" |
| | 2 | U160025 | NUT, JAM 1.00" |
| | 2 | U120060 | NUT, NY LOCK 1" |
| | 4 | U200170 | WASHER, FLAT 1.00" |
| 15 | 1 | 8041626 | 1" X 4 1/2" HITCH PIN |
| 16 | 1 | 8041635 | HYD ARM GUARD |
| 17 | 1 | T401225 | ELBOW, 90 1/4MJ - 1/4FJ |
| 18 | 1 | 8041607 | LINKAGE CROSS TUBE V500 |
| | 1 | 8046186 | LINKAGE CROSS TUBE V750 / V800LE |
| | 1 | 8041663 | LINKAGE CROSS TUBE V800 / V1200 |

Filtration

HD

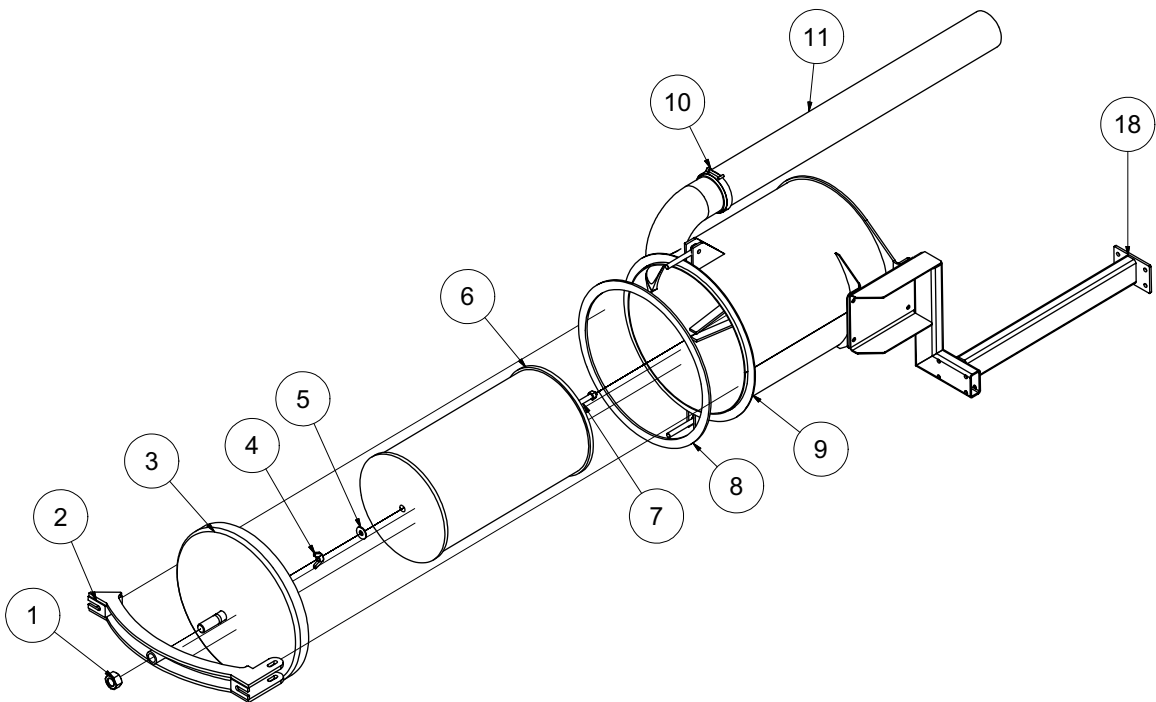
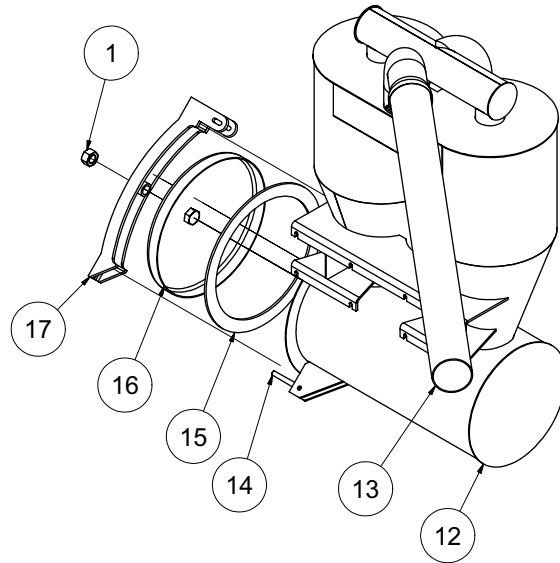

041212-E

VACASSY347

Filtration

HD

| ITEM | QTY | PART # | DESCRIPTION |
|------|-----|---------|-------------------------------------|
| 1 | 2 | U120060 | NUT, LOCK NY 1" - 8 |
| 2 | 1 | 8041554 | DOOR LATCH (HD AIR FILTER WELDMENT) |
| 3 | 1 | 8041387 | HD AIR FILTER DOME ASSY |
| 4 | 1 | U130080 | NUT, WING 1/2" - 13 |
| 5 | 1 | U200100 | WASHER, FLAT 1/2" |
| 6 | 1 | 8031293 | WASHABLE AIR FILTER ELEMENT |
| 7 | 1 | 8040302 | THREADED ROD - 4"LG |
| 8 | 1 | 8041613 | SEAL 3/8" EPDM 17. |
| 9 | 1 | 8046338 | HD AIR FILTER HOUSING |
| * | 10 | U200060 | WASHER, FLAT .375 |
| * | 1 | U000520 | SCREW, HC 3/8" - 16 X 2.25" |
| * | 1 | U000580 | SCREW, HC 3/8" - 16 X 3.50" |
| * | 4 | U000420 | SCREW, HC 3/8"-16 X 1.00" |
| * | 8 | U000440 | WASHER, FLAT 3/8" |
| * | 4 | U120110 | NYLON LOCKNUT 3/8"-16 |
| * | 2 | 8041594 | HANDLE, WING |
| 10 | 4 | 8042606 | CLAMP T-BOLT (450) |
| 11 | 1 | 8046804 | HOSE VAC AG SUCTION 4-189" (V500) |
| | 1 | 8046805 | HOSE VAC AG SUCTION 4-206" (V800) |
| | 1 | 8046998 | HOSE VAC AG SUCTION 4-156" (VSK300) |
| 12 | 1 | 8046458 | HD SEPARATOR - HOUSING ONLY |
| * | 10 | U000440 | WASHER, FLAT 3/8" |
| * | 1 | U000520 | SCREW, HC 3/8" - 16 X 2.25" |
| * | 1 | U000580 | SCREW, HC 3/8" - 16 X 3.50" |
| * | 2 | U120110 | NYLON LOCKOUT 3/8 - 16 |
| * | 2 | 8041594 | HANDLE, WING |
| * | 8 | U000420 | SCREW, HC 3/8"-16 X 1.00" |
| * | 16 | U200060 | WASHER, FLAT 3/8" |
| * | 8 | U210061 | NYLON LOCKNUT 3/8"-16 |
| 13 | 1 | 8041781 | HOSE VAC AG SUCTION 4-48" |
| 14 | 4 | 8041593 | BOLT, EYE 1/2" - 13 X 6" |
| 15 | 1 | 8041612 | SEAL 3/8" EPDM 14"ID, 17.25"OD |
| 16 | 1 | 8041402 | HD CYCLONE DOME DOOR ASSY |
| 17 | 1 | 8041552 | DOOR LATCH (CYCLONE) - WELDMENT |
| 18 | 1 | 8046243 | AIR FILTER BRACKET LE |
| * | 4 | U210060 | WASHER, LOCK 3/8" ZP |
| * | 4 | U000441 | SCREW, HC 3/8-16 X 1.25" |
| * | 4 | U000440 | WASHER, FLAT 3/8" |
| * | 4 | U100060 | NUT, HEX 3/8"-16 |

* NOT SHOWN

041212-E

VACASSY347

Enclosure Assembly

67 HP

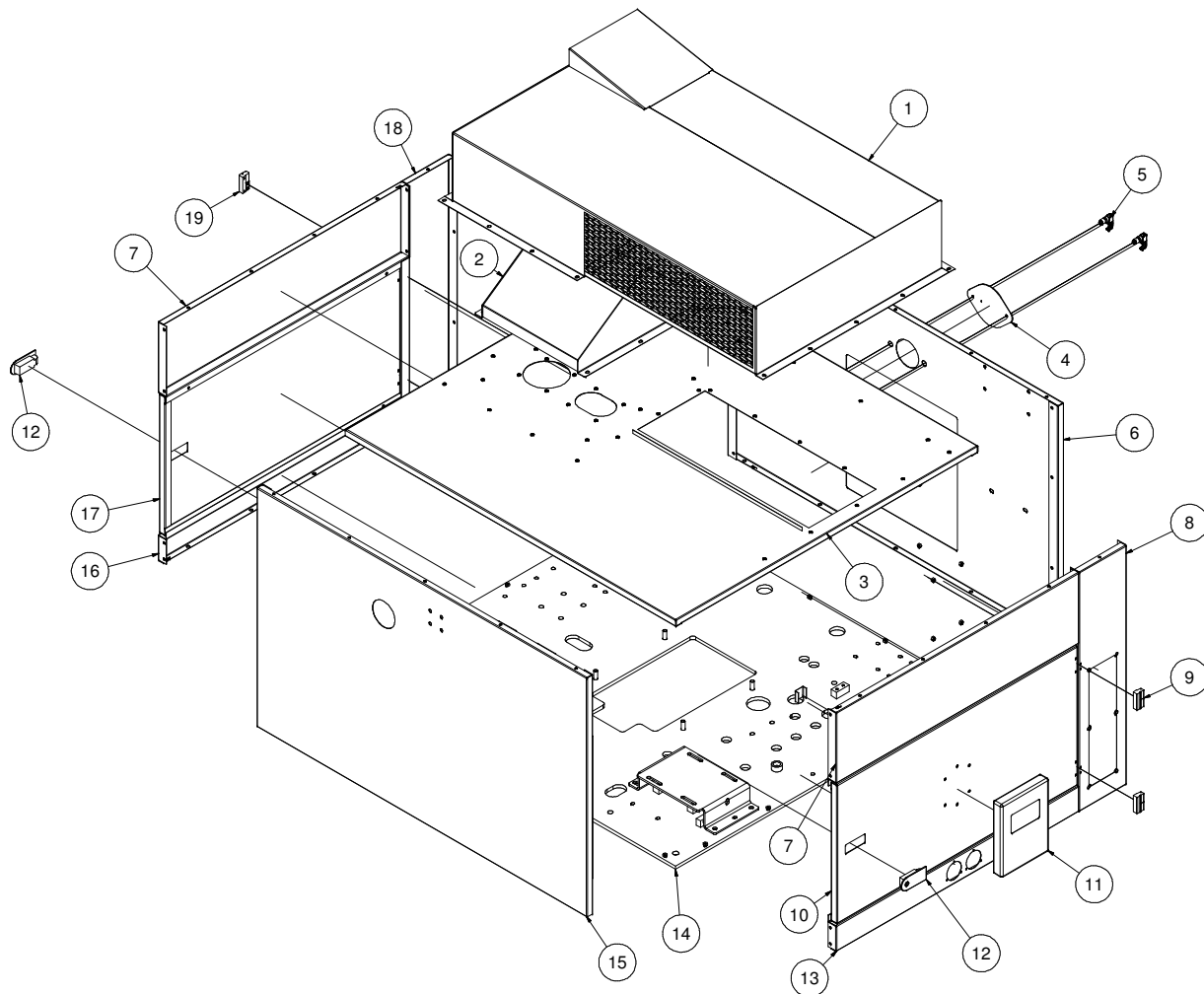

050313-E

VACASSY406

Enclosure Assembly

67 HP

| ITEM | QTY | PART # | DESCRIPTION |
|------|-----|---------|---|
| 1 | 1 | 8048983 | INTAKE BOX |
| 2 | 1 | 8044283 | EXHAUST SHEILD |
| 3 | 1 | 8044250 | PANEL TOP |
| 4 | 1 | 8040592 | RADIATOR ACCESS COVER |
| 5 | 2 | 8040334 | SWELL LATCH |
| 6 | 1 | 8044248 | PANEL FRONT |
| * | 1 | 8044301 | LS FRONT SOUND INSULATION |
| * | 1 | 8044302 | RS FRONT SOUND INSULATION |
| * | 1 | 8044930 | BELOW RADIATOR SOUND INSULATION |
| * | 1 | 8044931 | ABOVE RADIATOR SOUND INSULATION |
| 7 | 2 | 8044257 | PANEL SIDE UPPER |
| * | 2 | 8044308 | SIDE UPPER SOUND INSULATION |
| 8 | 1 | 8043614 | PANEL SIDE VERTICAL CONTROL |
| * | 1 | 8044303 | SIDE VERTICAL CONTOL PANEL SOUND INSULATION |
| 9 | 2 | 8040588 | OFFSET HINGE TYPE "A" |
| 10 | 1 | 8044260 | PANEL DOOR FOR MANUAL |
| * | 1 | 8044310 | DOOR SOUND INSULATION |
| 11 | 1 | E250211 | BOX, PLASTIC for SAFETY MANUAL |
| 12 | 2 | 8040586 | SEALED LEVER LATCH |
| | 1 | 8041816 | KEY DOOR SOUTHCO LATCH |
| 13 | 1 | 8044262 | PANEL SIDE LOWER GAUGES |
| * | 1 | 8044307 | SIDE LOWER SOUND INSULATION |
| 14 | 1 | 8047102 | MAIN PLATE |
| 15 | 1 | 8044252 | PANEL REAR |
| * | 1 | 8044306 | LS REAR SOUND INSULATION |
| * | 1 | 8044947 | RS REAR SOUND INSULATION |
| 16 | 1 | 8044254 | PANEL SIDE LOWER |
| * | 1 | 8044307 | SIDE LOWER SOUND INSULATION |
| 17 | 1 | 8044258 | PANEL DOOR |
| * | 1 | 8044309 | DOOR SOUND INSULATION |
| 18 | 1 | 8043922 | PANEL SIDE VERTICAL |
| * | 1 | 8044304 | SIDE VERTICAL SOUND INSULATION |
| 19 | 2 | 8040589 | OFFSET HINGE TYPE "B" |
| * | 20 | U000060 | SCREW, HC 1/4-20 X 1 |
| * | 36 | U000020 | SCREW, HC 1/4-20 X 1/2 |
| * | 112 | U200020 | WASHER, FLAT 1/4" |
| * | 36 | U120100 | NUT, HEX LOCK 1/4" |
| * | 1 | 8041171 | HANDLE |
| | 2 | U001017 | SCREW, HSH 1/4-20 X 1.25 |
| | 2 | U200020 | WASHER, FLAT 1/4" |
| | 2 | U120100 | NUT, HEX LOCK 1/4-20 |
| * | 2 | 8041504 | DOOR SEAL VERTICAL |
| * | 1 | 8044223 | EXHAUST FLANGE |
| * | 1 | 8048909 | EXHAUST INSULATION |

* NOT SHOWN

050313-E

VACASSY406

Enclosure Assembly

67HP RC

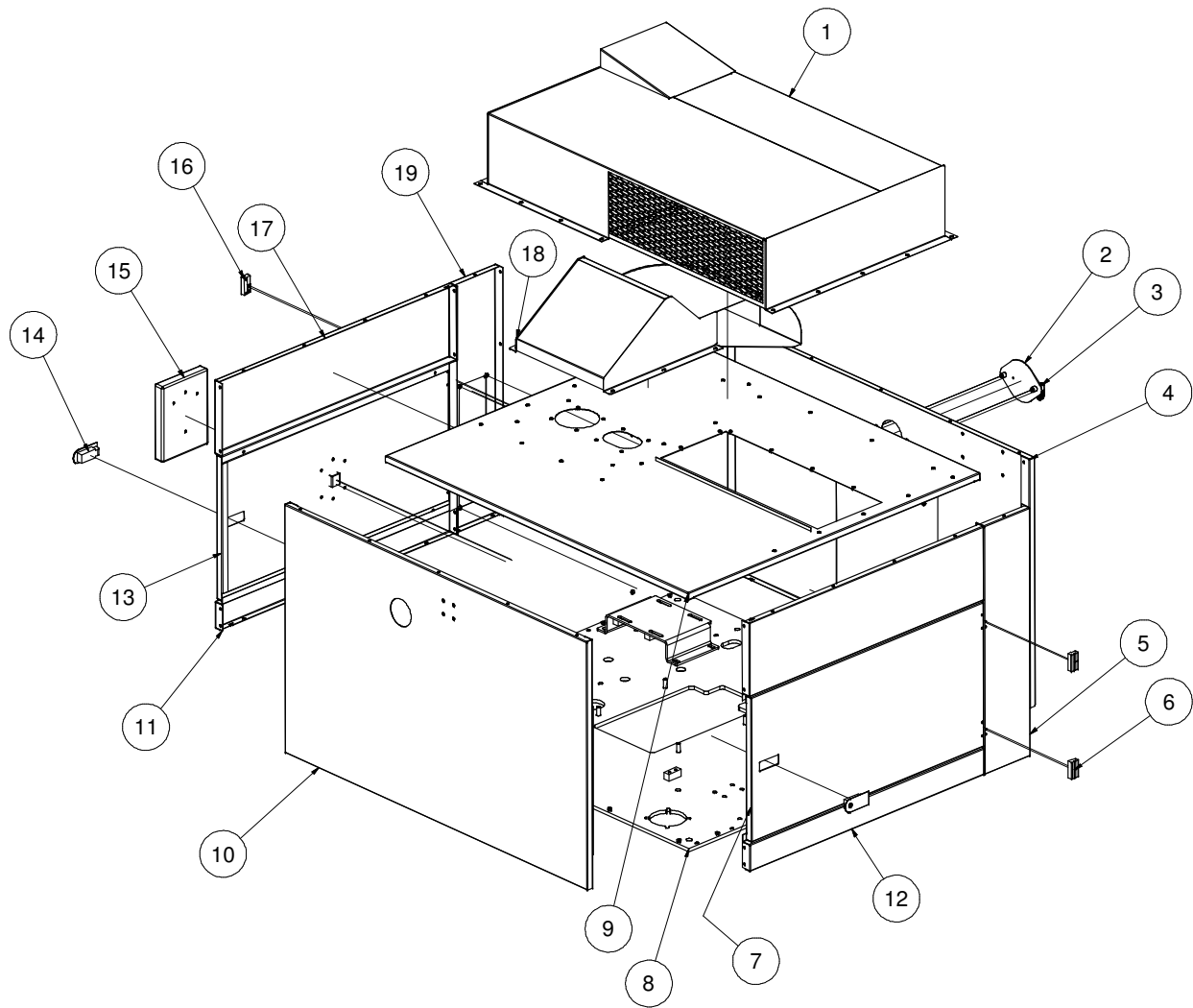

050313-E

VACASSY415

Enclosure Assembly

67HP RC

| ITEM | QTY | PART NO. | DESCRIPTION |
|------|-----|----------|--|
| 1 | 1 | 8048983 | INLET OUTLET BOX |
| 2 | 1 | 8040592 | ENCLOSURE RADIATOR COVER |
| 3 | 2 | 8040334 | SWELL LATCH |
| 4 | 1 | 8044248 | PANEL FRONT |
| * | 1 | 8044301 | LS FRONT SOUND INSULATION |
| * | 1 | 8044302 | RS FRONT SOUND INSULATION |
| * | 1 | 8044930 | BELOW RADIATOR SOUND INSULATION |
| * | 1 | 8044931 | ABOVE RADIATOR SOUND INSULATION |
| 5 | 1 | 8043924 | PANEL SIDE VERTICAL |
| * | 1 | 8044304 | SIDE VERTICAL SOUND INSULATION |
| 6 | 2 | 8040588 | OFFSET HINGE TYPE "A" |
| 7 | 1 | 8044258 | PANEL DOOR |
| * | 1 | 8044309 | DOOR SOUND INSULATION |
| 8 | 1 | 8047102 | 73HS MAIN PLATE WELDMENT |
| 9 | 1 | 8044250 | PANEL TOP WELDMENT |
| 10 | 1 | 8044252 | PANEL REAR |
| * | 1 | 8044306 | LS REAR SOUND INSULATION |
| * | 1 | 8044947 | RS REAR SOUND INSULATION |
| 11 | 1 | 8044262 | PANEL SIDE LOWER GAUGES |
| * | 1 | 8044307 | SIDE LOWER INSULATION |
| 12 | 1 | 8044254 | PANEL SIDE LOWER |
| * | 1 | 8044307 | SIDE LOWER INSULATION |
| 13 | 1 | 8044260 | PANEL DOOR W/TRANS. BOX 73HS |
| * | 1 | 8044310 | DOOR SOUND INSULATION |
| 14 | 2 | 8040586 | SEALED LEVER LATCH |
| | 1 | 8041816 | KEY DOOR SOUTHCO LATCH |
| 15 | 1 | E250210 | BOX, PLASTIC FOR SAFETY MANUAL |
| 16 | 2 | 8040589 | OFFSET HINGE TYPE "B" |
| 17 | 2 | 8044257 | PANEL SIDE UPPER 73HS |
| * | 2 | 8044308 | SIDE UPPER SOUND INSULATION |
| 18 | 1 | 8044283 | EXHAUST SHIELD |
| 19 | 1 | 8043917 | PANEL SIDE VERTICAL CTRL 49VK |
| * | 1 | 8044303 | SIDE VERTICAL CONTROL PANEL SOUND INSULATION |
| * | 1 | 8044223 | EXHAUST FLANGE |
| * | 1 | 8048909 | EXHAUST INSULATION |

* NOT SHOWN

Enclosure Assembly

99AW

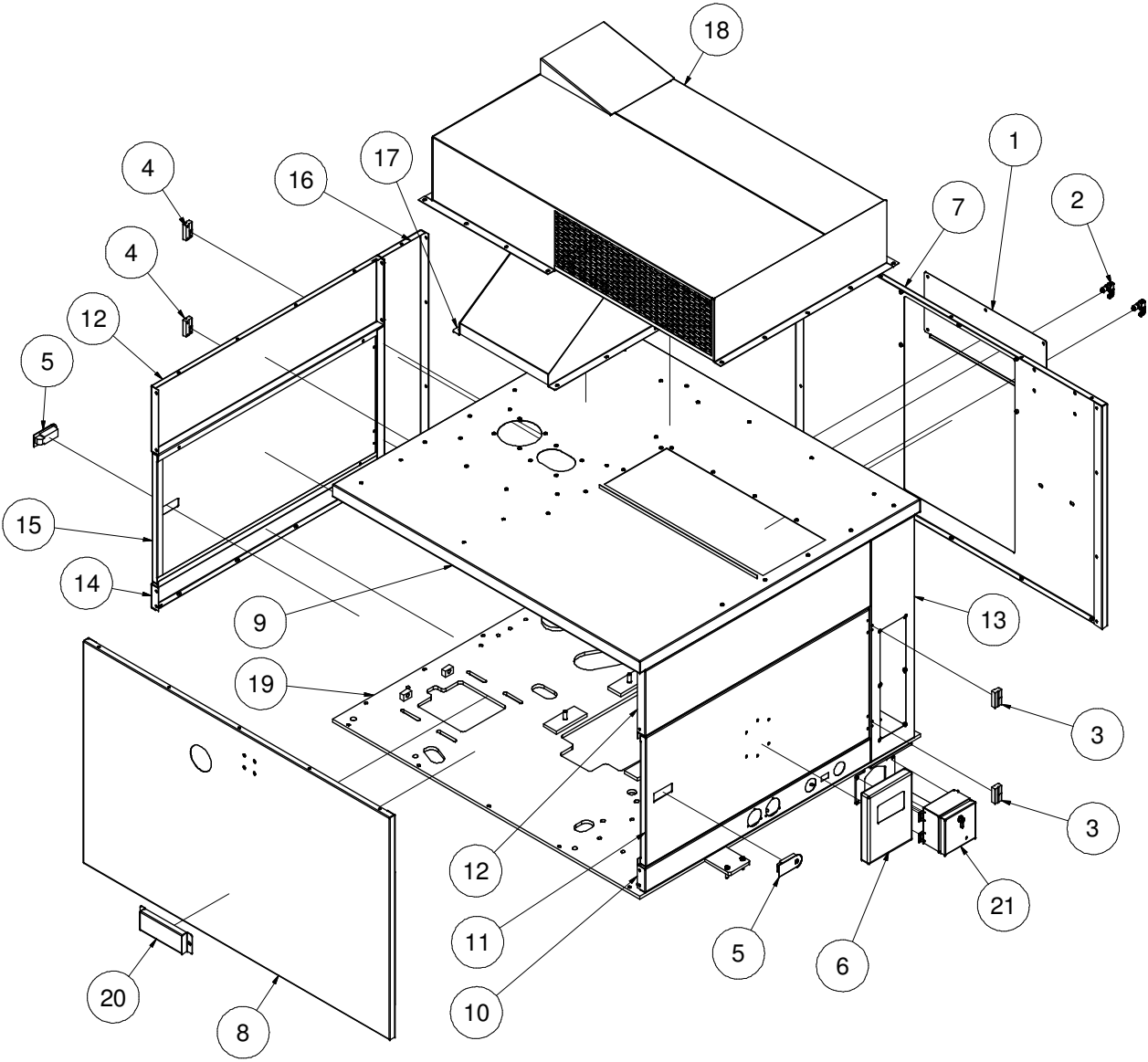

050313-E

VACASSY420

Enclosure Assembly

99AW

| ITEM | QTY | PART # | DESCRIPTION |
|------|-----|---------|---|
| 1 | 1 | 8048431 | ENCLOSURE ACCESS COVER PANEL |
| 2 | 2 | 8040334 | SWELL LATCH |
| | 2 | U120147 | NUT, FLANGED LOCK 5/16"-24 |
| 3 | 2 | 8040588 | OFFSET HINGE TYPE B |
| | 8 | U010010 | SCREW, HSH #10-32 X 3/8" |
| 4 | 2 | 8040589 | OFFSET HINGE TYPE A |
| | 8 | U010010 | SCREW, HSH #10-32 X 3/8" |
| 5 | 2 | 8040586 | SEALED LEVER LATCH |
| | 1 | 8041816 | KEY DOOR SOUTHCO LATCH |
| 6 | 1 | E250210 | MANUAL BOX |
| 7 | 1 | 8044551 | 87HS - PANEL FRONT |
| | 1 | 8044301 | 73HP SOUND INSULATION FRONT LEFT HAND |
| | 1 | 8044302 | 73HP SOUND INSULATION FRONT RIGHT HAND |
| | 1 | 8044930 | 73HP SOUND INSULATION BELOW RADIATOR |
| | 1 | 8044931 | 73HP SOUND INSULATION ABOVE RADIATOR |
| 8 | 1 | 8044252 | 73HS PANEL REAR WELDMENT |
| | 1 | 8044306 | 73HP SOUND INSULATION BACK RS |
| | 1 | 8044947 | 73HP SOUND INSULATION BACK LS |
| 9 | 1 | 8046893 | PANEL TOP 99AW WELDMENT |
| 10 | 1 | 8044256 | 87HS PANEL SIDE LWR GAUAGES WELDMENT (AIR WATER) |
| | 1 | 8044307 | 73HP SOUND INSULATION UNDER DOOR |
| 11 | 1 | 8044260 | 73HS SOUND INSULATION W/ TRANSMITTER MOUNT WELDMENT |
| | 1 | 8044310 | 73HP SOUND INSULATION RH DOOR |
| 12 | 2 | 8044257 | 73HS PANEL SIDE UPPER |
| | 2 | 8044308 | 73HP SOUND INSULATION ABOVE DOOR |
| 13 | 1 | 8043614 | 49VK VERTICAL CONTROL WELDMENT |
| | 1 | 8044303 | 73HP SOUND INSULATION CONTROL PANEL |
| 14 | 1 | 8044254 | 73HS PANEL SIDE LOWER WELDMENT |
| | 1 | 8044307 | 73HP SOUND INSULATION UNDER DOOR |
| 15 | 1 | 8044258 | 73HS PANEL SIDE DOOR |
| | 1 | 8044309 | 73HP SOUND INSULATION LH DOOR |
| 16 | 1 | 8043922 | 49VK PANEL SIDE VERTICAL BLANK WELDMENT |
| | 1 | 8044304 | 73HP SOUND INSULATION OPP. CONTROL PANEL |
| 17 | 1 | 8044283 | EXHAUST SHIELD |
| 18 | 1 | 8048983 | INLET OUTLET BOX |
| 19 | 1 | 8047282 | MAIN PLATE 99AW LE - WELDMENT |
| 20 | 1 | 8046716 | PANEL GUARD ENGINE SHAFT 99AWJ |
| 21 | 1 | 8049096 | ENCLOSURE GAUGE BOX AW |
| | 1 | 8045133 | GAUGE, AIR PRESSURE |
| | 1 | 8045132 | GAUGE, OIL TEMP |
| * | 20 | U000060 | SCREW,HC 1/4-20X1 |
| * | 36 | U000020 | SCREW,HC 1/4-20X1/2 |
| * | 112 | U200020 | WASHER,FLAT 1/4 |
| * | 36 | U120100 | NUT,HEX LOCK 1/4 |
| * | 1 | 8041171 | HANDLE |
| | 2 | U001017 | SCREW, HSH 1/4-20X1.25 |
| | 2 | U200020 | WASHER,FLAT 1/4 |
| | 2 | U120100 | NUT,HEX LOCK 1/4-20 |
| * | 2 | 8041483 | DOOR SEAL VERTICAL |
| * | 1 | 8044223 | ENCLOSURE EXHAUST FLANGE |
| * | 1 | 8048909 | EXHAUST INSULATION |

* NOT SHOWN

050313-E

VACASSY420

Enclosure Assembly

99AW RC

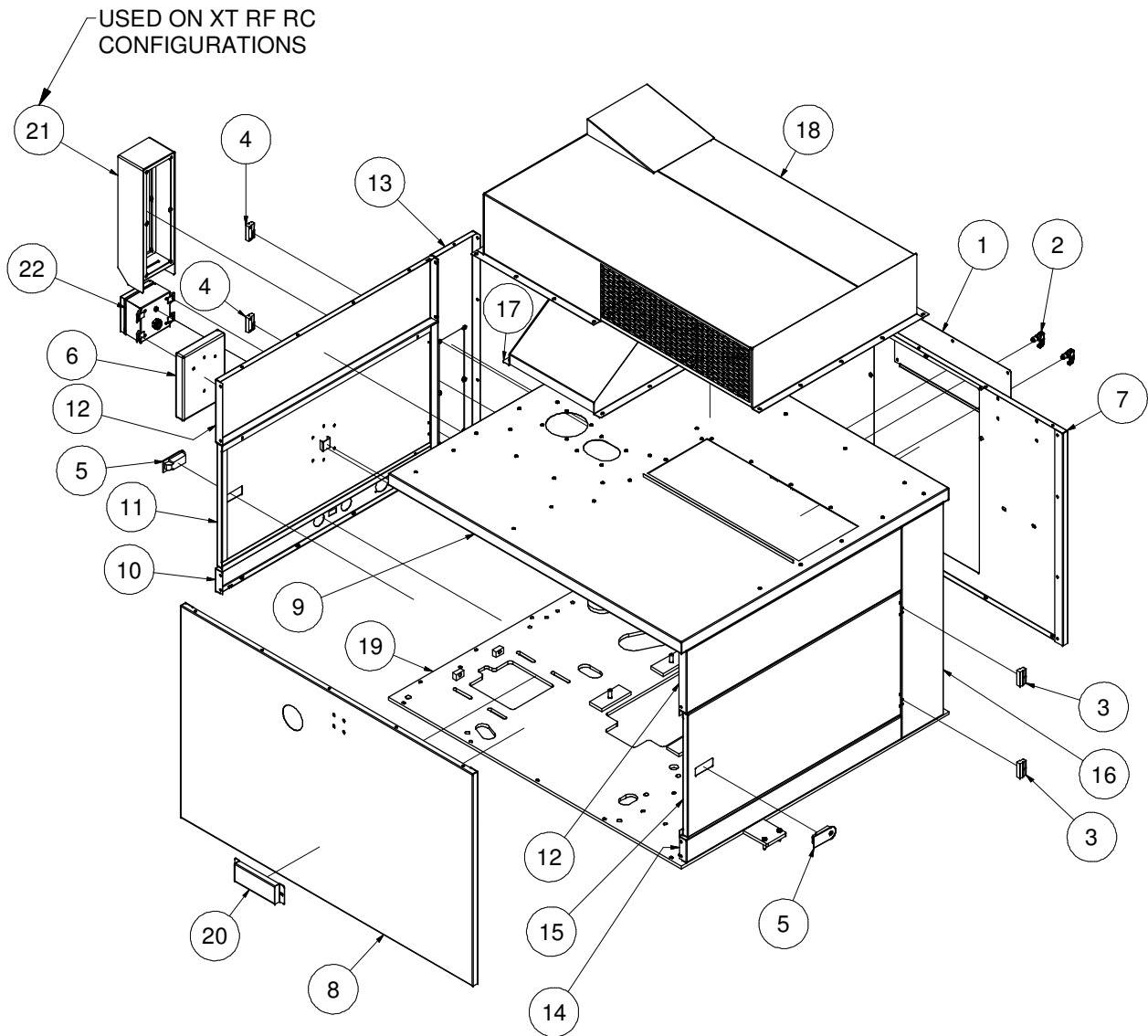

050313-E

VACASSY421

Enclosure Assembly

99AW RC

| ITEM | QTY | PART # | DESCRIPTION |
|------|-----|---------|---|
| 1 | 1 | 8048431 | ENCLOSURE ACCESS COVER PANEL |
| 2 | 2 | 8040334 | SWELL LATCH |
| | 2 | U120147 | NUT, FLANGED LOCK 5/16"-24 |
| 3 | 2 | 8040588 | OFFSET HINGE TYPE B |
| | 8 | U010010 | SCREW, HSH #10-32 X 3/8" |
| 4 | 2 | 8040589 | OFFSET HINGE TYPE A |
| | 8 | U010010 | SCREW, HSH #10-32 X 3/8" |
| 5 | 2 | 8040586 | SEALED LEVER LATCH |
| | 1 | 8041816 | KEY DOOR SOUTHCO LATCH |
| 6 | 1 | E250210 | MANUAL BOX |
| 7 | 1 | 8044551 | 87HS - PANEL FRONT |
| | 1 | 8044301 | 73HP SOUND INSULATION FRONT LEFT HAND |
| | 1 | 8044302 | 73HP SOUND INSULATION FRONT RIGHT HAND |
| | 1 | 8044930 | 73HP SOUND INSULATION BELOW RADIATOR |
| | 1 | 8044931 | 73HP SOUND INSULATION ABOVE RADIATOR |
| 8 | 1 | 8044252 | 73HS PANEL REAR WELDMENT |
| | 1 | 8044306 | 73HP SOUND INSULATION BACK RS |
| | 1 | 8044947 | 73HP SOUND INSULATION BACK LS |
| 9 | 1 | 8046893 | PANEL TOP 99AW WELDMENT |
| 10 | 1 | 8044256 | 87HS PANEL SIDE LWR GAUAGES WELDMENT (AIR WATER) |
| | 1 | 8044307 | 73HP SOUND INSULATION UNDER DOOR |
| 11 | 1 | 8044260 | 73HS SOUND INSULATION W/ TRANSMITTER MOUNT WELDMENT |
| | 1 | 8044310 | 73HP SOUND INSULATION RH DOOR |
| 12 | 2 | 8044257 | 73HS PANEL SIDE UPPER |
| | 2 | 8044308 | 73HP SOUND INSULATION ABOVE DOOR |
| 13 | 1 | 8043614 | 49VK VERTICAL CONTROL WELDMENT |
| | 1 | 8044303 | 73HP SOUND INSULATION CONTROL PANEL |
| 14 | 1 | 8044254 | 73HS PANEL SIDE LOWER WELDMENT |
| | 1 | 8044307 | 73HP SOUND INSULATION UNDER DOOR |
| 15 | 1 | 8044258 | 73HS PANEL SIDE DOOR |
| | 1 | 8044309 | 73HP SOUND INSULATION LH DOOR |
| 16 | 1 | 8043922 | 49VK PANEL SIDE VERTICAL BLANK WELDMENT |
| | 1 | 8044304 | 73HP SOUND INSULATION OPP. CONTROL PANEL |
| 17 | 1 | 8044283 | EXHAUST SHIELD |
| 18 | 1 | 8048983 | INLET OUTLET BOX |
| 19 | 1 | 8047282 | MAIN PLATE 99AW LE - WELDMENT |
| 20 | 1 | 8046716 | PANEL GUARD ENGINE SHAFT 99AWJ |
| 21 | 1 | 8048170 | PANEL U-EXTENSION |
| 22 | 1 | 8049096 | ENCLOSURE GAUGE BOX AW |
| | 1 | 8045133 | GAUGE, AIR PRESSURE |
| | 1 | 8045132 | GAUGE, OIL TEMP |
| * | 20 | U000060 | SCREW,HC 1/4-20X1 |
| * | 36 | U000020 | SCREW,HC 1/4-20X1/2 |
| * | 112 | U200020 | WASHER,FLAT 1/4 |
| * | 36 | U120100 | NUT,HEX LOCK 1/4 |
| * | 1 | 8041171 | HANDLE |
| | 2 | U001017 | SCREW,HSH 1/4-20X1.25 |
| | 2 | U200020 | WASHER,FLAT 1/4 |
| | 2 | U120100 | NUT,HEX LOCK 1/4-20 |
| * | 2 | 8041483 | DOOR SEAL VERTICAL |
| * | 1 | 8048909 | EXHAUST INSULATION |
| * | 1 | 8044223 | EXHAUST INSULATION FLANGE |

* NOT SHOWN

050313-E

VACASSY421

Engine Kubota V3600

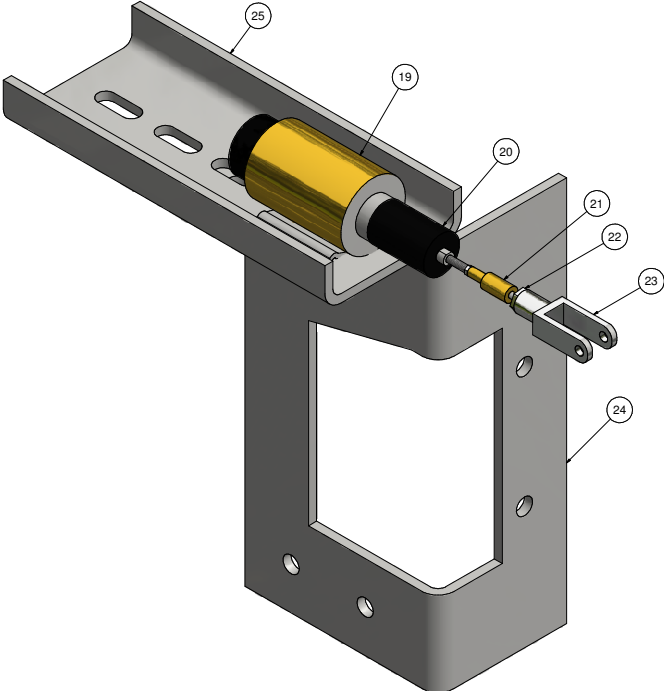
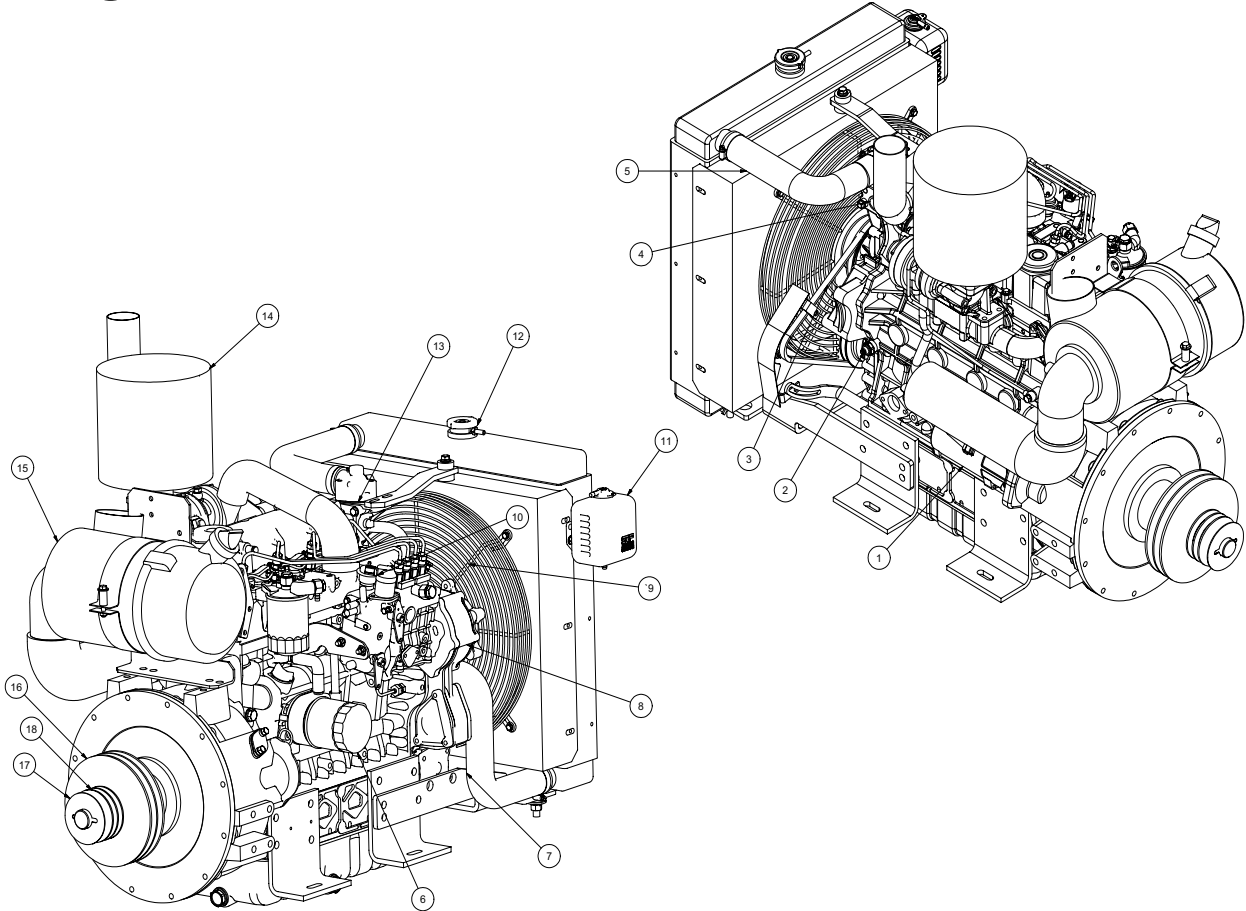

021913-E

VACASSY852

Engine Kubota V3600

| ITEM | QTY | NUMBER | DESCRIPTION |
|------|-----|------------|---|
| | 1 | 8047103 | ENGINE |
| 1 | 1 | 8045583 | STARTER |
| 2 | 1 | 8030960 | OIL PRESSURE SWITCH |
| 3 | 1 | 8045584 | FAN BELT |
| 4 | 1 | 8043952 | WATER TEMPERTURE SWITCH |
| 5 | 1 | 8045585 | UPPER RADIATOR HOSE |
| 6 | 1 | 8032002 | OIL FILTER |
| 7 | 1 | 8045586 | LOWER RADIATOR HOSE |
| 8 | 1 | 8045587 | ALTERNATOR |
| 9 | 1 | 8045588 | FAN |
| 10 | 1 | 8045589 | FUEL SHUTOFF SOLENOID |
| 11 | 1 | 8045590 | OVERFLOW TANK |
| | | | OVERFLOW TANK CAP (Sold With Tank) |
| 12 | 1 | 8045591 | RADIATOR CAP |
| 13 | 1 | 8045592 | THERMOSTAT |
| 14 | 1 | 8045593 | MUFFLER |
| 15 | 1 | 8045594 | AIR FILTER HOUSING |
| * | 1 | 8041055 | AIR FILTER ELEMENT (INNER) |
| * | 1 | 8041054 | AIR FILTER ELEMENT (OUTER) |
| 16 | 1 | 8044243 | SHEAVE, BLOWER 8.35" OD 2517 TL |
| | 1 | 8042659 | BUSHING, TL2517 1 7/16" |
| 17 | 1 | 8041799 | KEYWAY RETAINER |
| 18 | 1 | 8040480 | SHEAVE, WATERPUMP 4.15"OD SH 2-GROOVE |
| | 1 | 8040481 | BUSHING, 1 7/16" SH |
| * | 1 | 8041053 | FUEL FILTER |
| * | 1 | 8045595 | FUEL PUMP |
| * | 1 | T400106 | RADIATOR DRAIN FITTING |
| * | 1 | 8047108 | BRACKET, WATER SEPARATOR |
| * | 1 | 8047265 | OIL / WATER SEPARATOR |
| 19 | 1 | 8030667 | THROTTLE SOLENOID |
| 20 | 1 | 8030667-1 | RETURN SPRING |
| 21 | 1 | 8046052 | THROTTLE SOLENOID SPRING SWIVEL |
| 22 | 2 | 8030667-5 | JAM NUT |
| 23 | 1 | 8030667-3 | CLEVIS (INCLUDES PIN AND COTTER PIN) |
| 24 | 1 | 8030667-11 | THROTTLE SOLENOID BRACKET (VERTICAL) |
| 25 | 1 | 8030667-10 | THROTTLE SOLENOID BRACKET |
| * | 1 | X300299 | CABLE BATTERY KIT 67-99HP WITH ELECT. HYD. PUMP |

* Not Shown

Engine Kubota V3600

Boom/ Aux. Hyd.

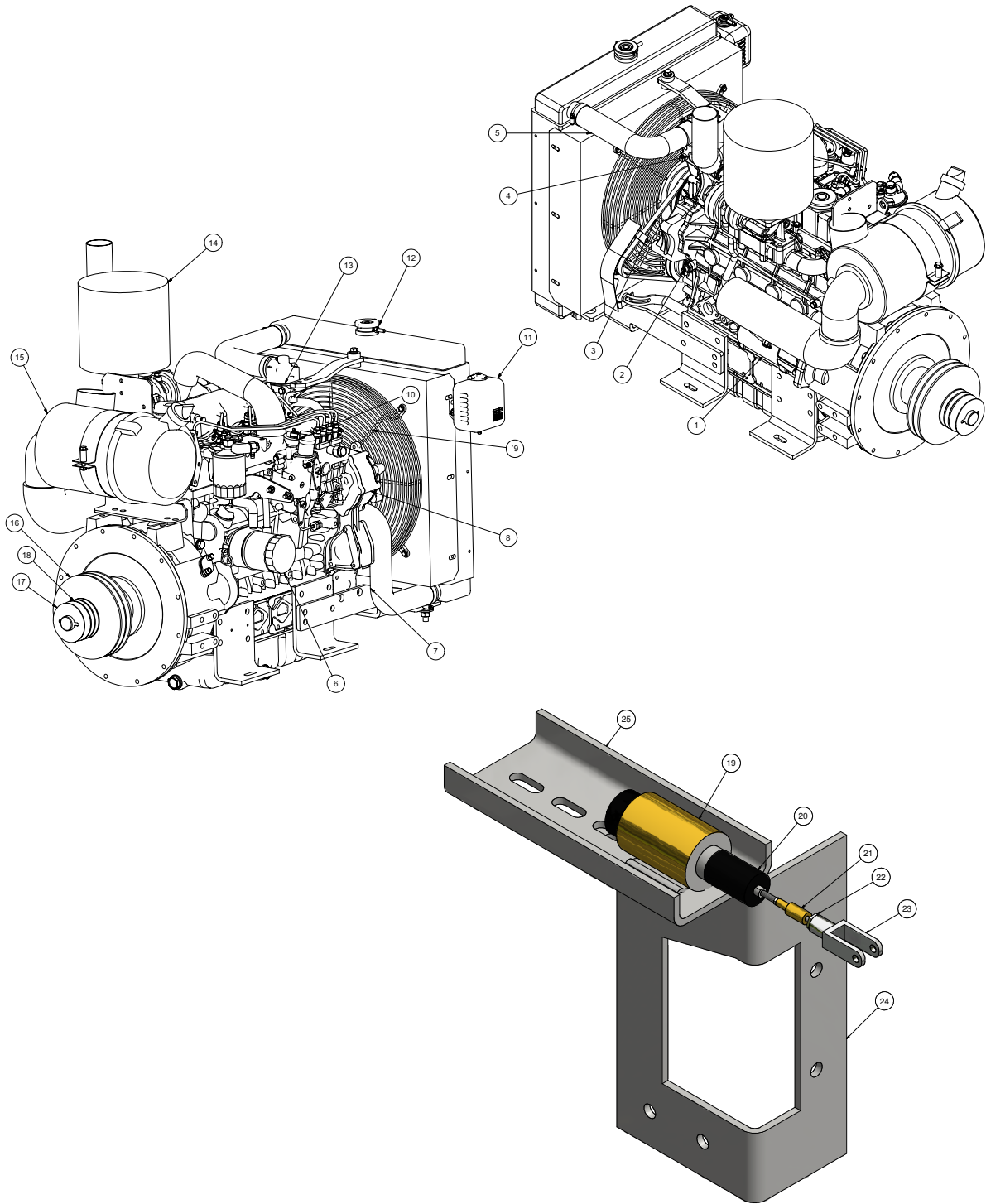

022113-E

VACASSY01802

Engine Kubota V3600

Boom/ Aux. Hyd.

| ITEM | QTY | NUMBER | DESCRIPTION |
|------|-----|------------|--|
| | 1 | 8047103 | ENGINE |
| 1 | 1 | 8045583 | STARTER |
| 2 | 1 | 8030960 | OIL PRESSURE SWITCH |
| 3 | 1 | 8045584 | FAN BELT |
| 4 | 1 | 8043952 | WATER TEMPERTURE SWITCH |
| 5 | 1 | 8045585 | UPPER RADIATOR HOSE |
| 6 | 1 | 8032002 | OIL FILTER |
| 7 | 1 | 8045586 | LOWER RADIATOR HOSE |
| 8 | 1 | 8045587 | ALTERNATOR |
| 9 | 1 | 8045588 | FAN |
| 10 | 1 | 8045589 | FUEL SHUTOFF SOLENOID |
| 11 | 1 | 8045590 | OVERFLOW TANK |
| | | | OVERFLOW TANK CAP (Sold With Tank) |
| 12 | 1 | 8045591 | RADIATOR CAP |
| 13 | 1 | 8045592 | THERMOSTAT |
| 14 | 1 | 8045593 | MUFFLER |
| 15 | 1 | 8045594 | AIR FILTER HOUSING |
| * | 1 | 8041055 | AIR FILTER ELEMENT (INNER) |
| * | 1 | 8041054 | AIR FILTER ELEMENT (OUTER) |
| 16 | 1 | 8044243 | SHEAVE, BLOWER 8.35" OD 2517 TL |
| | 1 | 8042659 | BUSHING, TL2517 1 7/16" |
| 17 | 1 | 8041799 | KEYWAY RETAINER |
| 18 | 1 | 8040480 | SHEAVE, WATERPUMP 4.15" OD SH 2-GROOVE |
| | 1 | 8040481 | BUSHING, 1 7/16" SH |
| * | 1 | 8041053 | FUEL FILTER |
| * | 1 | 8045595 | FUEL PUMP |
| * | 1 | T400106 | RADIATOR DRAIN FITTING |
| * | 1 | 8047108 | BRACKET, WATER SEPARATOR |
| * | 1 | 8047265 | OIL / WATER SEPARATOR |
| 19 | 1 | 8030667 | THROTTLE SOLENOID |
| 20 | 1 | 8030667-1 | RETURN SPRING |
| 21 | 1 | 8046052 | THROTTLE SOLENOID SPRING SWIVEL |
| 22 | 2 | 8030667-5 | JAM NUT |
| 23 | 1 | 8030667-3 | CLEVIS (INCLUDES PIN AND COTTER PIN) |
| 24 | 1 | 8030667-11 | THROTTLE SOLENOID BRACKET (VERTICAL) |
| 25 | 1 | 8030667-10 | THROTTLE SOLENOID BRACKET |
| * | 1 | X300296 | CABLE BATTERY KIT 67-99HP WITH NO ELECT. HYD. PUMP |

* Not Shown

Engine Kubota V3800T

99HP

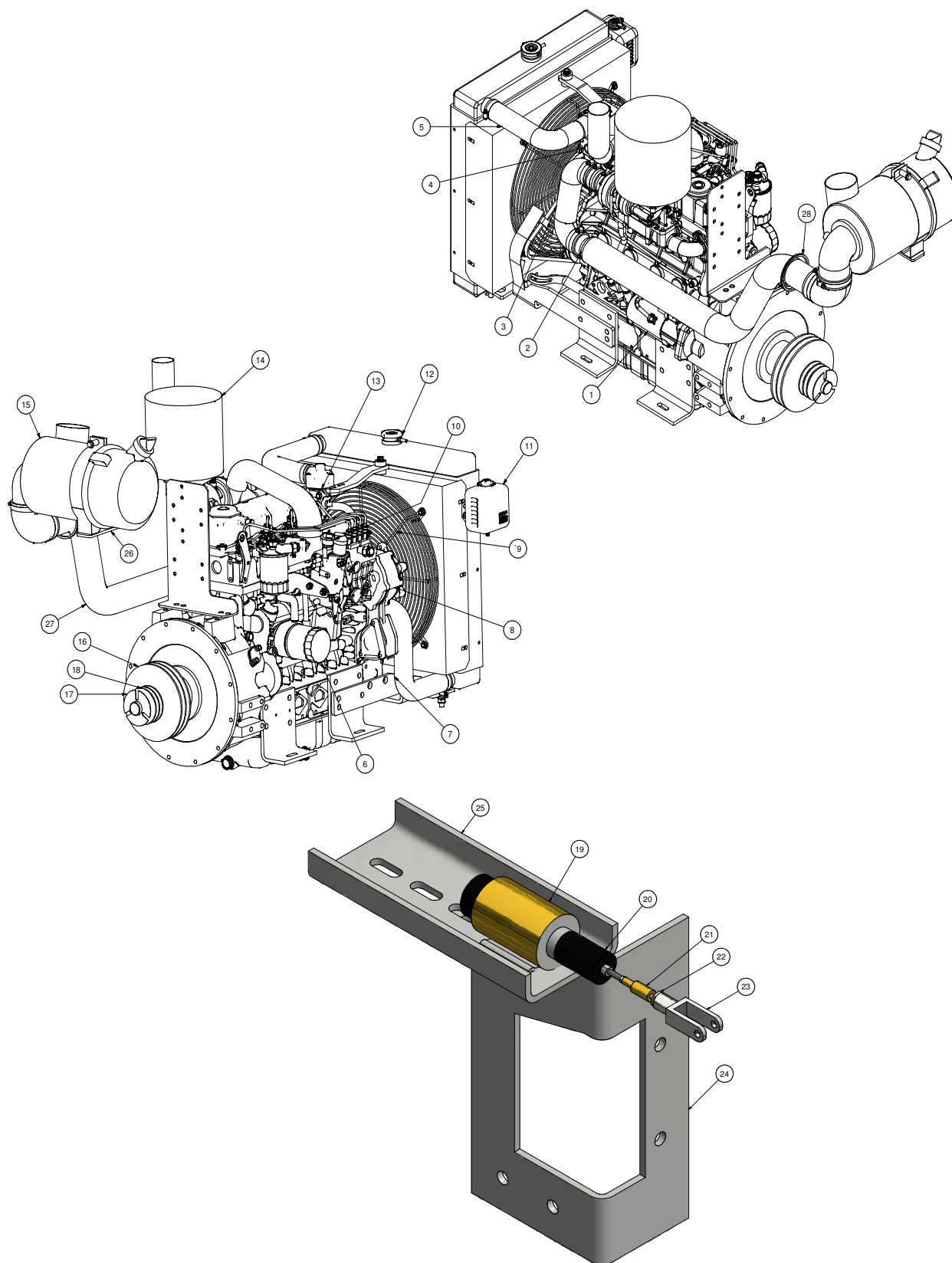

020113-E

VACASSY849

Engine Kubota V3800T

99HP

| ITEM | QTY | NUMBER | DESCRIPTION |
|--------------------------|-----|------------|---|
| | 1 | 8045154 | ENG, KUBOTA 99HP (Short SAE4 HSG) |
| 1 | 1 | 8046034 | STARTER |
| 2 | 1 | 8030960 | OIL PRESSURE SWITCH |
| 3 | 1 | 8046035 | FAN BELT |
| 4 | 1 | 8043952 | WATER TEMPATURE SWITCH |
| 5 | 1 | 8045585 | UPPER RADIATOR HOSE |
| 6 | 1 | 8032002 | OIL FILTER |
| 7 | 1 | 8045586 | LOWER RADIATOR HOSE |
| 8 | 1 | 8046036 | ALTERNATOR |
| 9 | 1 | 8045588 | FAN |
| 10 | 1 | 8045589 | FUEL SHUTOFF SOLENOID |
| 11 | 1 | 8045590 | OVERFLOW TANK |
| | | | OVERFLOW TANK CAP (Sold With Tank) |
| 12 | 1 | 8045591 | RADIATOR CAP |
| 13 | 1 | 8045592 | THERMOSTAT |
| 14 | 1 | 8044485 | MUFFLER |
| 15 | 1 | 8045594 | AIR FILTER HOUSING |
| * | 1 | 8041055 | AIR FILTER ELEMENT (INNER) |
| * | 1 | 8041054 | AIR FILTER ELEMENT (OUTER) |
| 16 | 1 | 8044243 | SHEAVE, BLOWER 8.35"OD 2517 TL |
| | 1 | 8042659 | BUSHING, TL2517 1 7/16" |
| 17 | 1 | 8041799 | KEYWAY RETAINER |
| 18 | 1 | 8044244 | SHEAVE, WATERPUMP 3.95" OD QT 2-GROOVE |
| | 1 | 8044245 | BUSHING, 1 7/16" QT |
| * | 1 | 8041053 | FUEL FILTER |
| * | 1 | 8045595 | FUEL PUMP |
| * | 1 | T400106 | RADIATOR DRAIN FITTING |
| * | 1 | 8047370 | BRACKET, WATER SEPARATOR |
| * | 1 | 8047266 | OIL / WATER SSEPARATOR |
| 19 | 1 | 8030667-10 | THROTTLE SOLENOID BRACKET |
| 20 | 1 | 8030667 | THROTTLE SOLENOID |
| 21 | 1 | 8030667-1 | RETURN SPRING |
| 22 | 1 | 8046052 | THROTTLE SOLENOID SPRING SWIVEL |
| 23 | 2 | 8030667-5 | JAM NUT |
| 24 | 1 | 8030667-3 | CLEVIS (INCLUDES PIN AND COTTER PIN) |
| 25 | 1 | 8030667-11 | THROTTLE SOLENOID BRACKET (VERTICAL) |
| 26 | 1 | 8048024 | AIR CLEANER RELOCATION MOUNTING PLATE |
| | 4 | U000420 | SCREW, HC .375-16 X 1.00 ZP G5 |
| | 4 | U120110 | NUT, LOCK 3/8-16NY |
| | 4 | U200060 | WASHER, FLAT .375 ZP |
| | 4 | U210060 | WASHER, LOCK .375 ZP |
| 27 | 1 | 8048486 | AIR CLEANER INTAKE 99HP |
| 28 | 1 | 8048266 | EDGE GUARD, 67/99HP RELOCATION |
| * | 1 | X300299 | CABLE BATTERY KIT 67-99HP WITH ELECT. HYD. PUMP |
| OPTION FOR JETTER | | | |
| * | 1 | 8046698 | GREASE BOLT SPACER |
| * | 1 | 8046699 | GREASE BOLT |

* Not Shown

Engine Kubota V3800T

Boom/ Aux. Hyd.

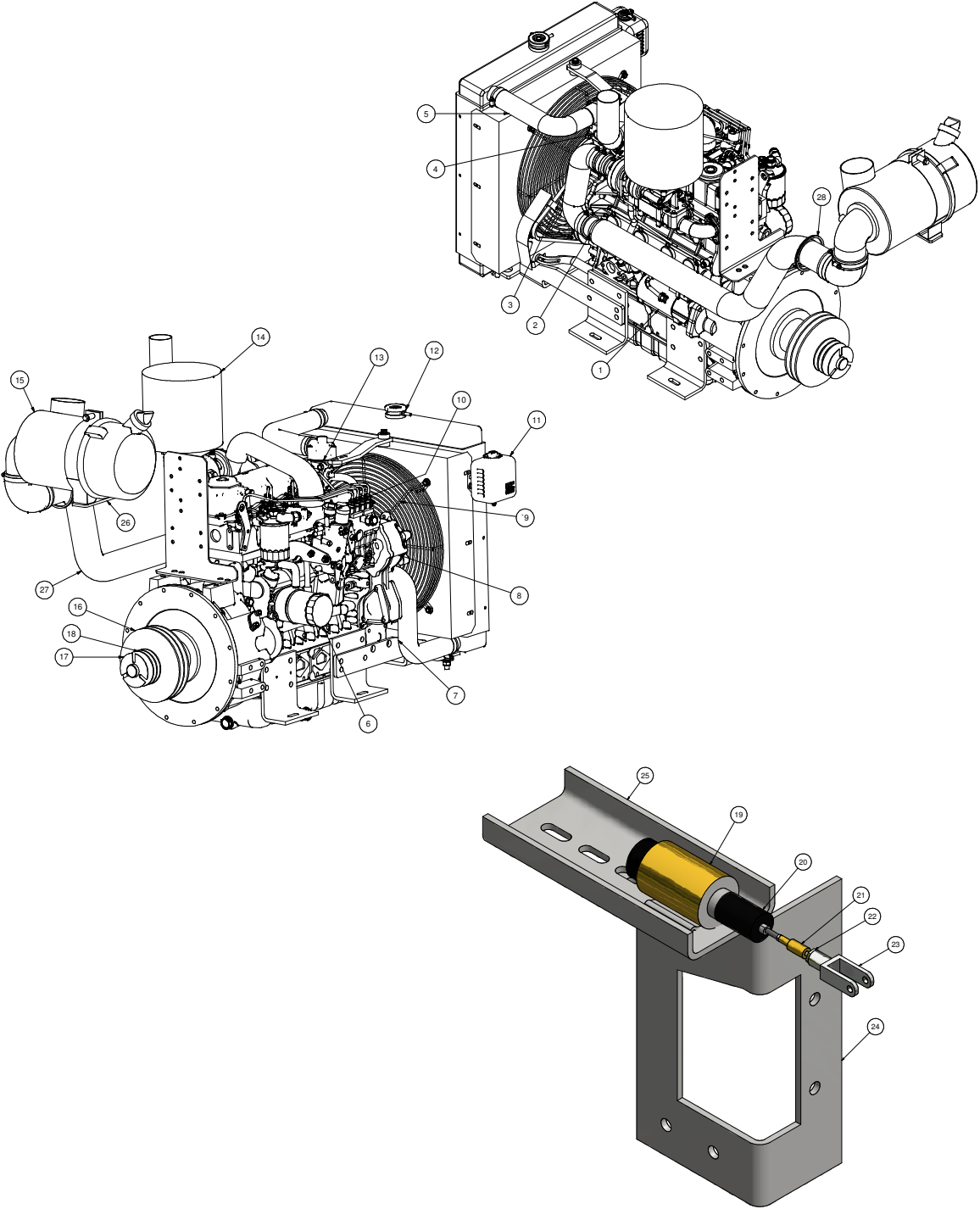

020113-E

VACASSY01803

Engine Kubota V3800T

Boom/ Aux. Hyd.

| ITEM | QTY | NUMBER | DESCRIPTION |
|--------------------------|-----|------------|--|
| | 1 | 8045154 | ENG, KUBOTA 99HP (Short SAE4 HSG) |
| 1 | 1 | 8046034 | STARTER |
| 2 | 1 | 8030960 | OIL PRESSURE SWITCH |
| 3 | 1 | 8046035 | FAN BELT |
| 4 | 1 | 8043952 | WATER TEMPERTURE SWITCH |
| 5 | 1 | 8045585 | UPPER RADIATOR HOSE |
| 6 | 1 | 8032002 | OIL FILTER |
| 7 | 1 | 8045586 | LOWER RADIATOR HOSE |
| 8 | 1 | 8046036 | ALTERNATOR |
| 9 | 1 | 8045588 | FAN |
| 10 | 1 | 8045589 | FUEL SHUTOFF SOLENOID |
| 11 | 1 | 8045590 | OVERFLOW TANK |
| | | | OVERFLOW TANK CAP (Sold With Tank) |
| 12 | 1 | 8045591 | RADIATOR CAP |
| 13 | 1 | 8045592 | THERMOSTAT |
| 14 | 1 | 8044485 | MUFFLER |
| 15 | 1 | 8045594 | AIR FILTER HOUSING |
| * | 1 | 8041055 | AIR FILTER ELEMENT (INNER) |
| * | 1 | 8041054 | AIR FILTER ELEMENT (OUTER) |
| 16 | 1 | 8044243 | SHEAVE, BLOWER 8.35"OD 2517 TL |
| | 1 | 8042659 | BUSHING, TL2517 1 7/16" |
| 17 | 1 | 8041799 | KEYWAY RETAINER |
| 18 | 1 | 8044244 | SHEAVE, WATERPUMP 3.95" OD QT 2-GROOVE |
| | 1 | 8044245 | BUSHING, 1 7/16" QT |
| * | 1 | 8041053 | FUEL FILTER |
| * | 1 | 8045595 | FUEL PUMP |
| * | 1 | T400106 | RADIATOR DRAIN FITTING |
| * | 1 | 8047370 | BRACKET, WATER SEPARATOR |
| * | 1 | 8047266 | OIL / WATER SSEPARATOR |
| 19 | 1 | 8030667-10 | THROTTLE SOLENOID BRACKET |
| 20 | 1 | 8030667 | THROTTLE SOLENOID |
| 21 | 1 | 8030667-1 | RETURN SPRING |
| 22 | 1 | 8046052 | THROTTLE SOLENOID SPRING SWIVEL |
| 23 | 2 | 8030667-5 | JAM NUT |
| 24 | 1 | 8030667-3 | CLEVIS (INCLUDES PIN AND COTTER PIN) |
| 25 | 1 | 8030667-11 | THROTTLE SOLENOID BRACKET (VERTICAL) |
| 26 | 1 | 8048024 | AIR CLEANER RELOCATION MOUNTING PLATE |
| | 4 | U000420 | SCREW, HC .375-16 X 1.00 ZP G5 |
| | 4 | U120110 | NUT, LOCK 3/8-16NY |
| | 4 | U200060 | WASHER, FLAT .375 ZP |
| | 4 | U210060 | WASHER, LOCK .375 ZP |
| 27 | 1 | 8048486 | AIR CLEANER INTAKE 99HP |
| 28 | 1 | 8048266 | EDGE GUARD, 67/99HP RELOCATION |
| * | 1 | X300296 | CABLE BATTERY KIT 67-99HP WITH NO ELECT. HYD. PUMP |
| OPTION FOR JETTER | | | |
| * | 1 | 8046698 | GREASE BOLT SPACER |
| * | 1 | 8046699 | GREASE BOLT |

* Not Shown

Blower Assembly

67HD

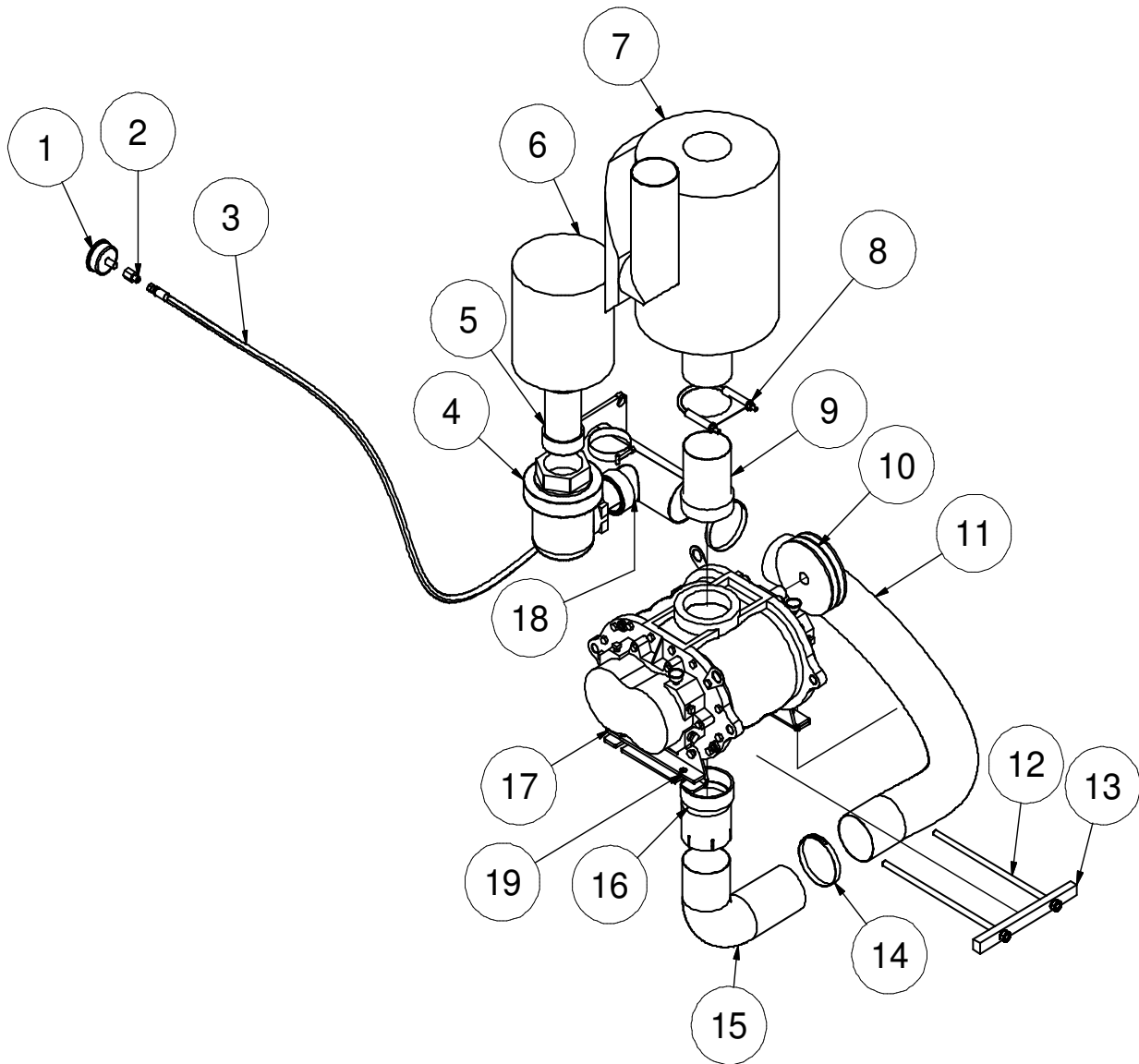

040513-E

VACASSY01204

Blower Assembly

67HD

| ITEM | QTY | NUMBER | DESCRIPTION |
|------|-----|---------|--------------------------------|
| 1 | 1 | 8041074 | GAUGE COMPOUND PRESSURE/VACUUM |
| 2 | 1 | T400110 | UNION, 4FP - 4MJ |
| 3 | 1 | 8042355 | HOSE ASSY VAC 4-60" ST-ST |
| 4 | 1 | 8030866 | BAYCO VALVE |
| 5 | 1 | 8045238 | UNION EXHAUST 3" OD-MNPT |
| 6 | 1 | 8043553 | AIR FILTER 3" 245CFM |
| 7 | 1 | 8030917 | SILENCER, 1025CFM, COWL |
| 8 | 1 | 8031193 | CLAMP, 4in U-BOLT EXHAUST |
| 9 | 1 | 8045239 | UNION EXHAUST 4" OD - MNPT |
| 10 | 1 | 8040697 | SHEAVE, 6.55DIA 2 - GROOVE |
| | 1 | 8040485 | BUSHING, 1 1/8" SDS |
| | 1 | U410090 | KEY, 1/4" X 1/4" X 2 3/4" |
| | 2 | 8049162 | BELT, BP57 |
| 11 | 1 | 8046575 | HOSE VAC AG SUCTION 4-51" |
| 12 | 2 | 8041507 | ROD TIGHTENER WELDMENT |
| 13 | 1 | 8040904 | TENSION BLOCK 1025 CFM |
| 14 | 2 | 8042606 | CLAMP T-BOLT 4" (450) |
| 15 | 1 | 8041814 | ELBOW, 4" (4.5" RAD, OD-OD) |
| 16 | 1 | 8046820 | ADAPTER 4"MNPT - 4"ID |
| 17 | 1 | 8040001 | BLOWER (MODEL 59) |
| | 4 | U000817 | SCREW, HC 1/2" - 13 X 1" |
| | 4 | U210100 | WASHER, LOCK 1/2" |
| | 4 | U200100 | WASHER, FLAT 1/2" |
| 18 | 1 | 8046415 | HEADER, AIR FILTER 1025 |
| | 1 | 8046191 | GASKET, HEADER AIR FILTER |
| 19 | 2 | 8045252 | BLOWER BOLT PLATE |

040513-E

VACASSY01204

Blower Assembly

67/99HP 1025CFM

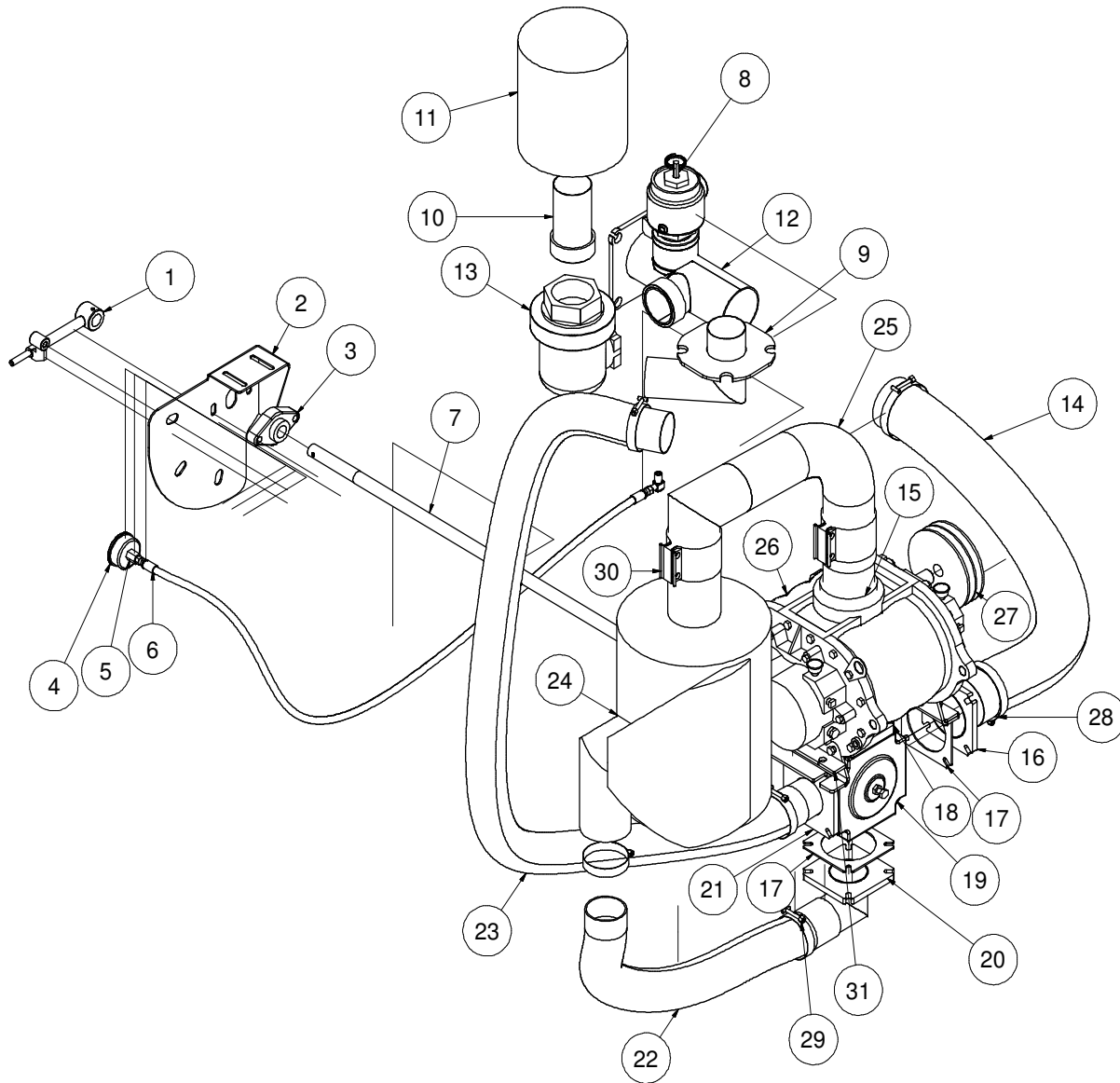

040513-E

VACASSY240

Blower Assembly

67/99HP 1025CFM

| ITEM | QTY | NUMBER | DESCRIPTION |
|------|-----|------------|--|
| 1 | 1 | 8041617 | REVERSE FLOW HANDLE, TRAILER UNIT |
| | 1 | 8041177-10 | HANDLE GRIP |
| 2 | 1 | 8046202 | BRACKET REV FLOW CONTROL LE |
| | 3 | 8048585 | GROMMET, .884/.878 X .266 X .234 |
| 3 | 1 | W030080 | FLANGE BEARING - 2 BOLT (1" BORE) |
| 4 | 1 | 8041074 | GAUGE COMPOUND PRESSURE/VACUUM |
| 5 | 1 | T400110 | UNION 4FP-4MJ |
| 6 | 1 | 8045869 | HOSE ASSY VAC 4-34" ST-ST |
| 7 | 1 | 8048342 | REV FLOW UNIVERSAL JOINT RD SHAFT 49LE |
| 8 | 1 | 8041035 | PRESSURE RELIEF 1025 |
| 9 | 1 | 8046218 | EXHAUST REV FLOW PIPE WELDMENT |
| 10 | 1 | 8045238 | UNION EXHAUST 3" OD-MNPT |
| 11 | 1 | 8043553 | AIR FILTER 3" 245 CFM |
| 12 | 1 | 8048126 | 4" HEADER AIR FILTER HDRF |
| | 1 | 8048127 | HEADER, 4" AIR FILTER V2000/V2200 |
| | 1 | 8048128 | HEADER, 4" AIR FILTER V2600/V3000 |
| | 1 | 8046191 | GASKET, HEADER |
| 13 | 1 | 8030866 | BAYCO VALVE |
| 14 | 1 | 8046575 | HOSE VAC AG SUCTION 4 - 51" |
| 15 | 1 | 8030560 | 4" HOSE COUPLING WELDMENT |
| 16 | 1 | 8046484 | EXHAUST REV FLOW 4" X 4" FLANGE WELDMENT |
| 17 | 4 | 8043554 | ADAPTER VALVE FLANGE |
| 18 | 1 | 8044330 | REV FLOW 4" HEADER NIP ASSY |
| 19 | 1 | 8041177 | 4" 4-WAY VALVE |
| 20 | 1 | 8046201 | ELBOW EXHAUST 3" W/ 4" FLANGE |
| 21 | 1 | 8046222 | EXHAUST REV FLOW 3" X 4" FLANGE WELDMENT |
| 22 | 1 | 8046576 | HOSE VAC AG SUCTION 3 - 29" |
| 23 | 1 | 8046577 | HOSE VAC AG SUCTION 3 - 65" |
| 24 | 1 | 8030917 | SILENCER, 1025 CFM, COWL |
| 25 | 1 | 8046505 | EXHAUST 4" ID-OD W/COUPLING WELDMENT |
| 26 | 1 | 8040001 | BLOWER (MODEL 59) |
| 27 | 1 | 8044515 | SHEAVE 7.75" OD SDS 2-GROOVE |
| | 1 | 8044516 | BUSHING 1 1/8" SD |
| | 2 | 8049162 | BELTS, BP57 |
| | 1 | 8041798 | RETAINER |
| 28 | 2 | 8042606 | CLAMP HOSE T-BOLT 450 |
| 29 | 4 | 8042605 | CLAMP HOSE T-BOLT 350 |
| 30 | 2 | 8030400 | 4" BAND CLAMP |

040513-E

VACASSY240

Blower Assembly

67HD JETTER

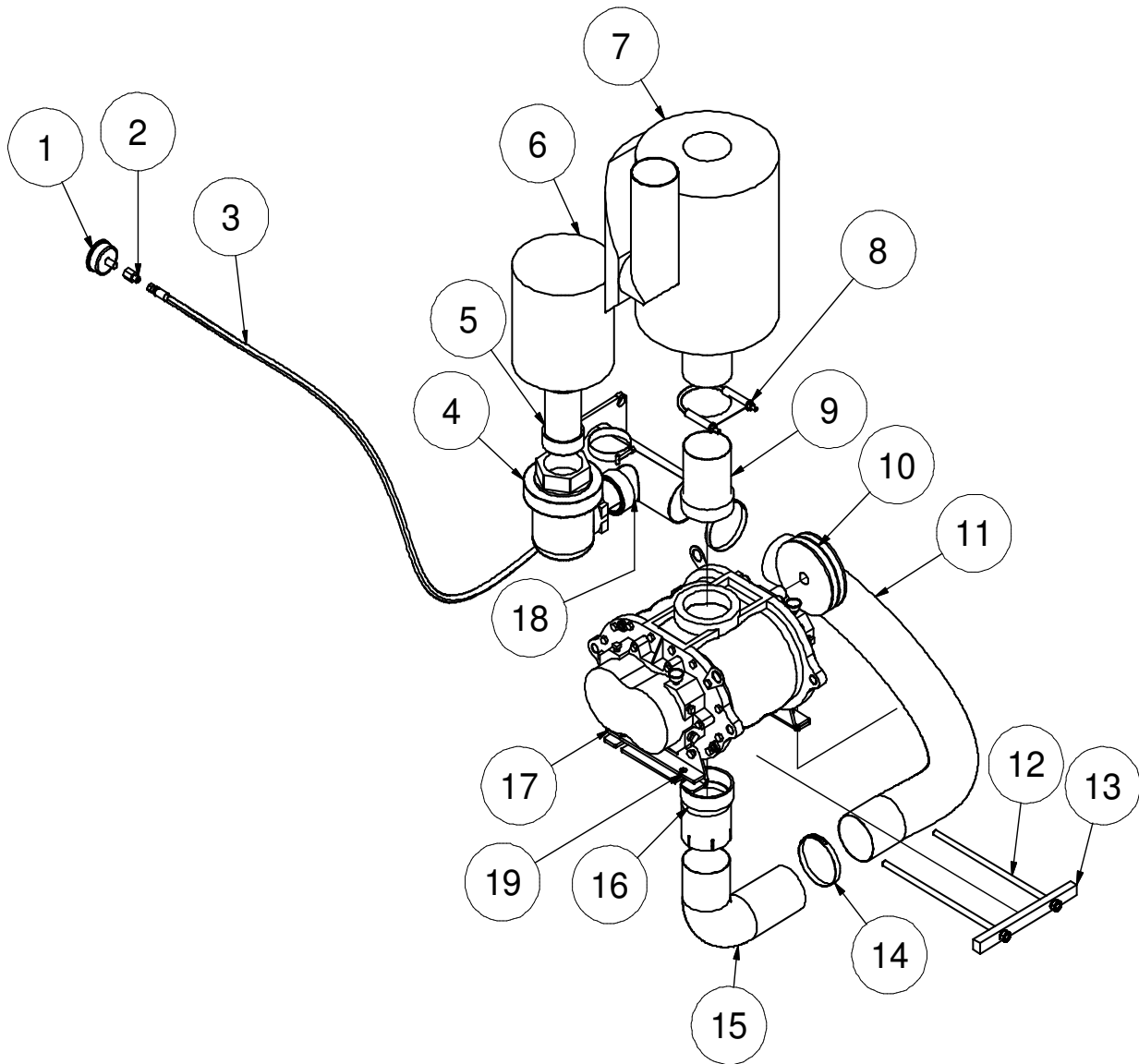

041113-E

VACASSY01205

Blower Assembly

67HD JETTER

| ITEM | QTY | NUMBER | DESCRIPTION |
|------|-----|---------|--------------------------------|
| 1 | 1 | 8041074 | GAUGE COMPOUND PRESSURE/VACUUM |
| 2 | 1 | T400110 | UNION, 4FP - 4MJ |
| 3 | 1 | 8042355 | HOSE ASSY VAC 4-60" ST-ST |
| 4 | 1 | 8030866 | BAYCO VALVE |
| 5 | 1 | 8045238 | UNION EXHAUST 3" OD-MNPT |
| 6 | 1 | 8043553 | AIR FILTER 3" 245CFM |
| 7 | 1 | 8030917 | SILENCER, 1025CFM, COWL |
| 8 | 1 | 8031193 | CLAMP, 4in U-BOLT EXHAUST |
| 9 | 1 | 8045239 | UNION EXHAUST 4" OD - MNPT |
| 10 | 1 | 8040697 | SHEAVE, 6.55DIA 2 - GROOVE |
| | 1 | 8040485 | BUSHING, 1 1/8" SDS |
| | 1 | U410090 | KEY, 1/4" X 1/4" X 2 3/4" |
| | 2 | 8049160 | BELT, BP52 |
| 11 | 1 | 8046575 | HOSE VAC AG SUCTION 4-51" |
| 12 | 2 | 8041507 | ROD TIGHTENER WELDMENT |
| 13 | 1 | 8040904 | TENSION BLOCK 1025 CFM |
| 14 | 2 | 8042606 | CLAMP T-BOLT 4" (450) |
| 15 | 1 | 8041814 | ELBOW, 4" (4.5" RAD, OD-OD) |
| 16 | 1 | 8046820 | ADAPTER 4"MNPT - 4"ID |
| 17 | 1 | 8040001 | BLOWER (MODEL 59) |
| | 4 | U000817 | SCREW, HC 1/2" - 13 X 1" |
| | 4 | U210100 | WASHER, LOCK 1/2" |
| | 4 | U200100 | WASHER, FLAT 1/2" |
| 18 | 1 | 8046415 | HEADER, AIR FILTER 1025 |
| | 1 | 8046191 | GASKET, HEADER AIR FILTER |
| 19 | 2 | 8045252 | BLOWER BOLT PLATE |

041113-E

VACASSY01205

Blower Assembly

67/99HP 1025CFM JETTER

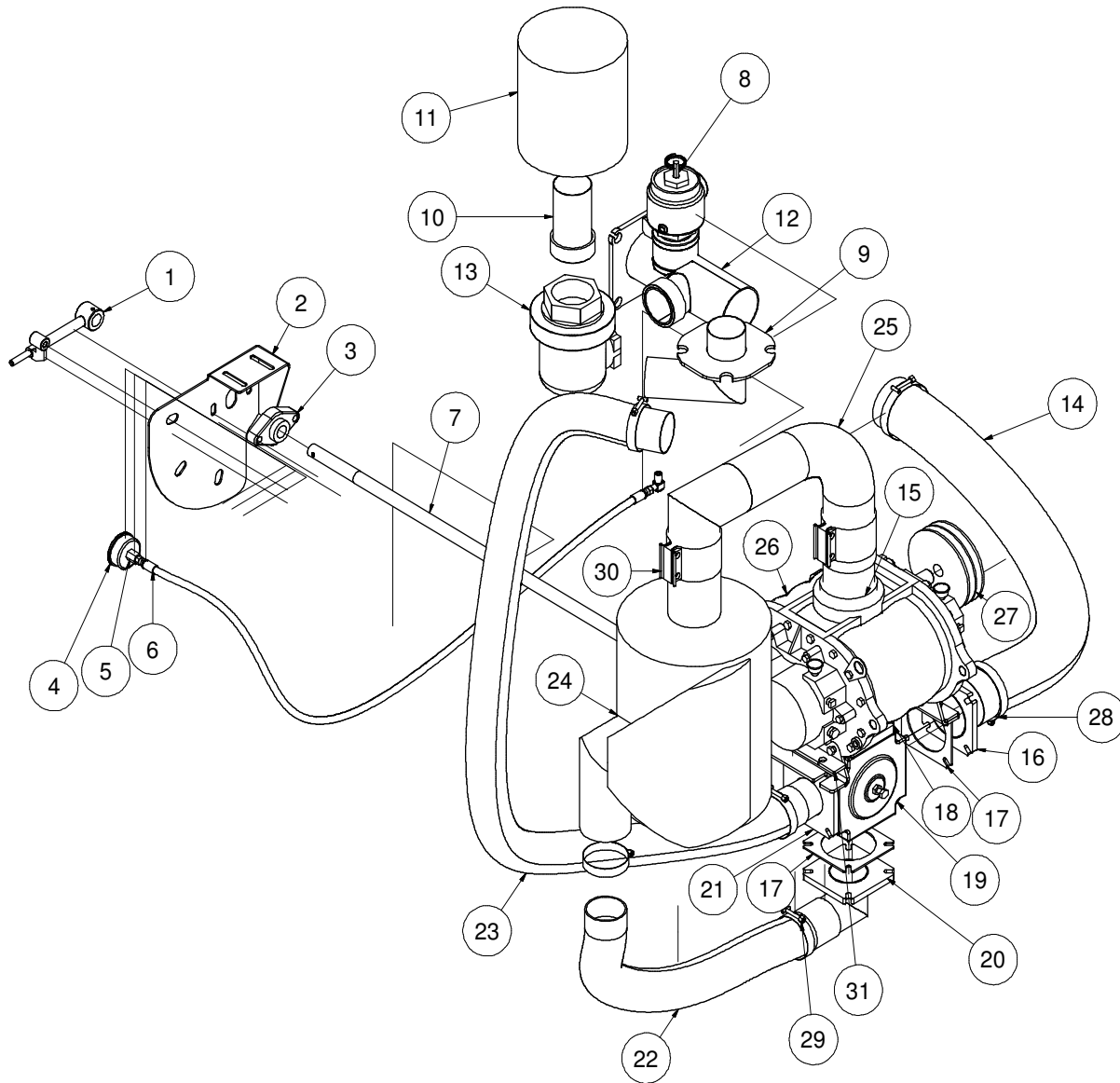

040813-E

VACASSY01203

Blower Assembly

67/99HP 1025CFM JETTER

| ITEM | QTY | NUMBER | DESCRIPTION |
|------|-----|------------|--|
| 1 | 1 | 8041617 | REVERSE FLOW HANDLE, TRAILER UNIT |
| | 1 | 8041177-10 | HANDLE GRIP |
| 2 | 1 | 8046202 | BRACKET REV FLOW CONTROL LE |
| | 3 | 8048585 | GROMMET, .884/.878 X .266 X .234 |
| 3 | 1 | W030080 | FLANGE BEARING - 2 BOLT (1" BORE) |
| 4 | 1 | 8041074 | GAUGE COMPOUND PRESSURE/VACUUM |
| 5 | 1 | T400110 | UNION 4FP-4MJ |
| 6 | 1 | 8045869 | HOSE ASSY VAC 4-34" ST-ST |
| 7 | 1 | 8048342 | REV FLOW UNIVERSAL JOINT RD SHAFT 49LE |
| 8 | 1 | 8041035 | PRESSURE RELIEF 1025 |
| 9 | 1 | 8046218 | EXHAUST REV FLOW PIPE WELDMENT |
| 10 | 1 | 8045238 | UNION EXHAUST 3" OD-MNPT |
| 11 | 1 | 8043553 | AIR FILTER 3" 245 CFM |
| 12 | 1 | 8048126 | 4" HEADER AIR FILTER HDRF |
| | 1 | 8048127 | HEADER, 4" AIR FILTER V2000/V2200 |
| | 1 | 8048128 | HEADER, 4" AIR FILTER V2600/V3000 |
| | 1 | 8046191 | GASKET, HEADER |
| 13 | 1 | 8030866 | BAYCO VALVE |
| 14 | 1 | 8046575 | HOSE VAC AG SUCTION 4 - 51" |
| 15 | 1 | 8030560 | 4" HOSE COUPLING WELDMENT |
| 16 | 1 | 8046484 | EXHAUST REV FLOW 4" X 4" FLANGE WELDMENT |
| 17 | 4 | 8043554 | ADAPTER VALVE FLANGE |
| 18 | 1 | 8044330 | REV FLOW 4" HEADER NIP ASSY |
| 19 | 1 | 8041177 | 4" 4-WAY VALVE |
| 20 | 1 | 8046201 | ELBOW EXHAUST 3" W/ 4" FLANGE |
| 21 | 1 | 8046222 | EXHAUST REV FLOW 3" X 4" FLANGE WELDMENT |
| 22 | 1 | 8046576 | HOSE VAC AG SUCTION 3 - 29" |
| 23 | 1 | 8046577 | HOSE VAC AG SUCTION 3 - 65" |
| 24 | 1 | 8030917 | SILENCER, 1025 CFM, COWL |
| 25 | 1 | 8046505 | EXHAUST 4" ID-OD W/COUPLING WELDMENT |
| 26 | 1 | 8040001 | BLOWER (MODEL 59) |
| 27 | 1 | 8040703 | SHEAVE 6.15" OD SDS 2-GROOVE |
| | 1 | 8040485 | BUSHING 1 1/8" SDS |
| | 2 | 8049160 | BELTS, BP52 |
| | 1 | 8041798 | RETAINER |
| 28 | 2 | 8042606 | CLAMP HOSE T-BOLT 450 |
| 29 | 4 | 8042605 | CLAMP HOSE T-BOLT 350 |
| 30 | 2 | 8030400 | 4" BAND CLAMP |

040813-E

VACASSY01203

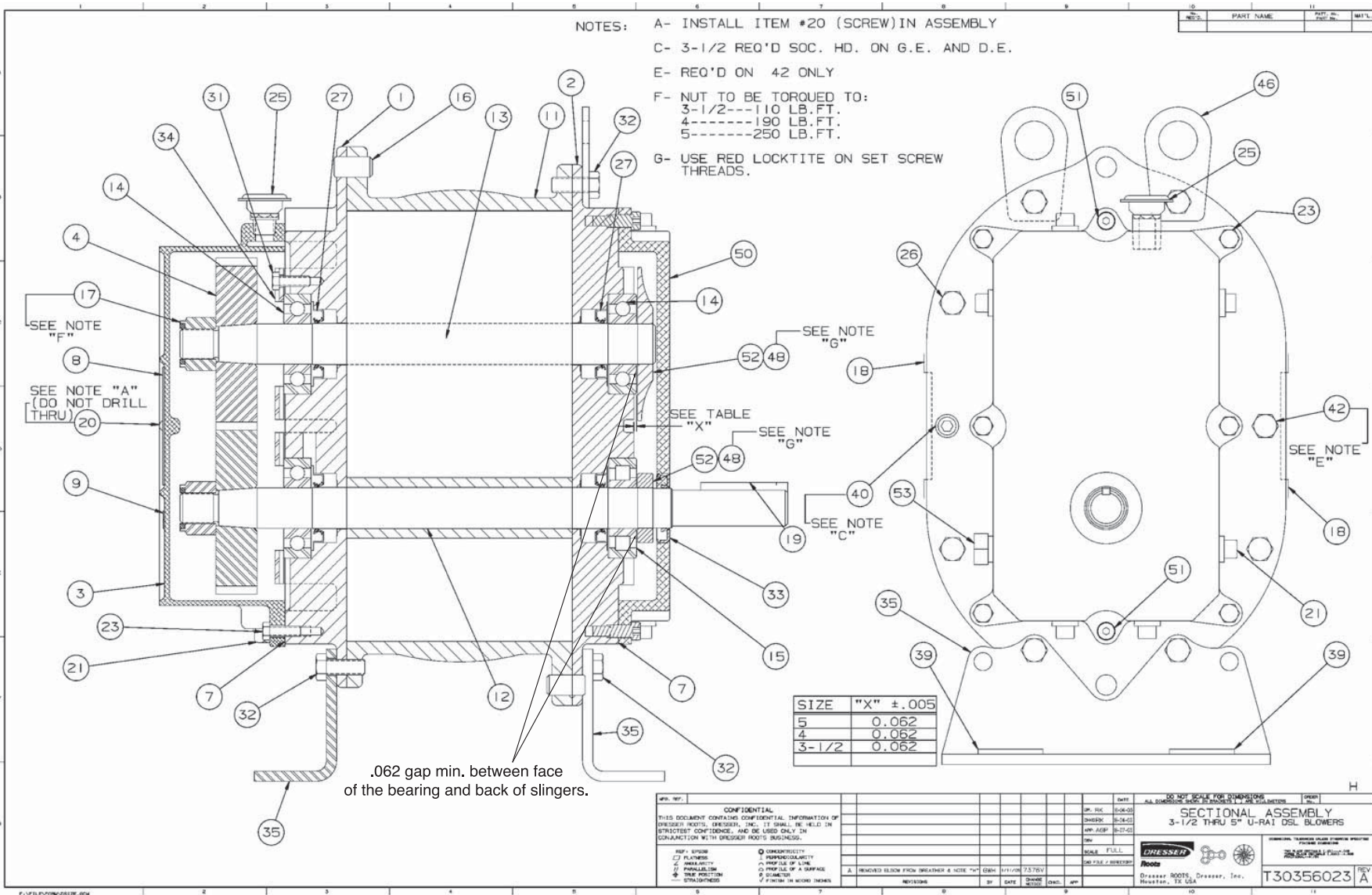

Assembly of URAI DSL Blowers with Splash Lubricated Drive End 3-5" Gear Diameter

**URAI-DSL Splash Lubricated Blowers
5" Gear Diameter**

| Item # | Qty | Part # | Description |
|--------|-----|------------|----------------------------|
| 1 | 1 | 8040001-1 | Headplate Gear End |
| 2 | 1 | 8040001-2 | Headplate Drive End |
| 3 | 1 | 8040001-3 | Gearbox |
| 4 | 2 | 8040001-4 | Timing Gears |
| 7 | 1 | 8040001-7 | Gasket, Gear Box, DE Cover |
| 11 | 1 | 8040001-11 | Cylinder |
| 12 | 1 | 8040001-12 | Impeller & Shaft Drive |
| 13 | 1 | 8040001-13 | Impeller & shaft Driven |
| 14 | 3 | 8040001-14 | Bearing, Ball |
| 15 | 1 | 8040001-15 | Bearing, Roller |
| 16 | 4 | 8040001-16 | Pin, Dowel |
| 17 | 2 | 8040001-17 | Gear Nut |
| 19 | 1 | 8040001-19 | Key |
| 21 | 3 | 8040001-21 | Plug, Pipe |
| 23 | 6 | 8040001-23 | Screw Hex |
| 25 | 1 | 8040001-25 | Breather (Plug Vent) |
| 26 | * | 8040001-26 | Screw, Hex |
| 27 | 4 | 8040001-27 | Seal, Lip Bearing |
| 31 | 4 | 8040001-31 | Screw, Hex, Nylock |
| 32 | 6 | 8040001-32 | Screw, Hex |
| 33 | 1 | 8040001-33 | Seal Lip-Drive |
| 34 | 2 | 8040001-34 | Clamp Plate |
| 35 | 2 | 8040001-35 | Foot |
| 39 | 4 | 8040001-39 | Washer Mounting |
| 40 | 2 | 8040001-40 | Screw Socket |
| 42 | 2 | 8040001-42 | Screw Hex |
| 48 | 4 | 8040001-48 | DE Oil Slinger Set Screw |
| 50 | 1 | 8040001-50 | Drive End Cover |
| 52 | 2 | 8040001-52 | Drive End Oil Slinger |
| 53 | 2 | 8040001-53 | Oil Sight Glass |

*Quantities vary by blower.

Blower Assembly

XT

| ITEM | QTY | NUMBER | DESCRIPTION |
|------|-----|---------|----------------------------------|
| 1 | 1 | 8030917 | SILENCER, 1025CFM, COWL |
| 2 | 1 | 8031193 | CLAMP, 4" U-BOLT EXHAUST |
| 3 | 1 | 8047063 | EXHAUST 1200CFM BLOWER TOP |
| 4 | 2 | 8046996 | GASKET, BLOWER FLANGE ROOTS 412 |
| 5 | 1 | 8045164 | 412 BLOWER |
| | 1 | 8045310 | SHEAVE, 6.35"OD SD 3-GROOVE |
| | 1 | 8045305 | BUSHING, 1 1/2" SD |
| | 2 | 8049066 | BELT, BP55 GP |
| | 2 | 8041507 | TENSION ROD |
| | 1 | 8047006 | TENSION BLOCK |
| 6 | 1 | 8047059 | BLOWER FLANGE / ELBOW WELDMENT |
| 7 | 1 | 8047065 | HOSE VAC AG SUCTION 4-10" |
| 8 | 1 | 8041814 | ELBOW, 90 4" (4" RAD, OD-OD) |
| 9 | 4 | 8042606 | CLAMP, T-BOLT 4" (350) |
| 10 | 1 | 8044511 | HOSE VAC AG SUCTION 4-36" |
| 11 | 1 | 8030866 | BAYCO VALVE |
| 12 | 1 | 8045238 | UNION EXHAUST 3" OD - MNPT |
| 13 | 1 | 8043553 | AIR FILTER, 3" 245CFM |
| 14 | 1 | 8046415 | HEADER AIR FILTER HDRF |
| | 1 | 8046191 | HEADER GASKET |
| 15 | 1 | 8045869 | HOSE ASSY VAC 4 - 34" ST-ST |
| 16 | 1 | T400110 | UNION, 4FP - 4MJ |
| 17 | 1 | 8041074 | GAUGE COMPOUND PRESSURE / VACUUM |

040513-E

VACASSY239

Blower Assembly

XTRF

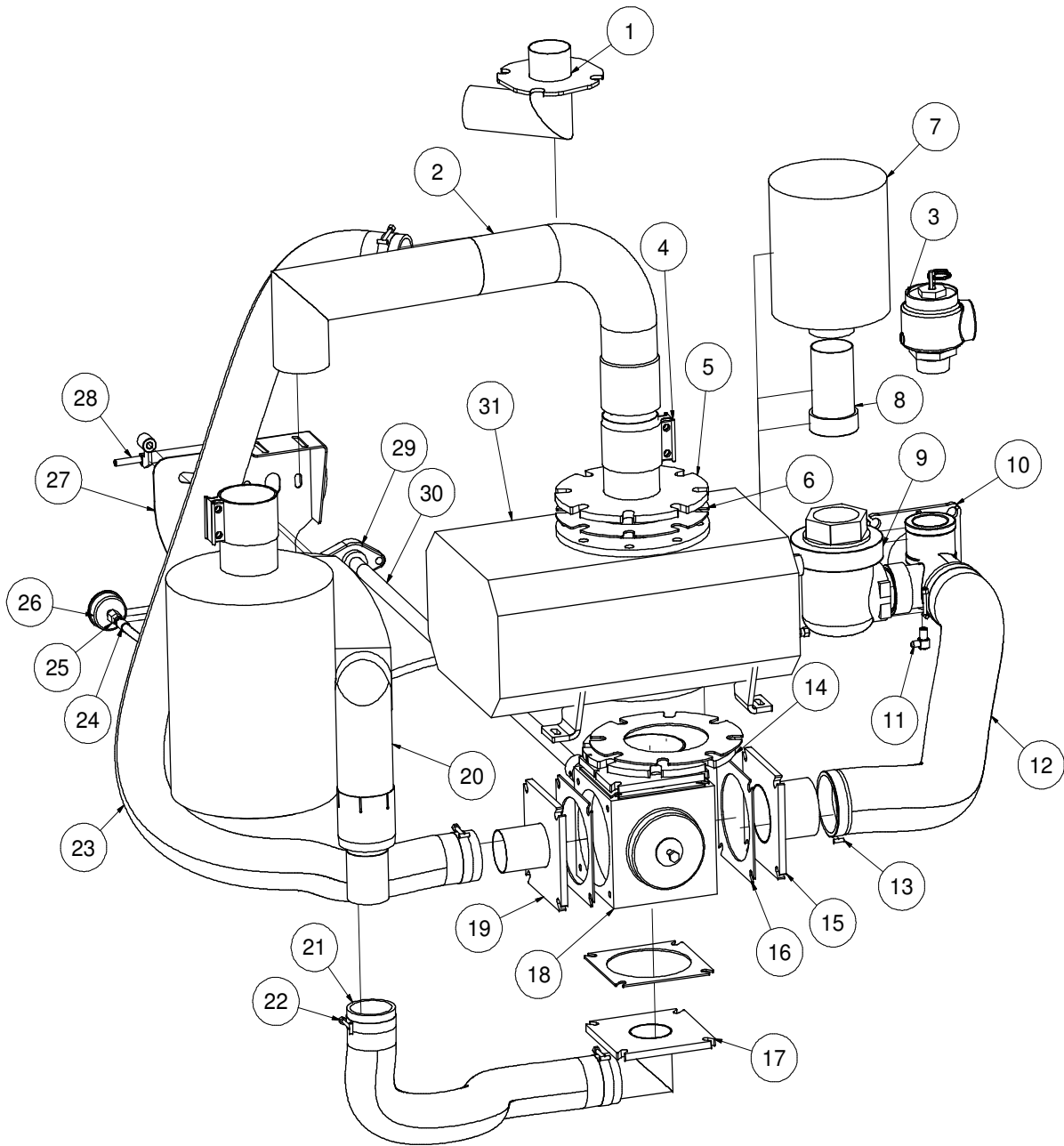

040513-E

VACASSY236

Blower Assembly

XTRF

| ITEM | QTY | NUMBER | DESCRIPTION |
|------|-----|---------|--|
| 1 | 1 | 8046218 | EXHAUST REV FLOW PIPE WELDMENT |
| 2 | 1 | 8046986 | EXHAUST 4" ID-OD W/ COUPLING WELDMENT |
| 3 | 1 | 8041305 | PRESSURE RELIEF 1025 |
| 4 | 2 | 8030400 | 4" BAND CLAMP |
| 5 | 1 | 8046988 | BLOWER OUTLET ROOTS 412 |
| 6 | 2 | 8046996 | GASKET, BLOWER FLANGE ROOTS 412 |
| 7 | 1 | 8043553 | AIR FILTER, 3" 245CFM |
| 8 | 1 | 8045238 | UNION EXHAUST 3" OD-MNPT |
| 9 | 1 | 8030866 | BAYCO VALVE |
| 10 | 1 | 8048126 | 4" HEADER AIR FILTER HDRF |
| | 1 | 8048127 | HEADER,4" AIR FILTER V2000/V2200 |
| | 1 | 8048128 | HEADER,4" AIR FILTER V2600/3000 |
| | 1 | 8046191 | GASKET, HEADER |
| 11 | 1 | T401100 | ELBOW, 4MP - 4MJ 90 |
| 12 | 1 | 8046575 | HOSE VAC AG SUCTION 4-51" |
| 13 | 2 | 8042606 | CLAMP, T-BOLT 4" (350) |
| 14 | 1 | 8048089 | BRACKET REV FLOW BLOWER TO 4-WAY VALVE |
| 15 | 1 | 8046984 | FLANGE EXHAUST 4-WAY 6" X 4" TUBE |
| 16 | 4 | 8046995 | GASKET, FLANGE 4-WAY VALVE 6" |
| 17 | 1 | 8046981 | ELBOW EXHAUST 90 3" W/ FLANGE |
| 18 | 1 | 8045829 | VALVE, 4-WAY 6" |
| 19 | 1 | 8046985 | FLANGE EXHAUST 4-WAY 6" X 3" TUBE |
| 20 | 1 | 8030917 | SILENCER, 1025CFM, COWL |
| 21 | 1 | 8046576 | HOSE VAC AG SUCTION 3-65" |
| 22 | 2 | 8042605 | CLAMP T-BOLT 3" (350) |
| 23 | 1 | 8046577 | HOSE VAC AG SUCTION 4-34" |
| 24 | 1 | 8045869 | HOSE ASSY VAC 4-34" ST-ST |
| 25 | 1 | 8030483 | UNION, 4FP - 4MJ |
| 26 | 1 | 8041074 | GAUGE, VACUUM COMPOUND PRESSURE |
| 27 | 1 | 8046202 | BRACKET, REV FLOW CONTROL LE |
| | 3 | 8048585 | GROMMET, .884/.878 X .266 X .234 |
| 28 | 1 | 8041617 | REV. FLOW HANDLE, TRAILER UNIT |
| 29 | 1 | W030080 | FLANGE BEARING - 2 BOLT (1" BORE) |
| 30 | 1 | 8048342 | REV FLOW UNIVERSAL JOINT RD SHAFT 49LE |
| 31 | 1 | 8045164 | 412 BLOWER ASSY |
| | 1 | 8045310 | SHEAVE, 6.35"OD SD 3-GROOVE |
| | 1 | 8045305 | BUSHING, 1 1/2" SD |
| | 2 | 8049066 | BELT, BP55 GP |
| * | 2 | 8041507 | TENSION ROD |
| * | 1 | 8047006 | TENSION BLOCK |

* NOT SHOWN

040513-E

VACASSY236

Blower Assembly

XT (JETTER)

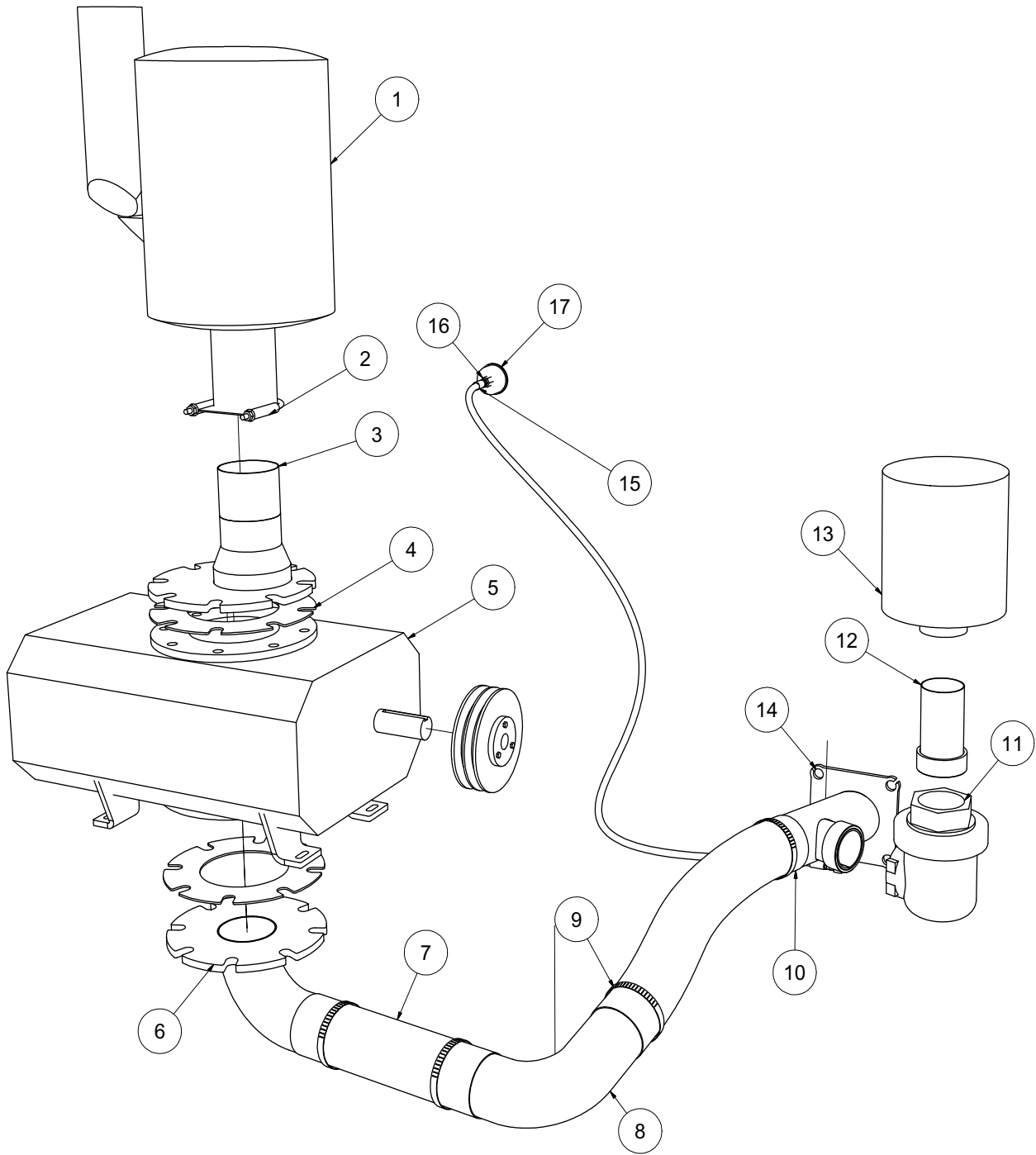

040513-E

VACASSY01201

Blower Assembly

**XT
(JETTER)**

| ITEM | QTY | NUMBER | DESCRIPTION |
|------|-----|---------|----------------------------------|
| 1 | 1 | 8030917 | SILENCER, 1025CFM, COWL |
| 2 | 1 | 8031193 | CLAMP, 4" U-BOLT EXHAUST |
| 3 | 1 | 8047063 | EXHAUST 1200CFM BLOWER TOP |
| 4 | 2 | 8046996 | GASKET, BLOWER FLANGE ROOTS 412 |
| 5 | 1 | 8045164 | 412 BLOWER |
| | 1 | 8045310 | SHEAVE, 6.35"OD SD 3-GROOVE |
| | 1 | 8045305 | BUSHING, 1 1/2" SD |
| | 2 | 8049070 | BELT, BP51 GP (JETTER UNIT ONLY) |
| | 2 | 8041507 | TENSION ROD |
| | 1 | 8047006 | TENSION BLOCK |
| 6 | 1 | 8047059 | BLOWER FLANGE / ELBOW WELDMENT |
| 7 | 1 | 8047065 | HOSE VAC AG SUCTION 4-10" |
| 8 | 1 | 8041814 | ELBOW, 90 4" (4" RAD, OD-OD) |
| 9 | 4 | 8042606 | CLAMP, T-BOLT 4" (350) |
| 10 | 1 | 8044511 | HOSE VAC AG SUCTION 4-36" |
| 11 | 1 | 8030866 | BAYCO VALVE |
| 12 | 1 | 8045238 | UNION EXHAUST 3" OD - MNPT |
| 13 | 1 | 8043553 | AIR FILTER, 3" 245CFM |
| 14 | 1 | 8046415 | HEADER AIR FILTER HDRF |
| | 1 | 8046191 | HEADER GASKET |
| 15 | 1 | 8045869 | HOSE ASSY VAC 4 - 34" ST-ST |
| 16 | 1 | T400110 | UNION, 4FP - 4MJ |
| 17 | 1 | 8041074 | GAUGE COMPOUND PRESSURE / VACUUM |

040513-E

VACASSY01201

Blower Assembly

XTRF JETTER

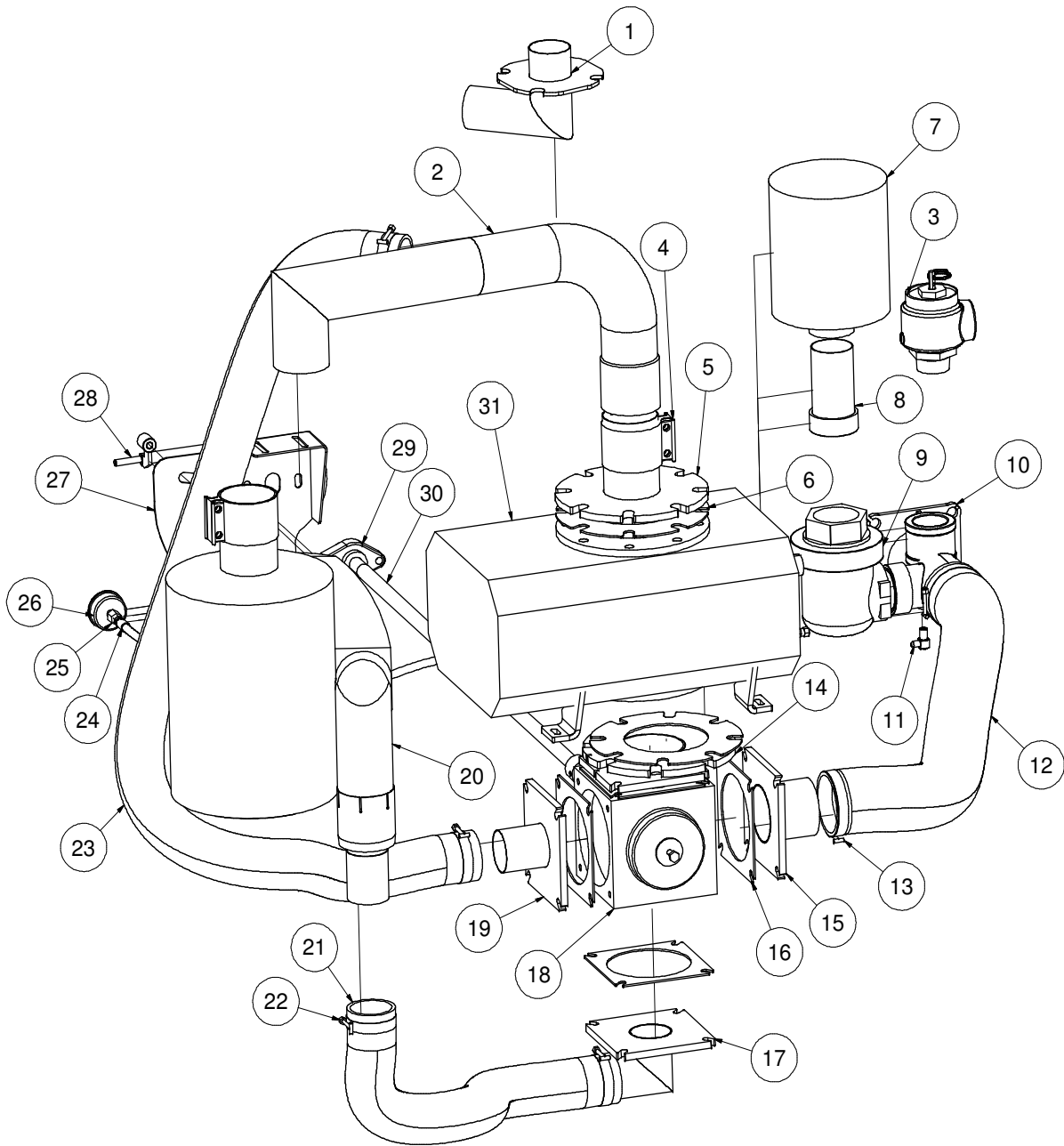

040513-E

VACASSY01202

Blower Assembly

XTRF JETTER

| ITEM | QTY | NUMBER | DESCRIPTION |
|------|-----|---------|--|
| 1 | 1 | 8046218 | EXHAUST REV FLOW PIPE WELDMENT |
| 2 | 1 | 8046986 | EXHAUST 4" ID-OD W/ COUPLING WELDMENT |
| 3 | 1 | 8041305 | PRESSURE RELIEF 1025 |
| 4 | 2 | 8030400 | 4" BAND CLAMP |
| 5 | 1 | 8046988 | BLOWER OUTLET ROOTS 412 |
| 6 | 2 | 8046996 | GASKET, BLOWER FLANGE ROOTS 412 |
| 7 | 1 | 8043553 | AIR FILTER, 3" 245CFM |
| 8 | 1 | 8045238 | UNION EXHAUST 3" OD-MNPT |
| 9 | 1 | 8030866 | BAYCO VALVE |
| 10 | 1 | 8048126 | 4" HEADER AIR FILTER HDRF |
| | 1 | 8048127 | HEADER,4" AIR FILTER V2000/V2200 |
| | 1 | 8048128 | HEADER,4" AIR FILTER V2600/3000 |
| | 1 | 8046191 | GASKET, HEADER |
| 11 | 1 | T401100 | ELBOW, 4MP - 4MJ 90 |
| 12 | 1 | 8046575 | HOSE VAC AG SUCTION 4-51" |
| 13 | 2 | 8042606 | CLAMP, T-BOLT 4" (350) |
| 14 | 1 | 8048089 | BRACKET REV FLOW BLOWER TO 4-WAY VALVE |
| 15 | 1 | 8046984 | FLANGE EXHAUST 4-WAY 6" X 4" TUBE |
| 16 | 4 | 8046995 | GASKET, FLANGE 4-WAY VALVE 6" |
| 17 | 1 | 8046981 | ELBOW EXHAUST 90 3" W/ FLANGE |
| 18 | 1 | 8045829 | VALVE, 4-WAY 6" |
| 19 | 1 | 8046985 | FLANGE EXHAUST 4-WAY 6" X 3" TUBE |
| 20 | 1 | 8030917 | SILENCER, 1025CFM, COWL |
| 21 | 1 | 8046576 | HOSE VAC AG SUCTION 3-65" |
| 22 | 2 | 8042605 | CLAMP T-BOLT 3" (350) |
| 23 | 1 | 8046577 | HOSE VAC AG SUCTION 4-34" |
| 24 | 1 | 8045869 | HOSE ASSY VAC 4-34" ST-ST |
| 25 | 1 | 8030483 | UNION, 4FP - 4MJ |
| 26 | 1 | 8041074 | GAUGE, VACUUM COMPOUND PRESSURE |
| 27 | 1 | 8046202 | BRACKET, REV FLOW CONTROL LE |
| | 3 | 8048585 | GROMMET, .884/.878 X .266 X .234 |
| 28 | 1 | 8041617 | REV. FLOW HANDLE, TRAILER UNIT |
| 29 | 1 | W030080 | FLANGE BEARING - 2 BOLT (1" BORE) |
| 30 | 1 | 8048342 | REV FLOW UNIVERSAL JOINT RD SHAFT 49LE |
| 31 | 1 | 8045164 | 412 BLOWER ASSY |
| | 1 | 8045310 | SHEAVE, 6.35"OD SD 3-GROOVE |
| | 1 | 8045305 | BUSHING, 1 1/2" SD |
| | 2 | 8049070 | BELT, BP51 GP (JETTER UNIT ONLY) |
| * | 2 | 8041507 | TENSION ROD |
| * | 1 | 8047006 | TENSION BLOCK |

* NOT SHOWN

040513-E

VACASSY01202

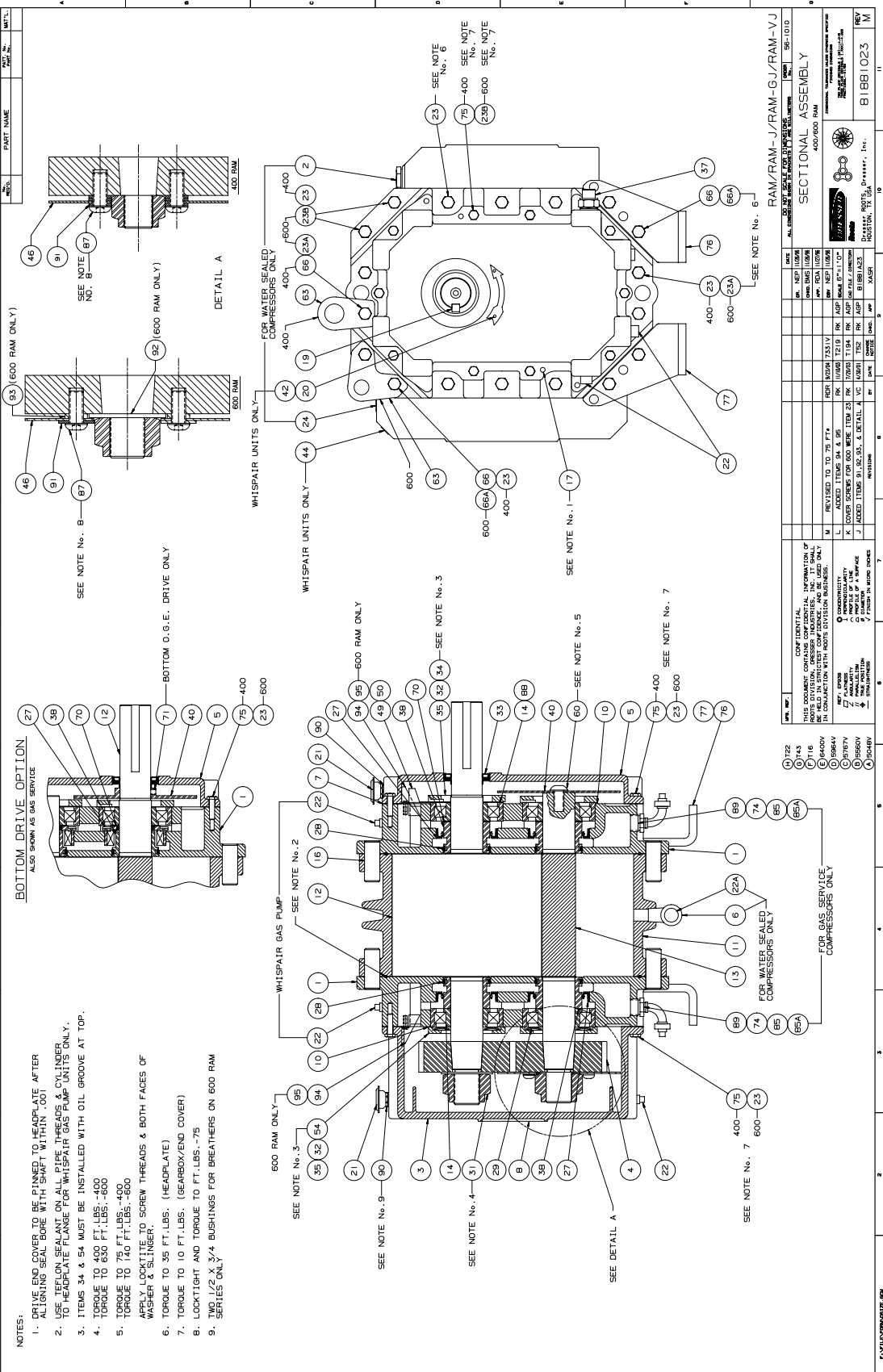

ASSEMBLY OF RAM SERIES -AIR & GAS BLOWERS

7-11-1986

RAM™ SERIES PARTS LIST 4" & 6" GEAR DIAMETER

(Refer to drawing #81881023)

| Item # | Part Name | Qty. |
|--------|----------------------------|------|
| 1 | Headplate | 2 |
| 3 | Gearbox | 1 |
| 4 | Timing Gears | 2 |
| 5 | End Cover | 1 |
| 7 | Gasket – Gearbox/Cover | 2 |
| 10 | Shims | Lot |
| 11 | Cylinder | 1 |
| 12 | Impeller & Shaft Drive | 1 |
| 13 | Impeller & Shaft Driven | 1 |
| 14 | Bearing Roller | 4 |
| 16 | Pin, Dowel (Pull Out) | 4 |
| 17 | Pin, Dowel | 2 |
| 19 | Key Square | 1 |
| 21 | Breather | 2 |
| 22 | Plug, Pipe | 12 |
| 23 | Screw, Cap Hex Hd. | * |
| 27 | Seal, Ben Binh. | 4 |
| 28 | Piston, Ring-Seal | 4 |
| 29 | Washer, Wavy Spring | 2 |
| 31 | Gear Nut | 2 |
| 32 | Scr, Cap Hex Hd. | 16 |
| 33 | Seal, Lip Drive | 1 |
| 34 | Brg. Clamp Plate - D. E. | 2 |
| 35 | Lock Washer - Spring | 16 |
| 37 | Sight Plug - Oil Level | 2 |
| 38 | Sleeve, Shaft | 4 |
| 40 | Slinger - D.E. (Top Drive) | 1 |
| 46 | Slinger - G.E. (Optional) | 1 |
| 49 | Oil Leader L/S | 1 |
| 50 | Oil, Leader-R/S | 1 |
| 54 | Brg Clamp Plate - G. E. | 2 |
| 60 | Screw, Cap Butt. HD. | 1 |
| 64 | Pin, Spring | 1 |
| 66 | Screw, Cap Hex HD. | * |
| 66.1 | Whispair, Spring Lock 3/8M | * |
| 70 | Shims D.E. Brg. | 1 |
| 75 | Screw, Cap - Hex HD. | * |
| 76 | Blower Foot - RH | 2 |
| 77 | Blower Foot - LH | 2 |
| 85 | Elb, Pipe-Black | 2 |
| 85.1 | Plug, Pipe | 2 |
| 87 | Scr, Cap BH | 2 |
| 88 | Anti Rotation Ball | 4 |
| 90 | BSHG-RDCG | 2 |
| 91 | Washer, Plain Flat | 2 |
| 92 | Washer, Plain Flat | 2 |
| 93 | Washer | 2 |

*Quantity varies by blower.

Water Pump Assembly

TS2021

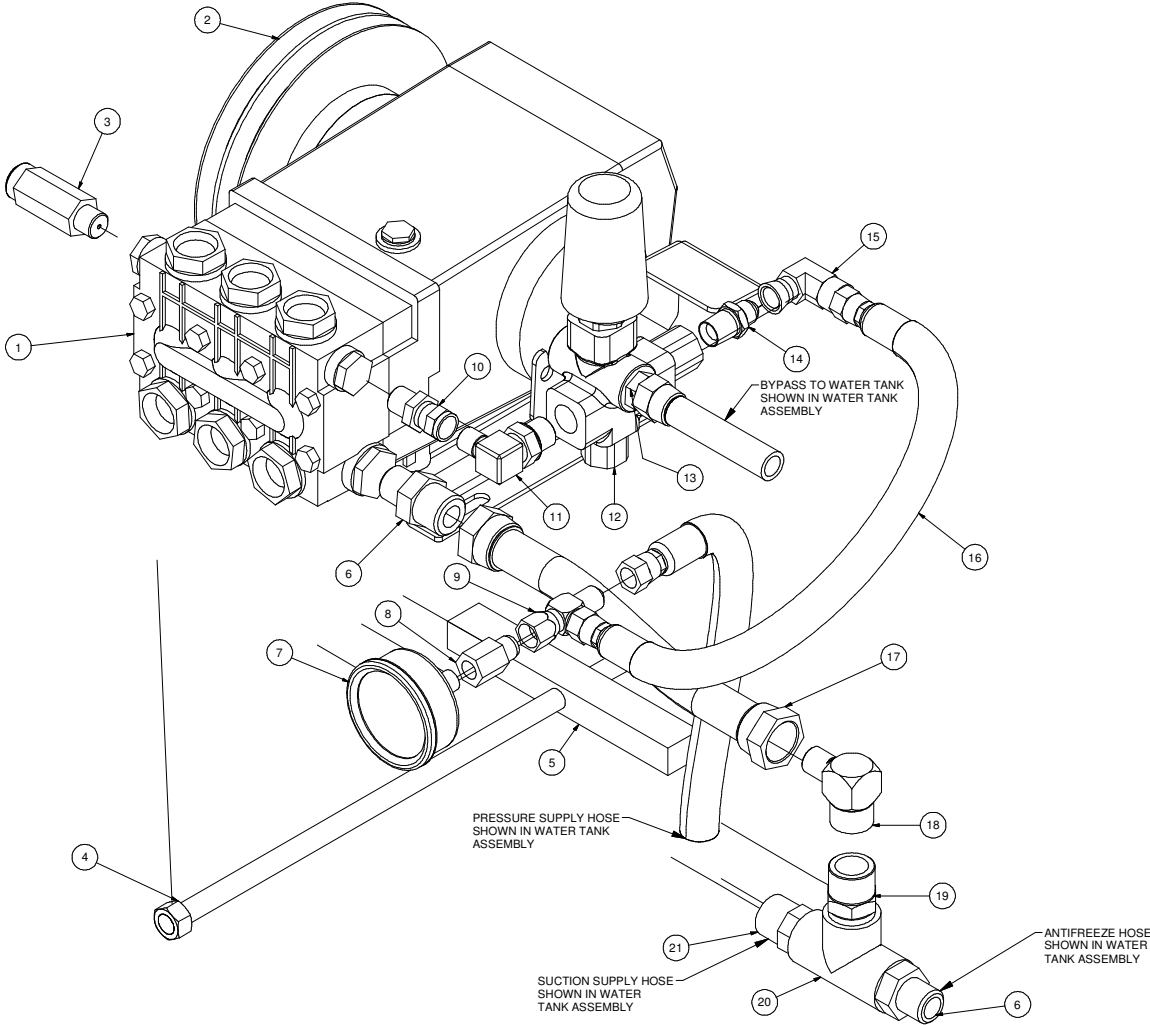

030713-E

VACASSY302

Water Pump Assembly

TS2021

| ITEM | QTY | PART NO. | DESCRIPTION |
|------|-----|----------|----------------------------------|
| 1 | 1 | 8031279 | WATER PUMP |
| | 4 | U000420 | SCREW, HC 3/8"-16 X 1" |
| | 4 | U210060 | WASHER, LOCK 3/8" |
| | 4 | U200600 | WASHER, FLAT 3/8" |
| 2 | 1 | 8030961 | WATER PUMP CLUTCH |
| | 1 | U410094 | KEY 5/16" X 5/16" X 1 3/8" |
| 3 | 1 | 8030340 | SAFETY RELIEF VALVE 6GPM |
| 4 | 1 | 8040751 | ROD TIGHTENER WELDT |
| 5 | 1 | 8040893 | TENSIONER BLOCK, ADJUSTING |
| 6 | 2 | T400080 | REDUCER, 12MP-8MJ |
| 7 | 1 | 8030372 | WATER PRESSURE GAUGE 1/4"NPT |
| 8 | 1 | 8031126 | REDUCER, 1/4"FP - 3/8"FJ |
| 9 | 1 | T402153 | TEE, 6MJ - 6MJ - 6FJ |
| 10 | 1 | T401125 | REDUCER, 3/8"MP - 1/2"FJ |
| 11 | 1 | T401120 | ELBOW, 90 3/8"MP - 1/2"MJ |
| 12 | 1 | 8040177 | VALVE, UNLOADER PULSAR 3 |
| 13 | 1 | T400030 | REDUCER, 6MP - 8MJ |
| 14 | 1 | T400028 | ADAPTER,STR 6MP - 6MJ, STEEL |
| 15 | 1 | T401228 | ELBOW, 90 3/8"FJ - 3/8"MJ |
| 16 | 1 | 8046817 | HOSE ASSY VAC 6-32" ST-ST |
| 17 | 1 | 8040972 | HOSE VAC PUSH 12 - 8 1/2"LG |
| | 2 | 8030525 | FITTING, HOSE #12FJ PUSHLOCK |
| 18 | 1 | T401160 | ELBOW,90 3/4"MJ - 1/2"MJ |
| 19 | 1 | T400080 | REDUCER, 12MP - 8MJ |
| 20 | 1 | T402160 | TEE, 3/4"FP - 3/4"FP - 3/4"FP |
| 21 | 1 | T400100 | UNION, 12MP - 12MJ |
| * | 2 | 8041803 | BELT, AX 47 (67/73HP) |
| | 2 | 8034157 | BELT, AX 39 (36HP) |
| | 2 | 8041082 | BELT, AX 48 (99HP COMP 1025 CFM) |
| | 2 | 8040878 | BELT, AX 45 (49HP) |

* NOT SHOWN

030713-E

VACASSY302

Water Pump TS2021

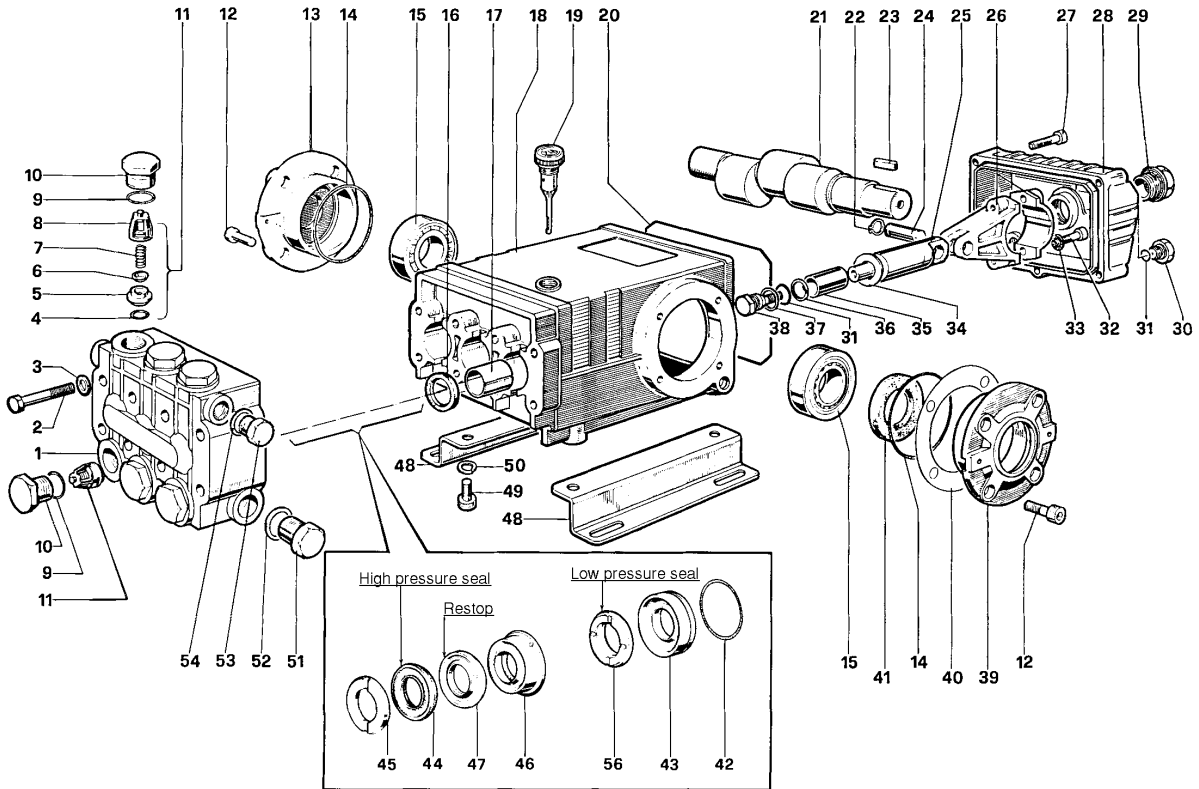

TORQUE SPECS*

*Decrease torque by 20%
if threads are lubricated

| Position | Ft. Lbs. | N-M |
|----------|----------|------|
| 2 | 22.1 | 29.9 |
| 10 | 73.7 | 99.9 |
| 12 | 14.7 | 19.2 |
| 27 | 7.3 | 9.9 |
| 29 | 13.2 | 17.9 |
| 30 | 14.7 | 19.2 |
| 32 | 14.7 | 19.2 |
| 38 | 14.7 | 19.2 |
| 49 | 29.4 | 39.8 |
| 51 | 29.4 | 39.8 |
| 53 | 29.4 | 39.8 |

Water Pump TS2021

| ITEM | QTY. | PART # | DESCRIPTION | KIT # | ITEM #'S | NO. OF ASSY | NO. OF CYL KIT |
|------|------|------------|----------------------|---------------|--------------------|-------------|----------------|
| | | | | | INCL'D IN KIT | IN KIT | WILL SERVICE |
| 1 | 1 | 8031280-1 | Manifold | | | | |
| 2 | 8 | 8031280-2 | Screw, M8 x 70 | | | | |
| 3 | 8 | 8031280-3 | Washer, M8 x 4 | | | | |
| 4 | 8 | 8031280-4 | O-ring, .674 x .103 | 8031280-KIT1 | 4, 5, 6, 7, 8 (11) | 6 | 3 |
| 5 | 6 | 8031280-5 | Seat, Valve | 8031280-KIT2 | 16 | 3 | 3 |
| 6 | 6 | 8031280-6 | Plate, Valve | | | | |
| 7 | 6 | 8031280-7 | Spring | 8031280-KIT3 | 41 | 2 | 0 |
| 8 | 6 | 8031280-8 | Guide, Valve | | | | |
| 9 | 6 | 8031280-9 | O-ring,.797x.103 | 8031280-KIT4 | 9, 10 | 6 | 3 |
| 10 | 6 | 8031280-10 | Cap | | | | |
| 11 | 6 | 8031280-11 | Valve Assembly | 8031280-KIT5 | 9, 10 | 6 | 3 |
| 12 | 8 | 8031280-12 | Screw, M8 x 16 | | | | |
| 13 | 1 | 8031280-13 | Cover, Crankcase | 8031280-KIT6 | 31, 34 | 3 | 3 |
| 14 | 2 | 8031280-14 | O-ring, 2.675 x .103 | | | | |
| 15 | 2 | 8031280-15 | Bearing, Roller | | | | |
| 16 | 3 | 8031280-16 | Seal, Oil | | 36, 37, 38 | | |
| 17 | 3 | 8031280-17 | Bushing | 8031280-KIT7 | 45 | 6 | 3 |
| 18 | 1 | 8031280-18 | Crankcase | | | | |
| 19 | 1 | 8031280-19 | Oil Dip Stick | 8031280-KIT10 | 42, 43 | 3 | 3 |
| 20 | 1 | 8031280-20 | O-ring, Cover | | | | |
| 21 | 1 | 8031280-21 | Crankshaft | 8031280-KIT28 | 42, 43, 44, | 1 | 1 |
| 22 | 6 | 8031280-22 | Ring, Snap | | | | |
| 23 | 1 | 8031280-23 | Key | | 45, 45, 47, 56 | | |
| 24 | 3 | 8031280-24 | Pin, Wrist | | | | |
| 25 | 3 | 8031280-25 | Guide, Plunger | 8031280-KIT69 | 44, 47, 56 | 3 | 3 |
| 26 | 3 | 8031280-26 | Rod, Connecting | | | | |
| 27 | 5 | 8031280-27 | Screw, M6 x 30 | 8031280-KIT71 | 46, 47 | 3 | 3 |
| 28 | 1 | 8031280-28 | Cover, Crankcase | | | | |
| 29 | 6 | 8031280-29 | Oil Indicator | | | | |
| 30 | 1 | 8031280-30 | Cap | | | | |
| 31 | 4 | 8031280-31 | O-ring,.426x.070 | | | | |
| 32 | 6 | 8031280-32 | Screw, M8 x 35 | | | | |
| 33 | 6 | 8031280-33 | Washer, M8.4 | | | | |
| 34 | 3 | 8031280-34 | Washer, M14 | | | | |
| 35 | 3 | 8031280-35 | Plunger (20 mm) | | | | |
| 37 | 3 | 8031280-37 | Washer | | | | |
| 38 | 3 | 8031280-38 | Screw, Plunger | | | | |
| 39 | 1 | 8031280-39 | Cover, Crankcase | | | | |
| 40 | 2 | 8031280-40 | Shim | | | | |
| 41 | 1 | 8031280-41 | Seal, Oil | | | | |
| 42 | 3 | 8031280-42 | O-ring, 1.364x.070 | | | | |
| 43 | 3 | 8031280-43 | Retainer, Packing | | | | |
| 44 | 3 | 8031280-44 | Packing | | | | |
| 45 | 3 | 8031280-45 | Ring, Head, M20 | | | | |
| 46 | 3 | 8031280-46 | Intermed. Ring | | | | |
| 47 | 3 | 8031280-47 | Testop Ring | | | | |
| 48 | 2 | 8031280-48 | Pump Feet | | | | |
| 49 | 4 | 8031280-49 | Screw, M10 x 18 | | | | |
| 50 | 4 | 8031280-50 | Washer, M10.2 | | | | |
| 51 | 1 | 8031280-51 | Cap | | | | |
| 52 | 1 | 8031280-52 | Washer, M21.5 | | | | |
| 53 | 1 | 8031280-53 | Cap | | | | |
| 54 | 1 | 8031280-54 | Washer, M17.5 | | | | |
| 56 | 3 | 8031280-56 | Seal,Low Press,20mm | | | | |

VACASSY325

Water Pump Assembly KE24

67HP

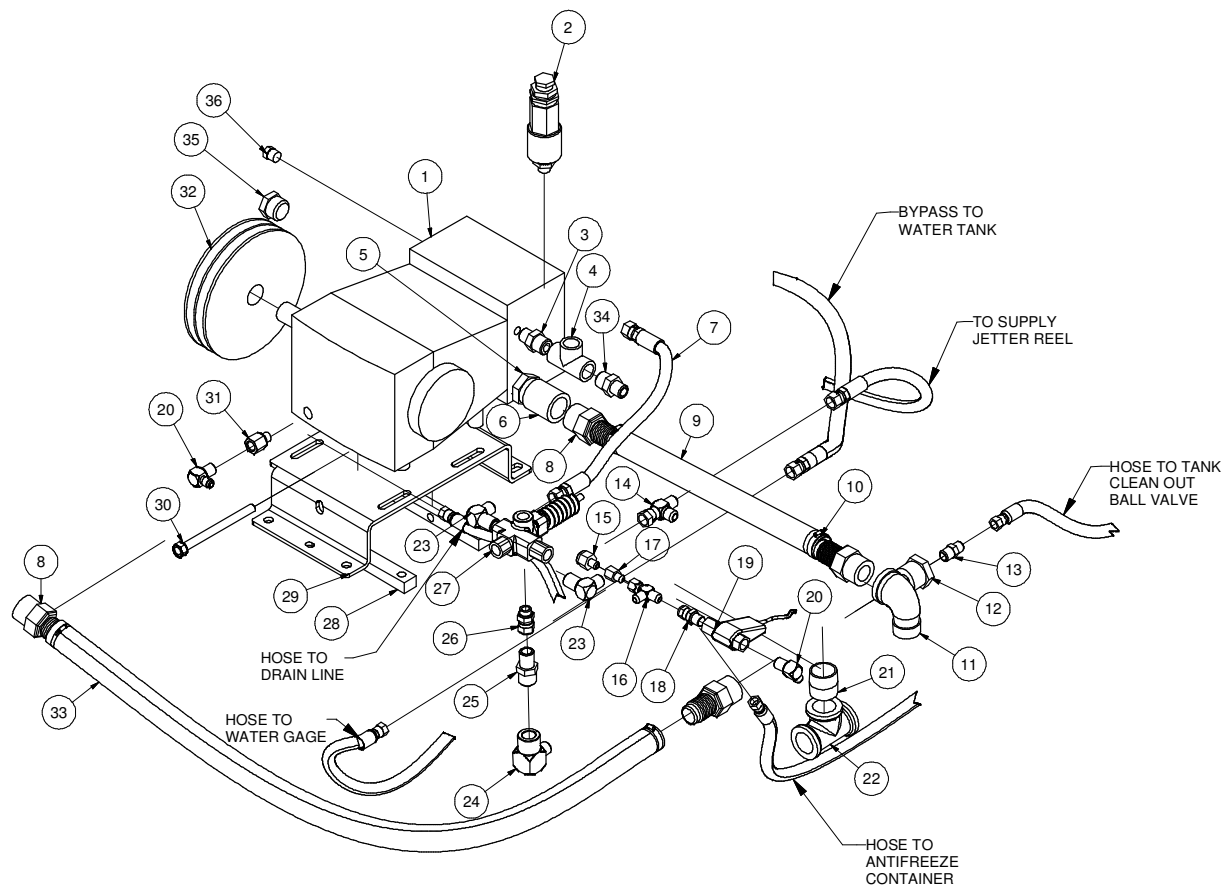

040813-E

VACASSY305

Water Pump Assembly KE24

67HP

| ITEM | QTY | PART NO. | DESCRIPTION |
|------|-----|----------|--------------------------------|
| 1 | 1 | 8042352 | WATER PUMP KE24 |
| 2 | 1 | 8040556 | SV2-300 SAFETY RELIEF VALVE |
| * | 1 | T400139 | UNION, 1/2 MP-1/2 FBSPP |
| * | 1 | T403085 | REDUCER, 3/4MP-1/2FP |
| 3 | 1 | T404030 | REDUCER, 1/2MP-3/4MP |
| 4 | 1 | T402160 | TEE, 3/4FP-3/4FP-3/4FP |
| 5 | 1 | T400618 | REDUCER, 1"MP X 1 1/4"MP |
| 6 | 1 | T422080 | COUPLING, 1 1/4" |
| 7 | 1 | 8044647 | HOSE ASSY VAC 8-14 ST-ST |
| 8 | 4 | 8041312 | FITTING, HOSE BARB 20HB-20MP |
| 9 | 1 | 8042940 | HOSE VAC CLEAR VINYL 1 1/4-18" |
| 10 | 4 | 8040677 | CLAMP, HOSE 1 1/2 |
| 11 | 1 | T420120 | STREET ELBOW 90 - 1 1/4" |
| 12 | 1 | T403110 | REDUCER, 1 1/4"MP-1/2"FP GALV |
| 13 | 1 | 8031291 | UNION, 1/2MP-3/8MJ |
| 14 | 1 | T402155 | TEE, 1/2"FJ-1/2"MJ-1/2"MJ |
| 15 | 1 | T403130 | UNION, 8FJ-6MJ |
| 16 | 1 | T402153 | TEE, 6MJ-6MJ-6FJ |
| 17 | 1 | 8042267 | ORIFICE 6MJ-6FJ .094" |
| 18 | 1 | T400813 | UNION, 6FJ-6MP |
| 19 | 1 | 8031267 | FLOW SWITCH |
| 20 | 2 | T401102 | ELBOW, 6MJ-6MP |
| 21 | 1 | T421040 | NIPPLE, PIPE 1 1/4"MNPT |
| 22 | 1 | 8041049 | TEE, 1 1/4" PIPE |
| 23 | 2 | T401140 | ELBOW, 8MP-8MJ |
| 24 | 1 | T401160 | ELBOW, 12MP-12MJ |
| 25 | 1 | T400070 | UNION, 1/2MP-3/4MJIC |
| 26 | 1 | T400814 | UNION, 8MP-8FJ |
| 27 | 1 | 8030341 | VALVE, UNLOADER, GREENSPRING |
| 28 | 2 | 8043317 | TENSIONER BLOCK, ADJUSTING |
| 29 | 1 | 8044167 | PUMP BRACKET KE24A |
| 30 | 1 | 8030020 | ROD, TENSIONER |
| 31 | 1 | T400119 | UNION, 3/8MBSPP X 3/8FP |
| 32 | 1 | 8043248 | SHEAVE, 9.75" OD SK 2-GROOVE |
| * | 1 | 8040644 | BUSHING, SK |
| * | 2 | 8049164 | BELT, BP61 |
| 33 | 1 | 8043076 | HOSE VAC CLEAR VINYL 1 1/4-37" |
| 34 | 1 | T400080 | REDUCER, 3/4"MP X 1/2"MJ |
| 35 | 1 | T405120 | PLUG, 1" MB |
| 36 | 1 | T405062 | PLUG, 1/2"NPT |

Water Pump Assembly KE24

99HP

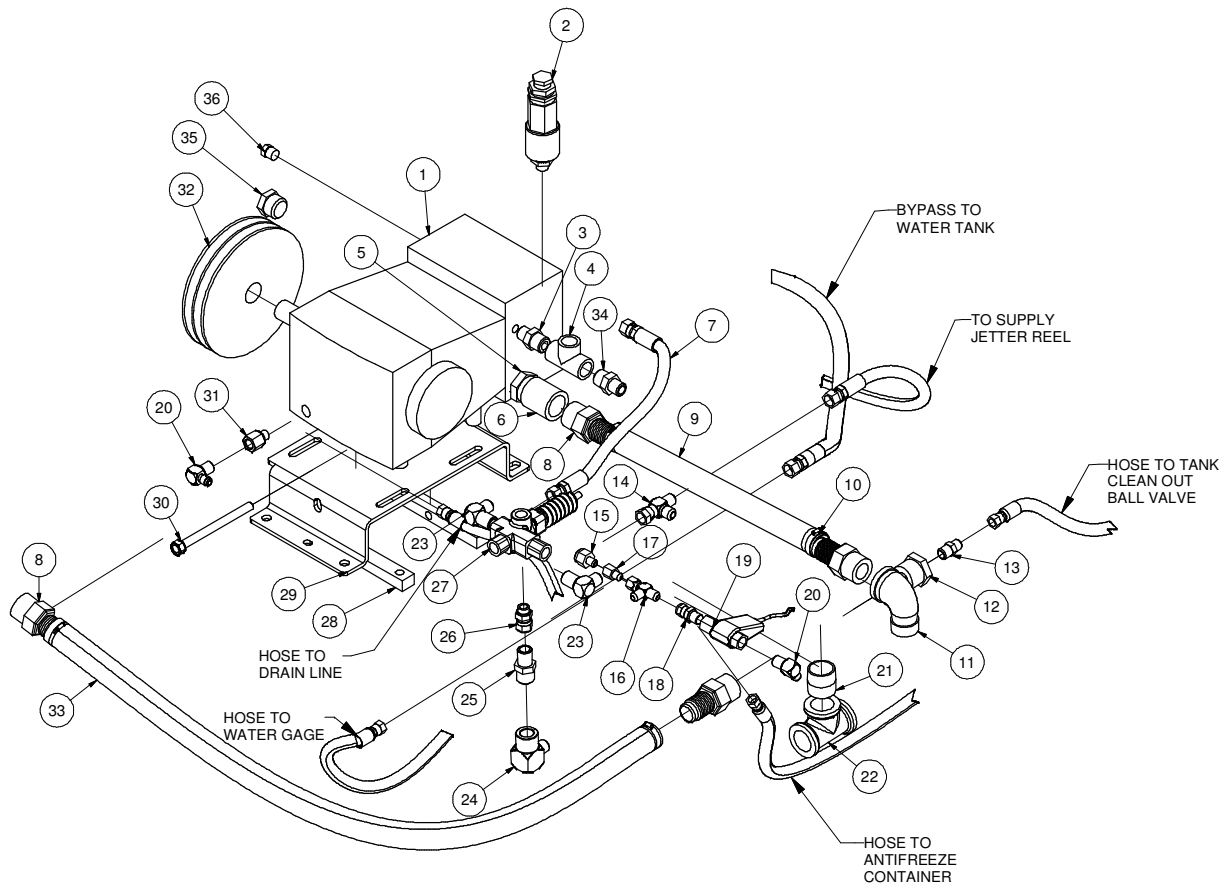

040813-E

VACASSY01302

Water Pump Assembly KE24

99HP

| ITEM | QTY | PART NO. | DESCRIPTION |
|------|-----|----------|--------------------------------|
| 1 | 1 | 8042352 | WATER PUMP KE24 |
| 2 | 1 | 8040556 | SV2-300 SAFETY RELIEF VALVE |
| * | 1 | T400139 | UNION, 1/2 MP-1/2 FBSPP |
| * | 1 | T403085 | REDUCER, 3/4MP-1/2FP |
| 3 | 1 | T404030 | REDUCER, 1/2MP-3/4MP |
| 4 | 1 | T402160 | TEE, 3/4FP-3/4FP-3/4FP |
| 5 | 1 | T400618 | REDUCER, 1"MP X 1 1/4"MP |
| 6 | 1 | T422080 | COUPLING, 1 1/4" |
| 7 | 1 | 8044647 | HOSE ASSY VAC 8-14 ST-ST |
| 8 | 4 | 8041312 | FITTING, HOSE BARB 20HB-20MP |
| 9 | 1 | 8042940 | HOSE VAC CLEAR VINYL 1 1/4-18" |
| 10 | 4 | 8040677 | CLAMP, HOSE 1 1/2 |
| 11 | 1 | T420120 | STREET ELBOW 90 - 1 1/4" |
| 12 | 1 | T403110 | REDUCER, 1 1/4"MP-1/2"FP GALV |
| 13 | 1 | 8031291 | UNION, 1/2MP-3/8MJ |
| 14 | 1 | T402155 | TEE, 1/2"FJ-1/2"MJ-1/2"MJ |
| 15 | 1 | T403130 | UNION, 8FJ-6MJ |
| 16 | 1 | T402153 | TEE, 6MJ-6MJ-6FJ |
| 17 | 1 | 8042267 | ORIFICE 6MJ-6FJ .094" |
| 18 | 1 | T400813 | UNION, 6FJ-6MP |
| 19 | 1 | 8031267 | FLOW SWITCH |
| 20 | 2 | T401102 | ELBOW, 6MJ-6MP |
| 21 | 1 | T421040 | NIPPLE, PIPE 1 1/4"MNPT |
| 22 | 1 | 8041049 | TEE, 1 1/4" PIPE |
| 23 | 2 | T401140 | ELBOW, 8MP-8MJ |
| 24 | 1 | T401160 | ELBOW, 12MP-12MJ |
| 25 | 1 | T400070 | UNION, 1/2MP-3/4MJIC |
| 26 | 1 | T400814 | UNION, 8MP-8FJ |
| 27 | 1 | 8030341 | VALVE, UNLOADER, GREENSPRING |
| 28 | 2 | 8043317 | TENSIONER BLOCK, ADJUSTING |
| 29 | 1 | 8044167 | PUMP BRACKET KE24A |
| 30 | 1 | 8030020 | ROD, TENSIONER |
| 31 | 1 | T400119 | UNION, 3/8MBSPP X 3/8FP |
| 32 | 1 | 8043248 | SHEAVE, 9.75" OD SK 2-GROOVE |
| * | 1 | 8040644 | BUSHING, SK |
| * | 2 | 8049165 | BELT, BP62 |
| 33 | 1 | 8043076 | HOSE VAC CLEAR VINYL 1 1/4-37" |
| 34 | 1 | T400080 | REDUCER, 3/4"MP X 1/2"MJ |
| 35 | 1 | T405120 | PLUG, 1" MB |
| 36 | 1 | T405062 | PLUG, 1/2"NPT |

OPTION FOR COMPRESSOR SET UP

| | | | |
|---|---|---------|---------------|
| * | 1 | 8046682 | PUMP, MOUNT |
| * | 2 | 8046731 | TENSION BLOCK |

Water Pump Assembly KE24

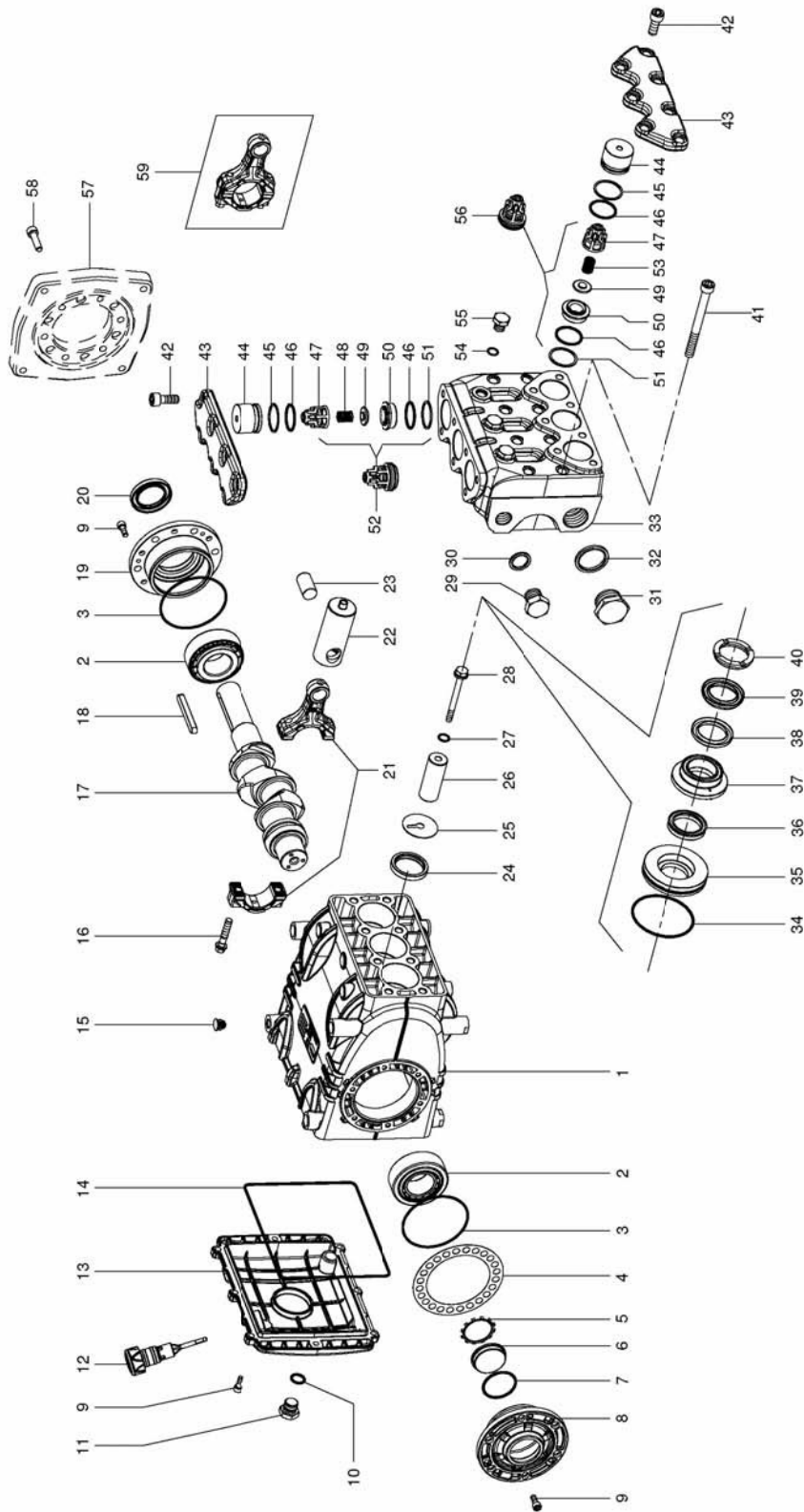

071509-E

VACASSY329

Water Pump Assembly KE24

| ITEM | QTY | PART NO. | DESCRIPTION |
|------|-----|------------|--|
| 1 | 1 | 8042352-1 | PUMP CRANKCASE |
| 2 | 2 | 8042352-2 | ROLLER BEARING 33207/Q |
| 3 | 2 | 8042352-3 | O-RING D. 80,6X2,62 |
| 4 | | 8042352-4 | SHIM 0,1 |
| | | * | SHIM, 25 |
| | | * | SHIM, 0,35 |
| 5 | 1 | 8042352-5 | RING ZJ45 |
| 6 | 1 | 8042352-6 | OIL LEVEL INDICATOR |
| 7 | 1 | 8042352-7 | O-RING D. 39,34X2,62 |
| 8 | 1 | 8042352-8 | OIL LEVEL INDICATOR SIDE BEARING COVER |
| 9 | 20 | 8042352-9 | SCREW TCEI M6X16 UNI 5931 |
| 10 | 1 | 8042352-10 | O-RING D. 13,95X2,62 |
| 11 | 1 | 8042352-11 | PLUG G3/8" |
| 12 | 1 | 8042352-12 | DIPSTICK |
| 13 | 1 | 8042352-13 | CRANKCASE COVER |
| 14 | 1 | 8042352-14 | O-RING D. 196,52X2,62 |
| 15 | 7 | 8042352-15 | PLUG FOR D. 15 PORT |
| 16 | 6 | 8042352-16 | CONNECTING ROD SCREW |
| 17 | 1 | 8042352-17 | CRANKSHAFT |
| 18 | 1 | 8042352-18 | CRANKSHAFT KEY |
| 19 | 1 | 8042352-19 | MOTOR SIDE BEARING COVER |
| 20 | 1 | 8042352-20 | OIL SEAL 35X52X7 SPEC |
| 21 | 3 | 8042352-21 | CONNECTING ROD |
| 22 | 3 | 8042352-22 | PISTON |
| 23 | 3 | 8042352-23 | PIN D. 18X36 |
| 24 | 3 | 8042352-24 | SEAL 36X47X7 |
| 25 | 3 | 8042352-25 | WIPER |
| 26 | 3 | 8042352-26 | PLUNGER KE24 |
| 27 | 3 | 8042352-27 | O-RING D. 11X2 SPEC |
| 28 | 3 | 8042352-28 | PLUNGER BOLT |
| 29 | 1 | 8042352-29 | PLUG G1/2"X18 |
| 30 | 1 | 8042352-30 | WASHER D.1/2" |
| 31 | 1 | 8042352-31 | PLUG G1"X17 |
| 32 | 1 | 8042352-32 | WASHER D.1" |
| 33 | 1 | 8042352-33 | MANIFOLD D22-24 |
| 34 | 3 | 8042352-34 | OR D.50C52X1.78 KIT 2002-3-4-5-6-7-8-9-10-11 |
| 35 | 3 | 8042352-35 | PACKING RETAINER D.24 |
| 36 | 3 | 8042352-36 | PACKING D.24 L.P. KIT 2006-2007 |
| 37 | 3 | 8042352-37 | MIDDLE RING D.24 KIT 2007 |
| 38 | 3 | 8042352-38 | RESTOP RING D.24 KIT 2006-2007 |
| 39 | 3 | 8042352-39 | PACKING D.24 H.P. KIT 2006-2007 |
| 40 | 3 | 8042352-40 | FRONT RING D.24 KIT 2007 |
| 41 | 8 | 8042352-41 | SCREW TCEI M10X110 UNI 5931 |
| 42 | 14 | 8042352-42 | SCREW TCEI M10X25 UNI 5931 SPEC. |
| 43 | 2 | 8042352-43 | VALVE COVER |
| 44 | 6 | 8042352-44 | VALVE PLUG |
| 45 | 6 | 8042352-45 | BACK UP RING D.32,4X36,5X1,5 |
| 46 | 12 | 8042352-46 | O-RING D.29.82X2,62 KIT 2000-2001 |
| 47 | 6 | 8042352-47 | SUCTION/DELIVERY VALVE GUIDE PLATE KIT 2000-2001 |
| 48 | 3 | 8042352-48 | DELIVERY VALVE SPRING KIT 2001 |
| 49 | 6 | 8042352-49 | SUCTION/DELIVERY VALVE PLATE KIT 2000-2001 |
| 50 | 6 | 8042352-50 | SUCTION/DELIVERY VALVE SEAT KIT 2000-2001 |
| 51 | 6 | 8042352-51 | BACK UP RING D.31X35,5X1,5 |
| 52 | 3 | 8042352-52 | DELIVERY VALVE ASSEMBLY KIT 2001 |
| 53 | 3 | 8042352-53 | SUCTION VALVE SPRING KIT 2000 |
| 54 | 3 | 8042352-54 | O-RING D.10,82X1,78 |
| 55 | 3 | 8042352-55 | PLUG G1/4"X13 |
| 56 | 3 | 8042352-56 | SUCTION VALVE ASSEMBLY KIT 2000 |
| 57 | 1 | 8042352-57 | HYDRAULIC MOTOR FLANGE |
| 58 | 6 | 8042352-58 | SCREW TCEI M8X30 UNI 5931 |
| 59 | 3 | 8042352-59 | CONNECTING ROD (COMPLETE) |

Water Pump Assembly

**TSP1821
5.5GPM
5000PSI**

| ITEM | QTY | PART NO. | DESCRIPTION |
|------|-----|----------|------------------------------------|
| 1 | 1 | 8048161 | WATER PUMP TSP1821 5.5GPM W/CLUTCH |
| | 1 | 8047240 | PUMP, WATER TSP1821 |
| | 1 | 8047241 | CLUTCH, ELECTRIC |
| | 2 | 8049163 | BELT, BP59 |
| | 1 | 8047256 | SHEAVE, 6.75"OD SDS 2GROOVE |
| 2 | 1 | 8048391 | VALVE, RELIEF 5500PSI |
| 3 | 1 | T405065 | PLUG, #12MP |
| 4 | 1 | 8047243 | BRACKET, WATER PUMP TSP1821 |
| 5 | 2 | T401125 | REDUCER, 3/8"MP - 1/2"FJ |
| 6 | 1 | T400613 | REDUCER, 1/2"MJ - 3/8"FP |
| 7 | 1 | T401561 | ELBOW, 45 1/2"MP - 3/4"MJ |
| 8 | 1 | T405030 | PLUG, 1/4"MP, HEX HEAD |
| 9 | 1 | T401140 | ELBOW, 8MP - 8MJ |
| 10 | 1 | T401102 | ELBOW, 3/8"MP - 3/8"MJ 90 |
| 11 | 1 | 8047242 | VALVE, UNLOADER |
| 12 | 1 | T400022 | REDUCER, 6FJ - 4MJ |
| 13 | 1 | T402153 | TEE, 6MJ - 6MJ - 6FJ |
| 14 | 1 | 8047724 | FLOW SWITCH |
| 15 | 1 | T400028 | UNION, 3/8"MP - 3/8"MJ |

Water Pump TSP1821

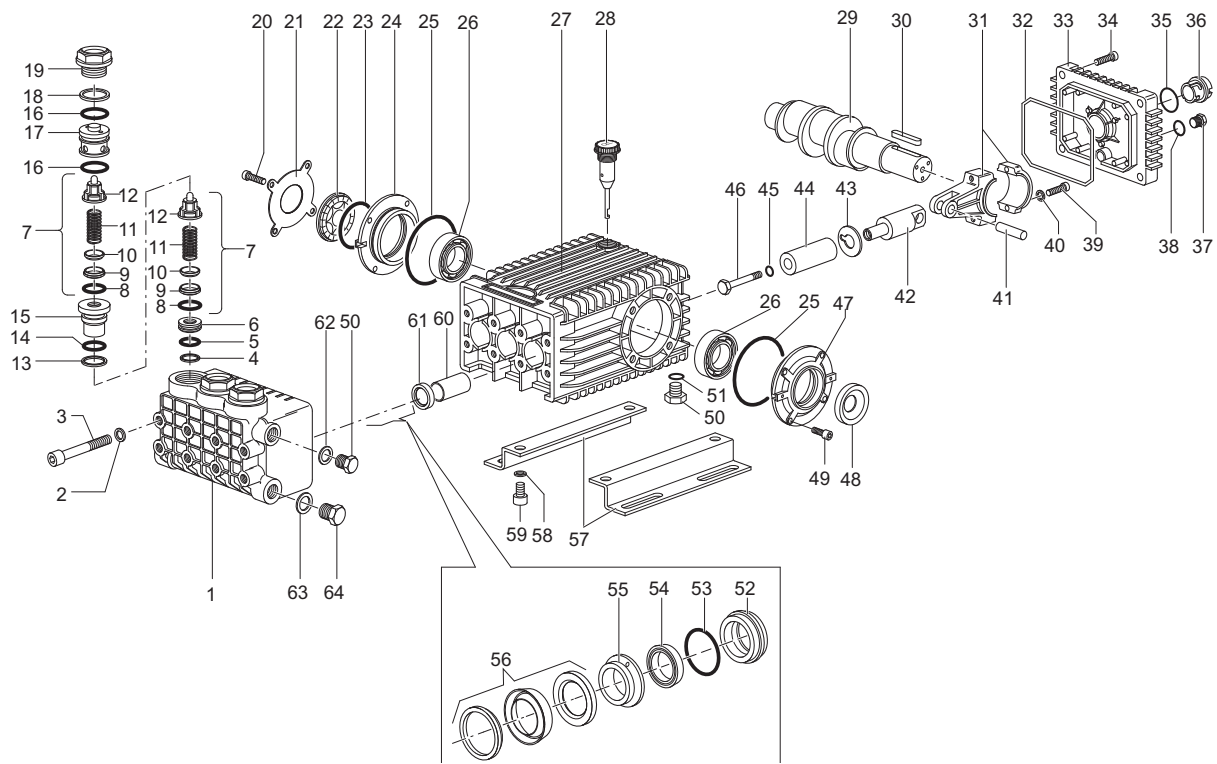

TORQUE SPECS*

| Item | N-M | Ft-lbs |
|------|-----|--------|
| 3 | 45 | 33.2 |
| 19 | 130 | 95.9 |
| 20 | 20 | 14.8 |
| 34 | 10 | 7.4 |
| 37 | 20 | 14.8 |
| 39 | 20 | 14.8 |
| 46** | 20 | 14.8 |
| 49 | 20 | 14.8 |
| 50 | 40 | 29.5 |
| 59 | 40 | 29.5 |

** Use Loc-tite 542

Water Pump TSP1821

| ITEM | QTY. | PART # | DESCRIPTION | ITEM | QTY. | PART # | DESCRIPTION |
|------|------|------------|--------------------------|------|------|------------|-----------------------------|
| 1 | 1 | 8047240-1 | MANIFOLD | 57 | 2 | 8047240-57 | PUMP RAIL |
| 2 | 8 | 8047240-2 | WASHER, M10 | 58 | 4 | 8047240-58 | WASHER M10 |
| 3 | 8 | 8047240-3 | HEADBOLT M10 X 120 | 59 | 4 | 8047240-59 | SCREW M10 X 18 |
| 4 | 3 | 8047240-4 | ANTI-EXT RING | 60 | 3 | 8047240-60 | GUIDE BUSHING |
| 5 | 3 | 8047240-5 | O-RING 18.77 X 1.78 | 61 | 3 | 8047240-61 | SEAL, PL. ROD 22 X 32 X 5.5 |
| 6 | 3 | 8047240-6 | SPACER, M12 | 62 | 1 | 8047240-62 | GASKET, ALUMINUM 3/8" |
| 7 | 6 | 8047240-7 | VALVE, ASSY | 63 | 1 | 8047240-63 | GASKET, ALUMINUM 1/2" |
| 8 | 6 | 8047240-8 | O-RING 18.77 X 1.78 | 64 | 1 | 8047240-64 | PLUG, G1/2" X 10 |
| 9 | 6 | 8047240-9 | VALVE SEAT | | | | |
| 10 | 6 | 8047240-10 | VALVE POPPET | | | | |
| 11 | 6 | 8047240-11 | VALVE SPRING | | | | |
| 12 | 6 | 8047240-12 | VALVE GUIDE | | | | |
| 13 | 3 | 8047240-13 | ANTI-EXT RING | | | | |
| 14 | 3 | 8047240-14 | O-RING 17.86 X 2.62 | | | | |
| 15 | 3 | 8047240-15 | BUSHING | | | | |
| 16 | 6 | 8047240-16 | O-RING 23.81 X 2.62 | | | | |
| 17 | 3 | 8047240-17 | PLUG, 19MM | | | | |
| 18 | 3 | 8047240-18 | ANTI-EXT RING | | | | |
| 19 | 3 | 8047240-19 | VALVE CAP | | | | |
| 20 | 4 | 8047240-20 | SCREW, M8 X 25 | | | | |
| 21 | 1 | 8047240-21 | COVER | | | | |
| 22 | 1 | 8047240-22 | SPACER, SIGHTGLASS | | | | |
| 23 | 1 | 8047240-23 | O-RING 55.56 X 3.53 | | | | |
| 24 | 2 | 8047240-24 | SIDE COVER | | | | |
| 25 | 2 | 8047240-25 | O-RING 67.95 X 2.62 | | | | |
| 26 | 1 | 8047240-26 | BEARING | | | | |
| 27 | 1 | 8047240-27 | CRANKCASE | | | | |
| 28 | 1 | 8047240-28 | DIPSTICK, VENTED | | | | |
| 29 | 1 | 8047240-29 | CRANKSHAFT TSP1821 | | | | |
| 30 | 1 | 8047240-30 | KEY | | | | |
| 31 | 3 | 8047240-31 | CONNECTING ROD | | | | |
| 32 | 1 | 8047240-32 | O-RING 133.02 X 2.62 | | | | |
| 33 | 1 | 8047240-33 | COVER, CRANKCASE | | | | |
| 34 | 4 | 8047240-34 | SCREW, M6 X 20 | | | | |
| 35 | 1 | 8047240-35 | O-RING 26.58 X 3.53 | | | | |
| 36 | 1 | 8047240-36 | SIGHTGLASS BAYONET STYLE | | | | |
| 37 | 1 | 8047240-37 | PLUG, G 1/4" X 9 | | | | |
| 38 | 1 | 8047240-38 | O-RING 10.82 X 1.78 | | | | |
| 39 | 6 | 8047240-39 | SCREW M8 X 35 | | | | |
| 40 | 6 | 8047240-40 | LOCKING WASHER M8 | | | | |
| 41 | 3 | 8047240-41 | WRIST PIN | | | | |
| 42 | 3 | 8047240-42 | PISTON GUIDE | | | | |
| 43 | 3 | 8047240-43 | FLINGER WASHER | | | | |
| 44 | 3 | 8047240-44 | PLUNGER 18 X 54 | | | | |
| 45 | 3 | 8047240-45 | O-RING 10.82 X 1.78 | | | | |
| 46 | 3 | 8047240-46 | PLUNGER BOLT | | | | |
| 47 | 1 | 8047240-47 | SIDE COVER, PTO | | | | |
| 48 | 1 | 8047240-48 | SEAL SHAFT 30 X 55 X 7 | | | | |
| 49 | 4 | 8047240-49 | SCREW M8 X 16 | | | | |
| 50 | 2 | 8047240-50 | PLUG 3/8 X 13 | | | | |
| 51 | 1 | 8047240-51 | O-RING 13.95 X 2.62 | | | | |
| 52 | 3 | 8047240-52 | SEAL RETAINER | | | | |
| 53 | 3 | 8047240-53 | O-RING 34.65 X 1.78 | | | | |
| 54 | 3 | 8047240-54 | LP SEAL | | | | |
| 56 | 3 | 8047240-55 | INTERMEDIATE RING | | | | |

| | ITEM #S | NO. OF ASSY | NO. OF CYL KIT |
|----------------|---|-------------|----------------|
| | INCL'D IN KIT | IN KIT | WILL SERVICE |
| KIT # | | | |
| 8047240-K02 | 61 | 3 | 3 |
| 8047240-K03 | 48 | 1 | 0 |
| 8047240-K15066 | 8,9,10,11,12 11,12,13,14 16,18(7) | 6 | 3 |
| 8047240-K174 | 54,56 | 3 | 3 |
| 8047240-K175 | 52,53,54,55,56 | 1 | 1 |
| 8047240-K180 | 54,56 | 3 | 3 |
| 8047240-K176 | 52,53,54,55,56 | 1 | 1 |

061411-E

VACASSY335

Water Pump Assembly

TSF2021
8GPM
3600PSI

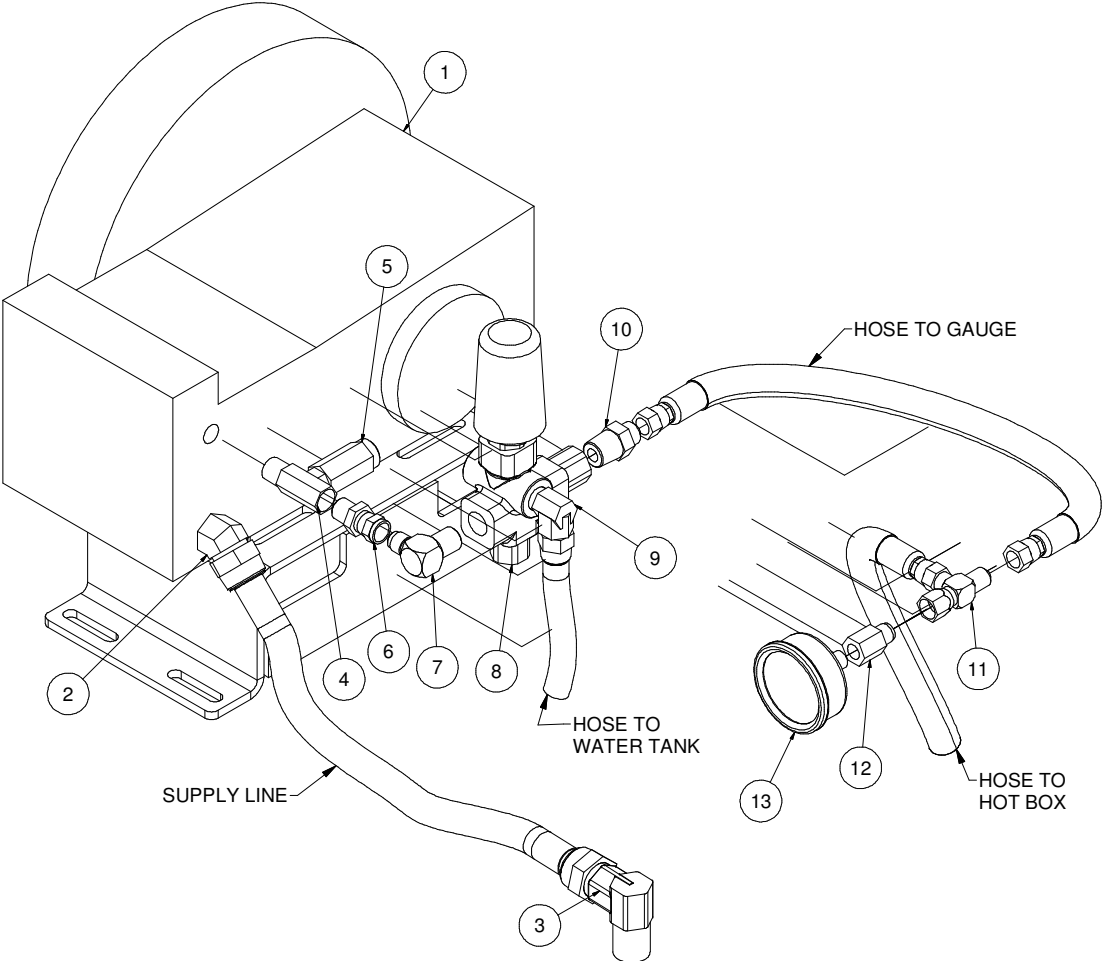

Water Pump Assembly

**TSF2021
8GPM
3600PSI**

| ITEM | QTY | PART NO. | DESCRIPTION |
|------|-----|----------|------------------------------|
| 1 | 1 | 8047941 | WATER PUMP |
| | 4 | U000420 | SCREW, HC 3/8"-16 X 1" |
| | 4 | U210060 | WASHER, LOCK 3/8" |
| | 4 | U200600 | WASHER, FLAT 3/8" |
| | 1 | 8047241 | WATER PUMP CLUTCH |
| | 2 | 8049163 | BELT BP59 |
| 2 | 1 | T401561 | ELBOW, 45 1/2MP - 3/4MJ |
| 3 | 1 | T401180 | ELBOW, 90 3/4MP - 3/4MJ |
| 4 | 1 | T402175 | TEE, 3/8FP - 3/8FP - 3/8MP |
| 5 | 1 | 8030340 | VALVE, RELIEF |
| 6 | 1 | T400813 | UNION, 6MP - 6FJ |
| 7 | 1 | T401102 | ELBOW, 90 6MJ - 6MP |
| 8 | 1 | 8047993 | VALVE, REGULATOR PULSAR 4KHP |
| 9 | 1 | T401120 | ELBOW, 90 3/8MP - 3/8MJ |
| 10 | 1 | T400028 | UNION, 3/8MP - 3/8MJ |
| 11 | 1 | T402153 | TEE, 6MJ - 6MJ - 6FJ |
| 12 | 1 | 8031126 | REDUCER, 1/4FP - 3/8MJ |
| 13 | 1 | 8030372 | WATER PRESSURE GAUGE 1/4NPT |

* NOT SHOWN

040813-E

VACASSY336

Water Pump TSF2021

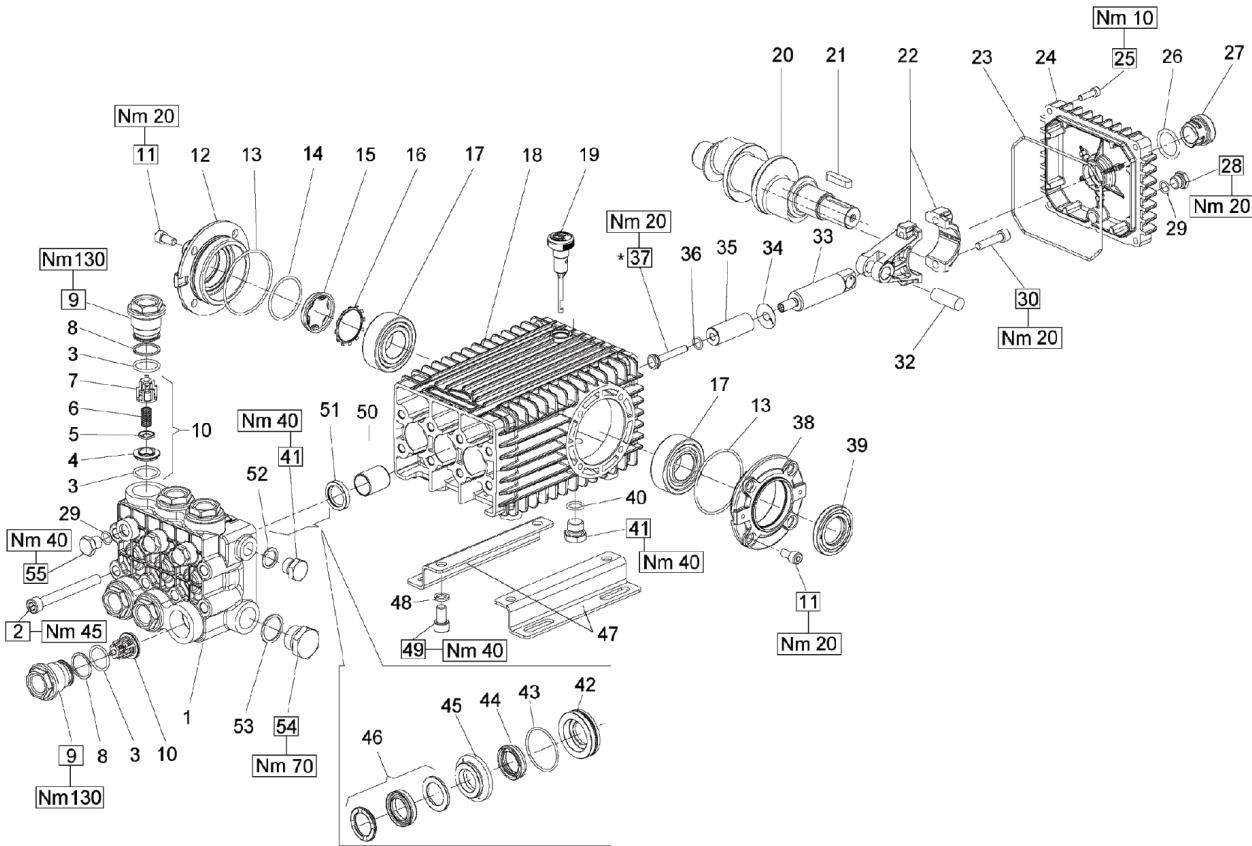

TORQUE SPECS*

*Decrease torque by 20%
if threads are lubricated

| POS. | Nm | Ft/lb |
|------|-----|-------|
| 2 | 45 | 33.2 |
| 9 | 130 | 95.9 |
| 11 | 20 | 14.8 |
| 25 | 10 | 7.4 |
| 28 | 20 | 14.8 |
| 30 | 20 | 14.8 |
| 37** | 20 | 14.8† |
| 41 | 40 | 29.5 |
| 49 | 40 | 29.5 |
| 54 | 70 | 51.6 |
| 55 | 40 | 29.5 |

VACASSY337

Water Pump TSF2021

| ITEM | QTY. | PART # | DESCRIPTION |
|------|------|------------|-------------------------------|
| 1 | 1 | 8047941-1 | Manifold, 20mm |
| 2 | 8 | 8047941-2 | Headbolt, M10 x 90 |
| 3 | 12 | 8047941-3 | O-ring, 23.81 x 2.62 |
| 4 | 6 | 8047941-4 | Seat, Valve |
| 5 | 6 | 8047941-5 | Seat, Poppet |
| 6 | 6 | 8047941-6 | Valve Spring 10 x 18 x 18.5 |
| 7 | 6 | 8047941-7 | Guide, Valve |
| 8 | 6 | 8047941-8 | Anti-ext ring 24.7 x 29 x 1.5 |
| 9 | 6 | 8047941-9 | Plug, M32 x 1.5 x 29.5 |
| 10 | 6 | 8047941-10 | Valve Assembly Complete |
| 11 | 8 | 8047941-11 | Screw, M8 x 16 |
| 12 | 1 | 8047941-12 | Cover |
| 13 | 2 | 8047941-13 | O-ring, 67.95 x 2.62 |
| 14 | 1 | 8047941-14 | O-ring, 39.34 x 2.62 |
| 15 | 1 | 8047941-15 | Oil Sight Glass |
| 16 | 1 | 8047941-16 | Retainer Clip |
| 17 | 2 | 8047941-17 | Bearing |
| 18 | 1 | 8047941-18 | Crankcase |
| 19 | 1 | 8047941-19 | Dip Stick |
| 20 | 1 | 8047941-20 | Crankshaft, 19mm Stroke |
| 21 | 1 | 8047941-21 | Key, 9 x 7 x 35 |
| 22 | 3 | 8047941-22 | Connecting Rod, Complete |
| 23 | 1 | 8047941-23 | O-ring 133.02 x 2.62 |
| 24 | 1 | 8047941-24 | Rear Cover |
| 25 | 4 | 8047941-25 | Screw, M6 x 20 |
| 26 | 1 | 8047941-26 | O-ring 26.58 x 3.53 |
| 27 | 1 | 8047941-27 | Oil Indicator |
| 28 | 1 | 8047941-28 | Plug, G1/4" x 9 |
| 29 | 4 | 8047941-29 | O-ring .426 x .070 |
| 30 | 6 | 8047941-30 | Screw, M8 x 35 |
| 32 | 3 | 8047941-32 | Wrist Pin, 14 x 39 |
| 33 | 3 | 8047941-33 | Pisten Guide |
| 34 | 3 | 8047941-34 | Flinger Washer |
| 35 | 3 | 8047941-35 | Plunger (20 mm) |
| 37 | 3 | 8047941-37 | Screw, Plunger |
| 38 | 1 | 8047941-38 | Side Cover |
| 39 | 1 | 8047941-39 | Seal Shaft |
| 40 | 1 | 8047941-40 | O-ring, 13.95 x 2.62 |
| 41 | 2 | 8047941-41 | Plug 3/8 x 13 |
| 42 | 3 | 8047941-42 | Seal Retainer 20mm |
| 43 | 3 | 8047941-43 | O-ring, 34.65 x 1.78 |
| 44 | 3 | 8047941-44 | LP Seal 20mm |
| 45 | 3 | 8047941-45 | Intermed. Ring 20mm |
| 46 | 3 | 8047941-46 | HP Seal 20mm |
| 47 | 2 | 8047941-47 | Pump Rail |
| 48 | 4 | 8047941-48 | Washer M10 |
| 49 | 4 | 8047941-49 | Screw, M10 x 18 |
| 50 | 3 | 8047941-50 | Guide Bushing |
| 51 | 3 | 8047941-51 | Seal, Plunger Rod |
| 52 | 1 | 8047941-52 | Gasket, Al. 3/8" |
| 53 | 1 | 8047941-53 | Washer |
| 54 | 1 | 8047941-54 | Plug, G3/4" x 16 |
| 55 | 3 | 8047941-55 | Plug 1/4" x 13 |

| KIT # | ITEM #'S INCL'D IN KIT | NO. OF ASSY IN KIT | NO. OF CYL KIT WILL SERVICE |
|----------------|---------------------------|-----------------------|--------------------------------|
| 8047941-KIT170 | 44, 46 | 3 | 3 |
| 8047941-KIT171 | 42,43,44,45,46 | 1 | 1 |

VACASSY337

Unloader Valve PULSAR3KHP

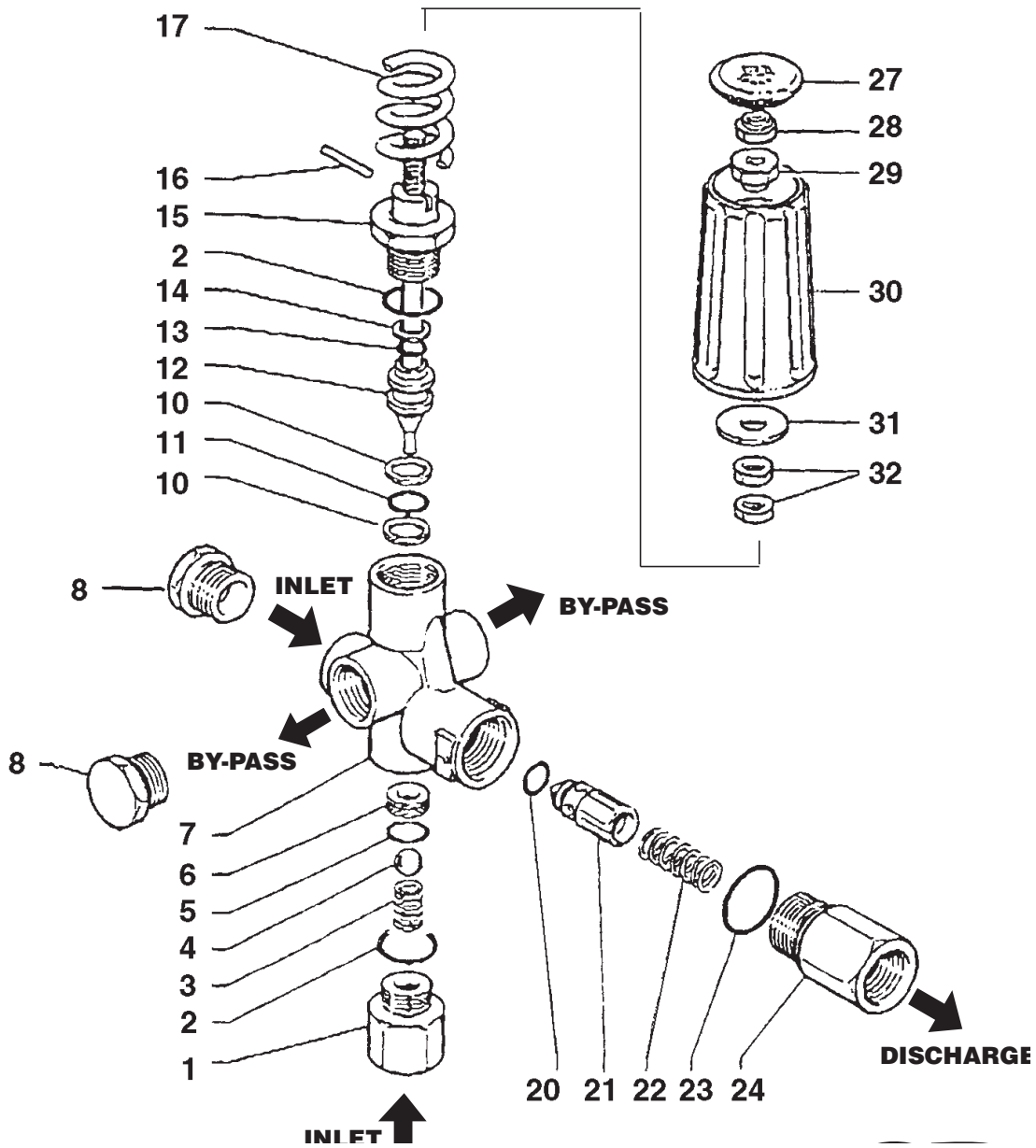

050409

VACASSY328

Unloader Valve PULSAR3KHP

| ITEM | QTY | PART # | DESCRIPTION |
|------|-----|------------|--------------------------|
| 1 | 1 | 8040177-1 | INLET FITTING, 3/8 NPT-F |
| 2 | 2 | 8040177-2 | O-RING, .676ID X .070CS |
| 3 | 1 | 8040177-3 | BALL SPRING |
| 4 | 1 | 8040177-4 | SS BALL, 13/32 |
| 5 | 1 | 8040177-5 | O-RING, .437ID X .070CS |
| 6 | 1 | 8040177-6 | SS SEAT, .551OD X .335ID |
| 7 | 1 | 8040177-7 | BRASS BODY, 3/8 NPT |
| 8 | 2 | 8040177-8 | PLUG, 3/8"NPT |
| 10 | 2 | 8040177-10 | BACKUP RING |
| 11 | 1 | 8040177-11 | O-RING, .424ID X .103CS |
| 12 | 1 | 8040177-12 | SS PISTON |
| 13 | 1 | 8040177-13 | OORING, .299ID X .103CS |
| 14 | 1 | 8040177-14 | BACKUP RING |
| 15 | 1 | 8040177-15 | PISTON HOUSING |
| 16 | 1 | 8040177-16 | LOCKING PIN |
| 17 | 1 | 8040177-17 | BLUE SPRING |
| 20 | 1 | 8040177-20 | O-RING, .236ID X .118CS |
| 21 | 1 | 8040177-21 | CHECK VALVE |
| 22 | 1 | 8040177-22 | SS SPRING |
| 23 | 1 | 8040177-23 | O-RING, .739ID X .070CS |
| 24 | 1 | 8040177-24 | OUTLET FITTING, 3/8NPT-F |
| 27 | 1 | 8040177-27 | PLASTIC PLUG for KNOB |
| 28 | 1 | 8040177-28 | ZINC NUT, M8 |
| 29 | 1 | 8040177-29 | INSERT M8 |
| 30 | 1 | 8040177-30 | PLASTIC KNOB |
| 31 | 1 | 8040177-31 | WASHER, 9mm X 24mm |
| 32 | 2 | 8040177-32 | BRASS NUT, M8 |

Unloader Valve YU5075K

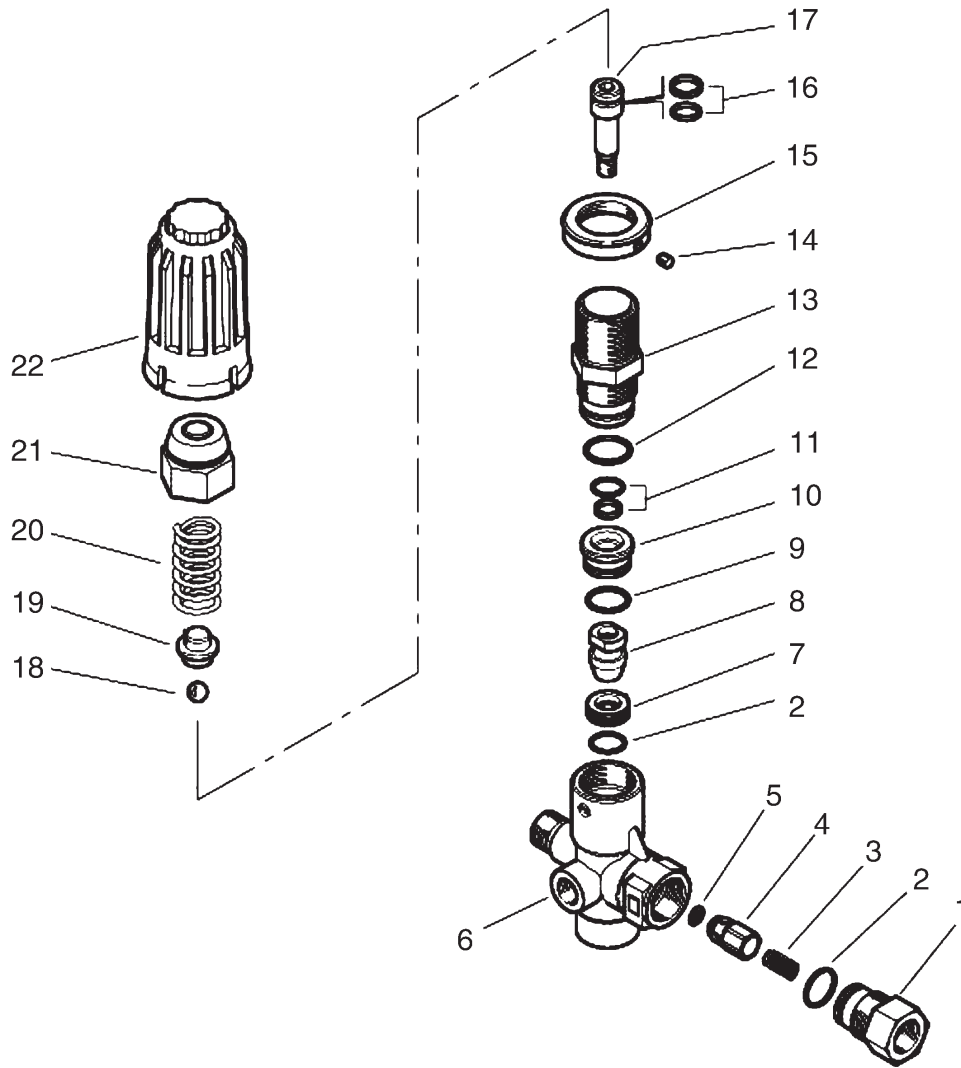

Unloader Valve YU5075K

| ITEM | QTY | PART # | DESCRIPTION |
|------|-----|------------|------------------------------|
| 1 | 1 | 8047275-1 | 3/8" BSP F NIPPLE |
| 2 | 2 | 8047275-2 | O-RING, 1.78 X 15.6 |
| 3 | 1 | 8047275-3 | SPRING |
| 4 | 1 | 8047275-4 | S.S. CHECK VALVE |
| 5 | 1 | 8047275-5 | O-RING, 3 X 6 MM |
| 6 | 1 | 8047275-6 | VALVE BODY |
| 7 | 1 | 8047275-7 | SEAT |
| 8 | 1 | 8047275-8 | M8 SHUTTER |
| 9 | 1 | 8047275-9 | O-RING, 1.78 X 17.17MM |
| 10 | 1 | 8047275-10 | SPACER |
| 11 | 1 | 8047275-11 | VALVE PISTON SEAL REPAIR SET |
| 12 | 1 | 8047275-12 | O-RING, 1.78" X 20.35 |
| 13 | 1 | 8047275-13 | PISTON HOUSING |
| 14 | 1 | 8047275-14 | M4 X 4MM DOWL |
| 15 | 1 | 8047275-15 | LOCK RING |
| 16 | 1 | 8047275-16 | PISTON SEAL REPAIR KIT |
| 17 | 1 | 8047275-17 | M8 PISTON |
| 18 | 1 | 8047275-18 | S.S. 11/32" BALL |
| 19 | 1 | 8047275-19 | SPRING GUIDE |
| 20 | 1 | 8047275-20 | 4.5 X 47MM SPRING |
| 21 | 1 | 8047275-21 | BRASS CAP |
| 22 | 1 | 8047275-22 | RED PLASTIC CAP |

Unloader Valve YU2140

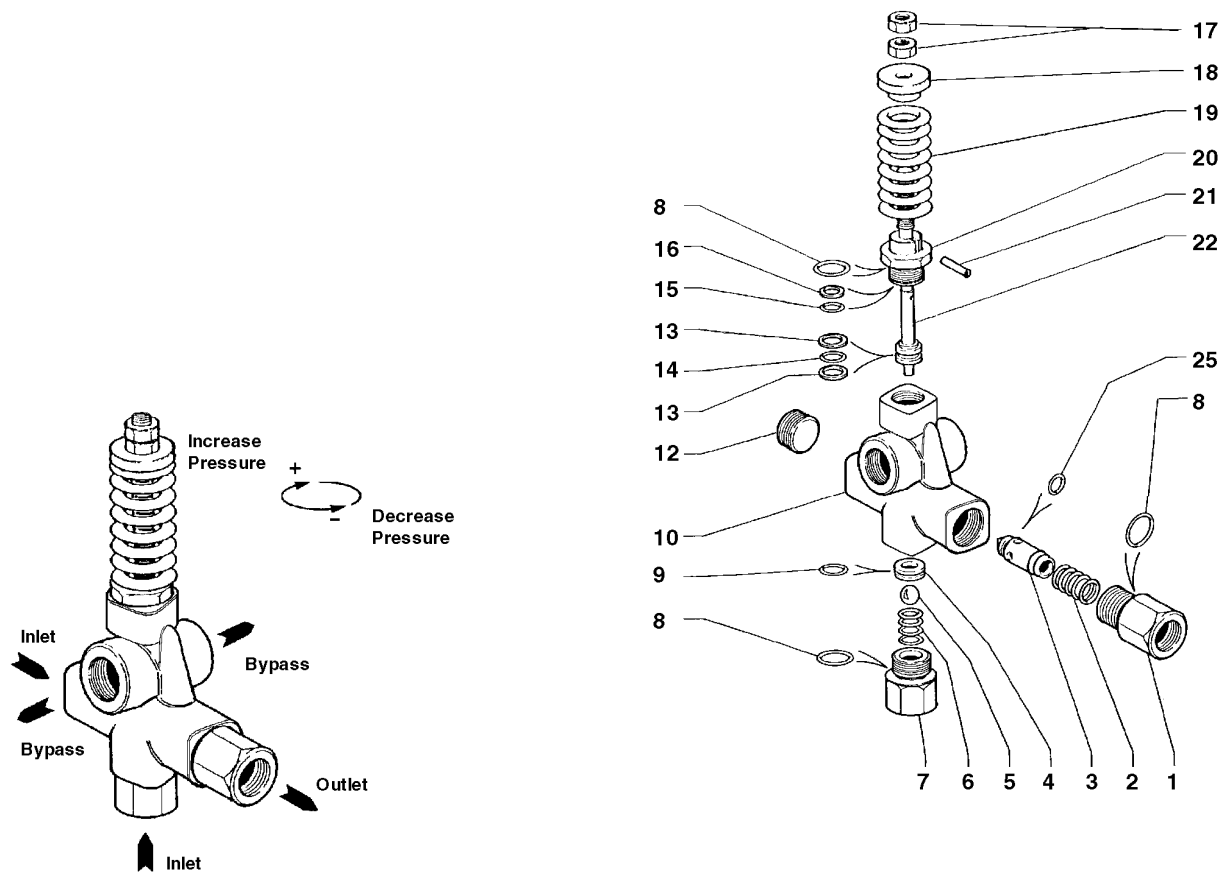

072908

VACASSY326

Unloader Valve YU2140

| ITEM | QTY | PART # | DESCRIPTION |
|------|-----|------------|-----------------------|
| 1 | 1 | 8030341-1 | OUTLET CONNECTION |
| 2 | 1 | 8030341-2 | SPRING |
| 3 | 1 | 8030341-3 | CHECK VALVE |
| 4 | 1 | 8030341-4 | SEAT |
| 5 | 1 | 8030341-5 | SS BALL |
| 6 | 1 | 8030341-6 | SPRING |
| 7 | 1 | 8030341-7 | INLET CONNECTION |
| 8 | 2 | 8030341-8 | O-RING |
| 9 | 1 | 8030341-9 | O-RING |
| 10 | 1 | 8030341-10 | VALVE HOUSING |
| 12 | 1 | 8030341-12 | PLUG |
| 13 | 2 | 8030341-13 | BACK RING |
| 14 | 1 | 8030341-14 | O-RING |
| 15 | 1 | 8030341-15 | O-RING |
| 16 | 1 | 8030341-16 | BACK RING |
| 17 | 1 | 8030341-17 | NUT |
| 18 | 1 | 8030341-18 | SPRING GUIDE |
| 19 | 1 | 8030341-19 | SPRING-GREEN (YU2140) |
| 20 | 1 | 8030341-20 | PISTON HOUSING |
| 21 | 1 | 8030341-21 | PIN |
| 22 | 1 | 8030341-22 | PISTON |
| 25 | 1 | 8030341-25 | O-RING |

Electrical Control Bracket

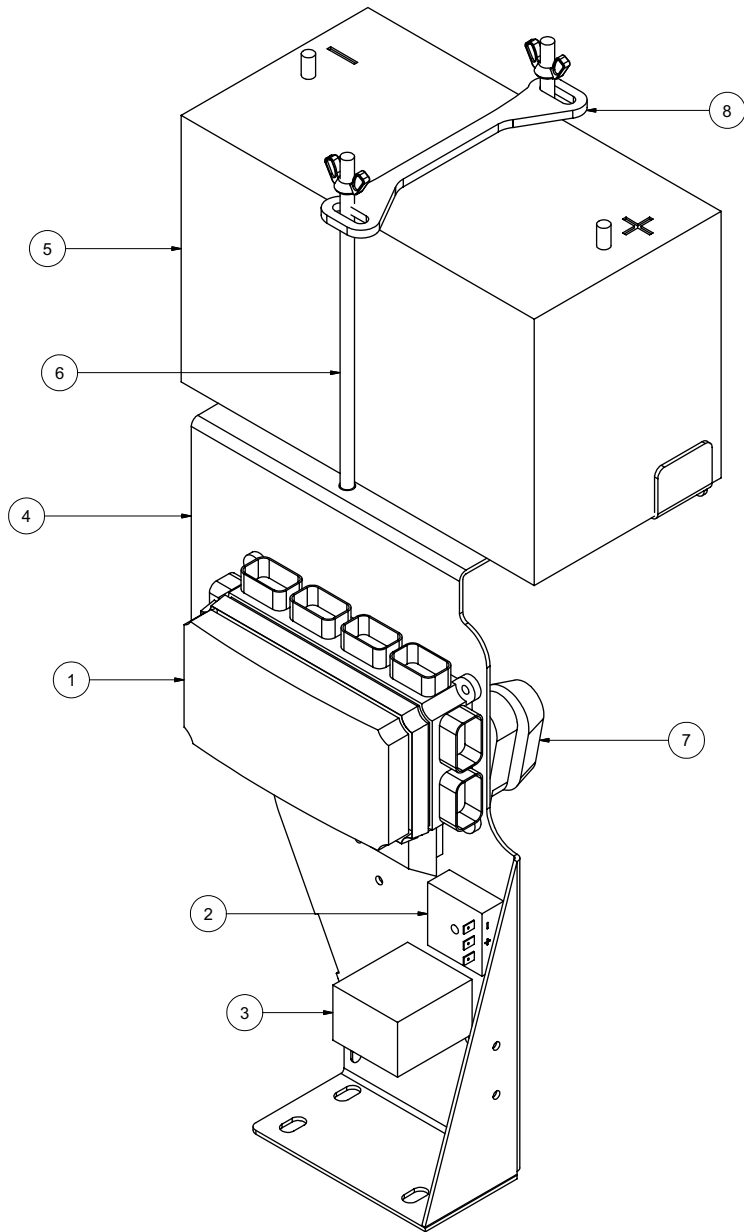

012813-E

VACASSY550

Electrical Control Bracket

| ITEM | QTY | PART NO. | DESCRIPTION |
|------|-----|----------|-----------------------------------|
| 1 | 1 | X000239 | BUSSMAN VEC |
| | 7 | X000205 | FUSE 5A |
| | 2 | X000206 | FUSE 10A |
| | 2 | X000207 | FUSE 20A |
| | 3 | X000237 | FUSE 30A |
| | 1 | X000236 | CIRCUIT BREAKER 20A |
| | 1 | X000210 | CIRCUIT BREAKER 30A |
| | 6 | X000209 | RELAY 35A/25A |
| | 5 | X000208 | DIODE 6A |
| * | 4 | U000040 | SCREW, HC 1/4" - 20 X .750 |
| * | 4 | U200020 | WASHER, FLAT 1/4" |
| * | 4 | U210020 | WASHER, LOCK 1/4" |
| * | 4 | U100020 | NUT, HEX 1/4"-20 |
| 2 | 1 | 8042282 | SWITCH, DELAY RELAY |
| * | 1 | U100020 | NUT, HEX 1/4"-20 |
| | 1 | U200020 | WASHER, FLAT 1/4" |
| | 1 | U210020 | WASHER, LOCK 1/4" |
| | 1 | U000080 | SCREW, HC 1/4"-20 X 1.25 ZP G5 |
| 3 | 1 | X000241 | RELAY TIMER 15 SEC SHUTDOWN |
| * | 1 | U100020 | NUT, HEX 1/4"-20 |
| | 1 | U200020 | WASHER, FLAT 1/4" |
| | 1 | U210020 | WASHER, LOCK 1/4" |
| | 1 | U000080 | SCREW, HC 1/4"-20 X 1.25 ZP G5 |
| 4 | 1 | 8043127 | CONTROL PANEL - HARNESS MTG PLATE |
| 5 | 1 | X400050 | BATTERY, 31-MHD WORKAHOLIC |
| 6 | 2 | 8043742 | BATTERY HOLD DOWN ROD ASSY |
| 7 | 1 | 8043800 | FUSE HOLDERAMG |
| | 1 | 8043801 | FUSE 250A AMG |
| * | 2 | U000060 | SCREW, HC 1/4"-20 X 1.00 |
| * | 2 | U200020 | WASHER, FLAT 1/4" |
| * | 2 | U210020 | WASHER, LOCK 1/4" |
| * | 2 | U100020 | NUT, HEX 1/4"-20 |
| 8 | 1 | 8050016 | BATTERY HOLD DOWN |
| * | 1 | X200005 | HARNESS VAC CONTROL |

* NOT SHOWN

Control Panel

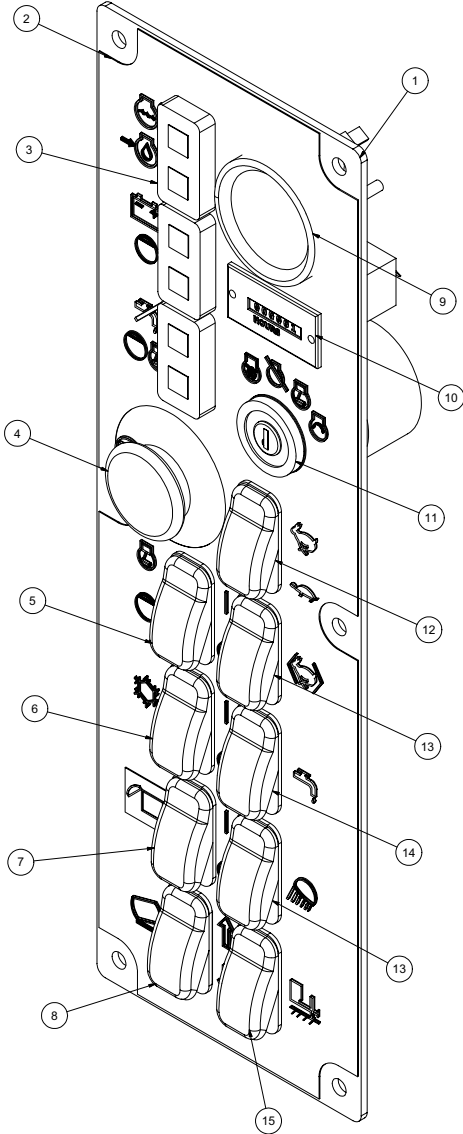
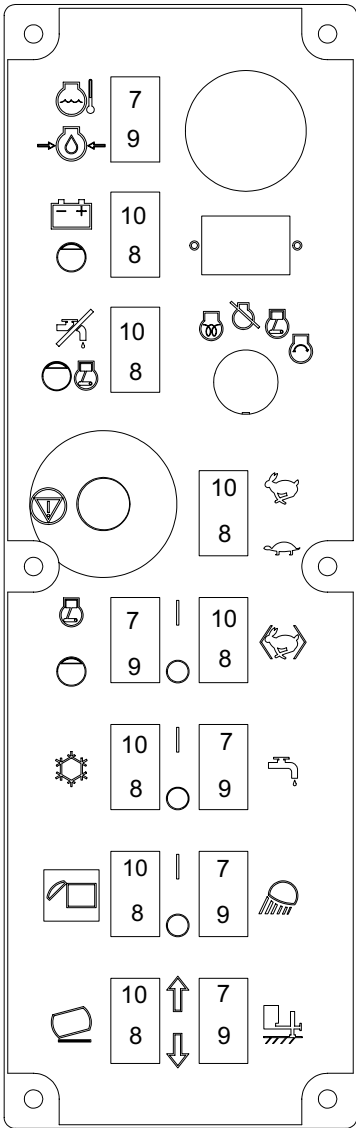

Control Panel

| ITEM | QTY | PART NO. | DESCRIPTION |
|------|-----|----------|---------------------------------------|
| 1 | 1 | 8043128 | CONTROL PANEL - MAIN PLATE |
| 2 | 1 | J200031 | DECAL - CONTROL PANEL |
| 3 | 3 | X000260 | LIGHT LED DUAL PANEL |
| 4 | 1 | X000280 | E-STOP |
| 5 | 1 | X000273 | ROCKER SWITCH SPST (ON) NONE -OFF |
| 6 | 1 | X000271 | ROCKER SWITCH DPST (ON) NONE -ON |
| 7 | 1 | X000274 | ROCKER SWITCH DPST (ON) OFF (ON) |
| 8 | 1 | X000274 | ROCKER SWITCH DPDT (ON) OFF (ON) |
| 9 | 1 | X100001 | FUEL GAUGE |
| 10 | 1 | X000300 | HOUR METER |
| 11 | 1 | 8030458 | IGNITION SWITCH |
| 12 | 1 | X000271 | ROCKER SWITCH DPST ON - ON |
| 13 | 2 | X000270 | ROCKER SWITCH SPST ON -OFF |
| 14 | 1 | X000270 | ROCKER SWITCH SPST ON -OFF |
| | 1 | X000271 | ROCKER SWITCH DPST ON -ON |
| 15 | 1 | X000290 | ROCKER SWITCH PLUG |
| | 1 | X000274 | ROCKER SWITCH DPDT (HYD. JACK OPTION) |
| * | 1 | 8030829 | KEY, IGNITION - KUBOTA |

* NOT SHOWN

Boom Hydraulics Assembly

67HP/99HP

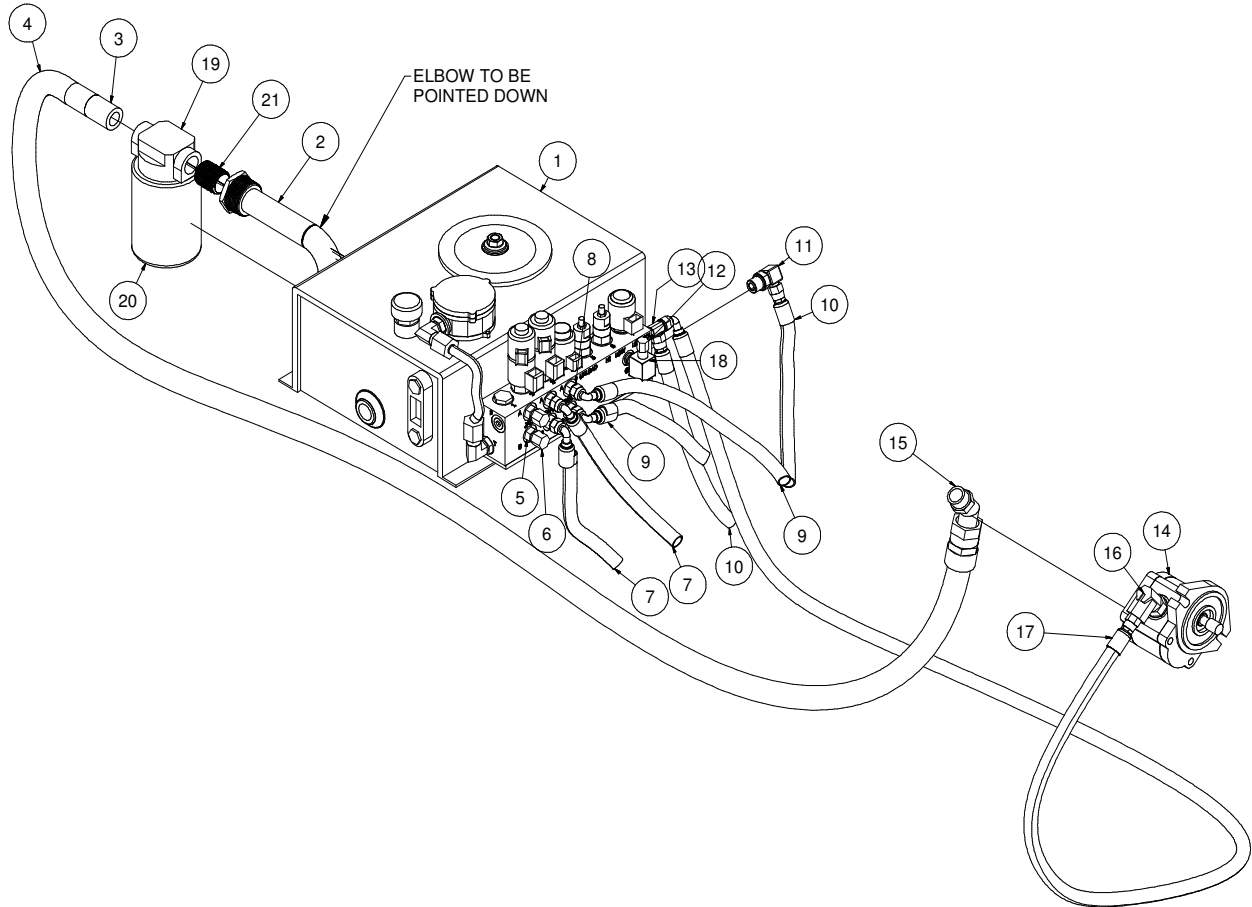

103012-E

VACASSY998

Boom Hydraulics Assembly

67HP/99HP

| ITEM | QTY | PART | DESCRIPTION |
|------|-----|---------|-------------------------------------|
| 1 | 1 | 8047330 | KIT, HYD. BOOM BASE PACK (CROSS2) |
| 2 | 1 | 8011058 | SUCTION STRAINER 1" / 15GPM |
| 3 | 1 | 8043963 | UNION, 1"MP - 1"BARB |
| 4 | 1 | 8047786 | HOSE VAC PUSH 1" - 52"LG |
| 5 | 4 | T400037 | UNION, 6MB - 6MJ |
| 6 | 2 | T405203 | CAP, 3/8" FEM. JIC, HEX HEAD |
| 7 | 2 | 8043782 | HOSE ASSY VAC 6 - 77" ST-90 (99HP) |
| 8 | 2 | T400550 | REDUCER, 3/8"MB - 1/4"MJ |
| 9 | 2 | 8047787 | HOSE ASSY VAC 4 - 133" ST-90 (99HP) |
| 10 | 2 | 8047788 | HOSE ASSY VAC 6 - 200" ST-ST (99HP) |
| 11 | 1 | T401250 | ELBOW, 90 3/8"MB - 3/8"MJ |
| 12 | 1 | T405200 | CAP, 1/4" FEM. JIC, HEX HEAD |
| 13 | 1 | T402148 | TEE, 6MB - 6MJ - 6MJ |
| 14 | 1 | 8047333 | PUMP, HYD BOOM 67/99HP (CROSS2) |
| 15 | 1 | 8043964 | ELBOW, 45 16HB - 12MB |
| 16 | 1 | T401290 | ELBOW, 90 5/8"MB - 3/8"MJ |
| 17 | 1 | 8042924 | HOSE ASSY VAC 6-60" ST-ST (99HP) |
| 18 | 1 | T401230 | ELBOW, 90 3/8"MB - 1/4"MJ |

* NOT SHOWN

020612-E

VACASSY998

Boom Hydraulics Assembly

49HP

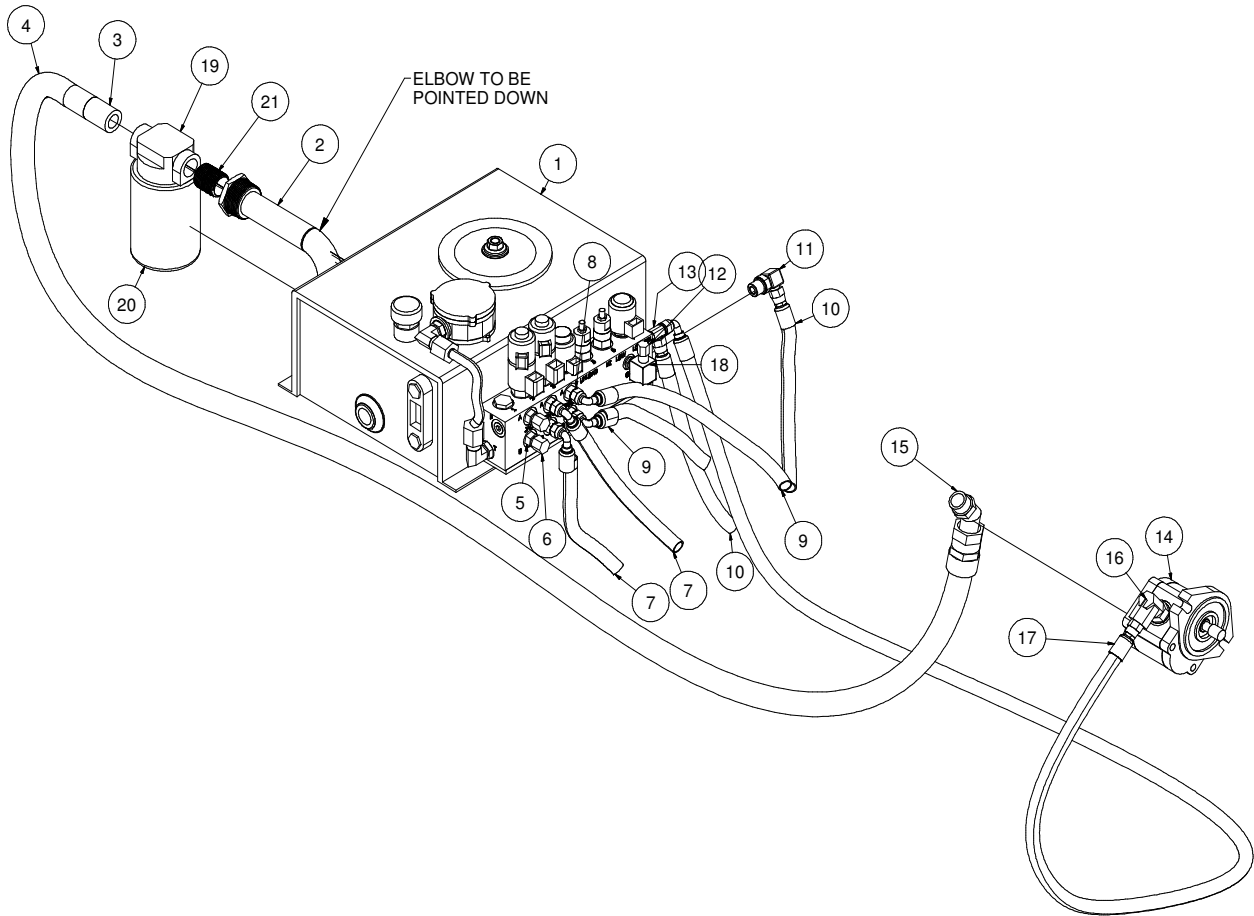

103012-E

VACASSY999

Boom Hydraulics Assembly

49HP

| ITEM | QTY | PART | DESCRIPTION |
|------|-----|---------|-------------------------------------|
| 1 | 1 | 8047330 | KIT, HYD. BOOM BASE PACK (CROSS2) |
| * | 8 | U000440 | WASHER, FLAT 3/8" |
| * | 4 | U000441 | SCREW, HC 3/8"-16 X 1.25" |
| * | 4 | U210061 | NUT, LOCK,NY 3/8" |
| 2 | 1 | 8048348 | FITTING SUCTION 1-1/2"MP W/ELB |
| 3 | 1 | 8043963 | UNION, 1"MP - 1"BARB |
| 4 | 1 | 8047786 | HOSE VAC PUSH 1" - 52"LG |
| 5 | 4 | T400037 | UNION, 6MB - 6MJ |
| 6 | 2 | T405203 | CAP, 3/8" FEM. JIC, HEX HEAD |
| 7 | 2 | 8043782 | HOSE ASSY VAC 6 - 77" ST-90 (99HP) |
| 8 | 2 | T400550 | REDUCER, 3/8"MB - 1/4"MJ |
| 9 | 2 | 8047787 | HOSE ASSY VAC 4 - 133" ST-90 (99HP) |
| 10 | 2 | 8047788 | HOSE ASSY VAC 6 - 200" ST-ST (99HP) |
| 11 | 1 | T401250 | ELBOW, 90 3/8"MB - 3/8"MJ |
| 12 | 1 | T405200 | CAP, 1/4" FEM. JIC, HEX HEAD |
| 13 | 1 | T402148 | TEE, 6MB - 6MJ - 6MJ |
| 14 | 1 | 8047334 | PUMP, HYD BOOM 49HP (CROSS2) |
| 15 | 1 | 8043964 | ELBOW, 45 16HB - 12MB |
| 16 | 1 | T401290 | ELBOW, 90 5/8"MB - 3/8"MJ |
| 17 | 1 | 8042924 | HOSE ASSY VAC 6-60" ST-ST (99HP) |
| 18 | 1 | T401230 | ELBOW, 90 3/8"MB - 1/4"MJ |
| 19 | 1 | 8048346 | STRAINER SUCTION EXT (HEAD) |
| 20 | 1 | 8048347 | STRAINER SUCTION EXT(ELEMENT) |
| 21 | 1 | T421030 | NIPPLE,CLOSE 1"MP |

* NOT SHOWN

Base Manifold Assembly

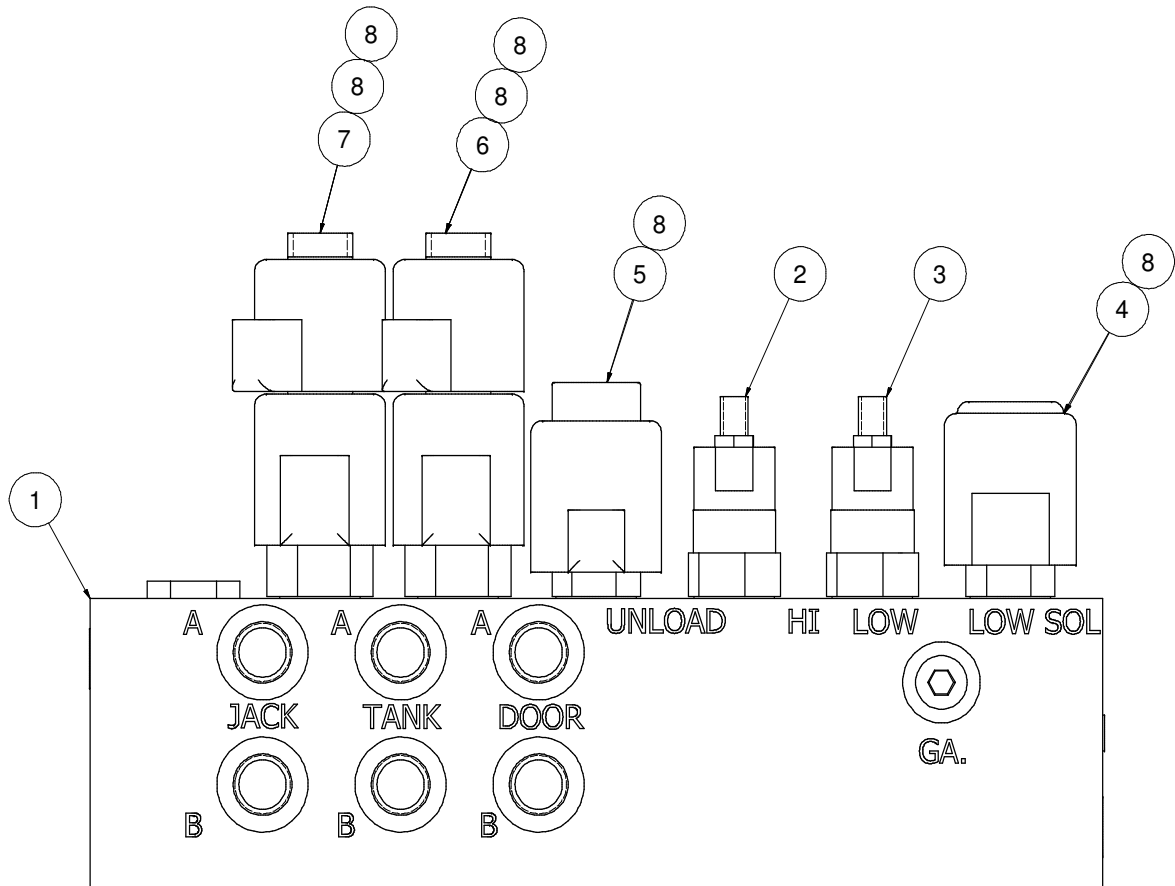

Base Manifold Assembly

| ITEM | QTY | PART | DESCRIPTION |
|------|-----|------------|-----------------------|
| 1 | 1 | 8047330-03 | MANIFOLD BLOCK (ONLY) |
| 2 | 1 | 8047330-12 | HIGH PRESSURE RELIEF |
| 3 | 1 | 8047330-13 | LOW PRESSURE RELIEF |
| 4 | 1 | 8047330-07 | SOL. LOW PRESSURE |
| 5 | 1 | 8047330-08 | SOL. UNLOAD |
| 6 | 1 | 8047330-09 | SOL. DOOR |
| 7 | 1 | 8047330-09 | SOL. TANK |
| 8 | 6 | 8047330-11 | COIL |

* NOT SHOWN

Hydraulic Pump w/ Bracket

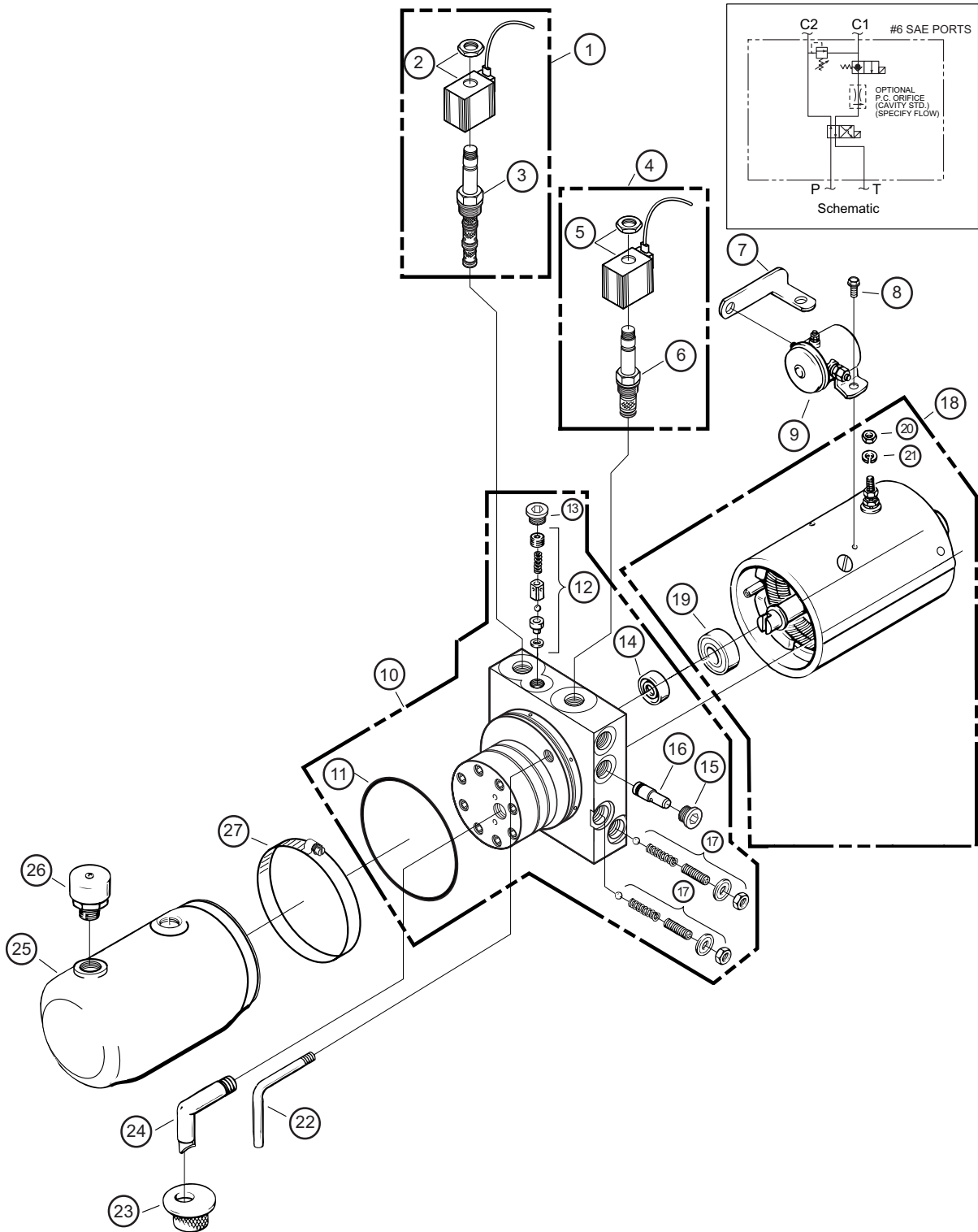

033110-E

VACASSY250

Hydraulic Pump w/ Bracket

| ITEM | QTY | NUMBER | DESCRIPTION |
|------|-----|------------|--|
| | 1 | 8046300 | PUMP, HYD 12V VAC 4.5QT |
| | 2 | U000420 | SCREW, HC 3/8"-16 X 1" |
| | 2 | U210060 | WASHER, LOCK 3/8" |
| | 2 | U200600 | WASHER, FLAT 3/8" |
| | 2 | T400037 | UNION 6MB - 6MJR |
| | 2 | 8040973 | HOSE ASSY VAC 6-20 ST-90 |
| | 2 | T400391 | BULKHEAD 6MP - 6MP |
| 1 | 1 | 8046300-14 | VALVE, 4-WAY - 2 POSITION |
| 2 | 1 | 8046300-15 | COIL, 10VDC GROUNDED W/ DEUTSCH CONN |
| 3 | 1 | 8046300-16 | CARTRIDGE, 4-WAY 2 POSITION |
| 4 | 1 | 8046300-17 | VALVE, 2-WAY 2 POSITION (12V) GROUNDED |
| 5 | 1 | 8046300-18 | COIL, 10VDC 2-WAY 2 POS GRND W/ DEUTSCH CONN |
| 6 | 1 | 8046300-19 | VALVE, 12V HYD 2-WAY 2 POSITION |
| 7 | 1 | 8046300-23 | PUMP ASSEMBLY |
| 8 | 1 | 8046300-24 | O-RING INDUST 3 5/8" X 3 7/8" X 1/8" |
| 9 | 1 | 8046300-25 | PARTS KIT - VALVE ASSY, POPPET/BALL CHECK |
| 10 | 1 | 8046300-26 | PLUG |
| 11 | 1 | 8046300-27 | SEAL |
| 12 | 1 | 8046300-28 | PLUG, #8 SAE |
| 13 | 2 | 8046300-30 | PARTS KIT, RELIEF VALVE |
| 14 | 1 | 8046300-31 | MOTOR, ELECTRIC 12VDC |
| 15 | 1 | 8046300-32 | BEARING, BASE MOTOR |
| 16 | 1 | 8046300-33 | NUT, HEX 5/16 -24 |
| 17 | 1 | 8046300-34 | WASHER, LOCK 5/16" |
| | 2 | 8046300-38 | SCREW, HEX HEAD 1/4"-20 X 1 3/8" |
| | 1 | 8046300-41 | PLUG, 3/8"NPTF |
| 18 | 1 | 8046300-42 | TUBE, RETURN (1/8") |
| 19 | 1 | 8046300-43 | SCREEN, FILTER (SUCTION) |
| 20 | 1 | 8046300-44 | TUBE, FILTER SUCTION 3/8"NPT 90 DEG |
| 21 | 1 | 8046300-45 | 6QT RESEVOIR POLY |
| | * | 8040486-45 | 3QT RESEVOIR POLY |
| | * | 8046300-48 | 4.5QT RESEVOIR POLY |
| 22 | 1 | 8046300-46 | PLUG, VENT 3/8"NPT |
| 23 | 1 | 8046300-47 | CLAMP, HOSE WORM GEAR (IN SERIES) |
| 24 | 1 | 8046258 | SWITCH HYD PUMP 12V |
| | 1 | X200002 | HYDRAULIC PUMP WIRE HARNESS |
| | 1 | 8043499 | HYDRAULIC PUMP MOUNT |
| | | 8044297 | HYDRAULIC PUMP MOUNT (REVERSE FLOW) |
| | | 8045336 | HYDRAULIC PUMP MOUNT (412 BLOWER) |

* NOT SHOWN

Hydraulic Pump Assembly

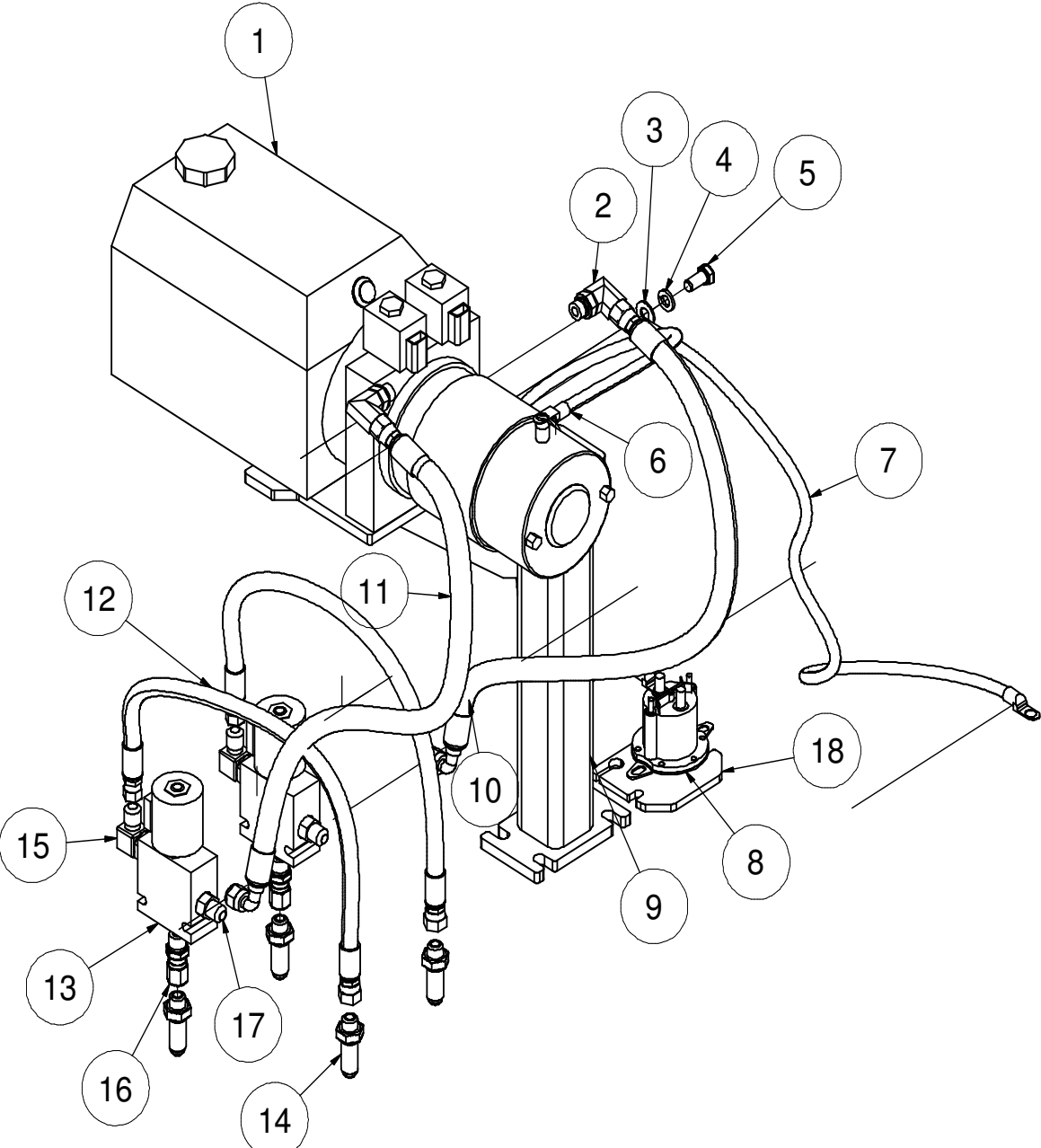

101512-E

VACASSY251

Hydraulic Pump Assembly

| ITEM | QTY | PART | DESCRIPTION |
|------|-----|---------|--|
| 1 | 1 | 8046300 | PUMP, HYD 12V 4.5QT |
| 2 | 2 | T401250 | ELBOW, 90 3/8" MB-MJ |
| 3 | 1 | U200600 | WASHER, FLAT 3/8" |
| 4 | 1 | U210060 | WASHER, LOCK 3/8" |
| 5 | 1 | U200400 | SCREW, HC 3/8"-16 X .750 |
| 6 | 1 | X300233 | CABLE, BATTERY HOT 1GA 26" |
| | 2 | X300251 | LUG, CABLE 1GA 3/8" HOLE |
| 7 | 1 | X300224 | CABLE, BATTERY GROUND 1GA 21" |
| | 2 | X300251 | LUG, CABLE 1GA 3/8" HOLE |
| 8 | 1 | 8046258 | SWITCH HYD PUMP 12V RELOCATE |
| | 2 | U000040 | SCREW, HC 1/4"-20 X .75 ZP G5 |
| | 2 | U200020 | WASHER, FLAT 1/4" ZP |
| | 2 | U210020 | WASHER, LOCK 1/4" ZP |
| | 2 | U100020 | NUT, HEX 1/4"-20 |
| 9 | 1 | 8043499 | BRACKET 36/49 12V HYD PUMP |
| | 1 | 8047283 | BRACKET 99AW HYD PUMP |
| * | 2 | U000460 | SCREW, HC 3/8"-16 X 1.50 ZP G5 |
| * | 2 | U000480 | SCREW, HC 3/8"-16 X 1.75 ZP G5 |
| * | 5 | U200060 | WASHER, FLAT 3/8" |
| * | 5 | U210060 | WASHER, LOCK 3/8" |
| * | 4 | U100060 | NUT, HEX 3/8"-16 |
| * | 1 | U000441 | SCREW, HC 3/8"-16 X 1.25 ZP G8 |
| 10 | 1 | 8046685 | HOSE ASSY VAC 6-25" ST-90 (500LE/LEHD) |
| | 1 | 8046686 | HOSE ASSY VAC 6-22" ST-90 (800LE/LEHD) |
| | 1 | 8040973 | HOSE ASSY VAC 6-20" ST-90 (73/99) |
| 11 | 1 | 8046687 | HOSE ASSY VAC 6-23" ST-90 (500LE/LEHD) |
| | 1 | 8040973 | HOSE ASSY VAC 6-20" ST-90 (800LE/LEHD) |
| | 1 | 8040973 | HOSE ASSY VAC 6-20" ST-90 (73/99) |
| 12 | 2 | 8040971 | HOSE ASSY VAC 4-19" ST-ST6FJ (LE/LEHD) |
| 13 | 2 | 8041788 | VALVE, SOLENOID 3-WAY W/ INT C4K |
| 14 | 4 | T400391 | BULKHEAD 3/8" MJ - 3/8" MJ |
| 15 | 2 | T401250 | ELBOW, 90 3/8" MB - 3/8" MJ |
| 16 | 2 | T400036 | UNION, 3/8" MB - 3/8" FJ |
| 17 | 2 | T400037 | UNION, 3/8" MB - 3/8" MJ |
| 18 | 1 | 8046127 | BRACKET PUMP SOLENOID |

* NOT SHOWN

Water Tank Assembly

125 Gallon Saddle Tanks (Skid)

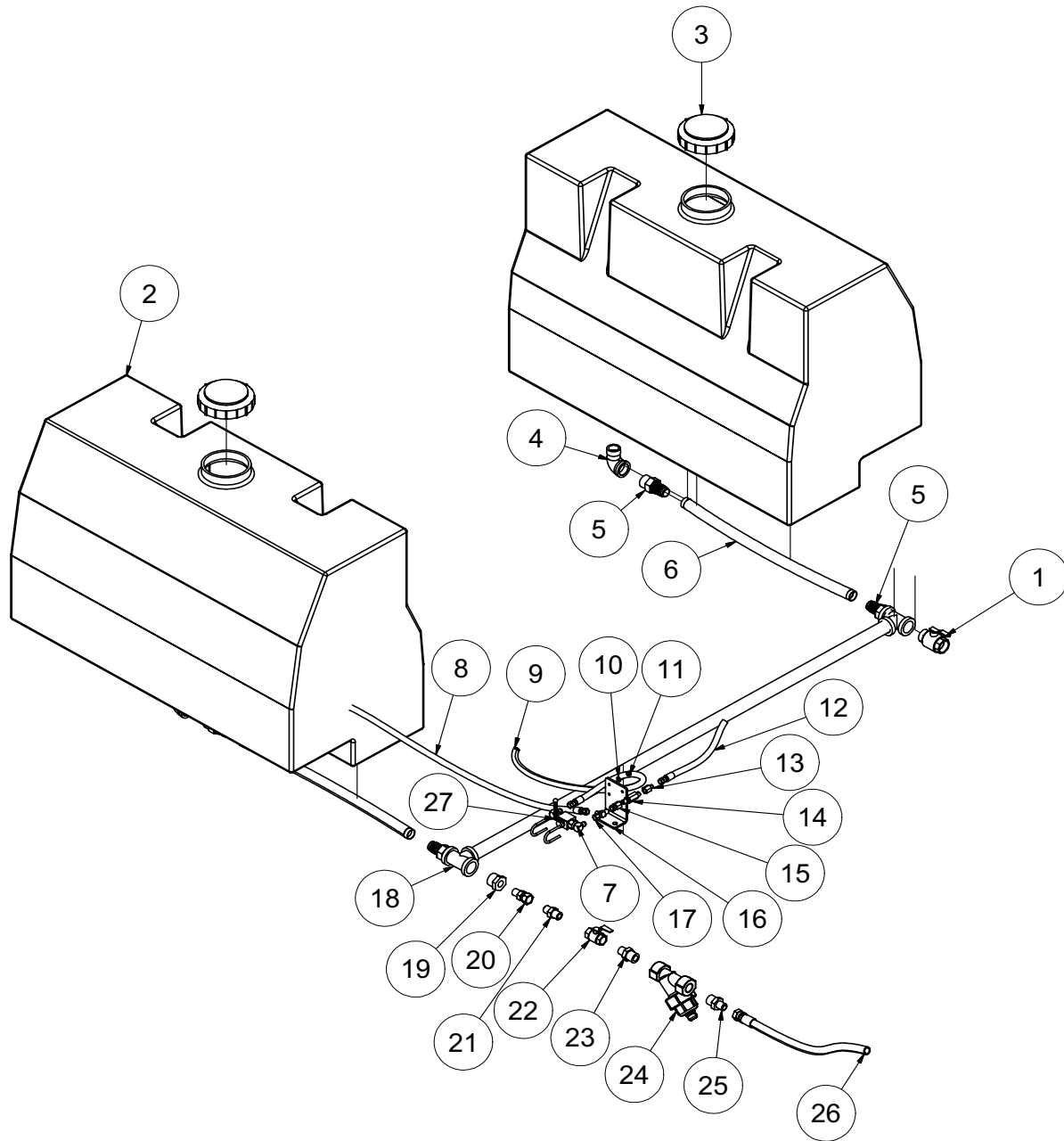

112910-E

VACASSY615

Water Tank Assembly

125 Gallon Saddle Tanks (Skid)

| ITEM | QTY | PART NO. | DESCRIPTION |
|------|-----|-----------|---|
| 1 | 1 | 8045813 | VALVE,BALL 1 1/4" M X F BRASS |
| 2 | 1 | 8046162 | TANK, WATER 125GAL (CURB SIDE) |
| | 1 | 8045093 | BULKHEAD 1 1/4" BOTTOM FEED |
| | 1 | 8040782 | TANK, WATER 125GAL (STRRET SIDE) |
| | 1 | 8045093 | BULKHEAD 1 1/4" BOTTOM FEED |
| 3 | 2 | 8041119 | WATER TANK LID |
| 4 | 2 | 8041311 | ELBOW, STREET 1 1/4" |
| 5 | 4 | 8041312 | FITTING, HOSE BARB 1 1/4" |
| 6 | 2 | 8041523 | HOSE, VAC CLEAR VINYL 1 1/4" - 24 |
| 7 | 2 | T401102 | ELBOW, 6MJ - 6MP |
| 8 | 1 | 8041477 | HOSE REEL TO BALL VALVE 6 -140 ST-ST |
| 9 | 1 | 8043949 | BALL VALVE TO TANK CLEANOUT 6-215 ST-90 |
| 10 | 4 | U200020 | WASHER, FLAT 1/4" |
| 11 | 4 | U120100 | NUT, LOCK 1/4"-20 |
| 12 | 1 | 8043664 | BALL VALVE TO WATER PUMP 6-36 ST-90 |
| 13 | 1 | 8031126 | UNION, 4FP - 6MJ |
| 14 | 1 | 8030923 | FILTER, WATER HIGH PRESSURE |
| 15 | 1 | 8031125 | REDUCER, 1/4"FP - 3/8"FJ |
| 16 | 1 | 8040670 | BALL VALVE BRACKET |
| 17 | 1 | T402153 | TEE, 6MJ - 6MJ - 6FJ |
| 18 | 2 | 8041310 | TEE, 1 1/4"FP - 1 1/4"FP - 1 1/4"FP |
| 19 | 1 | T403100 | REDUCER, 20MP - 12FP |
| 20 | 1 | T400101 | UNION, 12FJ - 12MP |
| 21 | 1 | T400100 | UNION, 12MJ - 12MP |
| 22 | 1 | T000185 | BALL VALVE, BRASS 3/4"FP |
| 23 | 1 | T404060 | REDUCER, 16MP - 12MP |
| 24 | 1 | 8040186 | STRAINER |
| | 1 | 8040186-1 | END CAP |
| | 1 | 8040186-2 | GASKET |
| | 1 | 8040186-3 | STRAINER PLUG |
| | 1 | 8040186-4 | FKM O-RING |
| | 1 | 8040186-5 | STRAINER MESH SCREEN 80 |
| | 1 | 8040186-6 | Y-BODY |
| | 1 | 8040186-7 | EPDM O-RING |
| 25 | 1 | T400450 | REDUCER, 12MJ - 16MP |
| 26 | 1 | 8041058 | HOSE VAC PUSH 12-36 |
| | 2 | 8030525 | FITTING HOSE 12FJ PUSHLOCK |
| 27 | 1 | 8030351 | BALL VALVE 3/8" |
| | 2 | U010017 | U-BOLT .250 - 20 |
| * | 1 | 8043806 | SWITCH, WATER TANK BOTTOM SHORT |
| * | 1 | 8046803 | HOSE VAC PUSH 8-79 |
| * | 2 | 8030524 | FITTING, PUSH LOCK #8 |
| * | 1 | 8030518 | ELBOW, 45 1/2" MJ BULKHEAD |

* NOT SHOWN

Water Tank Assembly

230 GAL

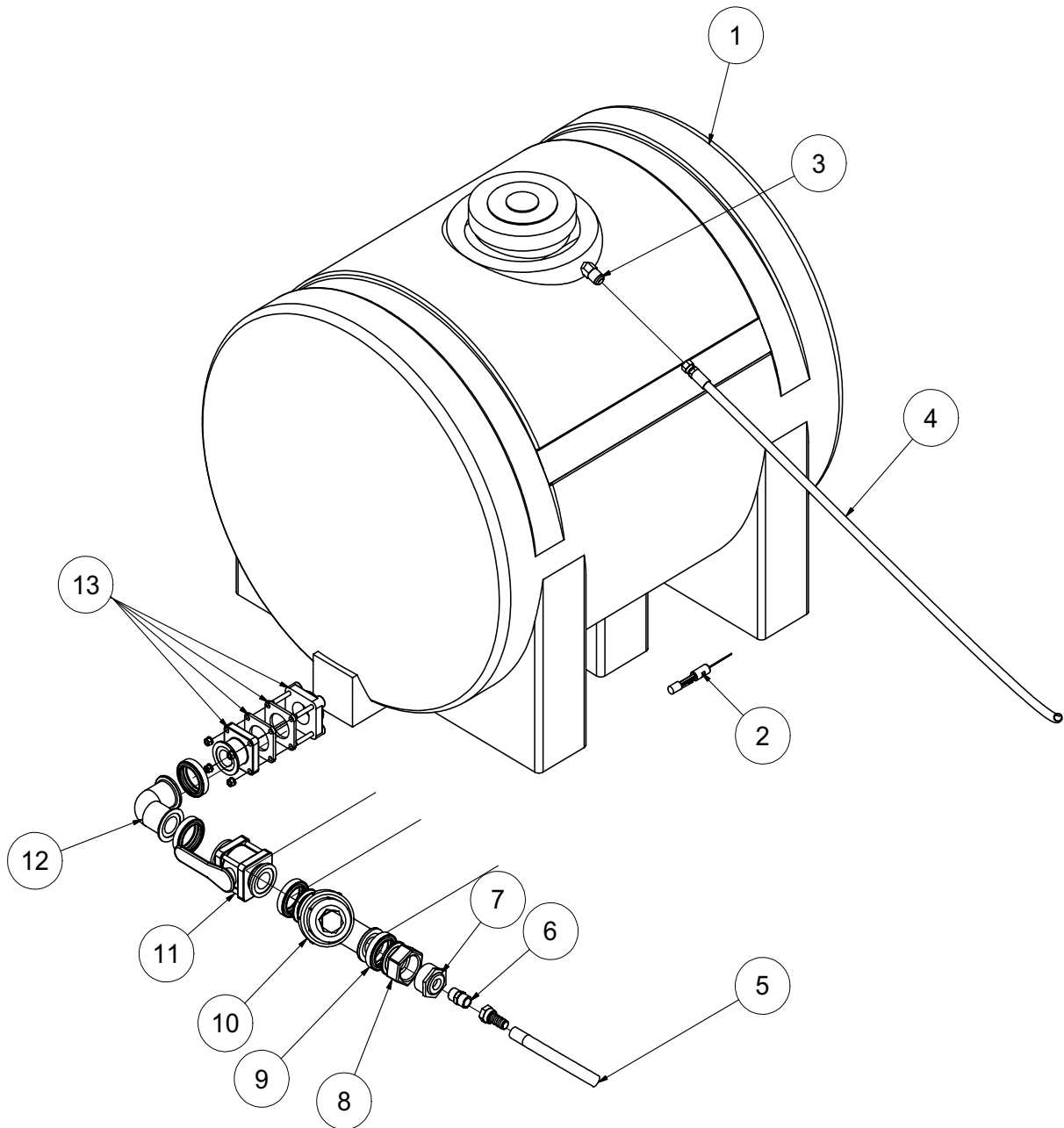

030614-E

VACASSY604

Water Tank Assembly

230 GAL

| ITEM | QTY | NUMBER | DESCRIPTION |
|------|-----|-----------|-----------------------------|
| 1 | 1 | 8030338 | 230 GALLON WATER TANK |
| | 2 | 8040084 | WATER TANK STRAP |
| | 1 | 8030931 | WATER TANK LID |
| 2 | 1 | 8045386 | WATER LEVEL SWITCH, LONG |
| 3 | 1 | 8030518 | BULKHEAD 45 DEG, 8MJ |
| 4 | 1 | 8041465 | HOSE, BYPASS 230 WATER TANK |
| | 2 | 8030524 | PUSH LOCK HOSE FITTING 8FJ |
| 5 | 1 | 8041467 | HOSE, SUCTION |
| | 2 | 8030524 | PUSH LOCK HOSE FITTING 12FJ |
| 6 | 1 | T400100 | UNION, 12MP - 12MJ |
| 7 | 1 | 8031134 | BUSHING, 2" X 3/4"NPT BANJO |
| 8 | 1 | 8030996 | ADAPTER, FEMALE 2" BANJO |
| 9 | 4 | 8031000 | CLAMP, WATER MANIFOLD |
| 10 | 1 | 8031001 | Y-STRAINER, 2" BANJO |
| | 1 | 8031001-1 | SP MANIFOLD BODY |
| | 1 | 8031001-2 | STRAINER CAP |
| | 1 | 8031001-3 | PLUG |
| | 1 | 8031001-4 | O-RING |
| | 1 | 8031001-5 | 2" SP EPDM GASKET |
| | 1 | 8031001-6 | 2" SP VITON GASKET |
| | 1 | 8031001-7 | EPDM O-RING |
| | 1 | 8031001-8 | 2" 80 MESH SCREEN |
| 11 | 1 | 8030998 | BALL VALVE, 1 1/2" ID BANJO |
| 12 | 1 | 8030995 | ELBOW, 2" BANJO |
| 13 | 1 | 80309971 | FLANGE, 2" BANJO |
| | 1 | 80309972 | FLANGE GASKET, 2" BANJO |
| | 1 | 80309972 | FLANGE GASKET, 2" BANJO |
| | 1 | 80309973 | FLANGE BOLTED, 2" BANJO |
| | 4 | U100060 | NUT, HEX 3/8-16 |
| | 4 | U210060 | WASHER, LOCK 3/8 |

030614-E

VACASSY604

Water Tank Assembly

410 TANK

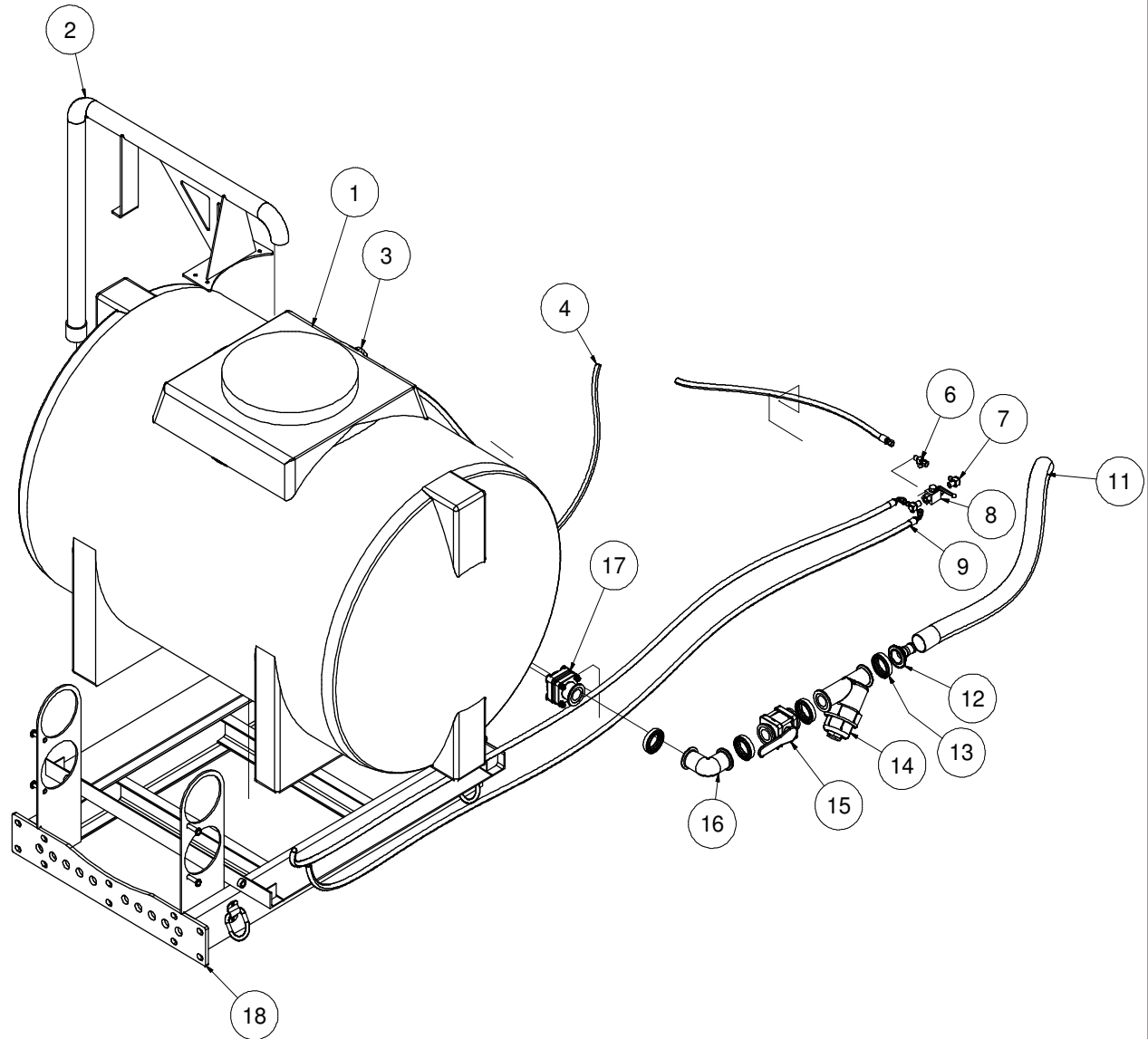

030614-E

VACASSY605

Water Tank Assembly

410 TANK

| ITEM | QTY | NUMBER | DESCRIPTION |
|------|-----|-----------|-------------------------------|
| 1 | 1 | 8031121 | 410 GALLON WATER TANK |
| | 2 | 8041535 | WATER TANK STRAP |
| | 1 | 8031121-1 | 410 GALLON WATER TANK LID |
| 2 | 1 | 8041067 | QUICK FILL |
| | 4 | U000425 | SCREW HC 3/8"-16 X 1" |
| | 8 | U200600 | WASHER FLAT 3/8" |
| | 4 | U210060 | WASHER, LOCK 3/8" |
| | 4 | U100060 | NUT, HEX 3/8"-16 |
| 3 | 1 | 8030518 | 1/2" BULKHEAD 45 DEG. |
| 4 | 1 | 8042184 | HOSE ASSY VAC 8-80 ST-ST |
| 5 | 1 | 8042179 | HOSE ASSY VAC 6-36 ST-ST |
| 6 | 1 | T402153 | TEE #6MJ - #6MJ - #6FJ |
| 7 | 2 | T401102 | ELBOW, #6MJ - 3/8"MP |
| 8 | 1 | 8030351 | 3/8" BALL VALVE |
| 9 | 1 | 8042178 | HOSE ASSY VAC 6-155 ST-90 |
| 10 | 1 | 8042177 | HOSE ASSY VAC 6-254 ST - ST |
| 11 | 1 | 8042189 | HOSE VAC CLEAR VINYL 1 1/4-36 |
| 12 | 1 | 8041999 | FLANGED HOSE BARB 1 1/4" - 2" |
| 13 | 4 | 8031000 | CLAMP, WATER MANIFOLD |
| 14 | 1 | 8031001 | Y-STRAINER, 2" BANJO |
| | 1 | 8031001-1 | 2" SP MANIFOLD BODY |
| | 1 | 8031001-2 | STRAINER CAP |
| | 1 | 8031001-3 | PLUG |
| | 1 | 8031001-4 | O-RING |
| | 1 | 8031001-5 | 2"SP EPDM GASKET |
| | 1 | 8031001-6 | 2" SP VITON GASKET |
| | 1 | 8031001-7 | EPDM O-RING |
| | 1 | 8031001-8 | 2" 80 MESH SCREEN |
| 15 | 1 | 8030998 | BALL VALVE, 1-1/2 ID BANJO |
| 16 | 1 | 8030995 | ELBOW, 2" BANJO |
| 17 | 1 | 80309971 | FLANGE, 2" BANJO |
| | 1 | 80309972 | FLANGE GASKET, 2" BANJO |
| | 1 | 80309972 | FLANGE GASKET, 2" BANJO |
| | 1 | 80309973 | FLANGE BOLTED, 2" BANJO |
| | 4 | U100060 | NUT, HEX 3/8-16 |
| | 4 | U210060 | WASHER, LOCK 3/8 |
| 18 | 1 | 8049116 | SKID, 410 WATER TANK |
| * | 1 | 8045386 | SWITCH, WATER SHUTOFF LONG |

* NOT SHOWN

030614-E

VACASSY605

Water Tank Assembly

205 Gallon Saddle Tanks (Skid)

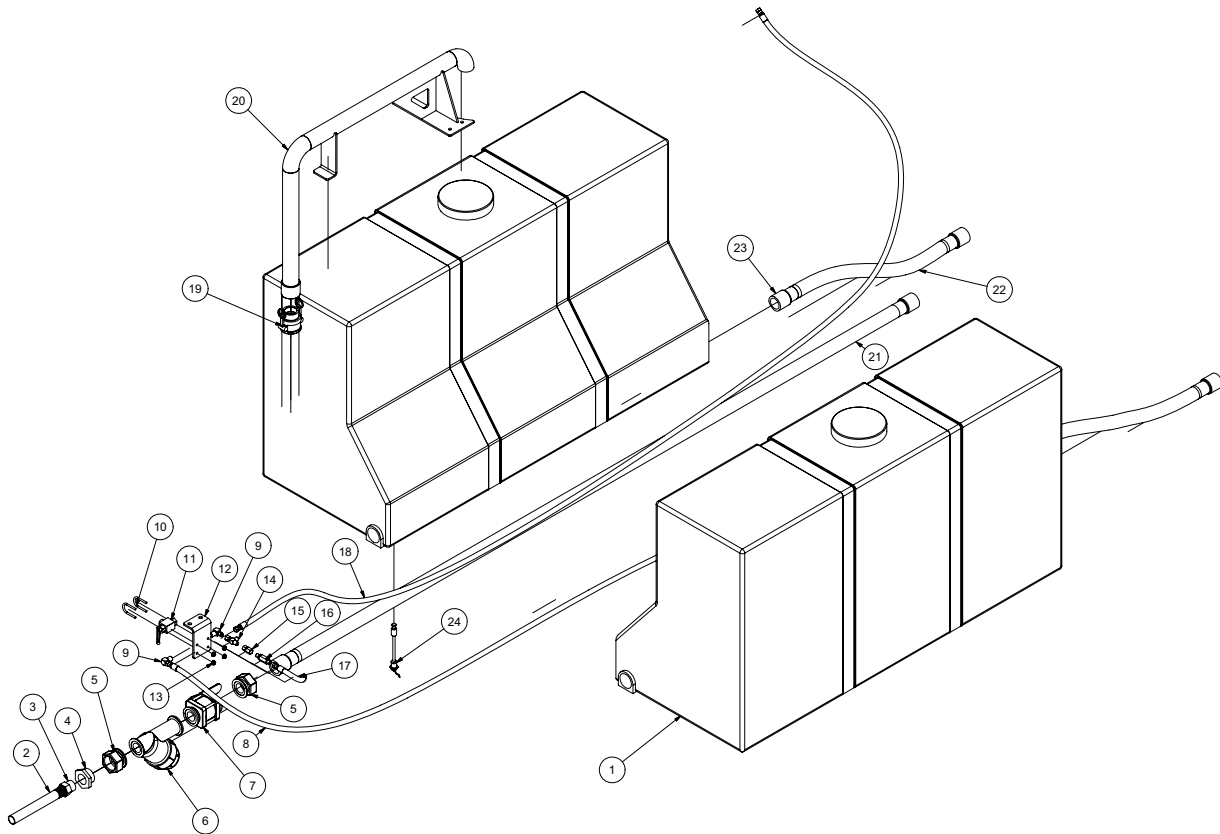

110311-E

VACASSY616

Water Tank Assembly

205 Gallon Saddle Tanks (Skid)

| ITEM | QTY | NUMBER | DESCRIPTION |
|------|-----|-----------|--|
| 1 | 2 | 8043805 | TANK, WATER 205 GAL. POLY. |
| | 2 | 8043805-3 | TANK, WATER LID 205GAL |
| * | 1 | 8030518 | 1/2" BULKHEAD 45 DEG |
| 2 | 1 | 8043076 | HOSE VAC CLEAR VINLY 1 1/4-37" |
| 3 | 1 | 8041312 | FITTING HOSE BARB 20HB-20MP |
| 4 | 1 | 8043843 | REDUCER, 1 1/4"MP - 1/2"FP GALV |
| 5 | 2 | 8030996 | ADAPTER, FEMALE 2" |
| 6 | 1 | 8031001 | Y-STRAINER, 2" |
| | 1 | 8031001-1 | 2" SP MANIFOLD BODY |
| | 1 | 8031001-2 | STRAINER CAP |
| | 1 | 8031001-3 | PLUG |
| | 1 | 8031001-4 | O-RING |
| | 1 | 8031001-5 | 2" SP EPDM GASKET |
| | 1 | 8031001-6 | 2" SP VITON GASKET |
| | 1 | 8031001-7 | EPDM O-RING |
| | 1 | 8031001-8 | 2" 80 MESH SCREEN |
| 7 | 1 | 8030998 | BALL VALVE, BANJO 1 1/2"ID |
| 8 | 1 | 8043949 | BALL VALVE TO TANK CLEAN OUT HOSE #6-215 ST-90 |
| | 2 | T320040 | FITTING, HOSE 6HO-6FJ |
| 9 | 2 | T401102 | ELBOW, 6MJ-6MP |
| 10 | 2 | U010017 | 1 1/2" CLAMP HOOK 1/4-20 THD |
| 11 | 1 | 8030351 | STEEL BALL VALVE, 3/8" NPT |
| 12 | 1 | 8040670 | BALL VALVE BRACKET |
| 13 | 8 | U120142 | NUT, LOCK FLANGED .250-20 G2 |
| | 8 | U200020 | WASHER, FLAT 1/4" |
| 14 | 1 | T402153 | TEE, 6MJ-6MJ-6FJ |
| 15 | 1 | 8031125 | UNION, 4FP-6FJ |
| 16 | 1 | 8030923 | FILTER, WATER HIGH PRESSURE |
| 17 | 1 | 8043664 | BALL VALVE TO WATER PUMP HOSE #6-36 ST-90 |
| 18 | 1 | 8041477 | HOSE REEL TO BALL VALVE HOSE #6-140 ST-ST |
| | 2 | T320040 | FITTING, HOSE 6HO-6FJ |
| 19 | 1 | 8031219 | COUPLING, 2" ALUM MP X FCAMLOCK |
| 20 | 1 | 8046528 | QUICK FILL 205 GAL |
| 21 | 1 | 8045635 | HOSE VAC CLEAR VINLY 2"-122 |
| | 2 | 8043397 | CLAMP VAC CLEAR HOSE 2" |
| 22 | 2 | 8045636 | HOSE VAC CLEAR VINLY 2"-36 |
| | 2 | 8043397 | CLAMP VAC CLEAR HOSE 2" |
| 23 | 6 | T410115 | HOSE BARB 2" |
| 24 | 1 | 8045386 | SWITCH, WATER TANK BOTTOM LONG |

* NOT SHOWN

Hose Reel Assembly

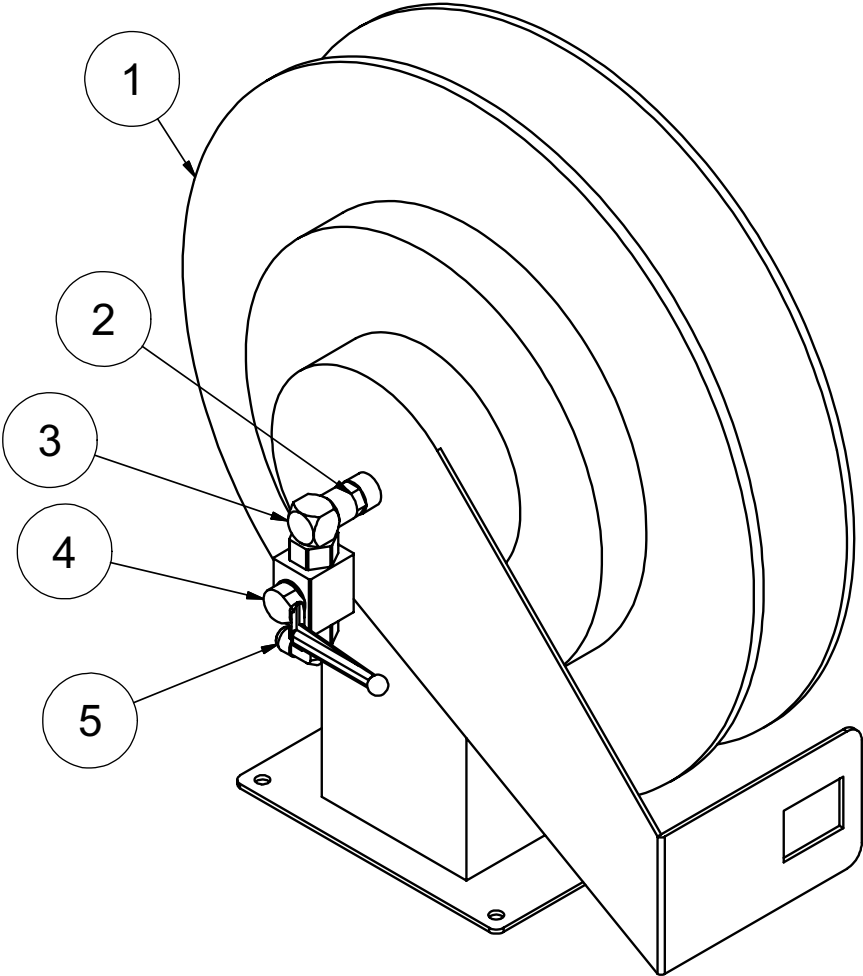

081010-E

VACASSY763

Hose Reel Assembly

| ITEM | QTY | NUMBER | DESCRIPTION |
|------|-----|---------|--|
| 1 | 1 | 8031240 | REEL with HOSE SPRINGDRIVEN 3/8" X 50' |
| 2 | 1 | 8031269 | UNION, 1/2"MP - 3/8"MP |
| 3 | 1 | T401065 | ELBOW, 3/8"MP - 3/8"FP |
| 4 | 1 | 8030351 | STEEL BALL VALVE - 3/8"NPT |
| 5 | 1 | 8030498 | ELBOW, 3/8"MP - 3/8"MJ 90 |

081010-E

VACASSY763

Hose Reel

Components

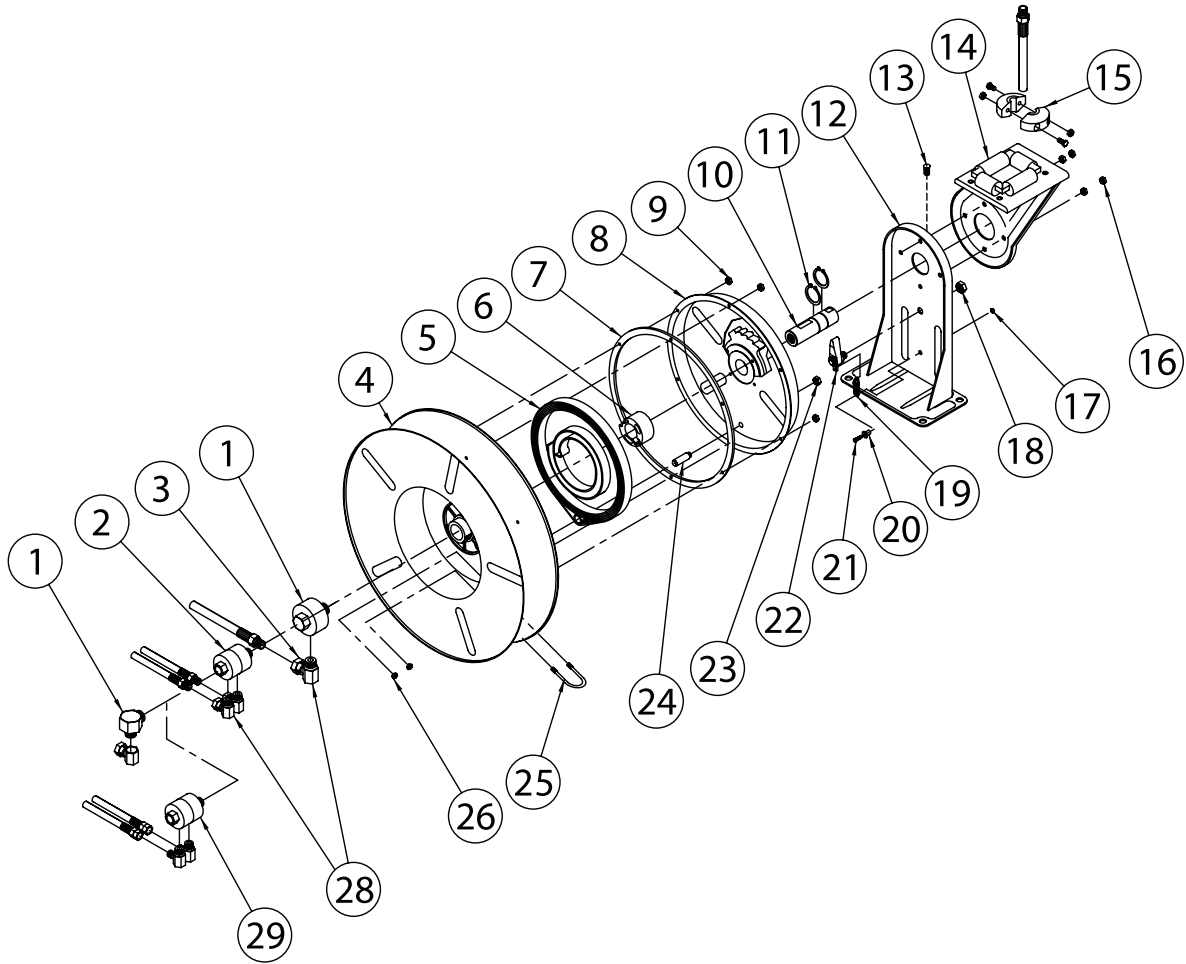

081010-E

VACASSY764

Hose Reel

Components

| ITEM | QTY | NUMBER | DESCRIPTION |
|------|-----|------------|--|
| | | 8031240 | REEL with HOSE SPRINGDRIVEN 3/8" X 50' |
| 1 | 1 | 8031240-1 | SWIVELASSEMBLY |
| 2 | 1 | 8031240-2 | SWIVEL & ELLASSEMBLY |
| 3 | 1 | 8031240-3 | 90 DEG ELL |
| 4 | 1 | 8031240-4 | SHEAVEASSEMBLY |
| 5 | 1 | 8031240-5 | DRIVE SPRINGASSEMBLY |
| 6 | 1 | 8031240-6 | SPRINGARBORASSEMBLY |
| 7 | 1 | 8031240-7 | GASKET |
| 8 | 1 | 8031240-8 | SPRING CASEASSEMBLY |
| 9 | 6 | 8031240-9 | 10-32 HEX LOCKNUT |
| 10 | 1 | 8031240-10 | MAIN SHAFT |
| 11 | 2 | 8031240-11 | 1 1/4" SNAP RING |
| 12 | 1 | 8031240-12 | BASE ASSEMBLY |
| 13 | 1 | 8031240-13 | 1/2"-13 SET SCREW |
| 14 | 1 | 8031240-14 | GUIDE ARM W/ ROLLERS |
| 15 | 1 | 8031240-15 | HOSE BUMPERASSEMBLY |
| 16 | 4 | 8031240-16 | 5/16"-18 LOCKNUT |
| 17 | 1 | 8031240-17 | 10-32 X 3/8" NYLOCK NUT |
| 18 | 1 | 8031240-18 | 1/2"-20 X 5/8" HEX NUT |
| 19 | 1 | 8031240-19 | LATCH SPRING |
| 20 | 1 | 8031240-20 | BUSHING |
| 21 | 1 | 8031240-21 | 10-32 X 7/8" SCREW |
| 22 | 1 | 8031240-22 | LATCH PAWLASSEMBLY |
| 23 | 1 | 8031240-23 | 3/8"-24 JAM NUT |
| 24 | 1 | 8031240-24 | SPRING CASE STUD |
| 25 | 1 | 8031240-25 | U-BOLT |
| 26 | 4 | 8031240-26 | 1/4"-20 X 3/8" LOCKNUT |
| 28 | 1 | 8031240-28 | SWIVEL UNION |

081010-E

VACASSY764

Antifreeze Assembly

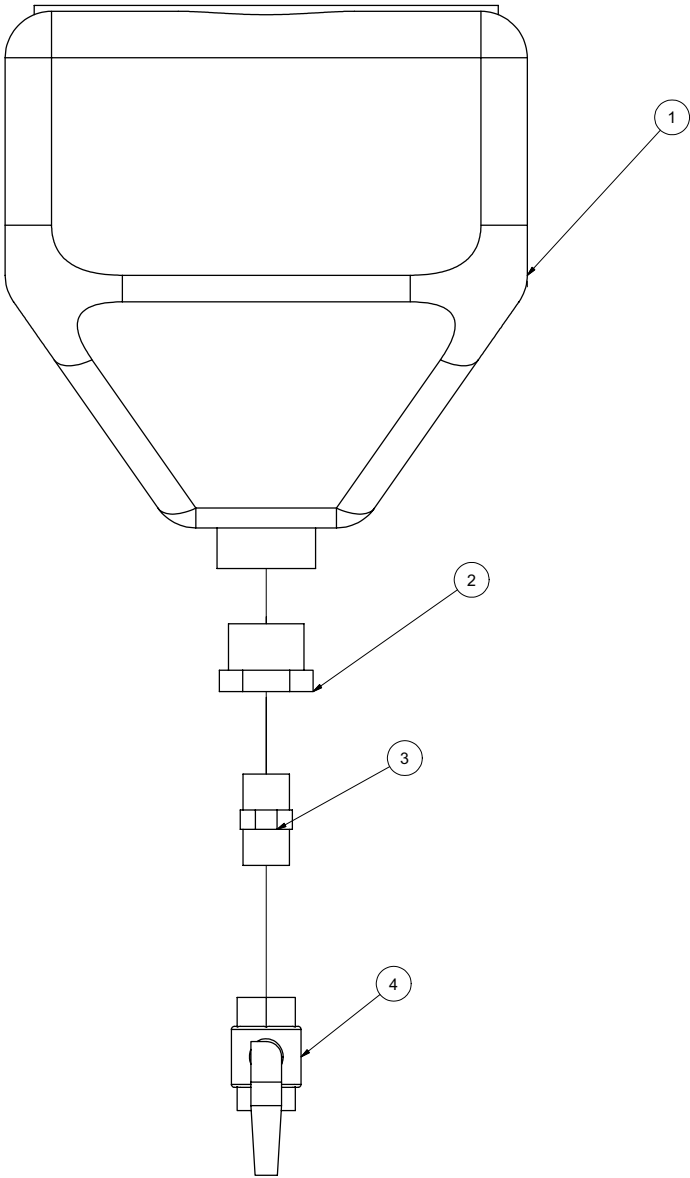

060309

VACASSY943

Antifreeze Assembly

| ITEM | QTY | PART NO. | DESCRIPTION |
|------|-----|----------|---------------------------|
| 1 | 1 | 8030394 | ANTI-FREEZE TANK 4 GAL. |
| | 4 | U000180 | SCREW, HC .312 -18 X .750 |
| | 4 | U200040 | WASHER, FLAT 5/16" |
| | 4 | U210040 | WASHER, LOCK 5/16" |
| 2 | 1 | T400585 | REDUCER, 20MP-12FP |
| 3 | 1 | T400800 | UNION, 12MP-12MP |
| 4 | 1 | T000185 | BALL VALVE, BRASS 3/4" FP |

060309

VACASSY943

Skid Assembly

V800HD SINGLE

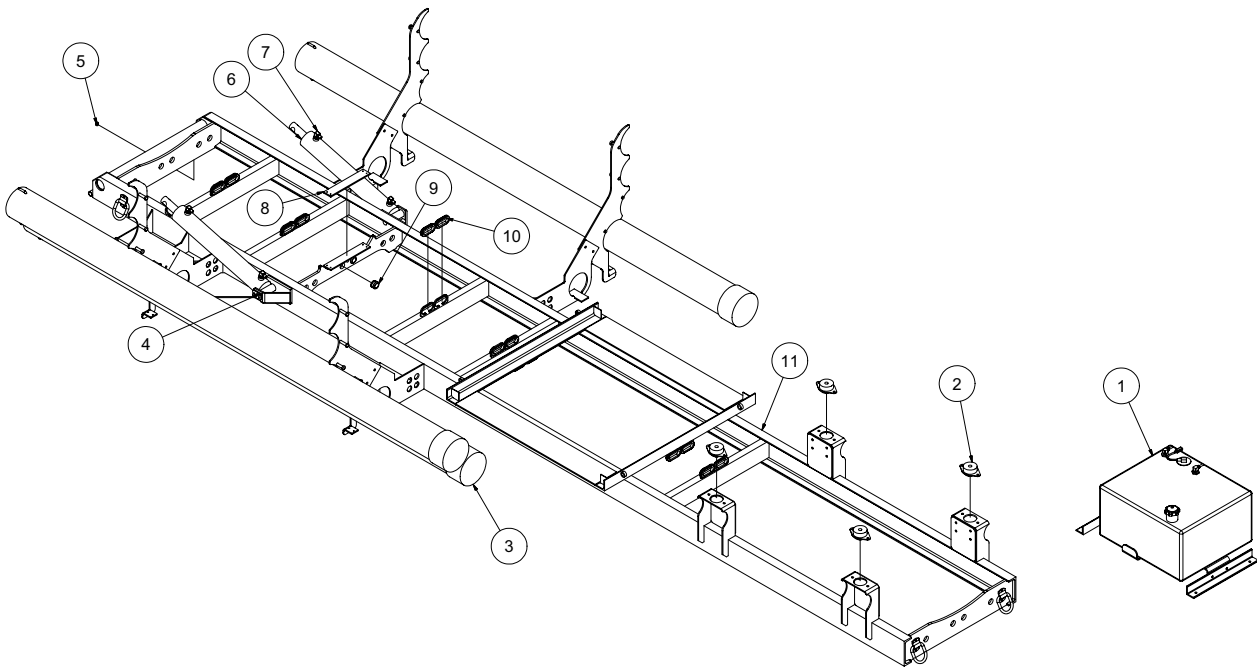

121510-E

VACASSY921

Skid Assembly

V800HD SINGLE

| ITEM | QTY | PART # | DESCRIPTION | |
|------|-----|-----------|--|------------------------|
| 1 | 1 | 8042380 | FUEL TANK 22GAL | |
| | 1 | 8043359 | STRAP W/ EYEBOLT | |
| | 1 | 8042380-1 | FUEL TANK CAP | |
| | 1 | 8041725 | FUEL SENDING UNIT | |
| | 1 | 8041725-1 | SENDING UNIT GASKET | |
| | 1 | 8045686 | FUEL LINE SUPPLY 30" | |
| | 2 | 8043665 | FUEL TANK MTG FOOT | |
| | 1 | 8045507 | PLATE FUEL TANK HOLDER | |
| | 2 | 4 | 8030904 | ISOLATOR 840LB |
| | | 4 | U000560 | SCREW, HC 3/8"-16 X 3" |
| | | 4 | 8030851 | WASHER, SNUBBLING |
| 4 | | U120110 | NUT, LOCK 3/8" | |
| 8 | | U000420 | SCREW, HC 3/8"-16 X 1" | |
| 24 | | U200060 | WASHER, FLAT 3/8"-16 | |
| 8 | | U210060 | WASHER, LOCK 3/8" | |
| 8 | | U100060 | NUT, HEX 3/8"-16 | |
| 3 | | 3 | 8041102 | HOSE STORAGE 6" X 10' |
| | | 3 | 8030925 | END CAP 6" |
| | 3 | 8041485 | LANYARD CABLE | |
| | 3 | 8041101 | HOSE STORAGE RETAINING ROD | |
| | 4 | 2 | 8043844 | PIN CYLINDER V1200 |
| 5 | 2 | T500060 | FITTING, GREASE .125 90DEG | |
| 6 | 2 | 8030359 | CYLINDER, HYD 3.0" X 20" | |
| 7 | 4 | T401270 | ELBOW, 90 1/2"MB - 3/8"MJ | |
| 8 | 1 | 8045787 | STRIP PLASTIC TANK FOOT LE | |
| 9 | 2 | 8041686 | GROMMET 1"ID - 1 1/4"DOG - 1/4"WO | |
| 10 | 14 | 8042812 | GROMMET 2"ID - 3"OD - 1/4"WOG TRAILER SLOT MODEL | |
| 11 | 1 | 8046834 | SKID WELD'T VSK800HD 410 SGL | |

DOOR HOSES

| | | | |
|---|---|---------|--|
| * | 2 | 8042928 | HYD HOSE TO DOOR CYLINDER BASE END 4-38" ST-ST |
| * | 2 | 8043304 | HYD HOSE TO DOOR CYLINDER ROD END 4-47" ST-ST |
| * | 1 | 8046932 | HYD HOSE, DOOR CYLINDER SUPPLY 4-206" ST-90 |
| * | 1 | 8046932 | HYD HOSE, DOOR CYLINDER RETURN 4-206" ST-90 |
| * | 2 | T402035 | TEE, 1/4"MJ - 1/4"MJ - 1/4"MJ |

TANK HOSES

| | | | |
|---|---|---------|--|
| * | 2 | 8042948 | HYD HOSE TO TANK CYLINDER BASE END 6-36" ST-ST |
| * | 2 | 8046933 | HYD HOSE TO TANK CYLINDER ROD END 6-57" ST-ST |
| * | 1 | 8046934 | HYD HOSE, TANK CYLINDER SUPPLY 6-132" ST-90 |
| * | 1 | 8046934 | HYD HOSE, TANK CYLINDER RETURN 6-132" ST-90 |
| * | 2 | T402154 | TEE, 3/8"MJ - 3/8"MJ - 3/8"MJ |

Skid Assembly

V500/800HD 205 SADDLE TANKS

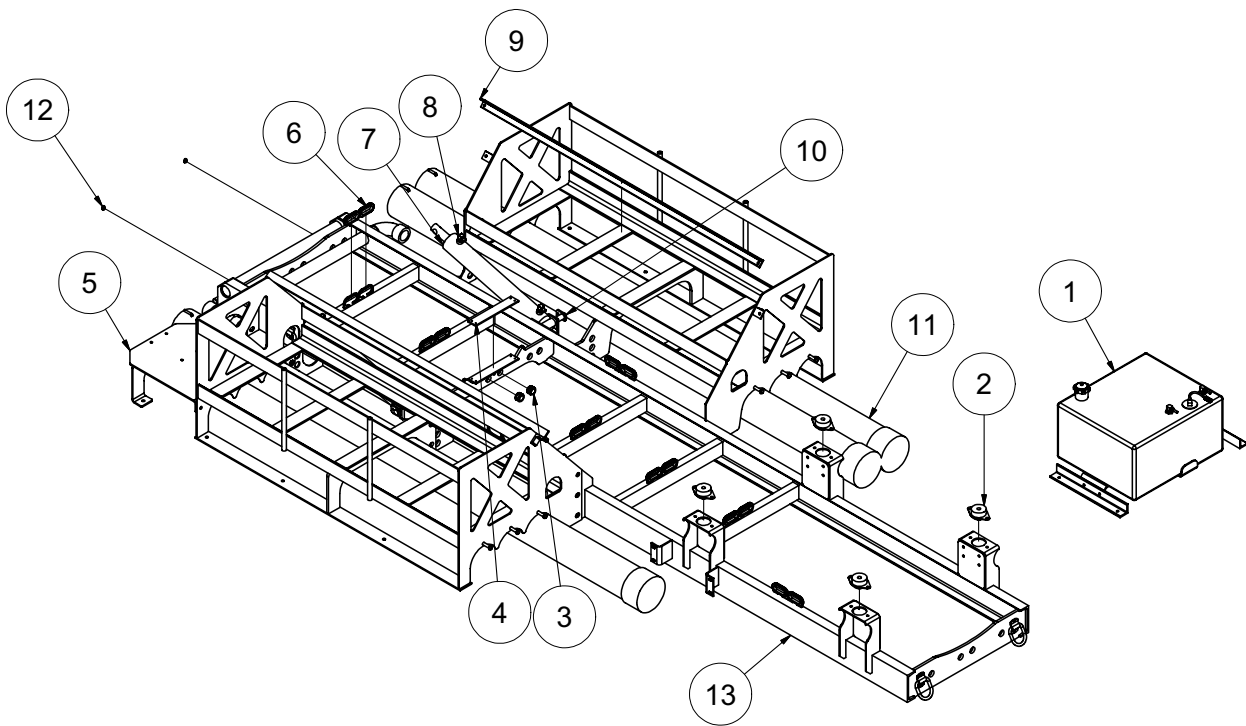

010411-E

VACASSY922

Skid Assembly

V500/800HD 205 SADDLE TANKS

| ITEM | QTY | PART # | DESCRIPTION |
|------|-----|-----------|--|
| 1 | 1 | 8042380 | FUEL TANK 22GAL |
| | 1 | 8043359 | STRAP W/ EYEBOLT |
| | 1 | 8042380-1 | FUEL TANK CAP |
| | 1 | 8041725 | FUEL SENDING UNIT |
| | 1 | 8041725-1 | SENDING UNIT GASKET |
| | 1 | 8045686 | FUEL LINE SUPPLY 30" |
| | 2 | 8043665 | FUEL TANK MTG FOOT |
| | 1 | 8045507 | PLATE FUEL TANK HOLDER |
| | 2 | 4 | 8030904 |
| 4 | | U000560 | SCREW, HC 3/8"-16 X 3" |
| 4 | | 8030851 | WASHER, SNUBBLING |
| 4 | | U120110 | NUT, LOCK 3/8" |
| 8 | | U000420 | SCREW, HC 3/8"-16 X 1" |
| 24 | | U200060 | WASHER, FLAT 3/8"-16 |
| 8 | | U210060 | WASHER, LOCK 3/8" |
| 8 | | U100060 | NUT, HEX 3/8"-16 |
| 3 | 2 | 8041686 | GROMMET 1"ID - 1 1/4"DOG - 1/4"WO |
| 4 | 1 | 8045787 | STRIP PLASTIC TANK FOOT LE |
| 5 | 1 | 8046823 | BRACKET, HOSE REEL SKID |
| 6 | 14 | 8042812 | GROMMET 2"ID - 3"OD - 1/4"WOG TRAILER SLOT MODEL |
| 7 | 2 | 8030359 | CYLINDER, HYD 3.0" X 20" |
| 8 | 4 | T401270 | ELBOW, 90 1/2"MB - 3/8"MJ |
| 9 | 2 | 8044390 | WATER TANK ANGLE HOLDER |
| 10 | 2 | 8043844 | PIN CYLINDER |
| 11 | 3 | 8041102 | HOSE STORAGE 6" X 10' |
| | 3 | 8030925 | END CAP 6" |
| | 3 | 8041485 | LANYARD CABLE |
| | 3 | 8041101 | HOSE STORAGE RETAINING ROD |
| 12 | 2 | T500060 | FITTING, GREASE .125 90DEG |
| 13 | 1 | 8046784 | SKID WELD'T VSK500/800HD 205ST |

DOOR HOSES

| | | | |
|---|---|---------|--|
| * | 2 | 8045870 | HYD HOSE TO DOOR CYLINDER BASE END 4-41" ST-ST |
| * | 2 | 8042927 | HYD HOSE TO DOOR CYLINDER ROD END 4-50" ST-ST |
| * | 1 | 8046936 | HYD HOSE, DOOR CYLINDER SUPPLY 4-158" ST-90 |
| * | 1 | 8046936 | HYD HOSE, DOOR CYLINDER RETURN 4-158" ST-90 |
| * | 2 | T402035 | TEE, 1/4"MJ - 1/4"MJ - 1/4"MJ |

TANK HOSES

| | | | |
|---|---|---------|--|
| * | 2 | 8042948 | HYD HOSE TO TANK CYLINDER BASE END 6-36" ST-ST |
| * | 2 | 8046933 | HYD HOSE TO TANK CYLINDER ROD END 6-57" ST-ST |
| * | 1 | 8046935 | HYD HOSE, TANK CYLINDER SUPPLY 6-94" ST-90 |
| * | 1 | 8046935 | HYD HOSE, TANK CYLINDER RETURN 6-94" ST-90 |
| * | 2 | T402154 | TEE, 3/8"MJ - 3/8"MJ - 3/8"MJ |

HOSES

4"

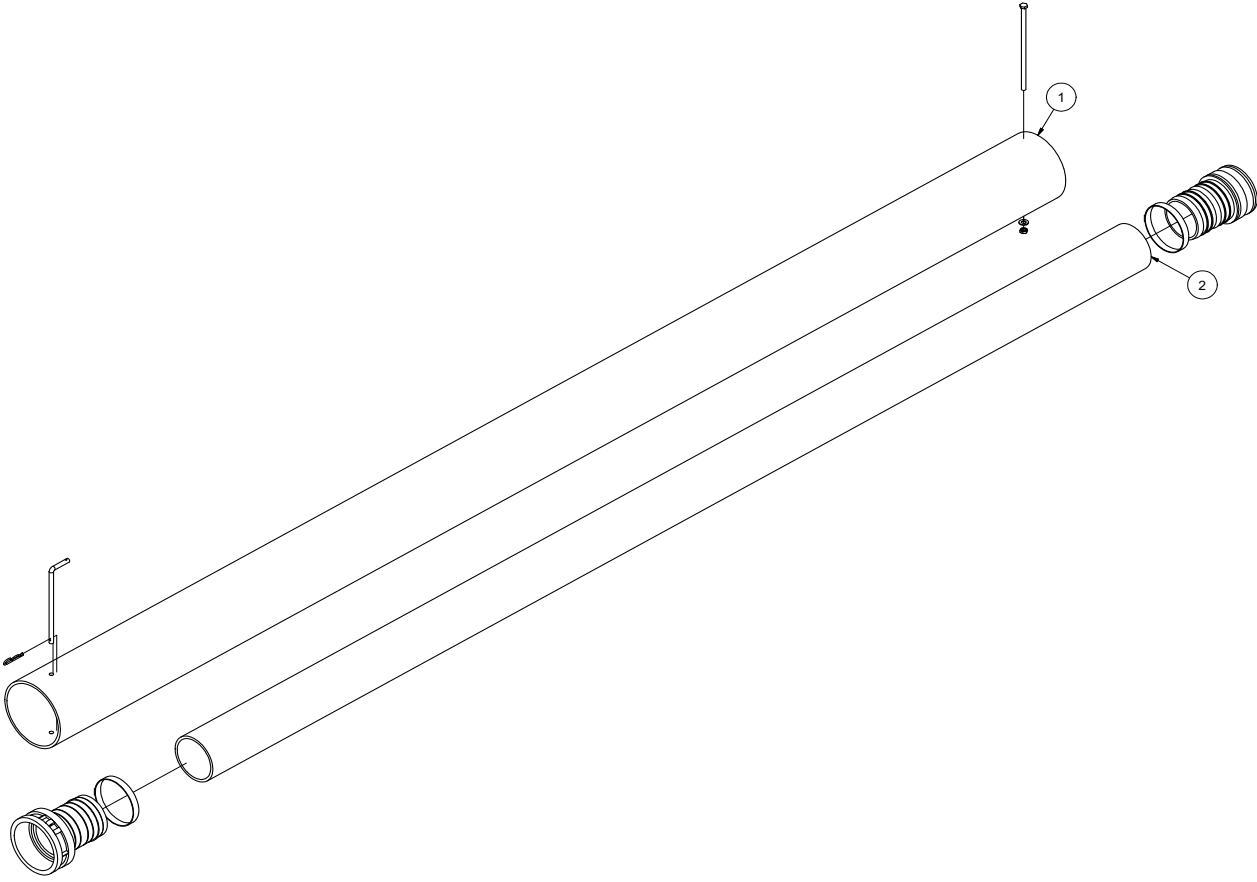

HOSES

4''

| ITEM | QTY | PART NO. | DESCRIPTION | |
|------|-----|----------|------------------------------|------------------------------|
| 1 | 1 | 8041102 | 6" PVC STORAGE TUBE 10' LG | |
| | 1 | U000626 | SCREW, HC .375-16 X 7.50" | |
| | 1 | 8041485 | LANYARD CABLE | |
| | 1 | 8043198 | HOSE STORAGE CLAMP | |
| | 2 | U200060 | WASHER, FLAT 3/8" | |
| | 2 | U100060 | NUT, HEX 3/8" | |
| | 1 | 8041101 | HOSE STORAGE RETAINING ROD | |
| | 1 | R700170 | R-CLIP, 1/2 - 5/8 SHANK | |
| | 2 | 1 | 8042310 | HOSE VAC KANAFLEX 4-112 |
| | | 1 | 8046444 | CAMLOCK, 4" AL FCAM X M BARB |
| 1 | | 8046443 | CAMLOCK, 4" AL MCAM X M BARB | |
| 2 | | 8030912 | CLAMP, 4.5" PUNCHLOK P18-S | |

Tool Rack Assembly

HD

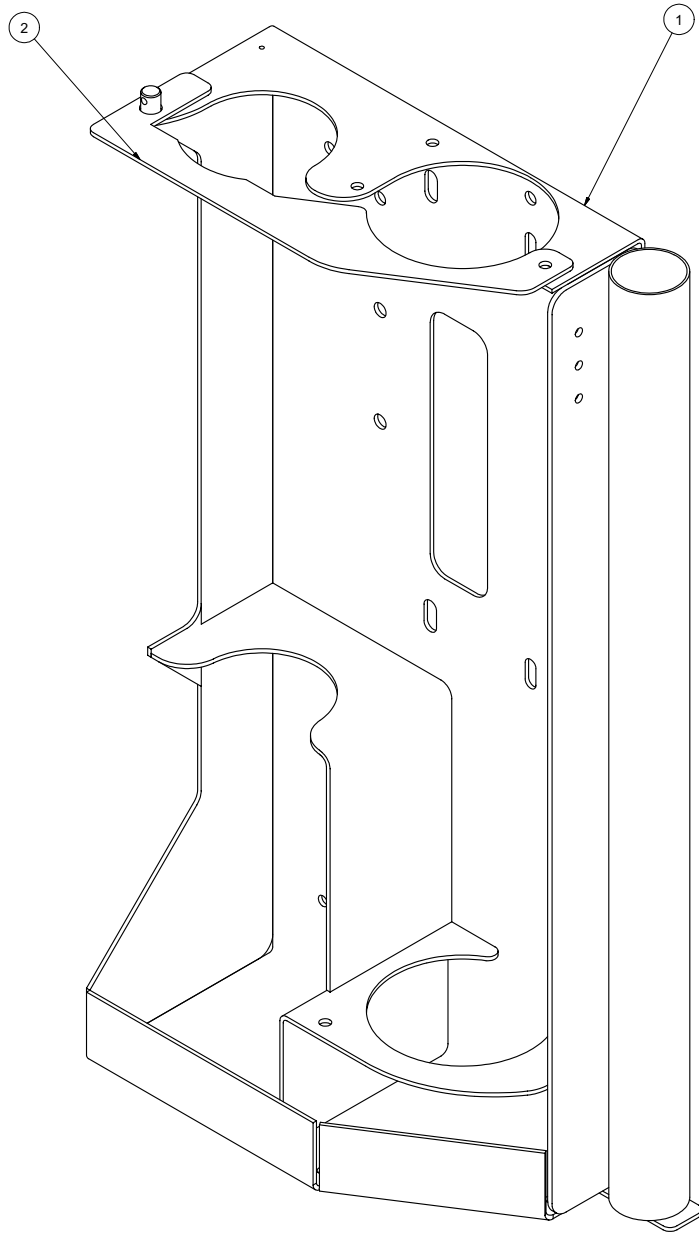

I-BEAM TRAILER

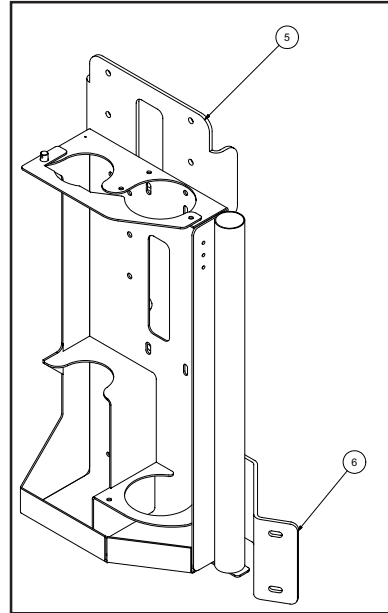

SKID UNIT

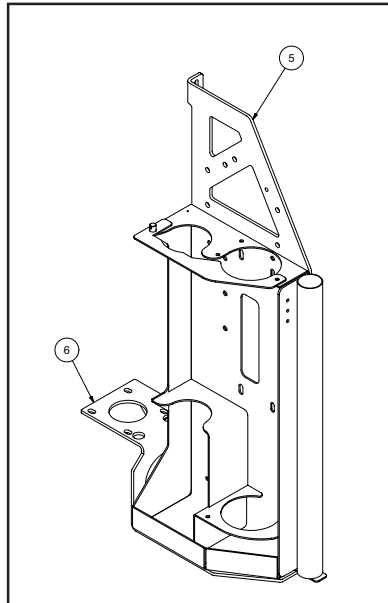

100112-E

VACASSY758

Tool Rack Assembly

HD

| ITEM | QTY | PART NO. | DESCRIPTION |
|------|-----|----------|--|
| 1 | 1 | 8040985 | TOOL RACK WELDMENT, HD |
| 2 | 1 | 8040989 | TOOL RACK CLOSURE, HD |
| | 1 | R700175 | R CLIP 7/8" |
| | 1 | 8041259 | STRAP, 10" |
| | 1 | 8041485 | LANYARD CABLE |
| | 1 | 8041244 | CLEVIS PIN 1/2" DIA. 3/4" |
| 3 | 1 | 8044818 | ANTIFREEZE BRACKET (I-BEAM TRAILER) |
| | 4 | U000020 | SCREW, HC 5/16 - 18 X 1.00" |
| | 4 | U000180 | SCREW, HC 5/16 - 18 X .750" |
| | 16 | U200040 | WASHER, FLAT 5/16" |
| | 8 | U210041 | NUT, LOCK, NY 5/16" |
| 4 | 1 | 8044817 | TOOL RACK BRACKET (I-BEAM TRAILER) |
| | 3 | U000420 | SCREW, HC .375 - 16 X 1.00 |
| | 3 | U120110 | NUT, LOCK .375 - 16 |
| | 6 | U200600 | WASHER, FLAT .375 |
| 5 | 1 | 8041780 | ENCLOSURE STIFFENER BRACE (SKID UNITS) |
| | 4 | U000040 | SCREW, HC 1/4"-20 X .750" |
| | 8 | U200020 | WASHER, FLAT .250" |
| | 4 | U120100 | NUT, LOCK .250" |
| 6 | 1 | 8043601 | TOOL RACK BRACKET - VK (SKID UNITS) |
| | 4 | U000420 | SCREW, HC .375"-16 X 1.00" |
| | 8 | U200060 | WASHER, FLAT .375" |
| | 4 | U120110 | NUT, LOCK .375-16 |
| | 2 | U000040 | SCREW, HC 1/4"-20 X .750" |
| | 4 | U200020 | WASHER, FLAT .250" |
| | 2 | U120100 | NUT, LOCK .250" |
| * | 1 | 8045610 | TOOL RACK 3" TOP INSERT |
| * | 1 | 8045609 | TOOL RACK 3" BOTTOM INSERT |

* NOT SHOWN

Tool Rack Assembly

Horizontal

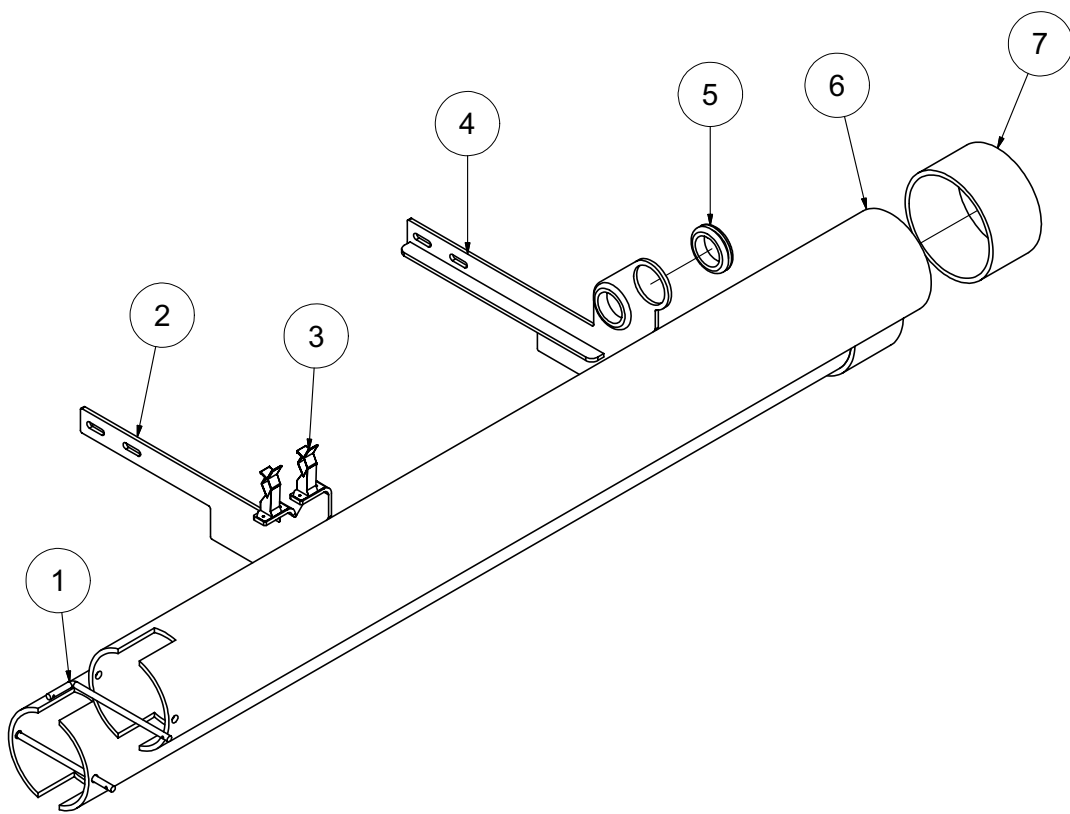

082410-E

VACASSY767

Tool Rack Assembly

Horizontal

| ITEM | QTY | PART NO. | DESCRIPTION |
|------|-----|----------|----------------------------|
| 1 | 2 | 8041101 | HOSE STORAGE RETAINING ROD |
| | 2 | 8041485 | LANYARD CABLE |
| | 2 | R700160 | R-CLIP |
| 2 | 1 | 8046722 | HOSE STORAGE BRACKET |
| 3 | 2 | 8040899 | CLIP, TOOL HOLDER |
| 4 | 1 | 8046724 | HOSE STORAGE BRACKET |
| 5 | 2 | 8042812 | GROMMET 2"ID 1/4"WOG |
| 6 | 2 | 8042222 | BOOM EXT. HOSE STORAGE |
| 7 | 2 | 8030925 | END CAP 6" |

Tools (Option)

HD Reduction Tool

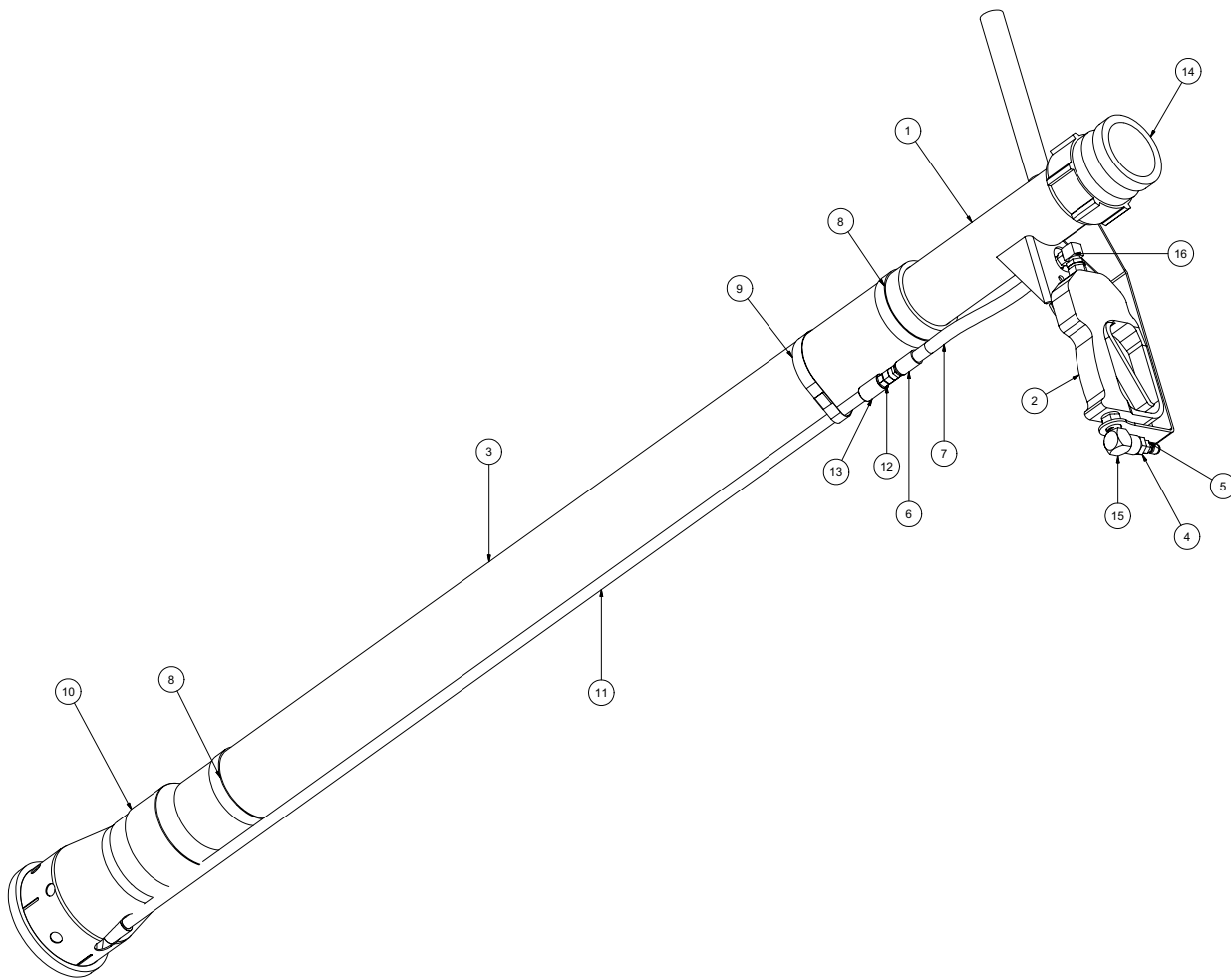

Tools (Option)

HD Reduction Tool

| ITEM | QTY | PART NO. | DESCRIPTION |
|------|-----|----------|----------------------------------|
| - | - | 8043115 | TOOL VAC REDUCTION HD COMPLETE |
| 1 | 1 | 8042862 | TOOL VAC HEAD ASSY 3" |
| 2 | 1 | 8048567 | STRAIGHT SPRAY GUN |
| 3 | 1 | 8042811 | TOOL VAC REDUCTION PVC 3" X 48" |
| 4 | 1 | T400023 | UNION 6MP 4FP |
| 5 | 1 | 8030486 | WATER QD 1/4 MNPT SS |
| 6 | 2 | T320030 | FITTING, HOSE 4HO 4FJ |
| 7 | 1 | 8031278 | HOSE ASSEMBLY REDUCTION TOOL |
| 8 | 2 | 8030244 | VAC CLAMP BAND 3 1/2" PUNCHLOCK |
| 9 | 1 | 8030244 | VAC CLAMP BAND 3 1/2" PUNCHLOCK |
| 10 | 1 | 8041099 | TOOL VAC REDUCTION HD LOWER ASSY |
| 11 | 1 | 8030247 | VAC WATER SUPPLY TUBE |
| 12 | 1 | T400020 | UNION 1/4" MP-1/4" MJ STRAIGHT |
| 13 | 2 | T422010 | COUPLING,PIPE 1/4"FP |
| 14 | 1 | 8030391 | BANJO 3" MALE 3" FNPT |
| 15 | 1 | T401065 | ELBOW, 3/8 MP - 3/8 FP |
| 16 | 1 | T401100 | ELBOW 4MP 4MJ 90 |
| * | 2 | 8030370 | REDUCTION TOOL NOZZLE |
| * | 2 | 8031268 | REDUCTION TOOL NOZZLE 45 DEG |

* NOT SHOWN

Tools

4" Suction Tool

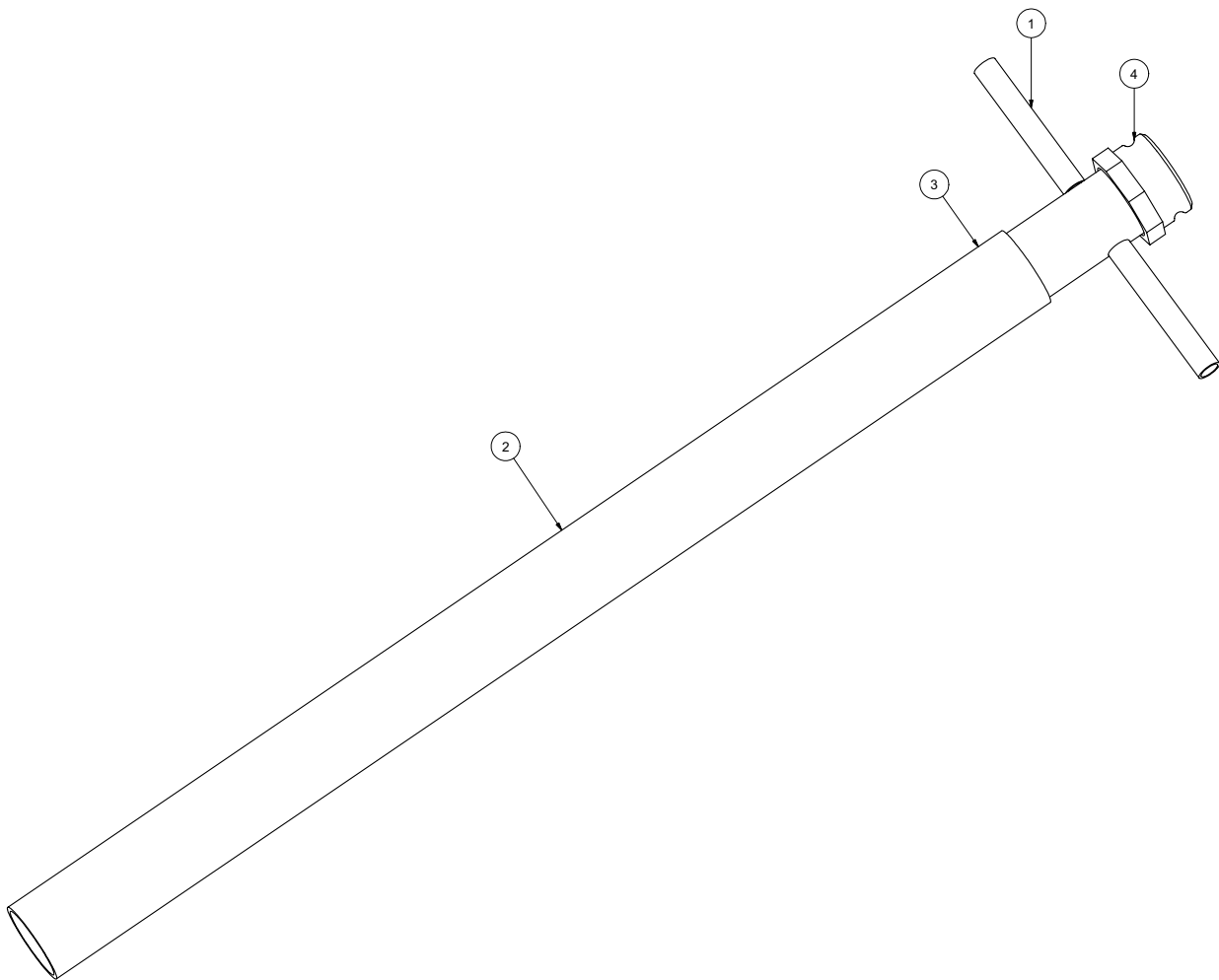

072308

VACASSY710

Tools

4" Suction Tool

| ITEM | QTY | NUMBER | DESCRIPTION |
|-------------|------------|---------------|------------------------------|
| | 1 | 8040983 | TOOL VAC SUCTION 4" COMPLETE |
| 1 | 1 | 8040981 | TOOL VAC HANDLE ASSEMBLY 4" |
| 2 | 1 | 8040982 | PVC VACUUM TUBE 4" |
| 3 | 1 | 8030912 | CLAMP, 4.5" PUNCHLOK |
| 4 | 1 | 8030844 | COUPLING, 4" BANJO |

072308

VACASSY710

Tools

Wash Wand

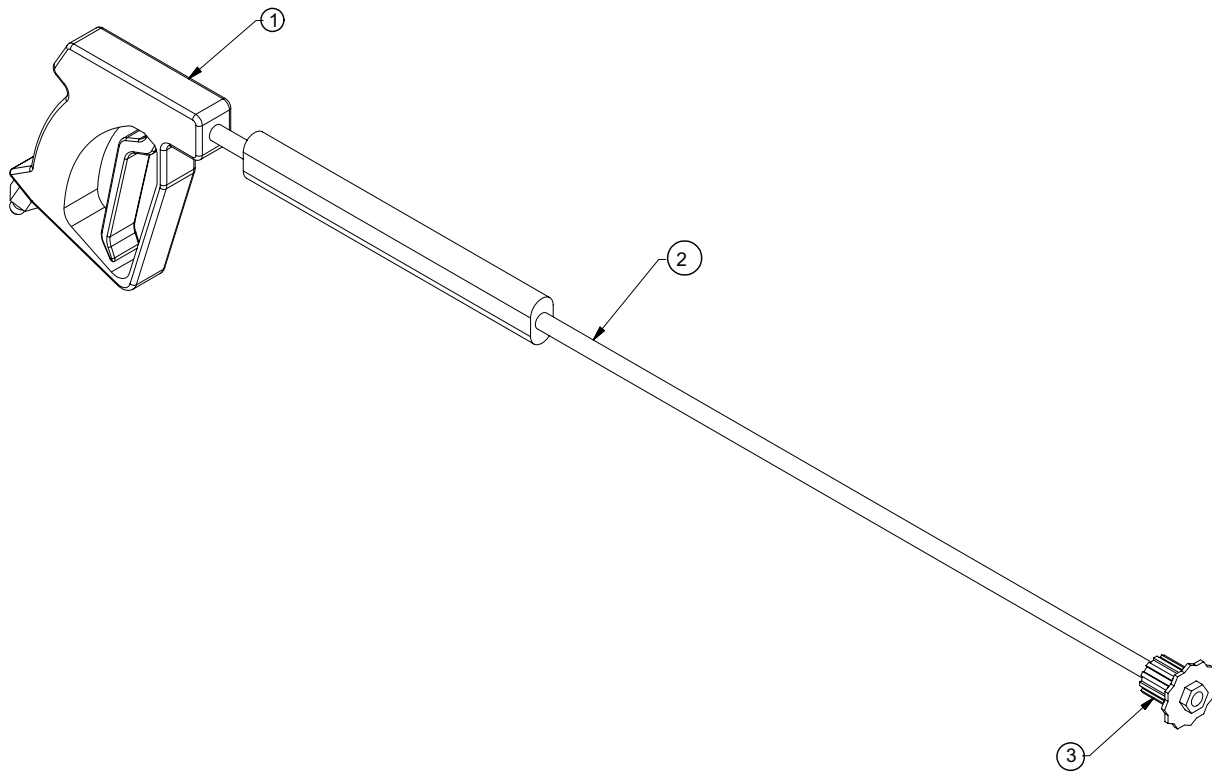

042610-E

VACASSY711

Tools

Wash Wand

| Item | Qty | Number | Description |
|-------------|------------|---------------|------------------------------|
| 1 | 1 | 8030348 | TOOL VAC SPRAY WAND COMPLETE |
| 2 | 1 | 8030928 | TRIGGERASSEMBLY |
| 3 | 1 | 8030847 | WAND |
| | | 8031308 | NOZZLE,#6 40 DEGREE FOR WAND |

042610-E

VACASSY711

Valve Box Cleanout Tool

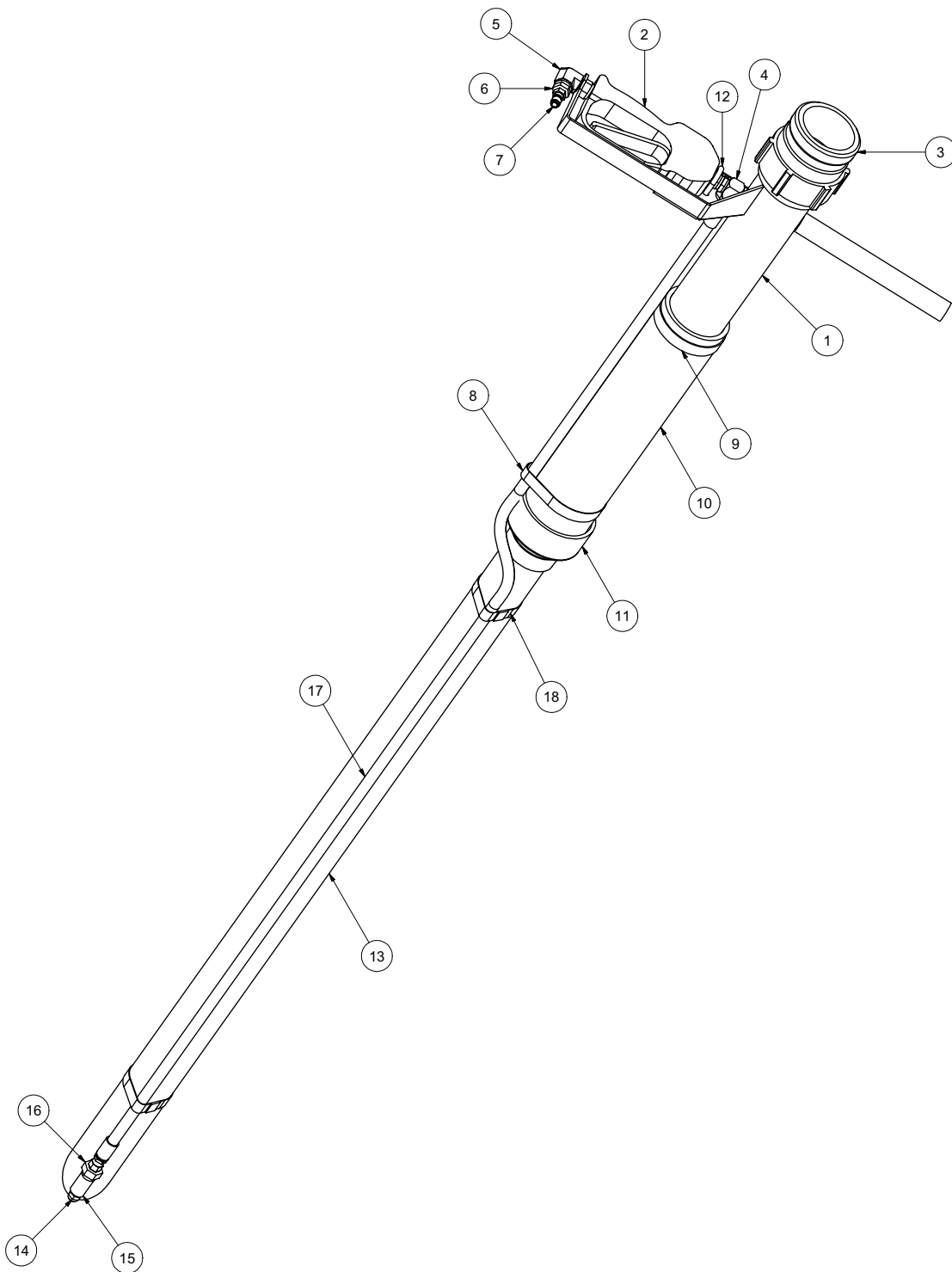

101812-E

VACASSY714

Valve Box Cleanout Tool

| ITEM | QTY | PART NO. | DESCRIPTION |
|------|-----|----------|---------------------------------------|
| | 1 | 8043384 | VAC TOOL VALVEBOX CLEANOUT COMPLETE |
| 1 | 1 | 8042862 | REDUCTION TOOL HEAD WELD'T |
| 2 | 1 | 8048567 | STRAIGHT SPRAY GUN |
| 3 | 1 | 8030391 | BANJO 3" MALE FNPT |
| 4 | 1 | T401100 | ELBOW 4MP 4MJ 90 |
| 5 | 1 | T401065 | ELBOW, 3/8 MP - 3/8 FP |
| 6 | 1 | T400023 | REDUCER 6MP 4FP |
| 7 | 1 | 8030486 | WATER QD 1/4 MNPT SS |
| 8 | 1 | 8042855 | CLAMP HOSE T-BOLT 375 |
| 9 | 1 | 8042605 | CLAMP HOSE T-BOLT 350 |
| 10 | 1 | 8044096 | PVC 3" DIA X 9" LONG |
| 11 | 1 | 8030669 | REDUCER PVC 3" TO 2" SLIP ON |
| 12 | 1 | U010019 | U-BOLT 1_4-20 X 3_4 WIDE X 2 1_4 LONG |
| 13 | 1 | 8044097 | PVC 2" DIA X 42.5" LG |
| 14 | 1 | 8031246 | NOZZLE, .100 X 0 DEG |
| 15 | 1 | T422010 | COUPLING 1/4"FP |
| 16 | 1 | U400020 | UNION, 1/4" MP - 1/4" MJ |
| 17 | 1 | 8044098 | HOSE ASSY VALVE BOX CLEANOUT TOOL |
| 18 | 2 | 8045316 | CLAMP, HOSE T-BOLT 275 |

Tools

Rotary Lance

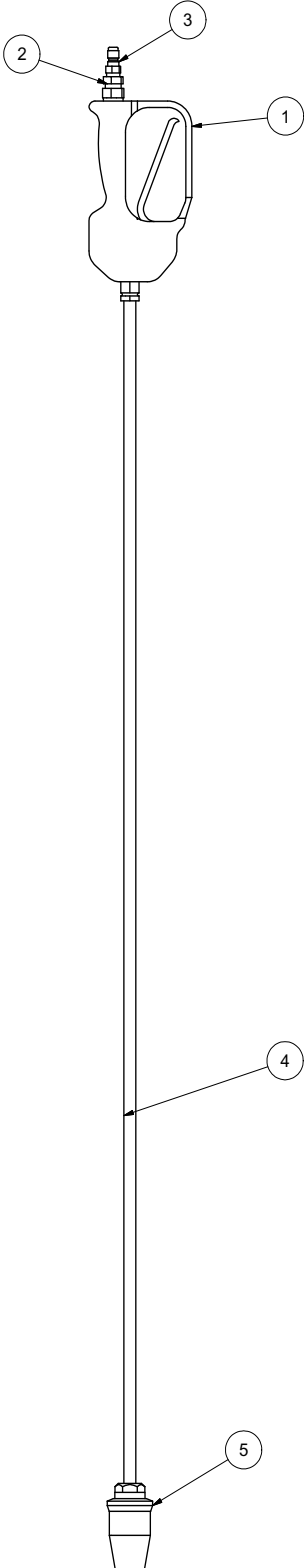

040913-E

VACASSY716

Tools

Rotary Lance

| ITEM | QTY | PART NO. | DESCRIPTION |
|-------------|------------|-----------------|--------------------------------|
| * | | 8043119 | TOOL VAC ROTARY LANCE COMPLETE |
| 1 | 1 | 8048567 | STRAIGHT SPRAY GUN |
| 2 | 1 | T400023 | UNION 6MP-4FP |
| 3 | 1 | 8030486 | WATER QD 1/4MNPT SS |
| 4 | 1 | 8043765 | TUBE,CHROME 1/4NPT ENDS 60" |
| 5 | 1 | 8042691 | ROTARY WOBBLE NOZZLE .080 |

Tools

Hot Box Rotary Lance

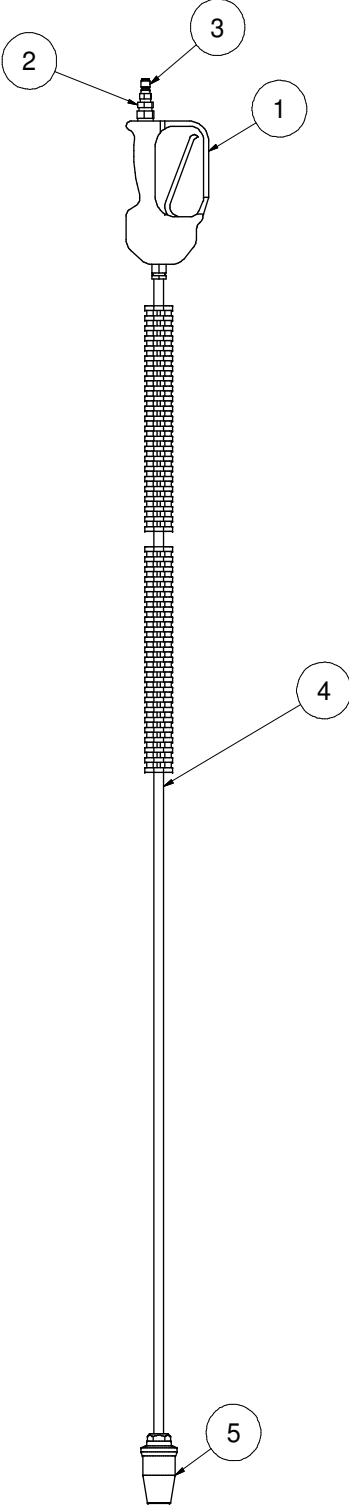

Tools

Hot Box Rotary Lance

| ITEM | QTY | PART NO. | DESCRIPTION |
|------|-----|----------|--|
| * | | 8048192 | TOOL VAC ROTARY LANCE for HOT BOX COMPLETE |
| 1 | 1 | 8048567 | STRAIGHT SPRAY GUN |
| 2 | 1 | T400023 | UNION 6MP-4FP |
| 3 | 1 | 8030486 | WATER QD 1/4MNPT SS |
| 4 | 1 | 8031394 | WAND, 59" LONG |
| 5 | 1 | 8042691 | ROTARY WOBBLE NOZZLE .080 |

040913-E

VACASSY718

Tools

Lawn Sweeper 3''

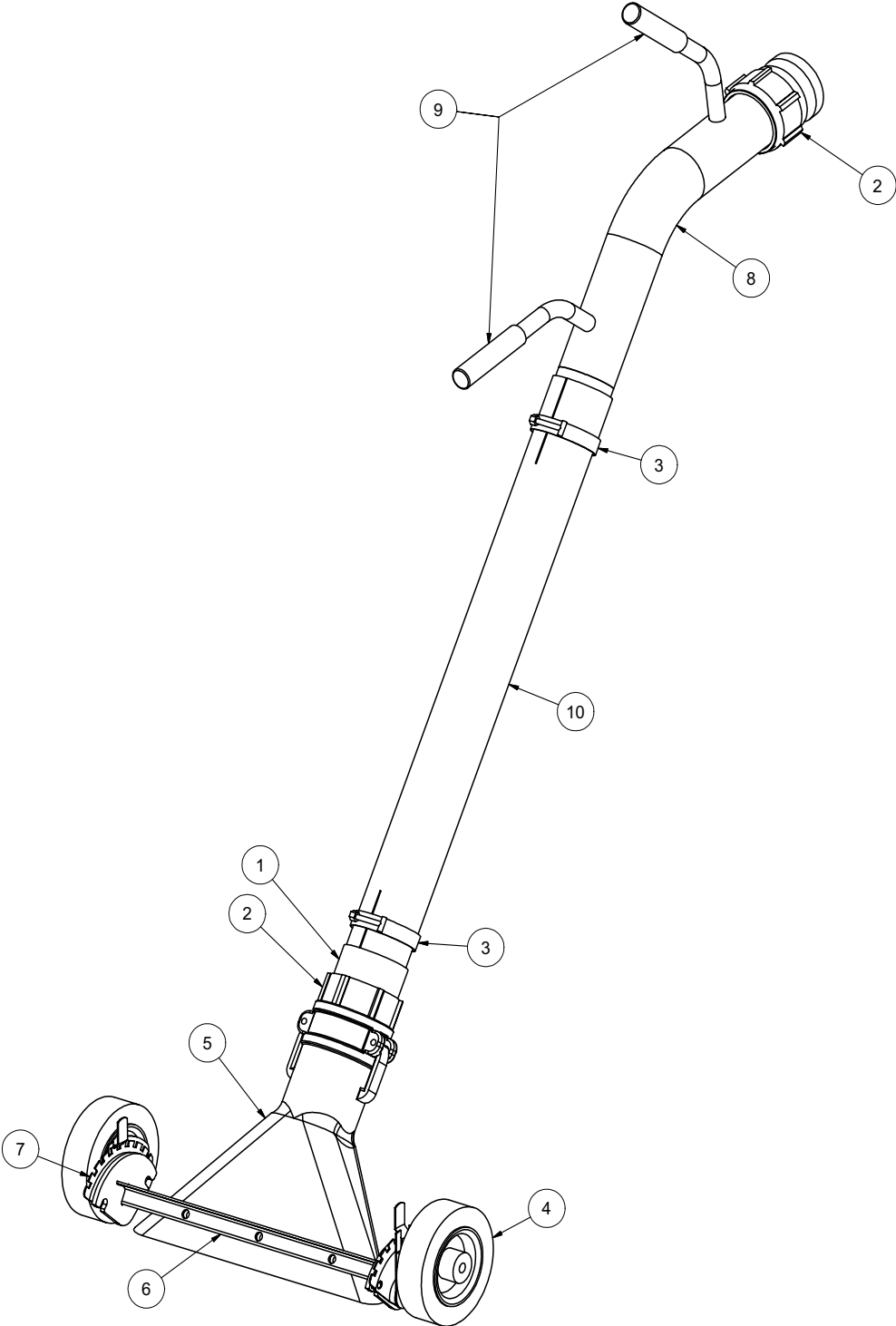

101512-E

VACASSY713

Tools

Lawn Sweeper 3''

| ITEM | QTY | PART # | DESCRIPTION |
|------|-----|---------|---------------------------------|
| | 1 | 8043935 | VAC TOOL LAWN SWEEPER COMPLETE |
| 1 | 1 | 8030287 | 3" HOSE X 3" MNPT ADAPTER |
| 2 | 2 | 8030391 | BANJO 3" MALE 3" FNPT |
| 3 | 2 | 8042605 | CLAMP T-BOLT 3" (350) |
| 4 | 2 | 8043887 | WHEEL 6" PNEUMATIC |
| 5 | 1 | 8043925 | DUCKBILL 3" ALUMINUM |
| 6 | 1 | 8043928 | LS WHEEL WELDMENT |
| 7 | 1 | 8043931 | WHEELADJUSTERS (1 LEFT/1 RIGHT) |
| 8 | 1 | 8043933 | LS HANDLE WELDMENT |
| 9 | 2 | J300080 | HANDLE GRIP |
| 10 | 1 | 8043932 | PVC 3" X 30" |

101512-E

VACASSY713

Surface Cleaner

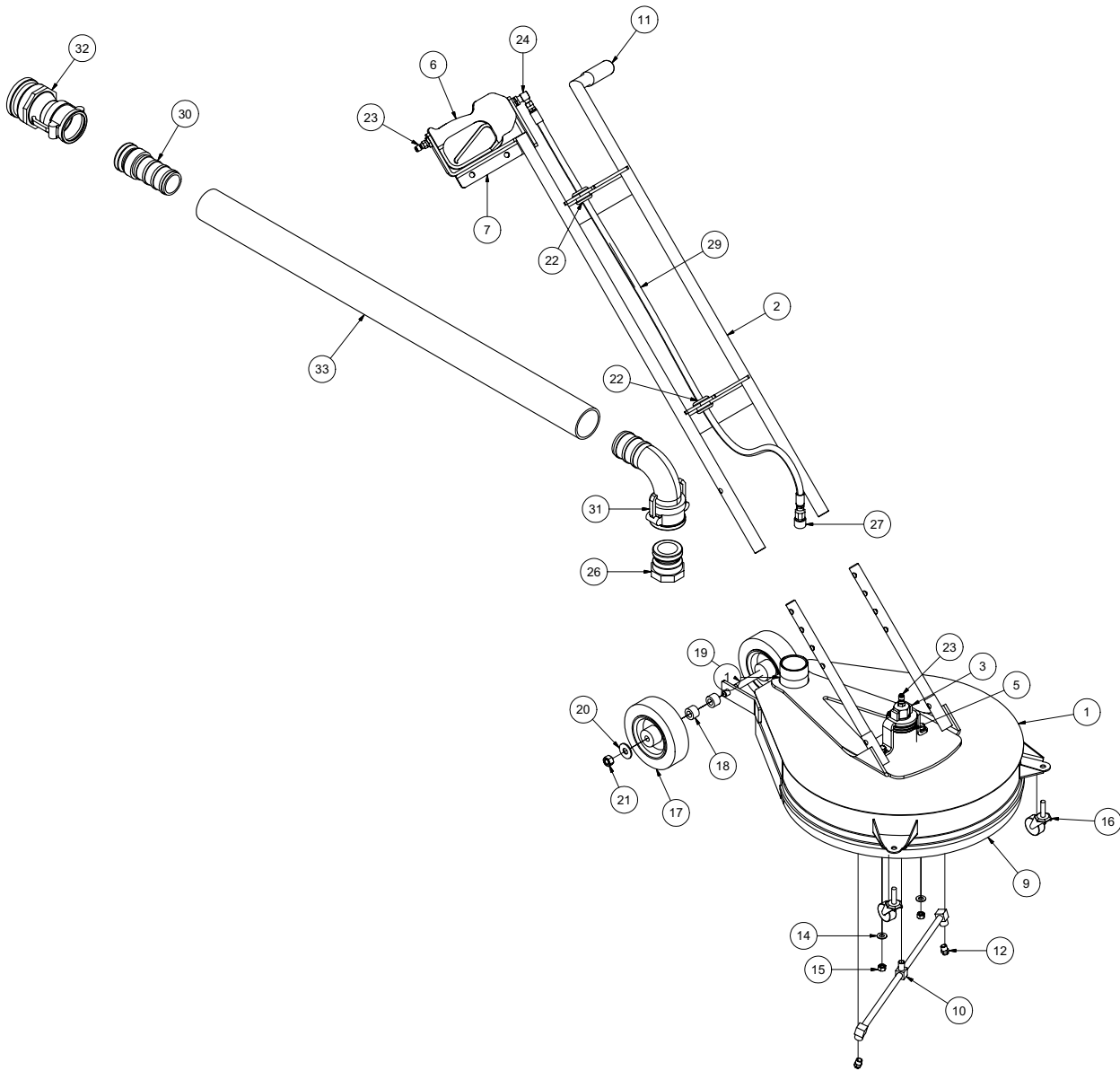

101812-E

VACASSY715

Surface Cleaner

| ITEM | QTY | PART NO. | DESCRIPTION |
|------|-----|----------|-----------------------------------|
| | 1 | 8043480 | VAC TOOL SURFACE CLEANER COMPLETE |
| 1 | 1 | 8041887 | SURFACE CLEANER - HEAD ASSY |
| 2 | 1 | 8042019 | HANDLE ASSY |
| 3 | 1 | 8041890 | ROTARY RETAINER |
| 4 | 2 | 8042022 | HANDLE ADJ. TUBE |
| 5 | 1 | 8042027 | ROTARY HEAD |
| 6 | 1 | 8048567 | STRAIGHT SPRAY GUN |
| 7 | 1 | 8042020 | GUN CAPTURE BRACKET |
| 8 | 1 | 8043467 | SQUEEGEE |
| 9 | 1 | 8042030 | FLEXIBLE BRUSH |
| 10 | 1 | 8042028 | ROTARY ARM |
| 11 | 1 | J300080 | GRIPHANDLE |
| 12 | 2 | 8031419 | NOZZLE, #4.0 25 DEG |
| 13 | 2 | U000420 | SCREW, HC 3/8-16 X 1.00 |
| 14 | 4 | U200600 | WASHER, FLAT 3/8" |
| 15 | 2 | U100060 | NUT, HEX 3/8-16 |
| 16 | 2 | 8043387 | SWIVEL CASTER 1 5/8" |
| 17 | 2 | 8043887 | WHEEL 6" PNEUMATIC |
| 18 | 2 | 8043591 | SURFACE CLEANER REAR WHEEL SPACER |
| 19 | 1 | U001060 | SCREW, HC 1/2-13 X 6.0 |
| 20 | 2 | U200100 | WASHER, FLAT 1/2" |
| 21 | 1 | U120120 | NUT, LOCK 1/2-13 |
| 22 | 2 | 8041686 | GROMMET 1"ID- 1 1/4"DOG-1/4"WO |
| 23 | 2 | 8030486 | WATER QD 1/4 MNPT SS |
| 24 | 1 | T401100 | ELBOW 4MP 4MJ 90 |
| 25 | 1 | T320030 | FITTING, HOSE 4HO 4FJ |
| 26 | 1 | 8043389 | ADAPTER M2" F THREAD |
| 27 | 1 | 8030526 | FITTING, QD WATER 1/4"F-1/4"FP |
| 28 | 1 | T320300 | FITTING, HOSE 4HO 4MP |
| 29 | 1 | 8044108 | HOSE VAC SURFACE CLEANER |
| 30 | 1 | 8043392 | ADAPTER M2" F THREAD |
| 31 | 1 | 8043391 | REDUCER COUPLER 2"F 90 DEG - 3"M |
| 32 | 1 | 8043395 | REDUCER COUPLER 2" X 3" ADAPTER |
| 33 | 1 | 8043398 | HOSE VAC CLEAR 2" |
| * | 2 | 8043397 | CLAMP VAC CLEAR HOSE 2" |
| * | 4 | U360020 | PIN, U-LOCK 3/8 X 1.5 |

EXTENSION ARM

BOOM

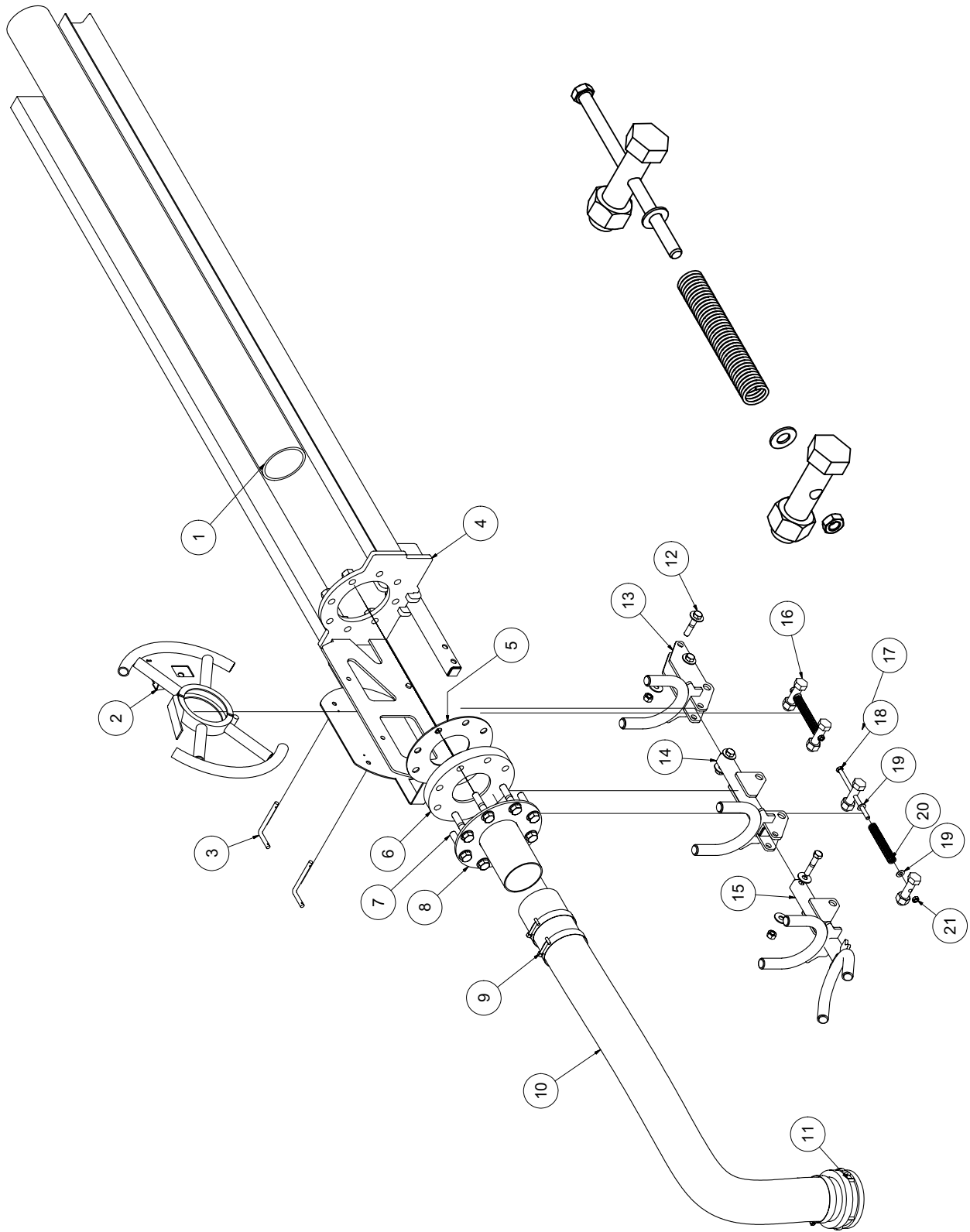

121310-E

VACASSY989

EXTENSION ARM

BOOM

| ITEM | QTY | NUMBER | DESCRIPTION |
|------|-----|---------|-------------------------------------|
| 1 | 1 | 8042160 | BOOM - PVC TUBE 4 X 60" |
| 2 | 1 | 8043647 | BOOM HANDLE WELDMENT |
| | 2 | 8042971 | RUBBER STRIP |
| 3 | 2 | 8043947 | CAPTURE PIN |
| | 2 | R700160 | R-CLIP |
| | 2 | 8041485 | LANYARD CABLE |
| 4 | 1 | 8046591 | BOOM - EXTENSION ARM WELDMENT |
| 5 | 1 | 8041938 | GASKET, FLANGE 4" |
| 6 | 1 | 8041937 | 4" PVC FLANGE |
| 7 | 8 | U001250 | SCREW, HC 5/8" - 11 X 3.00" |
| | 16 | U200140 | WASHER, FLAT 5/8" |
| | 8 | U120020 | NUT, NYLOCK 5/8" - 11 |
| 8 | 1 | 8046638 | BOOM - HOSE MOUNT PLATE WELDMENT |
| 9 | 3 | 8042606 | CLAMP, T-BOLT 4" (450) |
| 10 | 1 | 8047019 | HOSE VAC AG SUCTION 4-45" |
| 11 | 1 | 8046444 | CAMLOCK, 4" MCAM X MBARB |
| 12 | 4 | U000900 | SCREW, 1/2" - 13 X 2 1/2" HHCS |
| | 8 | U200100 | WASHER, FLAT 1/2" |
| | 4 | U120120 | NUT, LOCK 1/2" - 13 |
| 13 | 1 | 8046612 | BOOM - END PIVOT WELDMENT # 3 |
| 14 | 1 | 8046603 | BOOM - END PIVOT WELDMENT # 1 |
| 15 | 1 | 8046606 | BOOM - END PIVOT WELDMENT # 2 |
| 16 | 4 | 8046636 | BOOM - SPRING BOLT |
| | 4 | U100200 | NUT, HEX 3/4" - 10 |
| 17 | 1 | 8046771 | SPRING, 3/8" - 5.00", 480lb per in |
| 18 | 2 | U000635 | SCREW, HC .375 - 16 X 6.50" ZP CR5 |
| 19 | 4 | U200600 | WASHER, FLAT 3/8" |
| 20 | 1 | 8046770 | SPRING, 3/8" X 5.00", 395 lb per in |
| 21 | 2 | U120110 | NUT, HEX LOCK |

PIVOT ARM

BOOM

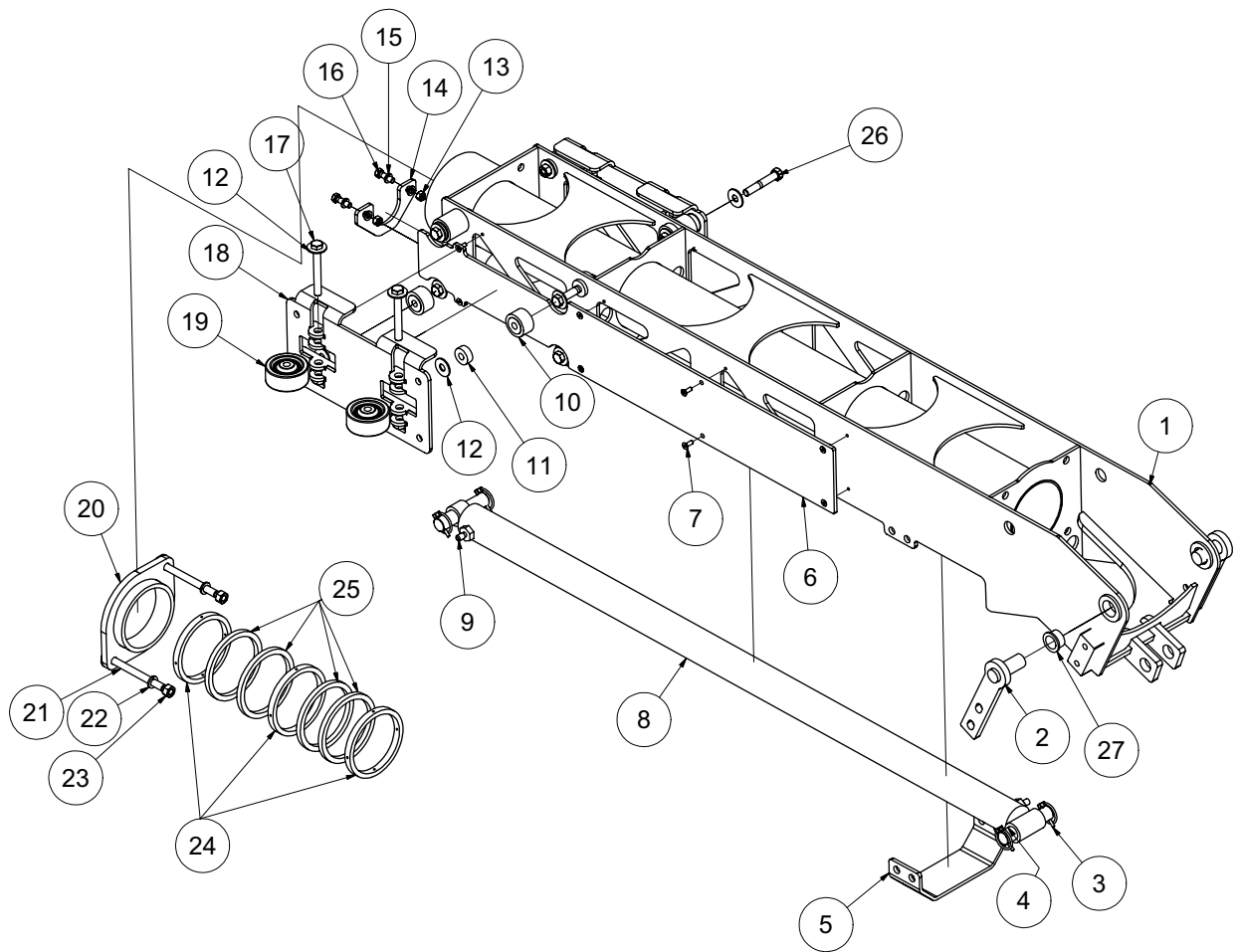

081910-E

VACASSY989

PIVOT ARM

BOOM

| ITEM | QTY | NUMBER | DESCRIPTION |
|------|-----|---------|-------------------------------------|
| 1 | 1 | 8046582 | BOOM - PIVOT ARM WELDMENT |
| 2 | 2 | 8046634 | BOOM - PIVOT PIN WELDMENT |
| 3 | 4 | U340050 | PIN LINCH 3/16" X 1 9/16" |
| 4 | 2 | 8041990 | BOM - PIVOT CYLINDER ROD PIN |
| 5 | 1 | 8046635 | BOOM - CRADEL FOOT PLATE |
| 6 | 2 | 8041986 | BOOM - PIVOT ARM GUIDE SHEET |
| 7 | 16 | U030015 | SCREW, SFH 1/4-20 X .750 |
| 8 | 1 | 8041926 | BOOM - CYLINDER WX |
| 9 | 2 | T400611 | REDUCER, 1/2"MB - 1/4"MJ |
| 10 | 4 | W000055 | CAM YOKE ROLLER 1 3/4"DIA X 1.00" |
| 11 | 4 | 8046624 | BOOM - CAM SPACER |
| 12 | 14 | U200100 | WASHER, FLAT 1/2" |
| 13 | 2 | U100060 | NUT, HEX 3/8"-16 |
| 14 | 1 | 8041956 | BOOM - PIVOT ARM CYC RETAINER PLATE |
| 15 | 4 | U210060 | WASHER, LOCK 3/8" |
| 16 | 2 | U000440 | SCREW, HC 3/8"-16 X 1.25" |
| 17 | 4 | 8046773 | SCREW, BOOM EXT. CAPTURE PLATE |
| 18 | 2 | 8046627 | BOOM - EXT. CAPTURE PLATE WELDMENT |
| 19 | 4 | 8030226 | WHEEL 3.00"OD X 1.25" WIDE W / BRG |
| 20 | 1 | 8041963 | PACKING GLAND WELDMENT |
| 21 | 2 | U001020 | SCREW, HC .50"-13 X 5.50"ZP GR5 |
| 22 | 2 | U210111 | WASHER, LOCK 1/2" |
| 23 | 2 | U100120 | NUT, HEX 1/2-13 |
| 24 | 3 | 8041945 | SLEEVE PLASTIC |
| 25 | 4 | 8041947 | PACKING RING |
| 26 | 8 | U000940 | SCREW, HC .500-13X3.50 |
| | 16 | U200110 | WASHER, FLAT .500 |
| | 8 | U120120 | NUT, LOCK .500 - 13 |
| 27 | 2 | 8041883 | BUSHING, BRONZE FLANGED 1" |

TURRET

BOOM MANUAL ROTATION REV. FLOW

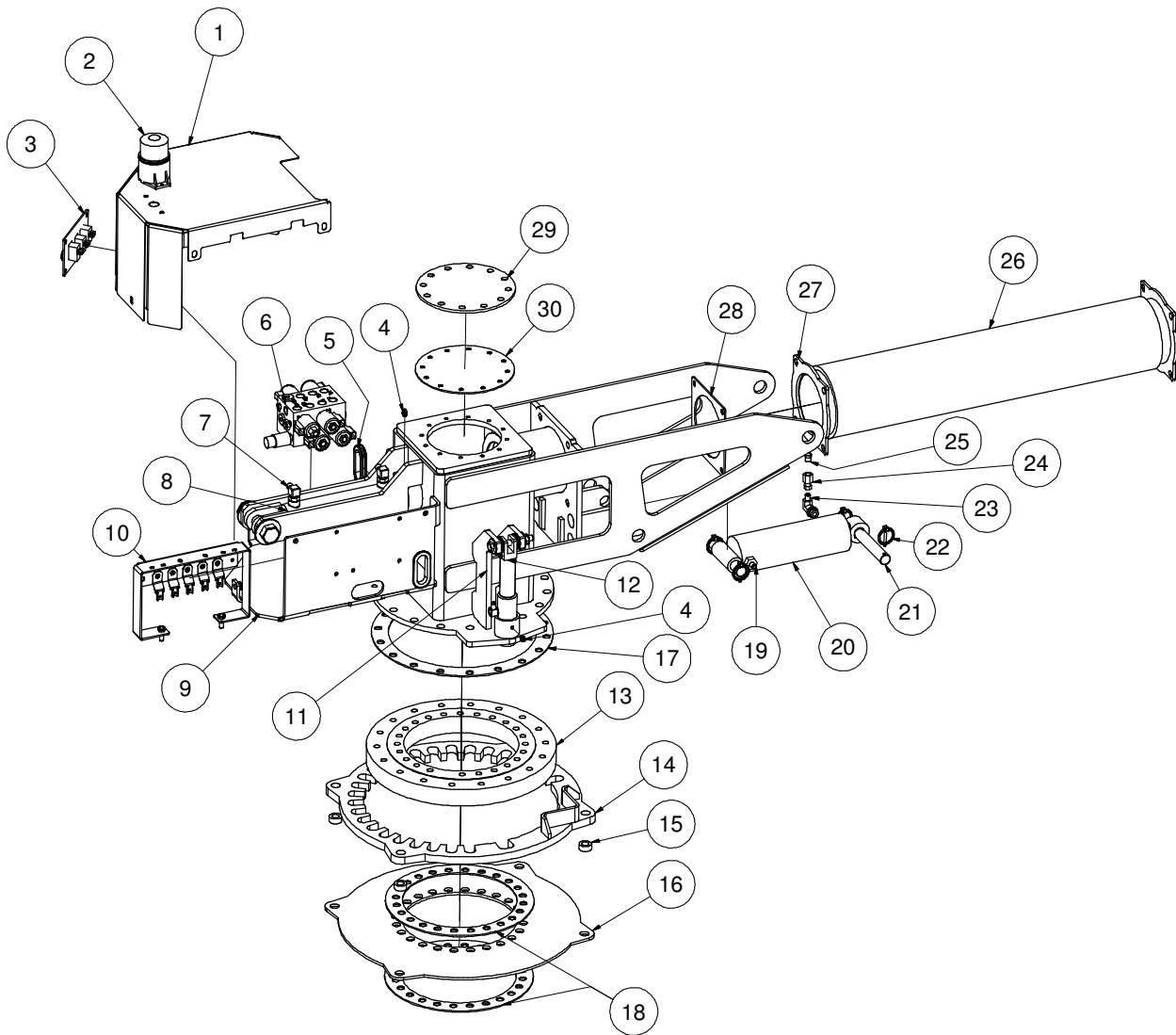

121212-E

VACASSY989-1

TURRET

BOOM MANUAL ROTATION REV. FLOW

| ITEM | QTY | PART # | DESCRIPTION |
|------|-----|---------|---|
| 1 | 1 | 8046644 | BOOM - COVER WELDMENT |
| * | 5 | U000400 | SCREW, HC 3/8"-16 X .75 |
| * | 5 | U000440 | WASHER, FLAT 3/8" |
| 2 | 1 | 8043139 | LIGHT STROBE LED DEUTSCH |
| 3 | 1 | 8046696 | PANEL CONTROL BOOM OVERRIDE |
| | 1 | X000274 | SWITCH, ROCKER (UP / DOWN) |
| | 1 | X000274 | SWITCH, ROCKER (EXTEND / RETRACT) |
| | 1 | X000273 | SWITCH, ROCKER (BRAKE) |
| 4 | 2 | T500030 | GREASE FITTING 1/8"NPT STRAIGHT |
| 5 | 4 | 8042812 | GROMMET 2"ID 3"OD 1/4"WOG TRAILER SLOT MODEL |
| 6 | 1 | 8047331 | MANIFOLD ASSY BOOM (CROSS2) |
| 7 | 2 | T401265 | ELBOW, 90 1/2"MB - 1/4"MJ |
| 8 | 1 | 8048198 | BOOM GATE VALVE CYLINDER |
| | 2 | W201020 | WIPER, CYLINDER ROD, 1 1/8" ROD |
| | 1 | 8044480 | SEAL PLATE WELDMENT |
| | 1 | 8044482 | BOOM SHUTOFF SEAL |
| | 1 | 8044483 | BOOM SHUTOFF SEAL PLATE SHIELD |
| | 1 | U001570 | SCREW, HC 1"-8 X 5.00 |
| | 1 | U120060 | NUT, LOCK NY 1 - 8 |
| 9 | 1 | 8046571 | BOOM TURRET WELDMENT |
| | 6 | U001281 | SCREW, HC .625 - 11 X 3.50" |
| | 6 | U120020 | NYLON LOCK NUT .625 - 11 |
| | 12 | U200140 | WASHER, FLAT .625 |
| 10 | 1 | 8046764 | BOOM ELECTRICAL BRACKET LP |
| | 5 | X000320 | DEUTSH DIODE RECEPTACLE |
| | 1 | 8040185 | RELAY |
| | 2 | 8044912 | TIME RELAY |
| 11 | 1 | 8045157 | BOOM MANUAL BRAKE WELDMENT |
| 12 | 1 | 8043052 | BRAKE, CYLINDER |
| | 1 | T401100 | ELBOW, 4MP-4MJ, 90 |
| 13 | 1 | 8042234 | SWIVEL BEARING |
| | 3 | T500020 | FITTING, GREASE .125 STRAIGHT (2 IN INNER RING, 1 IN OUTER RING) |
| | 18 | U001195 | SCREW, HC 5/8"-11 X 1 3/4" |
| | 23 | U001210 | SCREW, HC 5/8"-11 X 2 1/4" |
| | 41 | U200140 | WASHER, FLAT 5/8" |
| | 41 | U210140 | WASHER, LOCK 5/8" |
| 14 | 1 | 8046688 | BOOM MOUNT BRAKE RING |
| | 4 | U001900 | SCREW, HC 5/8"-11 X 2 1/2" |
| | 8 | U200140 | WASHER, FLAT 5/8" |
| | 4 | U120140 | NUT, LOCK 5/8"-11 |
| 15 | 4 | 8030315 | SKID - WATER TANK CLEVIS TUBE |
| 16 | 1 | 8046690 | BOOM - LOWER STOP RING |
| 17 | 1 | 8043780 | GASKET BOOMBRG TOP |
| 18 | 2 | 8043781 | GASKET BOOMBRG BOT |
| 19 | 1 | T400611 | UNION, 8MB - 4MJ |
| 20 | 1 | 8046597 | CYLINDER, HYD BOOM 3 X 6 |
| 21 | 2 | 8041977 | BOOM - PIVOT CYLINDER BASE PIN |
| 22 | 4 | U340050 | PIN LINCH 3/16 X 1 9/16" |
| 23 | 1 | T401265 | ELBOW, 90 1/2"MB - 1/4"MJ |
| 24 | 1 | T400082 | UNION, 1/4"FP - 1/4"FJ |
| 25 | 1 | T400801 | FITTING, VENTED CAP 1/4" - 18NPTF |
| 26 | 1 | 8042103 | HOSE AG SUCTION 6 - 32 1/2" |
| | 2 | 8042104 | CLAMP, HOSE T-BOLT 6.75 |
| 27 | 2 | 8041958 | BOOM - FLEX HOSE ADAPTER WELDMENT |
| 28 | 2 | 8041988 | BOOM - FLANGE GASKET |
| 29 | 1 | 8044471 | BOOM TURRET SHUTOFF - CLEAN COVER |
| 30 | 1 | 8044475 | BOOM TURRET SHUTOFF - CLEAN COVER GASKET |

121212-E

VACASSY989-1

BOOM REMOTE CONTROL (AUS) GENERATION C2 - KT - MANUAL

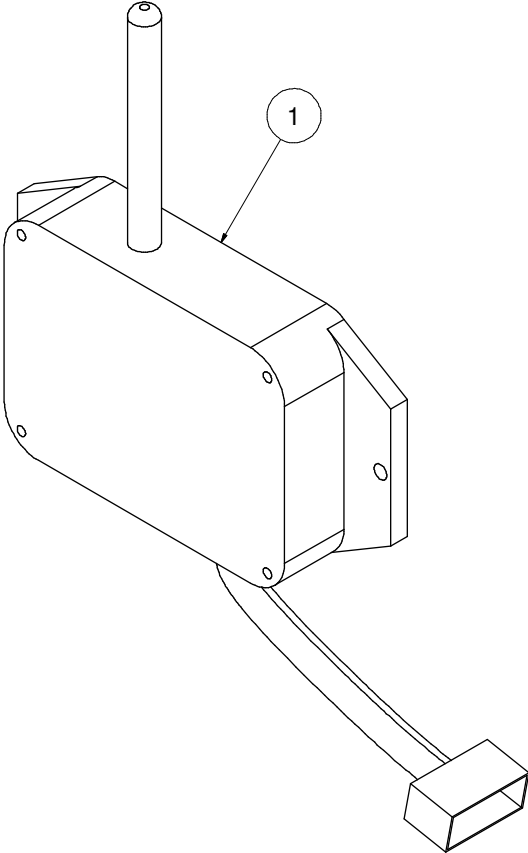
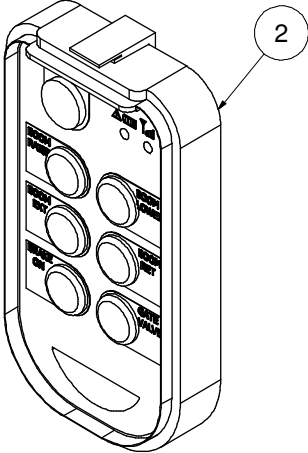

BOOM REMOTE CONTROL (AUS) GENERATION C2 - KT - MANUAL

| ITEM | QTY | PART # | DESCRIPTION |
|------|-----|---------|------------------------------------|
| 1 | 1 | 8048610 | BOOM - RC RECEIVER |
| 2 | 1 | 8048600 | REMOTE CONTROL BOOM MR ORG-AUS |
| * | 1 | X200060 | HARNESS VAC BOOM UPPER |
| * | 1 | X200040 | HARNESS VAC BOOM LOWER |
| * | 1 | 8048777 | SYSTEM OPERATION & TROUBLESHOOTING |

BOOM REMOTE CONTROL (US) GENERATION C2 - KT - MANUAL

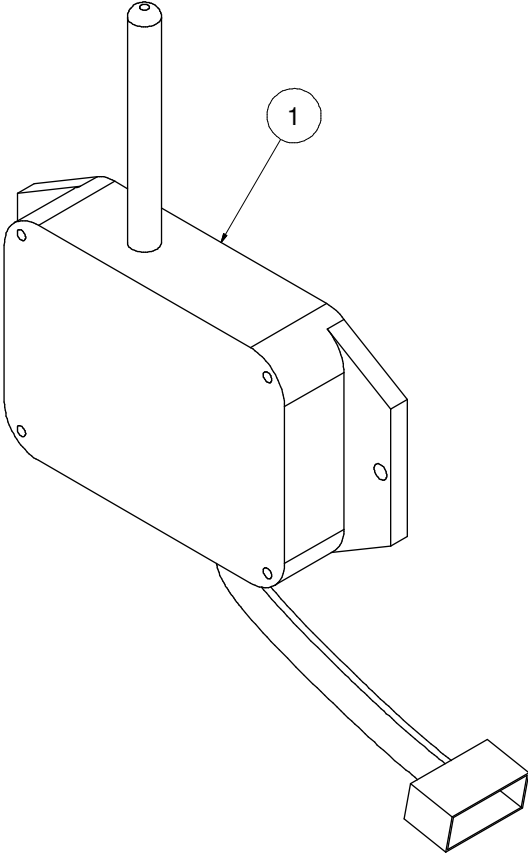
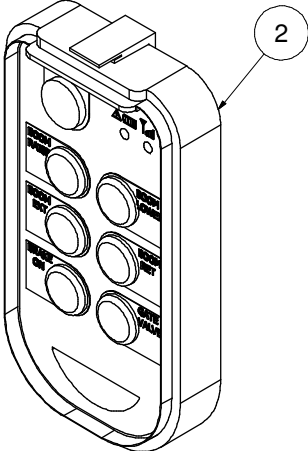

BOOM REMOTE CONTROL (US) GENERATION C2 - KT - MANUAL

| ITEM | QTY | PART # | DESCRIPTION |
|------|-----|---------|------------------------------------|
| 1 | 1 | 8048310 | BOOM - RC RECEIVER |
| 2 | 1 | 8048300 | REMOTE CONTROL BOOM MR ORG-US |
| * | 1 | X200060 | HARNESS VAC BOOM UPPER |
| * | 1 | X200040 | HARNESS VAC BOOM LOWER |
| * | 1 | 8048777 | SYSTEM OPERATION & TROUBLESHOOTING |

HOSE STORAGE

BOOM

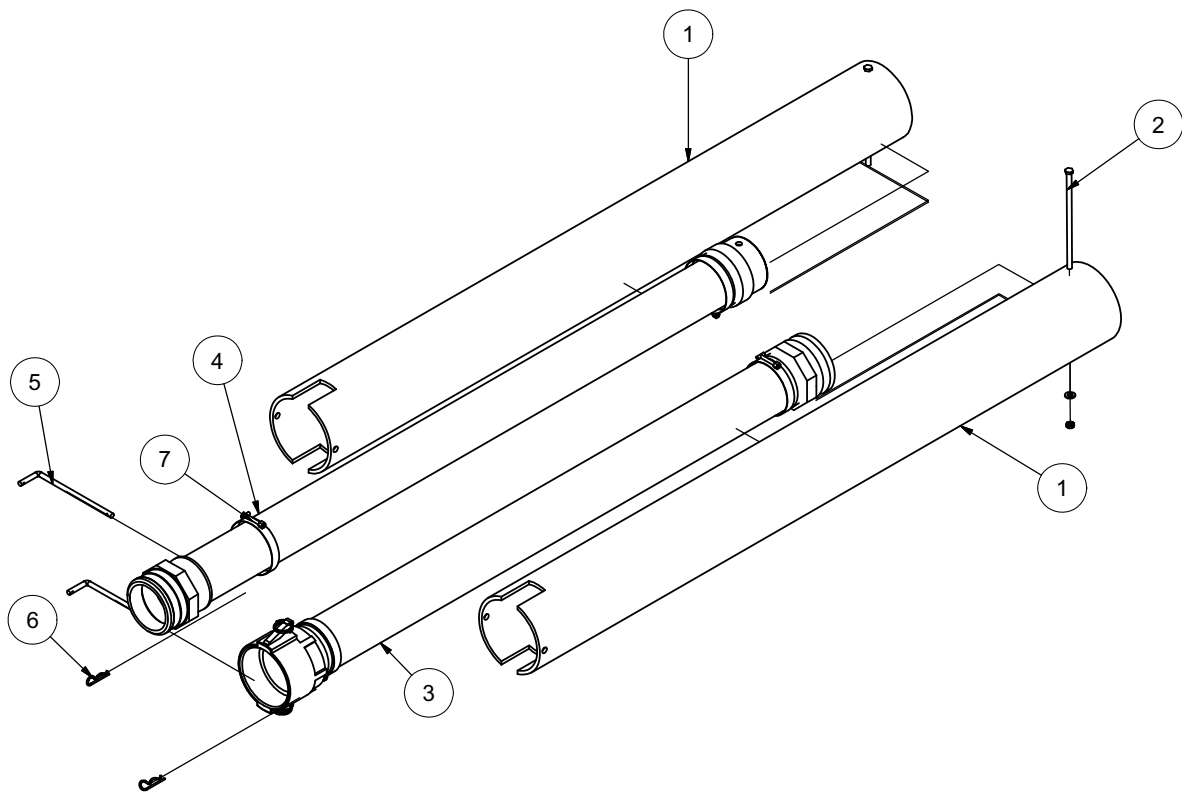

060311-E

VACASSY978

HOSE STORAGE

BOOM

| ITEM | QTY | NUMBER | DESCRIPTION |
|------|-----|---------|---------------------------------------|
| 1 | 2 | 8042222 | BOOM EXTENSION HOSE STORAGE |
| | 2 | 8043198 | CLAMP T-BOLT 700 |
| 2 | 2 | U000626 | SCREW, HC 3/8"-16 X 7.50" |
| | 1 | U200060 | WASHER, FLAT 3/8" |
| | 1 | U120110 | NUT, LOCK .375-16 |
| 3 | 1 | 8042137 | BOOM HOSE EXTENSION |
| | 1 | 8041781 | BOOM EXTENSION HOSE |
| | 2 | 8045239 | UNION EXHAUST 4"OD - MNPT |
| | 1 | 8030846 | 4" FEMALE COUPLER |
| | 1 | 8030844 | 4" MAL COUPLER |
| 4 | 1 | 8032138 | BOOM HOSE EXTENSION WITH 4" UNION PVC |
| | 1 | 8045723 | 4" ALUMINUM TUBE 52 1/2"LG |
| | 2 | 8045728 | 4" HALF NIPPLE |
| | 1 | 8030844 | COUPLING, 4" ALUM CAMLOCK MXF |
| | 1 | 8045725 | UNION PVC 4"FNPT 4"MSLIP w/HOLE |
| 5 | 2 | 8041101 | HOSE STORAGE RETAINING ROD |
| | 2 | 8041485 | LANYARD CABLE |
| 6 | 2 | R700160 | R-CLIP |
| | 4 | 8042606 | CLAMP T-BOLT 450 |

Hot Box Assembly

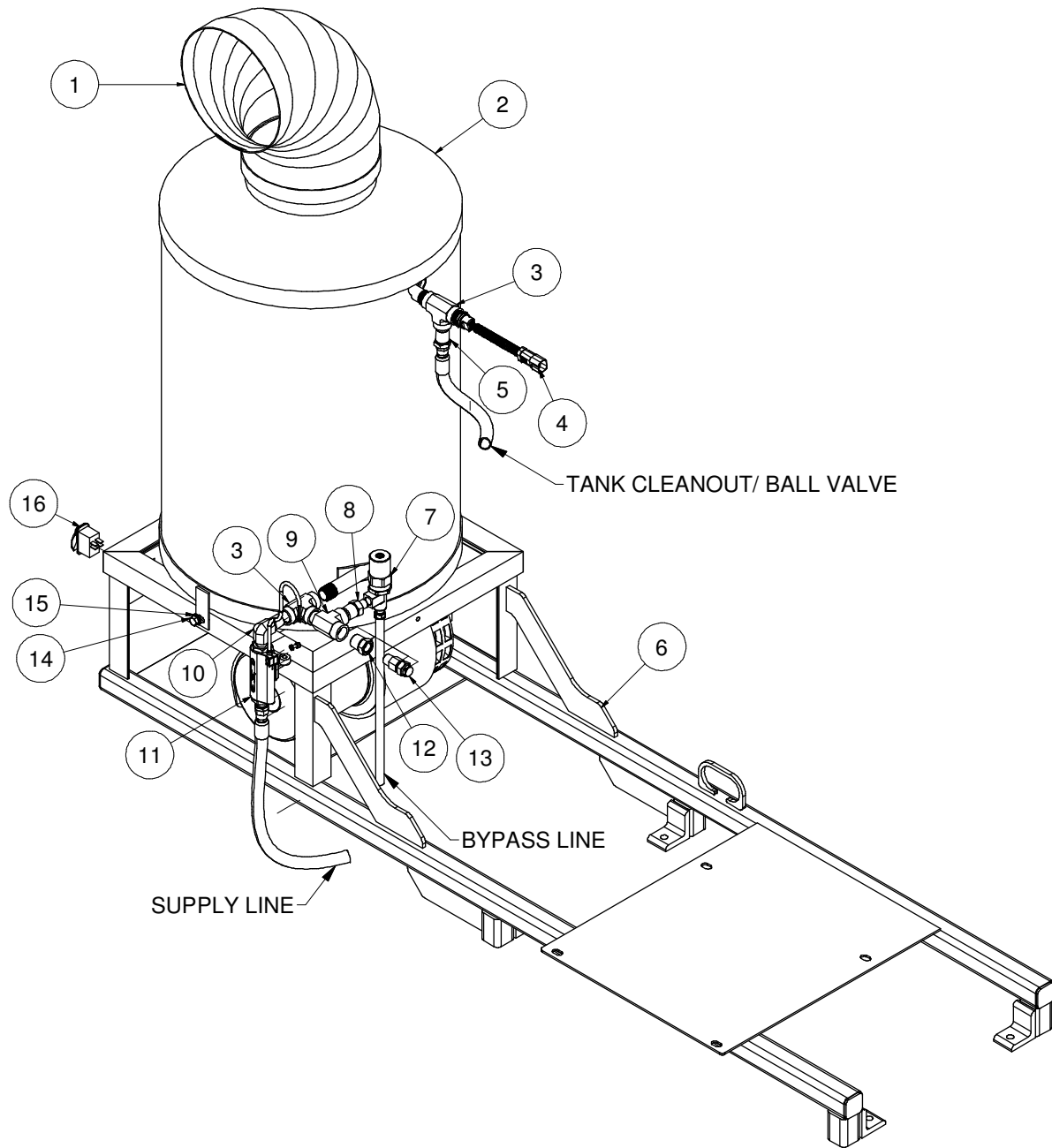

Hot Box Assembly

| ITEM | QTY | NUMBER | DESCRIPTION |
|------|-----|---------|--|
| 1 | 1 | 8046535 | 8" ELBOW EXHAUST (AQUA-BLAST) |
| 2 | 1 | 8046448 | HOT BOX, VERTICAL |
| 3 | 2 | T402130 | ADAPTER, TEE 8FP - 8FP - 8FP GALV |
| 4 | 1 | 8048033 | TEMPERTURE SWITCH .50NPTM 100 & 165 DEG |
| 5 | 1 | 8031291 | ADAPTER STR. 8MP - 6MJ GALV. |
| 6 | 1 | 8046664 | AIR FILTER HOT BOX BRACKET LE |
| 7 | 1 | 8048030 | VALVE PRESSURE REGULATING 5075PSI 8GPM |
| 8 | 1 | T400123 | FITTING, 1/2"MP - 1/4"MP |
| 9 | 1 | T402156 | ADAPTER, TEE 8MP - 8MP - 8FP GALV |
| 10 | 1 | T401136 | ELBOW, 90 8MP - 6MP |
| 11 | 1 | 8047724 | SWITCH, FLOW 3/8FP, GRAVITY ACTUATED |
| 12 | 1 | T400024 | ADAPTER STR. 8MP - 6FP |
| 13 | 1 | 8046976 | VALVE PRESSURE RELIEF BURST DISK 5000PSI |
| 14 | 3 | U200020 | SCREW, HC 5/16" - 18 X 1.00 |
| 15 | 3 | U200040 | WASHER, FLAT 5/16" |
| 16 | 1 | X000271 | SWITCH, HIGH/LOW |
| * | 1 | J200062 | DECAL HOT BOX TEMP HI-LO |
| * | 1 | X200047 | HARNESS HOT BOX SWITCH SIDE |
| * | 1 | X200048 | HARNESS HOT BOX POWER SIDE |

* ITEM NOT SHOWN

Hose Reel Assembly

(Jetter)

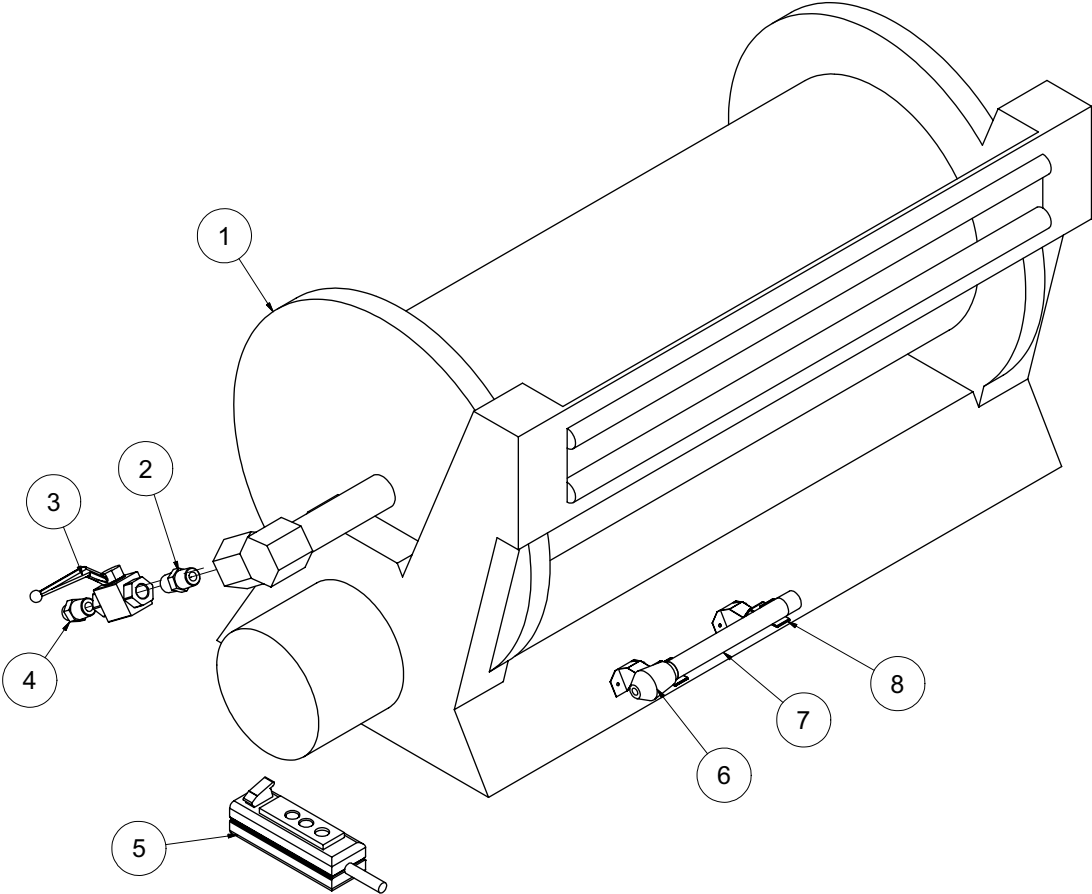

081610-E

VACASSY766

Hose Reel Assembly

(Jetter)

| ITEM | QTY | NUMBER | DESCRIPTION |
|------|-----|---------|-------------------------------|
| 1 | 1 | 8043214 | REEL ONLY JETTER 1/2" X 500' |
| 2 | 1 | T404020 | UNION, 8MP - 8MP |
| 3 | 1 | 8031197 | STEEL BALL VALVE - 1/2"NPT |
| 4 | 1 | T400040 | UNION, 8MP - 8MJ |
| 5 | 1 | 8030859 | HANDSET CONTROLLER (JETTER) |
| 6 | 1 | 8040546 | JETTER NOZZLE 12GPM |
| 7 | 1 | 8032013 | NIPPLE, STAINLESS 1/2"MP X 8" |
| 8 | 1 | 8040899 | CLIP, TOOL HOLDER |

081610-E

VACASSY766

Hose Reel (Jetter)

Components

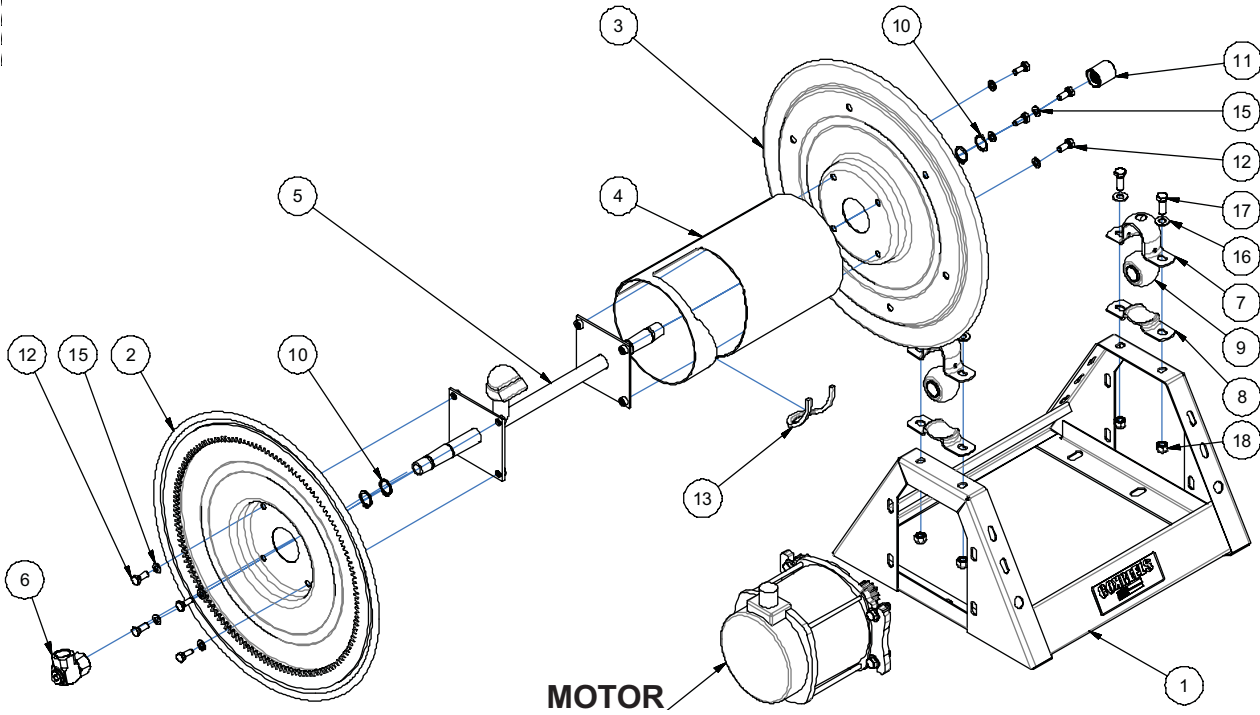

MOTOR ASSEMBLY

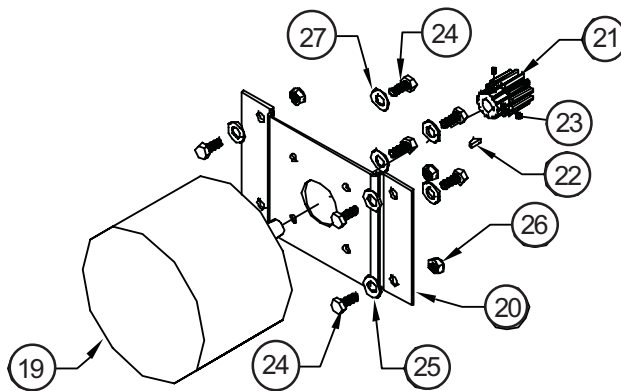

081010-E

VACASSY765

Hose Reel

Components

| ITEM | QTY | NUMBER | DESCRIPTION |
|------|-----|------------|------------------------------|
| | | 8043214 | REEL ONLY JETTER 1/2" X 500' |
| 1 | 1 | 8043214-1 | REEL, JETTER FRAME |
| 2 | 1 | 8043214-2 | DISC, SWV SIDE |
| 3 | 1 | 8043214-3 | DISC, CRK SIDE |
| 4 | 1 | 8043214-4 | CENTER DRUM |
| 5 | 1 | 8043214-5 | AXLE ASSEMBLY |
| 6 | 1 | 8043214-6 | SWIVEL |
| 7 | 2 | 8043214-7 | PILLOW BLOCK, MTG, TOP |
| 8 | 2 | 8043214-8 | PILLOW BLOCK, MTG, BOTTOM |
| 9 | 2 | 8043214-9 | BEARING |
| 10 | 4 | 8043214-10 | R. RING |
| 11 | 1 | 8043214-11 | ASSY, LOCK PIN |
| 12 | 10 | 8043214-12 | BOLT, 5/16" - 18 X 3/4" LG |
| 13 | 1 | 8043214-13 | TRIM |
| 15 | 8 | 8043214-15 | WASHER, LOCK 5/16" |
| 16 | 4 | 8043214-16 | WASHER, FLAT 3/8" |
| 17 | 4 | 8043214-17 | BOLT, 3/8"-16 X 1" LG |
| 18 | 4 | 8043214-18 | NUT, LOCKING 3/8" |
| 19 | 1 | 8043214-19 | MOTOR, 12VDC |
| 20 | 1 | 8043214-20 | BRACKET, 12VDC MOTOR |
| 21 | 1 | 8043214-21 | PINION GEAR |
| 22 | 1 | 8043214-22 | KEY |
| 23 | 2 | 8043214-23 | SCREW, SET |
| 24 | 8 | 8043214-24 | BOLT, 5/16" - 18 X 3/4" |
| 25 | 4 | 8043214-25 | WASHER, FLAT 5/16" |
| 26 | 4 | 8043214-26 | NUT, LOCKING 5/16 - 18 |
| 27 | 4 | 8043214-27 | WASHER, LOCK 5/16" |

081010-E

VACASSY765

Arrow Board Option

ARROW BOARD & DUST COVER
NOT DRAWN TO SCALE

NOTE: MOUNTING BRACKETS MUST BE
ATTACHED TO ARROW BOARD BEFORE
DUST COVER IS REPLACED

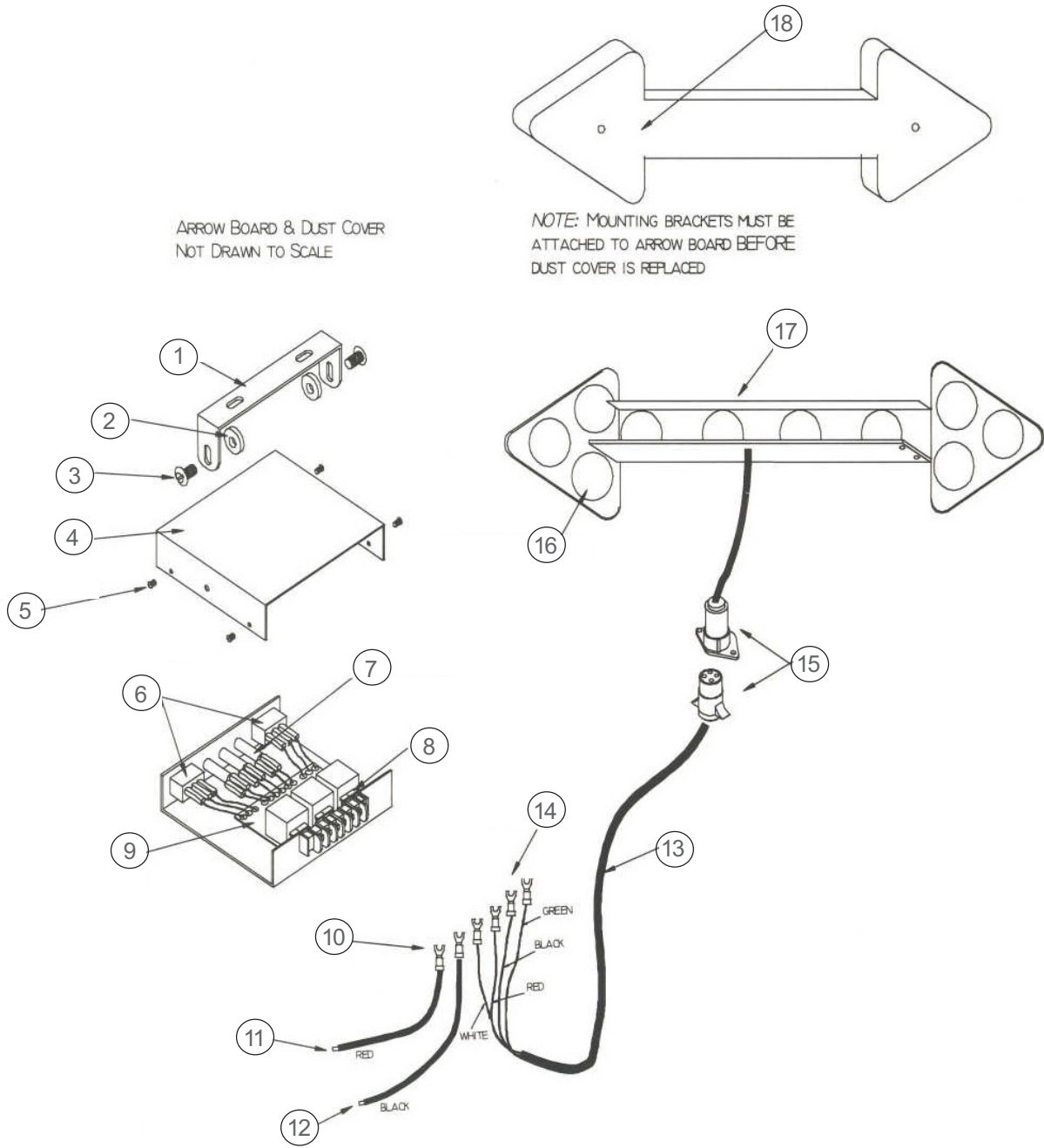

111110-E

VACASSY947

Arrow Board Option

| ITEM | QTY | PART # | DESCRIPTION |
|------|-----|------------|-------------------------|
| 1 | 1 | 8042197-1 | MOUNTING BAIL |
| 2 | 2 | 8042197-2 | WASHER |
| 3 | 2 | 8042197-3 | BOLT |
| 4 | 1 | 8042197-4 | COVER |
| 5 | 4 | 8042197-5 | MACHINE SCREW |
| 6 | 2 | 8042197-6 | SPDT SWITCH |
| 7 | 3 | 8042197-7 | RED PILOT LAMP |
| 8 | 1 | 8042197-8 | 15 AMP FUSE |
| 9 | 1 | 8042197-9 | CIRCUIT BOARD ASSY |
| 10 | 2 | 8042197-10 | #6 BLUE SPADE CONNECTOR |
| 11 | 4' | 8042197-11 | RED |
| 12 | 4' | 8042197-12 | BLACK |
| 13 | 20' | 8042197-13 | CABLE HARNESS |
| 14 | 4 | 8042197-14 | #6 BLUE SPADE CONNECTOR |
| 15 | 1 | 8042197-15 | 4-WAY CONNECTOR |
| 16 | 1 | 8042197-16 | STANDARD LAMP ASSY |
| 17 | 1 | 8042197-17 | ARROWBOARD FRAME |
| 18 | 1 | 8042197-18 | DUST COVER |
| * | 1 | 8045830 | ARROWBOARD BRACKET |
| * | 1 | 8046526 | ARROWBOARD MOUNT PLATE |

111110-E

VACASSY947

Aux.Hydraulics (Boom)

67HP/99HP

| ITEM | QTY | PART | DESCRIPTION |
|------|-----|------------|--|
| 1 | 1 | T401290 | ELBOW, 90 5/8"MP - 3/8"MJ |
| 2 | 1 | 8047333 | PUMP, HYD. BOOM 67/99 HP |
| 3 | 1 | 8043964 | ELBOW, 45 16HB - 12MB |
| 4 | 1 | 8047786 | HOSE VAC SUCTION 1" - 52"LG; PUMP TO SUCTION STRAINER |
| 5 | 1 | 8043963 | UNION, 1"MP - 1"BARB |
| 6 | 1 | 8011058 | SUCTION STRAINER 1" / 15GPM |
| 7 | 1 | T400240 | REDUCER, 1"MB - 1/2"MJ |
| 8 | 1 | 8047456 | FILTER, HYD. OIL AUX. HYD. |
| | 1 | 8047456-1 | PRESSURE INDICATOR |
| 9 | 1 | 8047330-14 | CAP, HYD. TANK |
| 10 | 1 | 8041829 | VALVE RELIEF |
| 11 | 5 | T400040 | UNION, 1/2"MP - 1/2"MJ |
| 12 | 1 | 8030498 | ELBOW, 3/8"MP - 3/8"MJ, 90 |
| 13 | 1 | 8042924 | HOSE ASSY VAC 6-60" ST-ST; PUMP TO PRIORITY VALVE |
| 14 | 1 | 8042006 | HOSE ASSY VAC 6-28" ST-90; 2GPM PRIORITY TO MANIFOLD |
| 15 | 1 | 3000084 | VALVE, PRIORITY 2.0 GPM |
| 16 | 1 | T401120 | ELBOW, 90 3/8MP - 1/2"MJ |
| 17 | 1 | T401125 | REDUCER, 3/8"MP - 1/2"FJ |
| 18 | 1 | T402040 | TEE, 1/2"MJ - 1/2"MJ - 1/2"MJ |
| 19 | 4 | T400814 | UNION, 1/2"MP - 1/2"FJ |
| 20 | 1 | T401250 | ELBOW, 90 3/8"MB - 3/8"MJ |
| 21 | 1 | T402148 | TEE, 6MB - 6MJ - 6MJ |
| 22 | 1 | T405200 | CAP, 1/4" FEM. JIC., HEX HEAD |
| 23 | 1 | T401230 | ELBOW, 90 1/4"MB - 1/4"MJ |
| 24 | 1 | T405064 | PLUG, 3/8"NPT |
| 25 | 1 | 8047787 | HOSE ASSY VAC 4-133" ST-90; TO TEE(DOOR CYL. BASE END) |
| 26 | 1 | 8047787 | HOSE ASSY VAC 4-133" ST-90; TO TEE (DOOR CYL. ROD END) |
| 27 | 1 | 8047788 | HOSE ASSY VAC 6-200" ST-ST; HOSE TO BOOM |
| 28 | 1 | 8043782 | HOSE ASSY VAC 6-77" ST-90; TO TEE (TANK CYL. BASE END) |
| 29 | 1 | 8043782 | HOSE ASSY VAC 6-77" ST-90; TO TEE (TANK CYL. ROD END) |
| 30 | 2 | T405203 | CAP, 3/8" FEM. JIC, HEX HEAD |
| 31 | 4 | T400037 | UNION, 6MB - 6MJ |
| 32 | 2 | T400550 | REDUCER, 3/8"MB - 1/4"MJ |
| 33 | 1 | 8043847 | HOSE ASSY VAC 6-34" ST-90; PRESSURE RELIEF DRAIN LINE |
| 34 | 7 | T402155 | TEE, 1/2"FJ - 1/2"MJ - 1/2"MJ |
| 35 | 1 | 8047388 | TANK, HYD. AUX. (CROSS2) |
| 36 | 1 | 8047330-02 | BASE MANIFOLD |
| 37 | 1 | 8047330-15 | CLEANOUT COVER |
| 38 | 1 | 8048117 | HOSE ASSY VAC 8-48" ST-90; COOLER TO FAN RETURN LINE |
| 39 | 2 | T401320 | ELBOW, 90 3/4"MB(ADJ) - 1/2"MJ |
| 40 | 1 | 8047920 | SWITCH, TEMP. 165DEG F |
| 41 | 1 | 8041492 | HOSE ASSY VAC 8-18" ST-90; PRESSURE SPIKE BYPASS LINE |
| 42 | 2 | T000312 | VALVE, CHECK 1/2"NPT |
| 43 | 1 | T400814 | UNION, 1/2"MP - 1/2"FJ |
| 44 | 1 | 8047321 | VALVE, CARTRIDGE CHECK 65PSI |
| | 1 | 8047322 | VALVE, BODY ALUM. |
| 45 | 1 | 8046706 | HOSE ASST VAC 8-126" ST-90; AUX. RETURN LINE |
| 46 | 1 | 8041869 | HOSE ASSY VAC 8-100" ST-90; AUX. PRESSURE RETURN LINE |
| 47 | 2 | T400705 | REDUCER, 8FJ - 6MJ |

052412-E

VACASSY993

Aux.Hydraulics (Boom)

67HP/99HP

| ITEM | QTY | PART | DESCRIPTION |
|------|-----|---------|---|
| 48 | 1 | 8031126 | REDUCER, 1/4"FP - 3/8"MJ |
| 49 | 1 | HM00092 | GAUGE, PRESSURE 3000PSI |
| 50 | 1 | 8043846 | HOSE ASSY VAC 6-10" ST-90; HOSE TO GAUGE |
| 51 | 2 | 8044647 | HOSE ASSY VAC 8-14" ST-ST; BALL VALVE TO PRESSURE/RETURN LINE |
| 52 | 1 | 8041149 | AUX. HYD. CONSOLE, MTG PLATE |
| 53 | 1 | 8031197 | BALL VALVE, 1/2"NPT |
| 54 | 1 | 8030662 | FITTING, QUICK DISCONNECT MALE |
| 55 | 1 | 8030663 | FITTING, QUICK DISCONNECT FEMALE |
| 56 | 1 | 8048118 | HOSE ASSY VAC 8-36" ST-90; MANIFOLD TO COOLER RETURN LINE |
| 57 | 1 | T405064 | PLUG, 3/8"NPT |

052412-E

VACASSY993

Vacuum Diesel Engine Schematic

VACUUM DIESEL ENGINE SCHEMATIC

080108

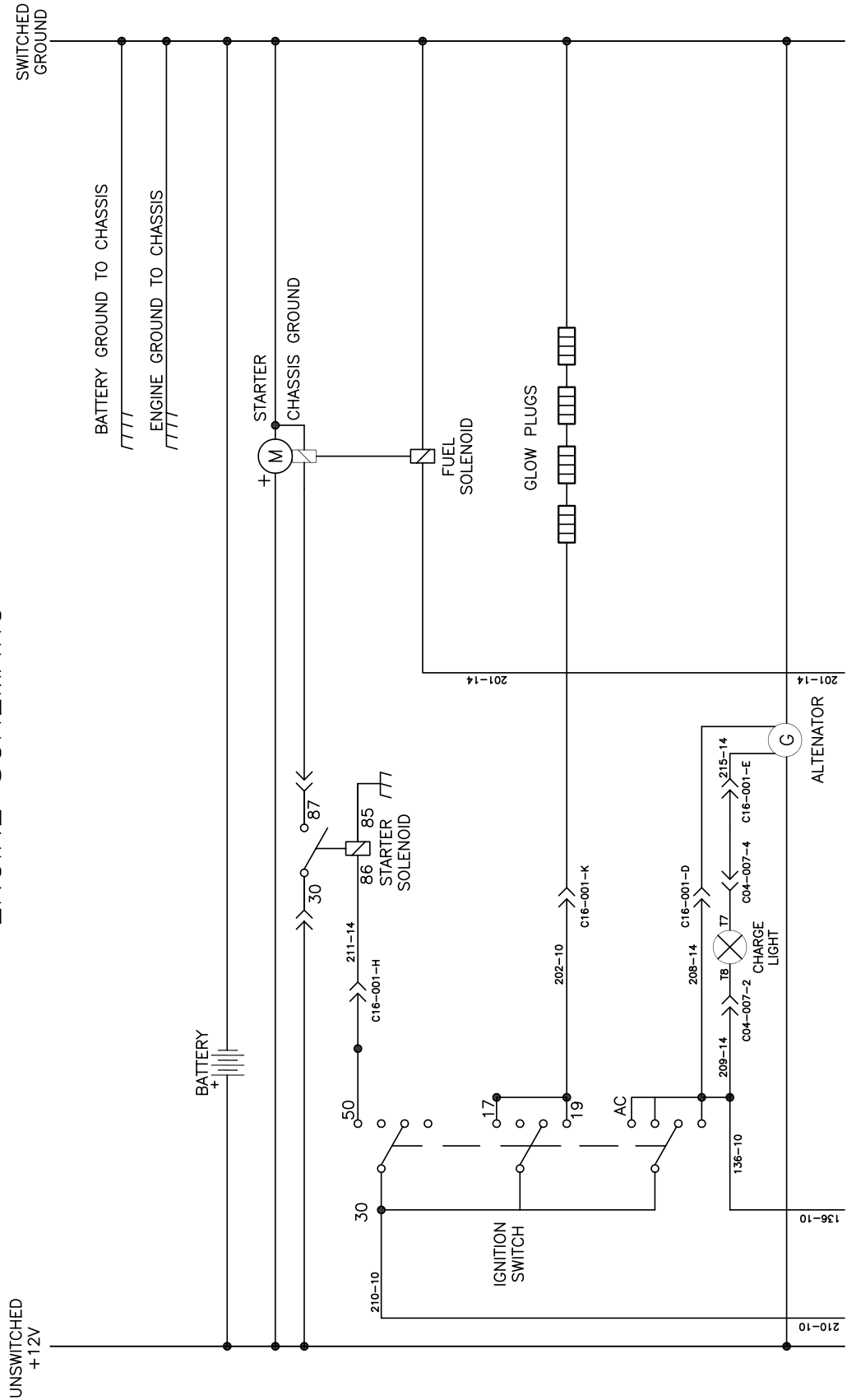

Vacuum Diesel Engine Schematic

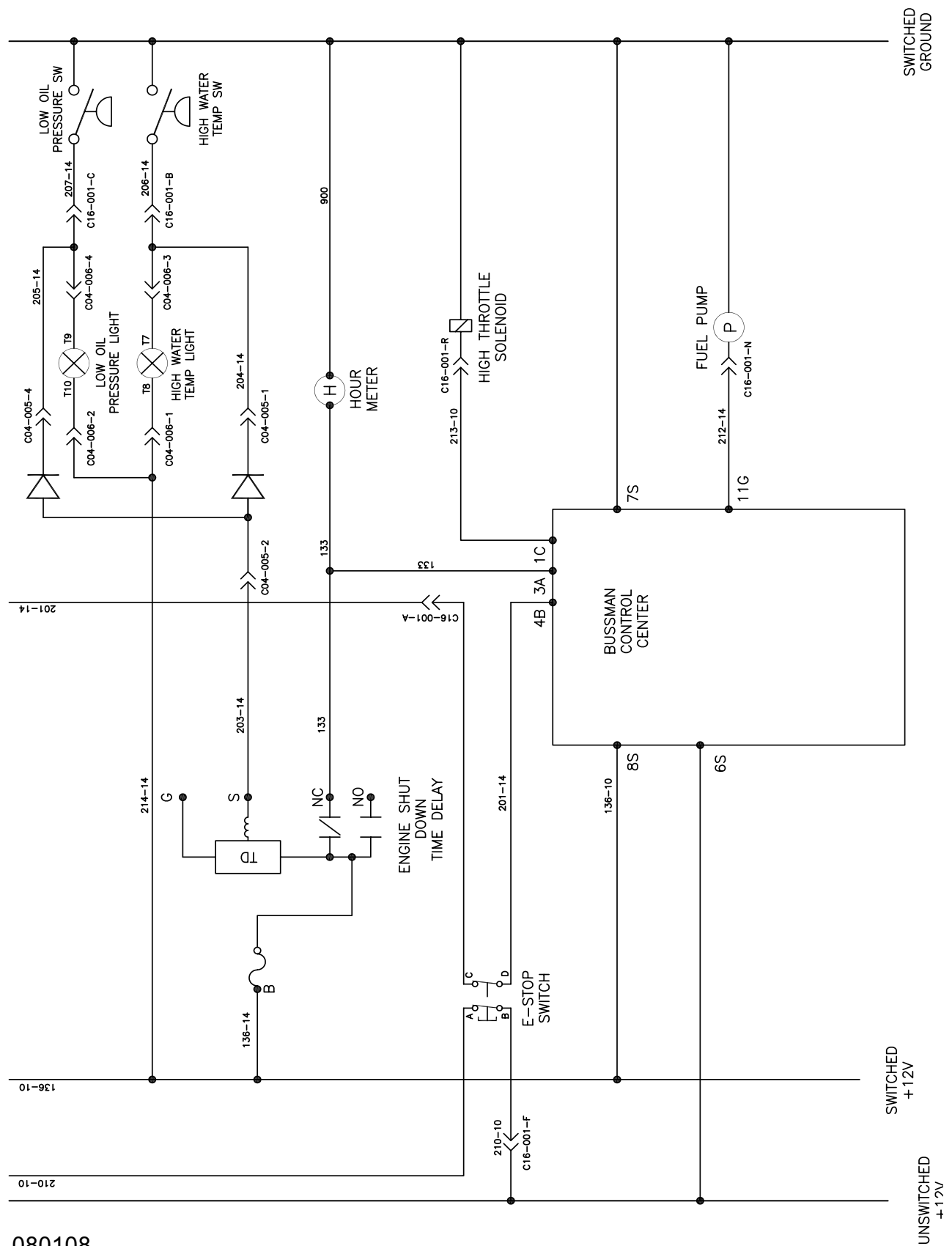

080108

Vacuum Diesel Engine Schematic

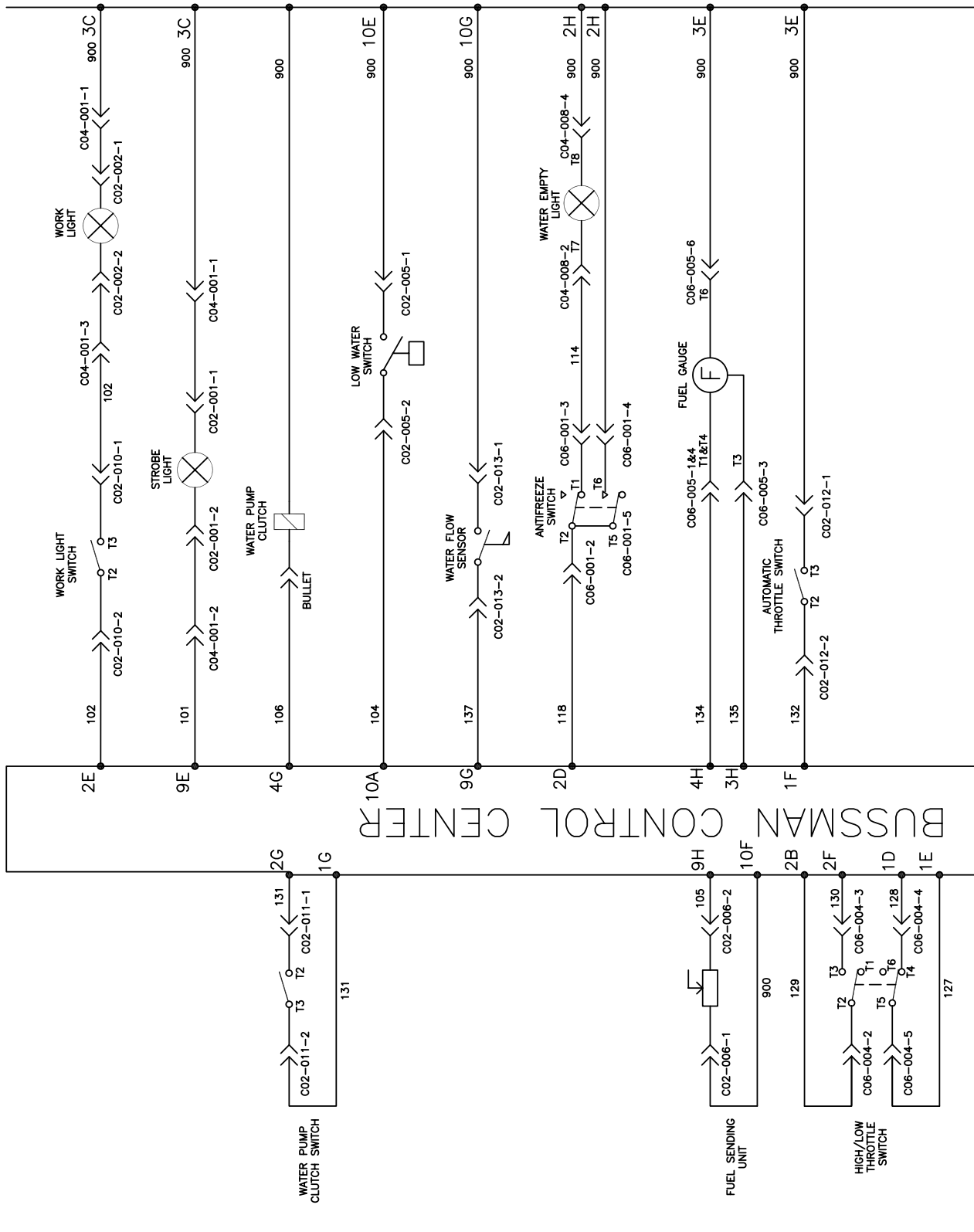

BUSSMAN CONTROL CENTER

Vacuum Diesel Engine Schematic

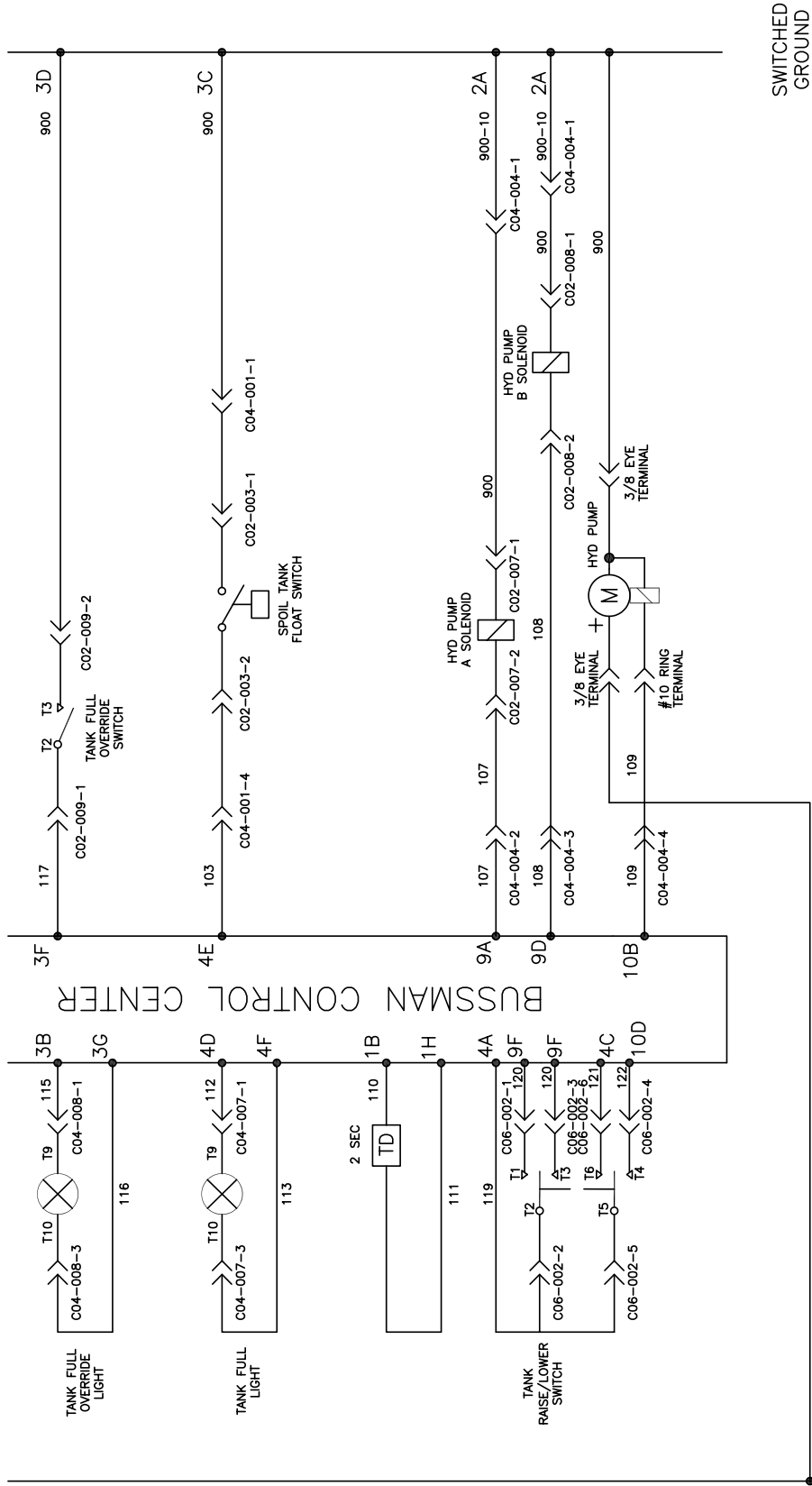

080108

PAGE LEFT BLANK

PAGE LEFT BLANK

Arrow Board Option

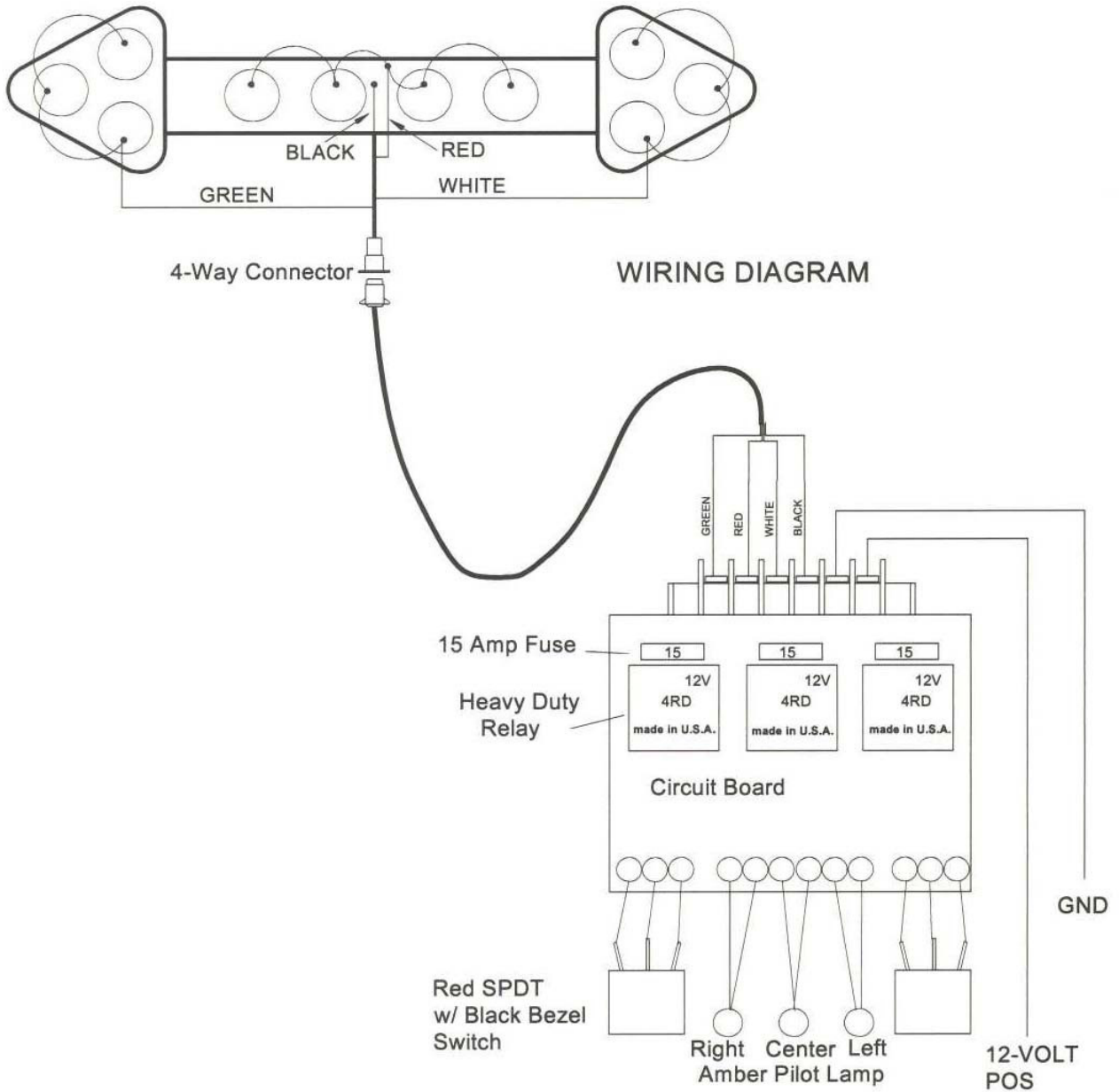

073008

VACASSY947

PAGE LEFT BLANK

MCLAUGHLIN – HOT BOX WIRING SCHEMATIC

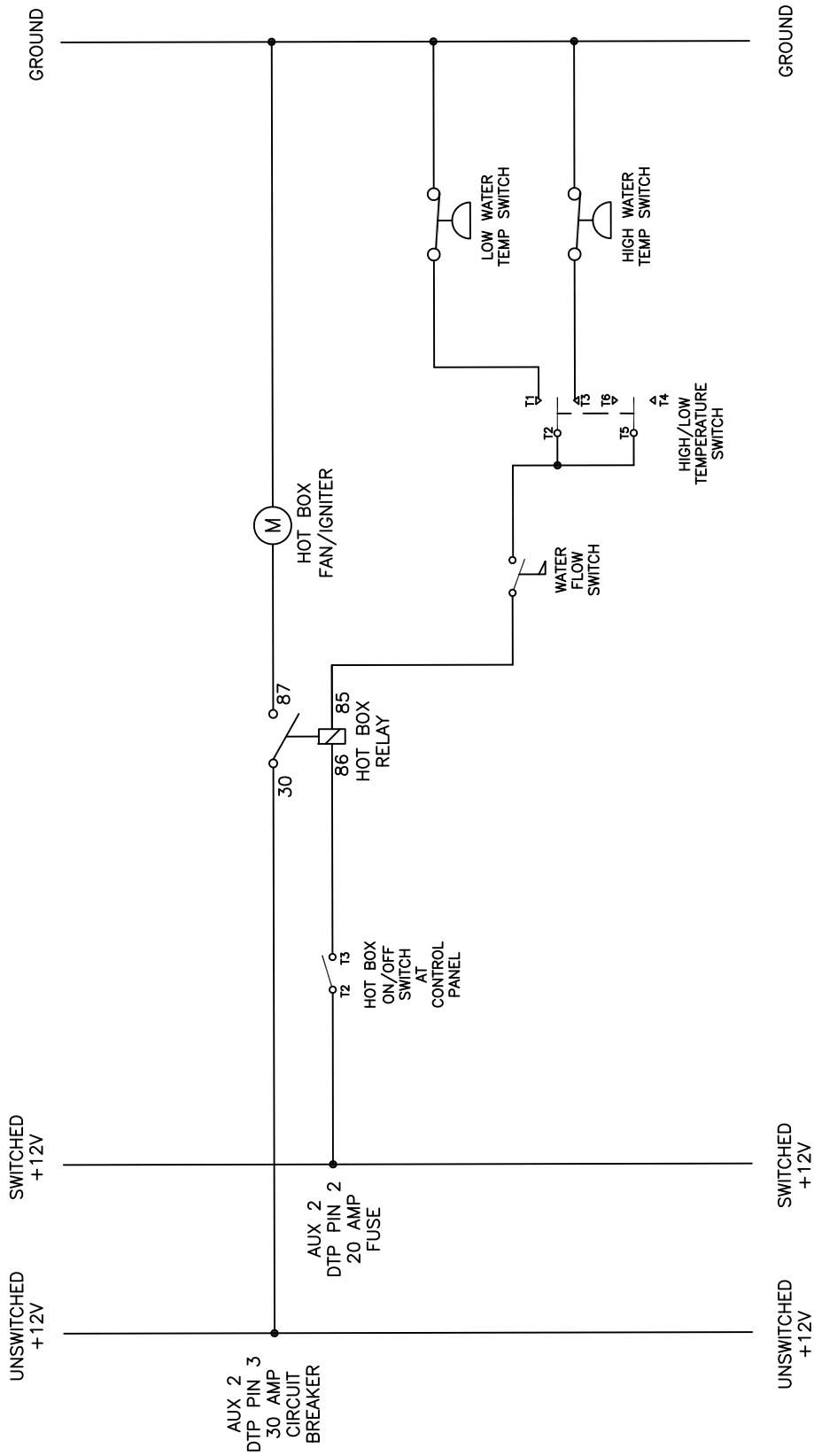

PAGE LEFT BLANK

MCLAUGHLIN – JETTER WIRING SCHEMATIC

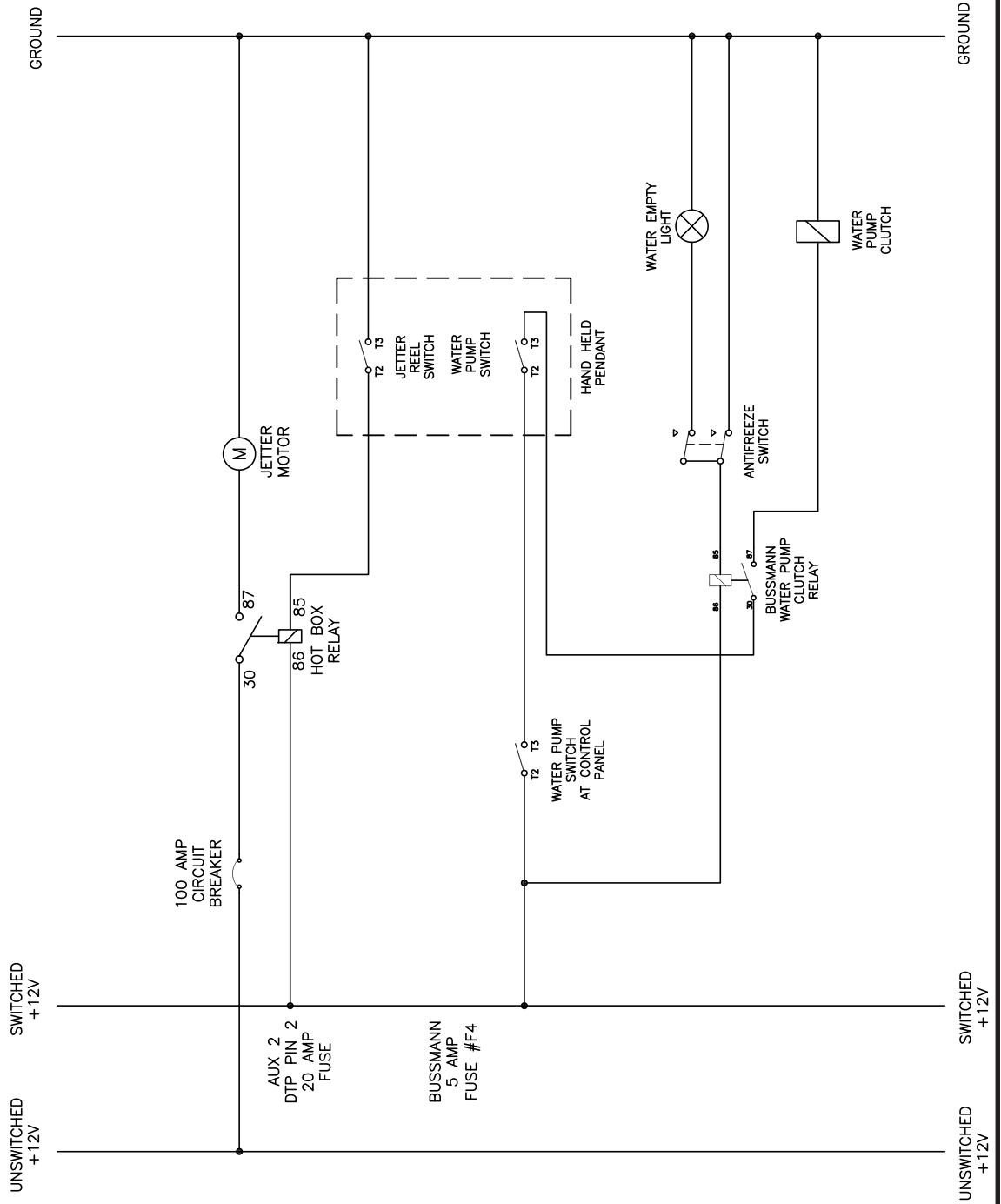

PAGE LEFT BLANK

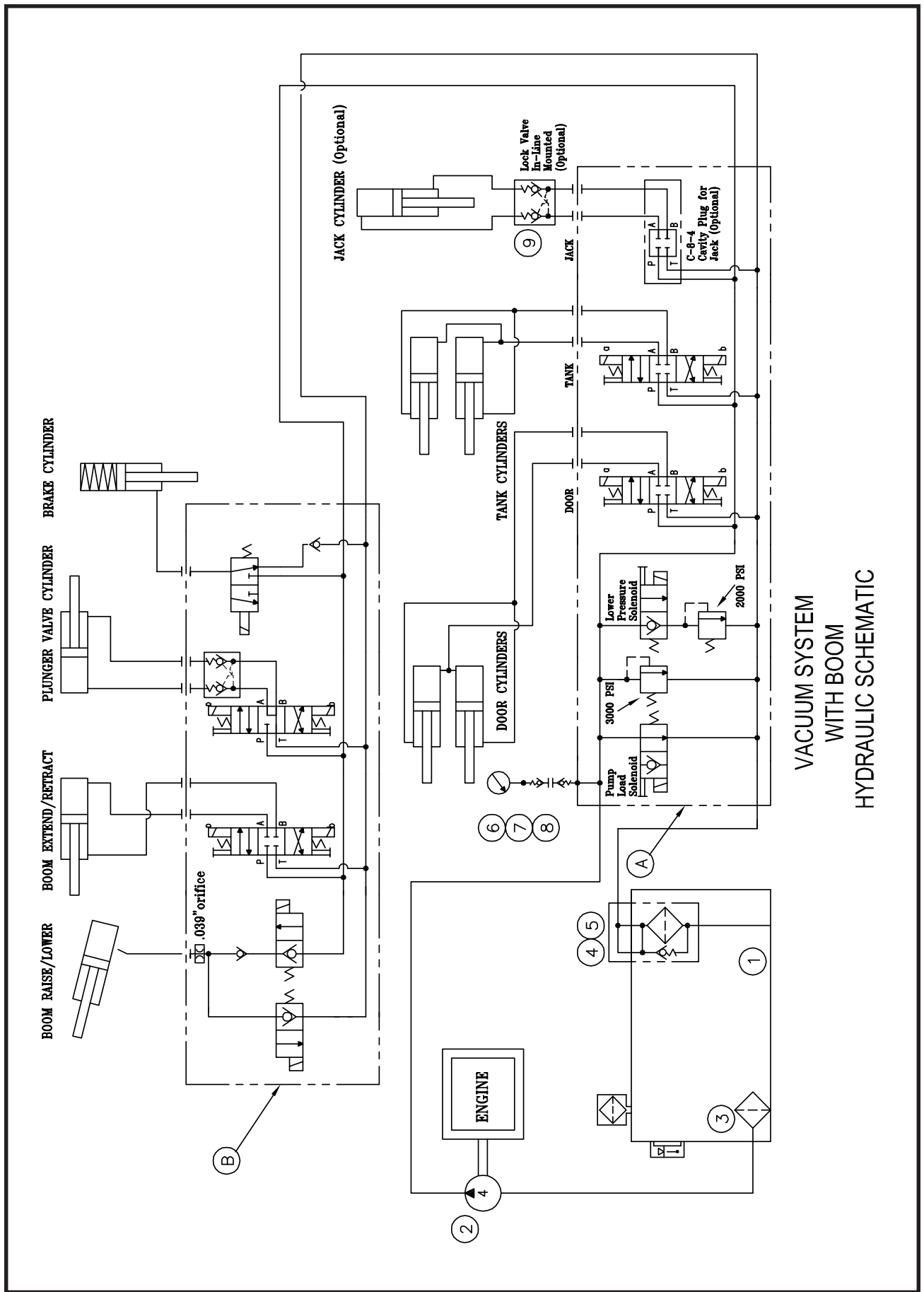

VACUUM SYSTEM WITH BOOM HYDRAULIC SCHEMATIC

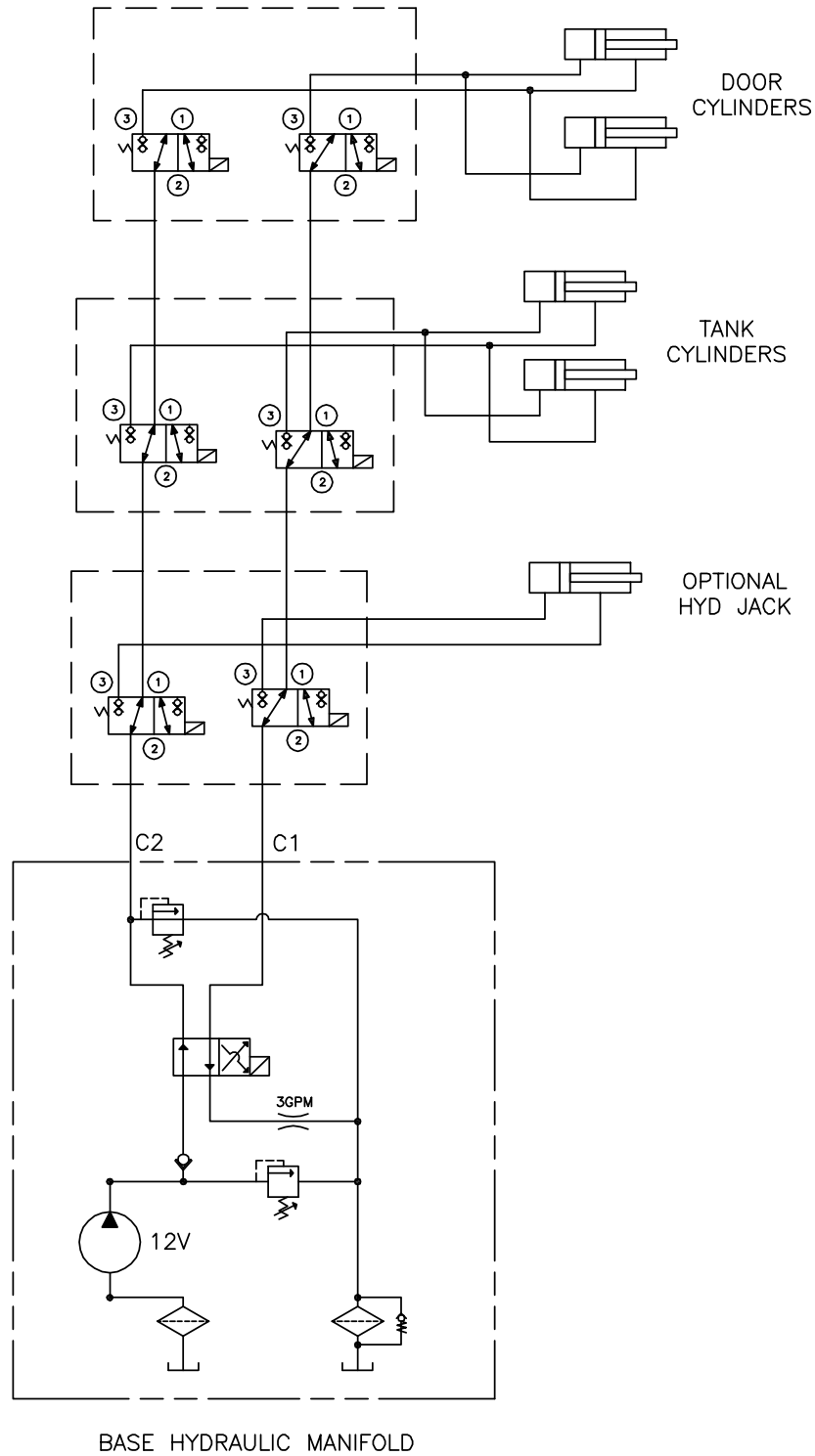

VACUUM SYSTEM
 W/O BOOM
 12V HYDRAULIC SCHEMATIC

PAGE LEFT BLANK

ROOTS

Blowers Compressors Exhausters

Universal URAI-DSL

Contents

| | |
|-----------------------|--------------------------|
| Information Summary | Troubleshooting |
| Safety Precautions | Inspection & Maintenance |
| Operating Limitations | Data |
| Lubrication | Assembly Drawings |
| Operation | Parts List |

Do These Things To Get The Most From Your ROOTS™ blower

- **Make sure both driving and driven equipment is correctly lubricated before start-up. See LUBRICATION.**
- In event of trouble during installation or operation, do not attempt repairs of ROOTS furnished equipment. Notify ROOTS, giving all nameplate information plus an outline of operating conditions and a description of the trouble. Unauthorized attempts at equipment repair may void ROOTS warranty.
- Units out of warranty may be repaired or adjusted by the owner. Good inspection and maintenance practices should reduce the needs for repairs.

NOTE: Information in this manual is correct as of the date of publication. ROOTS reserves the right to make design or material changes without notice, and without obligation to make similar changes without notice, and without obligation to make similar changes on equipment of prior manufacture.



Safety Precautions

It is important that all personnel observe safety precautions to minimize the chances of injury. Among many considerations, the following should be particularly noted:

- Blower casing and associated piping or accessories may become hot enough to cause major skin burns on contact.
- Internal and external rotating parts of the blower and driving equipment can produce serious physical injuries. Do not reach into any opening in the blower while it is operating, or while subject to accidental starting. Protect external moving parts with adequate guards.
- Disconnect power before doing any work, and avoid bypassing or rendering inoperative any safety or protective devices.
- If blower is operated with piping disconnected, place a strong coarse screen over the inlet and avoid standing in the discharge air stream. **CAUTION: Never cover the blower inlet with your hand or other part of body.**
- Stay clear of the blast from pressure relief valves and the suction area of vacuum relief valves.
- Use proper care and good procedures in handling, lifting, installing, operating and maintaining the equipment.
- Casing pressure must not exceed 25 PSI (1725 mbar) gauge. Do not pressurize vented cavities from an external source, nor restrict the vents without first consulting Roots.
- Do not use air blowers on explosive or hazardous gases.
- Other potential hazards to safety may also be associated with operation of this equipment. All personnel working in or passing through the area should be trained to exercise adequate general safety precautions.

Operating Limitations

A ROOTS blower or exhauster must be operated within certain approved limiting conditions to enable continued satisfactory performance. Warranty is contingent on such operation.

Maximum limits for pressure, temperature and speed are specified in TABLE 1 for various models & sizes of blowers & exhausters. These limits apply to all units of normal construction, when operated under standard atmospheric conditions. Be sure to arrange connections or taps for instruments, thermometers and pressure or vacuum gauges at or near the inlet and discharge connections of the unit. These, along with a tachometer, will enable periodic checks of operating conditions.

PRESSURE – The pressure rise, between inlet and discharge, must not exceed the figure listed for the specific unit frame size concerned. Also, in any system where the unit inlet is at a positive pressure above atmosphere a maximum case rating of 25 PSI gauge (1725 mbar) should not be exceeded without first consulting Roots. Never should the maximum allowable differential pressure be exceeded.

On vacuum service, with the discharge to atmospheric pressure, the inlet suction or vacuum must not be greater than values listed for the specific frame size.

TEMPERATURE – Blower & exhauster frame sizes are approved only for installations where the following temperature limitations can be maintained in service:

- Measured temperature rise must not exceed listed values when the inlet is at ambient temperature. Ambient is considered as the general temperature of the space around the unit. This is not outdoor temperature unless the unit is installed outdoors.
- If inlet temperature is higher than ambient, the listed allowable temperature rise values must be reduced by 2/3 of the difference between the actual measured inlet temperature and the ambient temperature.
- The average of the inlet and discharge temperature must not exceed 250°F. (121°C).
- The ambient temperature of the space the blower/motor is installed in should not be higher than 120°F (48.8°C).

SPEED – These blowers & exhausters may be operated at speeds up to the maximum listed for the various frame sizes. They may be direct coupled to suitable constant speed drivers if pressure/temperature conditions are also within limits. At low speeds, excessive temperature rise may be a limiting factor.

Special Note: The listed maximum allowable temperature rise for any particular blower & exhauster may occur well before its maximum pressure or vacuum rating is reached. This may occur at high altitude, low vacuum or at very low speed. The units' operating limit is always determined by the maximum rating reached first. It can be any one of the three: Pressure, Temperature or Speed.

Lubrication

For Units with Splash Lubrication on Both Ends

Bearings and oil seals are lubricated by the action of the timing gears or oil slingers which dip into the main oil sumps

causing oil to splash directly on gears and into bearings and seals. A drain port is provided below each bearing to prevent an excessive amount of oil in the bearings. Seals located inboard of the bearings in each headplate effectively retain oil within the sumps. Any small leakage that may occur should the seals wear passes into a cavity in each vented headplate and is drained downward.

Oil sumps on each end of the blower are filled by removing top vent plugs, Item (25), and filling until oil reaches the middle of the oil level sight gauge when the unit is not operating, Item (45 or 53), DO NOT FILL PAST THE MIDDLE OF THE SIGHT GLASS.

Initial filling of the sumps should be accomplished with the blower not operating, in order to obtain the correct oil level. Approximate oil quantities required for blowers of the various models and configurations are listed in Table 3. Use a good grade of industrial type non-detergent, rust inhibiting, anti-foaming oil and of correct viscosity per Table 2. ***ROOTS synthetic oil (Roots P/N 813-106-) is specified and recommended.** Roots does not recommend automotive type lubricants, as they are not formulated with the properties mentioned above.

The oil level may rise or fall on the gauge during operation, to an extent depending somewhat on oil temperature and blower speed.

Proper lubrication is usually the most important single consideration in obtaining maximum service life and satisfactory operation from the unit. Unless operating conditions are quite severe, a weekly check of oil level and necessary addition of lubricant should be sufficient. During the first week of operation, check the oil levels in the oil sumps about once a day, and watch for leaks. Replenish as necessary. Thereafter, an occasional check should be sufficient. It is recommended that the oil be changed after initial 100 hours of operation. Frequent oil changing is not necessary unless the blower is operated in a very dusty location.

Normal life expectancy of petroleum based oils is about 2000 hours with an oil temperature of about 180°F (82°C). As the oil temperature increases by increments of 15-18°F (8°C - 10°C), the life is reduced by half. Example: Oil temperatures of 210-216°F (99°C - 102°C) will produce life expectancy of 1/4 or 500 hours. Therefore, it is considered normal to have oil change periods of 500 hours with petroleum based oils.

Normal life expectancy of ROOTS™ Synthetic Oil is about 4000 to 8000 hours with an oil temperature of about 180°F (82°C). As the oil temperature increases by increments of 15-18°F (8°C - 10°C), the life is reduced by half. Example: Oil temperatures of 210-216°F (99°C - 102°C) will produce life expectancy of 1/4 or 1000 to 2000 hours.

NOTE: To estimate oil temperature, multiply the discharge temperature of the blower by 0.80. Example: if the discharge air temperature of the blower is 200° F, it is estimated that the oil temperature is 160° F.

*ROOTS™ Synthetic Oil & Grease is superior in performance to petroleum based products. It has high oxidation stability, excellent corrosion protection, extremely high film strength and low coefficient of friction. Typical oil change intervals are increased 2-3 times over petroleum based lubricants. Also, ROOTS™ Synthetic Oil is 100% compatible with petroleum based oils. Simply drain the oil in the blower and refill the reservoirs with ROOTS™ Synthetic Oil to maintain optimum performance of your ROOTS™ blower.

Operation

Before operating a blower under power for the first time, recheck the unit and the installation thoroughly to reduce the likelihood of avoidable troubles. Use the following procedure check list as a guide, but consider any other special conditions in the installation.

- Be certain that no bolts, tools, rags, or debris have been left in the blower air chamber or piping.
- If an outdoor intake without filter is used, be sure the opening is located so it cannot pick up dirt and is protected by a strong screen or grille. Use of the temporary protective screen as described under INSTALLATION is strongly recommended.
- Recheck blower leveling, drive alignment and tightness of all mounting bolts if installation is not recent. If belt drive is used, adjust belt tension correctly.
- Turn drive shaft by hand to make sure impellers still rotate without bumping or rubbing at any point.
- Ensure oil levels in the main oil sumps are correct.
- Check lubrication of driver. If it is an electric motor, be sure that power is available and that electrical overload devices are installed and workable.
- Open the manual unloading valve in the discharge air line. If a valve is in the inlet piping, be sure it is open.
- Bump blower a few revolutions with driver to check that direction of rotation agrees with arrow near blower shaft, and that both coast freely to a stop.

After the preceding points are cleared, blower is ready for trial operation under "no-load" conditions. The following procedure is suggested to cover this initial operation test period.

- a. Start blower, let it accelerate to full speed, then shut off. Listen for knocking sounds, both with power on and as speed slows down.
- b. After blower comes to a complete stop, repeat above, but let blower run 2 or 3 minutes. Check for noises, such as knocking sounds.
- c. After blower comes to a complete stop, operate blower for about 10 minutes unloaded. Check oil levels. Observe cylinder and headplate surfaces for development of hot spots such as burned paint, indicating impeller rubs. Be aware of any noticeable increase in vibration.

Assuming that all trials have been satisfactory, or that necessary corrections have been made, the blower should now have a final check run of at least one hour under normal operating conditions. After blower is restarted, gradually

close the discharge unloading valve to apply working pressure. At this point it is recommended that a pressure gauge or manometer be connected into the discharge line if not already provided, and that thermometers be in both inlet and discharge lines. Readings from these instruments will show whether pressure or temperature ratings of the blower are being exceeded.

During the final run, check operating conditions frequently and observe the oil levels at reasonable intervals. If excessive noise or local heating develops, shut down immediately and determine the cause. If either pressure rise or temperature rise across the blower exceeds the limit specified in this manual, shut down and investigate conditions in the piping system. Refer to the TROUBLESHOOTING CHECKLIST for suggestions on various problems that may appear.

The blower should now be ready for continuous duty operation at full load. During the first few days make periodic checks to determine whether all conditions remain steady, or at least acceptable. This may be particularly important if the blower is supplying air to a process system where conditions can vary. At the first opportunity, stop the blower and clean the temporary inlet protective screen. If no appreciable amount of debris has collected, the screen may be removed. See comments under INSTALLATION. At this same time, verify leveling, coupling alignment or belt tension, and mounting bolt tightness.

Should operating experience prove that blower capacity is a little too high for the actual air requirements, a small excess may be blown off continuously through the manual unloading or vent valve. Never rely on the pressure relief valve as an automatic vent. Such use may cause the discharge pressure to become excessive, and can also result in failure of the valve itself. If blower capacity appears to be too low, refer to the TROUBLESHOOTING CHECKLIST.

Vibration Assessment Criteria

With measurements taken at the bearing locations on the housings, see chart below for an appropriate assessment guide for rotary lobe blowers rigidly mounted on stiff foundations.

In general, blower vibration levels should be monitored on a regular basis and the vibration trend observed for progressive or sudden change in level. If such a change occurs, the cause should be determined through spectral analysis.

As shown on the chart below, the level of all pass vibration will determine the need to measure discrete frequency vibration levels and the action required.

| All Pass Vibration (in/sec) | Discrete Frequency Vibration (in/sec) | Action |
|-----------------------------------|---------------------------------------|-------------|
| 0.45 or less | N/R | Acceptable |
| Greater than 0.45 but 1.0 or less | 0.45 or less @ any frequency | Acceptable |
| | Greater than 0.45 @ any frequency | Investigate |
| Greater than 1.0 | Less than 1.0 | Investigate |
| | Greater than 1.0 | Investigate |

Troubleshooting Checklist

| Trouble | Item | Possible Cause | Remedy |
|---|------|---|--|
| No flow | 1 | Speed too low | Check by tachometer and compare with published performance |
| | 2 | Wrong rotation | Compare actual rotation with Figure 1 Change driver if wrong |
| | 3 | Obstruction in piping | Check piping, valves, silencer to assure open flow path |
| Low capacity | 4 | Speed too low | See item 1, If belt drive, check for slippage and readjust tension |
| | 5 | Excessive pressure rise | Check inlet vacuum and discharge pressure and compare with Published performance |
| | 6 | Obstruction in piping | See item 3 |
| | 7 | Excessive slip | Check inside of casing for worn or eroded surfaces causing excessive clearances |
| Excessive power | 8 | Speed too high | Check speed and compare with published performance |
| | 9 | Excessive pressure rise | See Item 5 |
| | 10 | Impeller rubbing | Inspect outside of cylinder for high temperature areas, then check for impeller contact at these points. Correct blower mounting, drive alignment |
| | 11 | Scale, sludge, rust or product build up | Clean blower appropriately |
| Damage to bearings or gears | 12 | Inadequate lubrication | Check oil sump levels in gear and drive end headplates |
| | 13 | Excessive lubrication | Check oil levels. If correct, drain and refill with clean oil of recommended grade |
| | 14 | Excessive pressure rise | See Item 5 |
| | 15 | Coupling misalignment | Check carefully. Realign if questionable |
| | 16 | Excessive belt tension | Readjust for correct tension |
| Vibration | 17 | Misalignment | See Item 15 |
| | 18 | Impellers rubbing | See Item 10 |
| | 19 | Worn bearings/gears | Check gear backlash and condition of bearings, and replace as indicated |
| | 20 | Unbalanced or rubbing impeller | Scale or process material may build up on casing and impellers, or inside impellers. Remove build-up to restore original clearances and impeller balance |
| | 21 | Driver or blower loose | Tighten mounting bolts securely |
| | 22 | Piping resonances | Determine whether standing wave pressure pulsations are present in the piping |
| | 23 | Scale/sludge build-ups | Clean out interior of impeller lobes to restore dynamic balance |
| Driver stops, or will not start | 24 | Casing strain | Re-work piping alignment to remove excess strain |
| | 25 | Impeller stuck | Check for excessive hot spot on headplate or cylinder. See item 10. Look for defective shaft bearing and/or gear teeth |
| | 26 | Scale, sludge, rust or product build-up | Clean blower appropriately |
| Excessive breather | 27 | Broken seal | Replace seals |
| Blow-by or excessive oil leakage to vent area | 28 | Defective O-ring | Replace seals and O-ring |
| Excessive oil leakage in vent area | 29 | Defective/plugged breather | Replace breather and monitor oil leakage |
| | 30 | Oil level too high | Check sump levels in gear and drive headplates. |
| | 31 | Oil type or viscosity incorrect | Check oil to insure it meets recommendations. Drain then fill with clean oil of recommended grade. |
| | 32 | Blower running hot | Check blower operating conditions to ensure they are within the operating limitations defined in this manual. |

Inspection & Maintenance: Universal RAI® series blowers

A good program of consistent inspection and maintenance is the most reliable method of minimizing repairs to a blower. A simple record of services and dates will help keep this work on a regular schedule. Basic service needs are:

- Lubrication
- Checking for hot spots
- Checking for increases or changes in vibration and noise
- Recording of operating pressures and temperatures

Above all, a blower must be operated within its specified rating limits, to obtain satisfactory service life.

A newly installed blower should be checked often during the first month of full-time operation. Attention there after may be less frequent assuming satisfactory performance. Lubrication is normally the most important consideration and weekly checks of lubricant levels in the gearbox and bearing reservoirs should be customary. Complete oil change schedules are discussed under **LUBRICATION**.

Driver lubrication practices should be in accordance with the manufacturer's instructions. If direct connected to the blower through a lubricated type coupling, the coupling should be checked and greased each time blower oil is changed. This will help reduce wear and prevent unnecessary vibration. In a belted drive system, check belt tension periodically and inspect for frayed or cracked belts.

In a new, and properly installed, unit there is no contact between the two impellers, or between the impellers and cylinder or headplates. Wear is confined to the bearings (which support and locate the shafts) the oil seals, and the timing gears. All are lubricated and wear should be minimal if clean oil of the correct grade is always used. Seals are subject to deterioration as well as wear, and may require replacement at varying periods.

Shaft bearings are designed for optimum life under average conditions with proper lubrication and are critical to the service life of the blower. Gradual bearing wear may allow a shaft position to change slightly, until rubbing develops between impeller and casing. This will cause spot heating, which can be detected by observing these surfaces. Sudden bearing failure is usually more serious. Since the shaft and impeller are no longer supported and properly located, extensive general damage to the blower casing and gears is likely to occur.

Oil seals should be considered expendable items, to be replaced whenever drainage from the headplate vent cavity becomes excessive or when the blower is disassembled for

any reason. Some oil seal leakage may occur since an oil film under the lip is required for proper operation. Periodically leaked oil should be wiped off from surfaces. Minor seal leakage should not be considered as indicating seal replacement.

Timing gear wear, when correct lubrication is maintained, should be negligible. Gear teeth are cut to provide the correct amount of backlash, and gears correctly mounted on the shafts will accommodate a normal amount of tooth wear without permitting contact between lobes of the two impellers. However, too high an oil level will cause churning and excessive heating. This is indicated by unusually high temperature at the bottom of the gear housing. Consequent heating of the gears will result in loss of tooth-clearance, backlash and rapid wear of the gear teeth usually will develop. Continuation of this tooth wear will eventually produce impeller contacts (knocking), and from this point serious damage will be unavoidable if blower operation is continued. A similar situation can be produced suddenly by gear tooth fracture, which is usually brought on by sustained overloading or momentary shock loads.

Problems may also develop from causes other than internal parts failure. Operating clearances within a blower are only a few thousandths of an inch. This makes it possible for impeller interference or casing rubs to result from shifts in the blower mounting, or from changes in piping support. If this type of trouble is experienced, and the blower is found to be clean, try removing mounting strains. Loosen blower mounting bolts and reset the leveling and drive alignment. Then tighten mounting again, and make sure that all piping meets blower connections accurately and squarely. Foreign materials in the blower will also cause trouble, which can only be cured by disconnecting the piping and thoroughly cleaning the blower interior.

A wide range of causes & solutions for operating troubles are covered in the **TROUBLE SHOOTING CHECKLIST**. The remedies suggested should be performed by qualified mechanics with a good background. Major repairs generally are to be considered beyond the scope of maintenance, and should be referred to an authorized Roots distributor.

Warranty failures should not be repaired at all, unless specific approval has been obtained through Roots before starting work. Unauthorized disassembly within the warranty period may void the warranty.

Figure 2 - Allowable Overhung Loads for V-Belt Drives Universal RAI®/URAI®-DSL Units

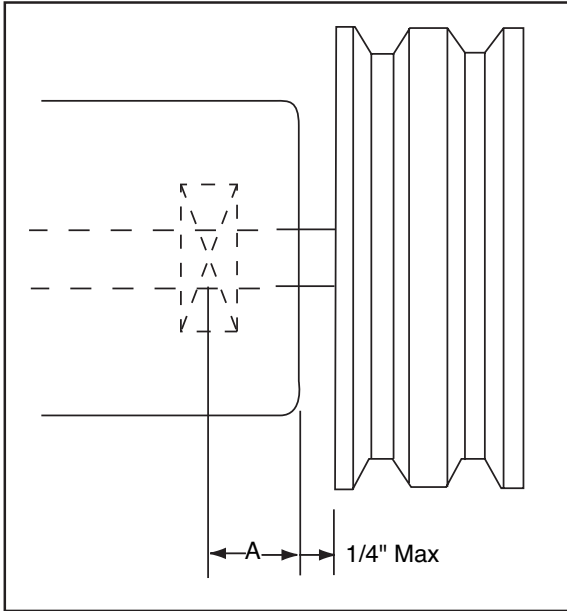

$$\text{Belt Pull lbs} = \frac{252100 \cdot \text{Motor HP}}{\text{Blower RPM} \cdot \text{Sheave Diameter}}$$

$$\text{Shaft Load (lb.in)} = \text{Belt Pull} \cdot \left(A + \frac{1}{4} + \frac{\text{Sheave Width}}{2} \right)$$

| Frame Size | Dimension "A" | Max Allowable Shaft Load (lb-in) | Min Sheave Diameter |
|------------|---------------|----------------------------------|---------------------|
| 59 | 1.13 | 1,325 | 6.00 |

NOTE:

Arc of sheave belt contact on the smaller sheave not to be less than 170°

Driver to be installed on the inlet side for vertical units, and on the drive shaft side for horizontal units.

Roots recommends the use of two or more 3V, 5V or 8V matched set or banded belts and sheaves.

Specified Lubricants

ROOTS Synthetic Oil: ISO-VG-320 Grade

| | Part Number |
|---------------|-------------|
| Quart | 13106004 |
| Gallon | 13106005 |
| Case (12 qts) | 13106007 |

ROOTS Synthetic Oil: ISO-VG-220 Grade

| | Part Number |
|---------------|-------------|
| Quart | 13106001 |
| Gallon | 13106002 |
| Case (12 qts) | 13106008 |

ROOTS Synthetic Oil: ISO-VG-150 Grade

| | Part Number |
|----------------|-------------|
| Quart | 13106020 |
| Gallon | 13106021 |
| Case (12 qts) | 13106023 |
| 5 Gallon Pail | 13106022 |
| 55 Gallon Drum | 13106025 |

Drive End Breather Orientation for URA-DSL blowers with Oil Lube

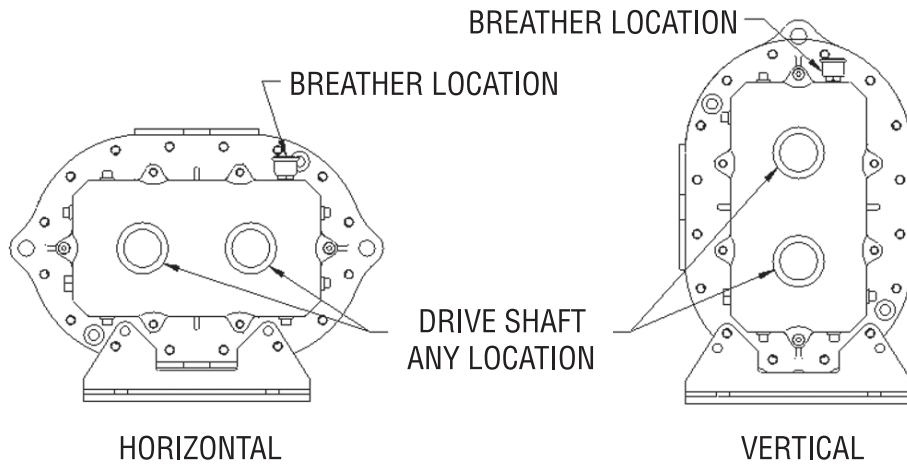

URAI DSL BREATHER ORIENTATION

Table 1 - URAI, URAI-DSL Blowers,
Maximum Allowable Operating Conditions

| Frame Size | Gear Diameter (Inch) | Speed RPM | Temp. Rise Deg F (Deg C) | Delta Pressure PSI (mbar) | Inlet Vacuum INHG (mbar) |
|------------|----------------------|-----------|--------------------------|---------------------------|--------------------------|
| 59 | 5 | 2,850 | 225 (125) | 7 (483) | 15 (500) |

Table 2 - Recommended Oil Grades

| Ambient Temperature °F (°C) | ISO Viscosity No. |
|-----------------------------|-------------------|
| Above 90° (32°) | 320 |
| 32° to 90° (0° to 32°) | 220 |
| 0° to 32° (-18° to 0°) | 150 |
| Below 0° (-18°) | 100 |

Ambient temperature is defined as the temperature of the space in which the blower and drive are located.

Table 3 - Approximate Oil Sump Capacities

These capacities are provided to assist in stocking the correct amount of oil. Exact sump capacities may differ slightly. See "Lubrication" section for proper filling instructions.

URAI-DSL Splash Lubricated Blowers

| Frame Size | Gear End Capacity Fl. Oz (Liters) | Drive End Capacity Fl. Oz. (Liters) |
|------------|-----------------------------------|-------------------------------------|
| 59 | 27.6 (.82) | 14.8 (.44) |

Basic Connection & Drive Shaft Information

URAI DSL AIR BLOWERS (with Dual Splash Lubrication DSL)

| BOM# | FRAME SIZE | INLET/DISCHARGE CONN. | SHAFT DIAMETER | BARE WEIGHT |
|-----------|------------|-----------------------|----------------|-------------|
| T30361020 | 59 | 4" NPT | 1.125 | 209 |

Universal RAI air blowers include detachable mounting feet which permit vertical or horizontal installation. The units are center timed for rotation in either direction. The bearings on the URAI are grease lubricated on the drive end and splash lubricated on the gear end. The URAI-DSL is splash lubricated on BOTH ends.

PAGE LEFT BLANK



US \$3.00, Canada \$4.50

RAM™ AND RCS (400 & 600 VERTICAL) SERIES

CONTENTS

| | | | |
|-------------------------------------|---|------------------------------------|---------|
| INFORMATION SUMMARY | 1 | TROUBLESHOOTING | 9 |
| SAFETY PRECAUTIONS | 2 | INSPECTION & MAINTENANCE | 10 |
| OPERATING LIMITATIONS | 2 | FIGURES | 8,11-13 |
| INSTALLATION | 3 | TABLES | 14 |
| LUBRICATION | 6 | PARTS LIST | 15 |
| OPERATION | 7 | ASSEMBLY DRAWINGS | 16 |
| OPERATING CHARACTERISTICS | 8 | | |

DO THESE THINGS TO GET THE MOST FROM YOUR ROOTS™ BLOWER

- Check shipment for damage. If found, file claim with carrier and notify ROOTS.
- Unpack shipment carefully, and check contents against Packing List. Notify ROOTS if a shortage appears.
- Store in a clean, dry location until ready for installation. Lift by methods discussed under INSTALLATION to avoid straining or distorting the equipment. Keep covers on all openings. Protect against weather and corrosion if outdoor storage is necessary.
- Read OPERATING LIMITATIONS and INSTALLATION sections in this manual and plan the complete installation.
- Provide for adequate safeguards against accidents to persons working on or near the equipment during both installation and operation. See SAFETY PRECAUTIONS.
- Install all equipment correctly. Foundation design must be adequate and piping carefully done. Use recommended accessories for operating protection.
- Make sure both driving and driven equipment is correctly lubricated before start-up. See LUBRICATION.

- In event of trouble during installation or operation, do not attempt repairs of ROOTS furnished equipment. Notify ROOTS, giving all nameplate information plus an outline of operating conditions and a description of the trouble. Unauthorized attempts at equipment repair may void ROOTS warranty.
- Units out of warranty may be repaired or adjusted by the owner. Good inspection and maintenance practices should reduce the need for repairs.

NOTE: Information in this manual is correct as of the date of publication. ROOTS reserves the right to make design or material changes without notice, and without obligation to make similar changes on equipment of prior manufacture.

For your nearest ROOTS Office, dial our Customer Service Hot Line toll free; 1 877 363 ROOT(S) (7668) or direct 281-966-4700.



ROOTS™ products are sold subject to the current General terms of Sale, GTS-5001 and Warranty Policy WP-5020. Copies are available upon request. Contact your local ROOTS Office or ROOTS Customer Service Hot Line 1.877.363.ROOT(S) (7668).

SAFETY PRECAUTIONS

It is important that all personnel observe safety precautions to minimize the chances of injury. Among many considerations, the following should be particularly noted:

- Blower casing and associated piping or accessories may become hot enough to cause major skin burns on contact.
- Internal and external rotating parts of the blower and driving equipment can produce serious physical injuries. Do not reach into any opening in the blower while it is operating, or while subject to accidental starting. Protect external moving parts with adequate guards.
- Disconnect power before doing any work, and avoid bypassing or rendering inoperative any safety or protective devices.
- If blower is operated with piping disconnected, place a strong coarse screen over the inlet and avoid standing in the discharge air stream.

CAUTION: Never cover the blower inlet with your hand or other part of body.

- Stay clear of inlet and discharge openings.
- Stay clear of the blast from pressure relief valves and the suction area of vacuum relief valves.
- Use proper care and good procedures in handling, lifting, installing, operating and maintaining the equipment.
- Casing pressure must not exceed 25 PSI (1725 mbar) gauge. Do not pressurize vented cavities from an external source, nor restrict the vents without first consulting ROOTS.
- Do not use air blowers on explosive or hazardous gases.
- Other potential hazards to safety may also be associated with operation of this equipment. All personnel working in or passing through the area should be trained to exercise adequate general safety precautions.

OPERATING LIMITATIONS

A ROOTS™ blower or exhauster must be operated within certain approved limiting conditions to enable continued satisfactory performance. Warranty is contingent on such operation.

Maximum limits for pressure, temperature and speed are specified in TABLE 1 for various models & sizes of blowers & exhausters. These limits apply to all units of normal construction, when operated under standard atmospheric conditions. Be sure to arrange connections or taps for thermometers and pressure or vacuum gauges at or near the inlet and discharge connections of the unit. These, along with a good tachometer, will enable periodic checks of operating conditions.

PRESSURE – The pressure rise, between inlet and discharge, must not exceed the figure listed for the specific unit frame size concerned. Also, in any system where the unit inlet is at a positive pressure above atmosphere a maximum case rating of 25 PSI gauge (1725 mbar) should not be exceeded without first consulting the ROOTS. Never should the maximum allowable differential pressure be exceeded.

On vacuum service, with the discharge to atmospheric pressure, the inlet suction or vacuum must not be greater than values listed for the specific frame size.

TEMPERATURE – Blower & exhauster frame sizes are approved only for installations where the following temperature limitations can be maintained in service:

- Measured temperature rise must not exceed listed values when the inlet is at ambient temperature. Ambient is considered as the general temperature of the space around the unit. This is not outdoor temperature unless the unit is installed outdoors.
- If inlet temperature is higher than ambient, the listed allowable temperature rise values must be **reduced** by 2/3 of the difference between the actual measured inlet temperature and the ambient temperature.
- The average of the inlet and discharge temperature must not exceed 250°F. (121°C).

SPEED – These blowers & exhausters may be operated at speeds up to the maximum listed for the various frame sizes. They may be direct coupled to suitable constant speed drivers if pressure/temperature conditions are also within limits. At low speeds, excessive temperature rise may be a limiting factor.

Special Note: The listed maximum allowable temperature rise for any particular blower & exhauster may occur well before its maximum pressure or vacuum rating is reached. This may occur at high altitude, low vacuum or at very low speed. The units' operating limit is always determined by the maximum rating reached first. It can be any one of the three: Pressure, Temperature or Speed.

INSTALLATION

ROOTS™ blowers & exhausters are treated after factory assembly to protect against normal atmospheric corrosion. The maximum period of internal protection is considered to be one year under average conditions, if shipping plugs & seals are not removed. Protection against chemical or salt water atmosphere is not provided. Avoid opening the unit until ready to start installation, as corrosion protection will be quickly lost due to evaporation.

If there is to be an extended period between installation and start up, the following steps should be taken to ensure corrosion protection.

- Coat internals of cylinder, gearbox and drive end bearing reservoir with Nox-Rust VCI-10 or equivalent. Repeat once a year or as conditions may require. Nox-Rust VCI-10 is petroleum soluble and does not have to be removed before lubricating. It may be obtained from Daubert Chemical Co., 2000 Spring Rd., Oak Brook, Ill. 60521.
- Paint shaft extension, inlet and discharge flanges, and all other exposed surfaces with Nox-Rust X-110 or equivalent.
- Seal inlet, discharge, and vent openings. It is not recommended that the unit be set in place, piped to the system, and allowed to remain idle for extended periods. If any part is left open to the atmosphere, the Nox-Rust VCI-10 vapor will escape and lose its effectiveness.
- Protect units from excessive vibration during storage.
- Rotate shaft three or four revolutions every two weeks.
- Prior to start up, remove flange covers on both inlet and discharge and inspect internals to insure absence of rust. Check all internal clearances. Also, at this time, remove gearbox and drive end bearing cover and inspect gear teeth and bearings for rust.

Because of the completely enclosed unit design, location of the installation is generally not a critical matter. A clean, dry and protected indoor location is preferred. However, an outdoor location will normally give satisfactory service. Important requirements are that the correct grade of lubricating oil be provided for expected operating temperatures, and that the unit be located so that routine checking and servicing can be performed conveniently. Proper care in locating driver and accessory equipment must also be considered.

Supervision of the installation by a ROOTS Service Engineer is not usually required for these units. Workmen with experience in installing light to medium weight machinery should be able to produce satisfactory results. Handling of the equipment needs

to be accomplished with care, and in compliance with safe practices. Unit mounting must be solid, without strain or twist, and air piping must be clean, accurately aligned and properly connected.

Bare-shaft Units: Two methods are used to handle a unit without base. One is to use lifting lugs bolted into the top of the unit headplates. Test them first for tightness and fractures by tapping with a hammer. In lifting, keep the direction of cable pull on these bolts as nearly vertical as possible. If lifting lugs are not available, lifting slings may be passed under the cylinder adjacent to the headplates. Either method prevents strain on the extended drive shaft.

Packaged Units: When the unit is furnished mounted on a baseplate, with or without a driver, use of lifting slings passing under the base flanges is required. Arrange these slings so that no strains are placed on the unit casing or mounting feet, or on any mounted accessory equipment. **DO NOT** use the lifting lugs in the top of the unit headplates.

Before starting the installation, remove plugs, covers or seals from unit inlet and discharge connections and inspect the interior completely for foreign material. If cleaning is required, finish by washing the cylinder, headplates and impeller thoroughly with a petroleum solvent. Turn the drive shaft by hand to make sure that the impellers turn freely at all points. Anti-rust compound on the connection flanges and drive shaft extension may also be removed at this time with the same solvent. Cover the flanges until ready to connect piping.

Mounting

Care will pay dividends when arranging the unit mounting. This is especially true when the unit is a "bare-shaft" unit furnished without a baseplate. The convenient procedure may be to mount such a unit directly on a floor or small concrete pad, but this generally produces the least satisfactory results. It definitely causes the most problems in leveling and alignment and may result in a "Soft Foot" condition. Correct soft foot before operation to avoid unnecessary loading on the casing and bearings. Direct use of building structural framing members is not recommended.

For blowers without a base, it is recommended that a well anchored and carefully leveled steel or cast iron mounting plate be provided. The plate should be at least 1 inch (25 mm) thick, with its top surface machined flat, and large enough to provide leveling areas at one side and one end after the unit is mounted. It should have properly sized studs or tapped holes located to match the unit foot drilling. Proper use of a high quality machinist's level is necessary for adequate installation.

With the mounting plate in place and leveled, set the unit on it without bolting and check for rocking. If it is not solid, determine the total thickness of shims required under one foot to stop rocking. Place half of this under each of the diagonally-opposite short feet, and tighten the mounting studs or screws. Rotate the drive shaft to make sure the impellers turn freely. If the unit is to be direct coupled to a driving motor, consider the height of the motor shaft and the necessity for it to be aligned very accurately with the unit shaft. Best unit arrangement is directly bolted to the mounting plate while the driver is on shims of at least 1/8 inch (3mm) thickness. This allows adjustment of motor position in final shaft alignment by varying the shim thickness.

Aligning

When unit and driver are factory mounted on a common baseplate, the assembly will have been properly aligned and is to be treated as a unit for leveling purposes. Satisfactory installation can be obtained by setting the baseplate on a concrete slab that is rigid and free of vibration, and leveling the top of the base carefully in two directions so that it is free of twist. The slab must be provided with suitable anchor bolts. The use of grouting under and partly inside the leveled and shimmed base is recommended.

It is possible for a base-mounted assembly to become twisted during shipment, thus disturbing the original alignment. For this reason, make the following checks after the base has been leveled and bolted down. Disconnect the drive and rotate the unit shaft by hand. It should turn freely at all points. Loosen the unit foot hold-down screws and determine whether all feet are evenly in contact with the base. If not, insert shims as required and again check for free impeller rotation. Finally, if unit is direct coupled to the driver, check shaft and coupling alignment carefully and make any necessary corrections.

In planning the installation, and before setting the unit, consider how piping arrangements are dictated by the unit design and assembly. Drive shaft rotation must be established accordingly and is indicated by an arrow near the shaft.

Typical arrangement on vertical units has the drive shaft at the top with counterclockwise rotation and discharge to the left. Horizontal units are typically arranged with the drive shaft at the left with counterclockwise rotation and discharge down. See Figure 4 for other various unit arrangements and possible conversions.

When a unit is DIRECT COUPLED to its driver, the driver RPM must be selected or governed so as not to exceed the maximum speed rating of the unit. Refer to Table 1 for allowable speeds of various unit sizes.

A flexible type coupling should always be used to connect the driver and unit shafts.

When direct coupling a motor or engine to a blower you must insure there is sufficient gap between the

coupling halves and the element to prevent thrust loading the blower bearings. When a motor, engine or blower is operated the shafts may expand axially. If the coupling is installed in such a manner that there is not enough room for expansion the blower shaft can be forced back into the blower and cause the impeller to contact the gear end headplate resulting in damage to the blower. The two shafts must be in as near perfect alignment in all directions as possible, and the gap must be established with the motor armature on its electrical center if end-play exists.

The following requirements of a good installation are recommended. When selecting a coupling to be fitted to the blower shaft ROOTS recommends a taper lock style coupling to insure proper contact with the blower shaft. Coupling halves must be fitted to the two shafts with a line to line thru .001" interference fit. Coupling halves must be warmed up per coupling manufacturer's recommendations. Maximum deviation in offset alignment of the shafts should not exceed .005" (.13 mm) total indicator reading, taken on the two coupling hubs. Maximum deviation from parallel of the inside coupling faces should not exceed .001" (.03 mm) when checked at six points around the coupling.

When a unit is BELT DRIVEN, the proper selection of sheave diameters will result in the required unit speed. When selecting a sheave to be fitted to the blower shaft ROOTS recommends a taper lock style sheave to insure proper contact with the blower shaft. This flexibility can lead to operating temperature problems caused by unit speed being too low. Make sure the drive speed selected is within the allowable range for the specific unit size, as specified under Table 1.

Belt drive arrangements usually employ two or more V-belts running in grooved sheaves. Installation of the driver is less critical than for direct coupling, but its shaft must be level and parallel with the unit shaft.

The driver should be mounted on the inlet side of a vertical unit (horizontal piping) and on the side nearest to the shaft on a horizontal unit. The driver must also be mounted on an adjustable base to permit installing, adjusting and removing the V-belts. To position the driver correctly, both sheaves need to be mounted on their shafts and the nominal shaft center distance known for the belt lengths to be used.

CAUTION: Drive couplings and sheaves (pulleys) should have an interference fit to the shaft of the blower (set screw types of attachment generally do not provide reliable service.) It is recommended that the drive coupling or sheave used have a taper lock style bushing which is properly sized to provide the correct interference fit required. Drive couplings, that require heating to fit on the blower shaft, should be installed per coupling manufacturer recommendations. A drive coupling or sheave should not be forced on to the shaft of the blower as this could affect internal clearances resulting in damage to the blower. Engine

drive applications often require special consideration to drive coupling selection to avoid harmful torsional vibrations. These vibrations may lead to blower damage if not dampened adequately. It is often necessary to install a fly-wheel and/or a torsionally soft elastic element coupling based on the Engine manufacturer recommendations.

The driver sheave should also be mounted as close to its bearing as possible, and again should fit the shaft correctly. Position the driver on its adjustable base so that 2/3 of the total movement is available in the direction away from the unit, and mount the assembly so that the face of the sheave is accurately in line with the unit sheave. This position minimizes belt wear, and allows sufficient adjustment for both installing and tightening the belts. After belts are installed, adjust their tension in accordance with the manufacturer's instructions. However, only enough tension should be applied to prevent slippage when the unit is operating under load. Excessive tightening can lead to early bearing failures or shaft breakage.

Before operating the drive under power to check initial belt tension, first remove covers from the unit connections. Make sure the interior is still clean, then rotate the shaft by hand. Place a coarse screen over the inlet connection to prevent anything being drawn into the unit while it is operating, and avoid standing in line with the discharge opening. Put oil in the sumps per instructions under **LUBRICATION**.

Piping

Before connecting piping, remove any remaining anti-rust compound from Unit connections. Clean pipe should be no smaller than unit connections. In addition, make sure it is free of scale, cuttings, weld beads, or foreign material of any kind. To further guard against damage to the unit, especially when an inlet filter is not used, install a substantial screen of 16 mesh backed with hardware cloth at or near the inlet connections. Make provisions to clean this screen of collected debris after a few hours of operation. It should be removed when its usefulness has ended, as the wire will eventually deteriorate and small pieces going into the unit may cause serious damage.

Pipe flanges or male threads must meet the unit connections accurately and squarely. **DO NOT** attempt to correct misalignment by springing or cramping the pipe. In most cases this will distort the unit casing and cause impeller rubbing. In severe cases it can prevent operation or result in a broken drive shaft. For similar

reasons, piping should be supported near the unit to eliminate dead weight strains. Also, if pipe expansion is likely to occur from temperature change, installation of flexible connectors or expansion joints is advisable.

Figure 3 represents an installation with all accessory items that might be required under various operating conditions. Inlet piping should be completely free of valves or other restrictions. When a shut-off valve can not be avoided, make sure a full size vacuum relief is installed nearest the unit inlet. This will protect against unit overload caused by accidental closing of the shut-off valve.

Need for an inlet silencer will depend on unit speed and pressure, as well as sound-level requirements in the general surroundings. An inlet filter is recommended, especially in dusty or sandy locations. A discharge silencer is also normally suggested, even though Whispair units operate at generally lower noise levels than conventional rotary blowers. Specific recommendations on silencing can be obtained from ROOTS.

Discharge piping requires a pressure relief valve, and should include a manual unloading valve to permit starting the unit under no-load conditions. Reliable pressure/vacuum gauges and good thermometers at both inlet and discharge are recommended to allow making the important checks on unit operating conditions. The back-pressure regulator shown in Figure 3 is useful mainly when volume demands vary while the unit operates at constant output. If demand is constant, but somewhat lower than the unit output, excess may be blown off through the manual unloading valve.

In multiple unit installations where two or more units operate with a common header, use of check valves is mandatory. These should be of a direct acting or free swinging type, with one valve located in each line between the unit and header. Properly installed, they will protect against damage from reverse rotation caused by air and material back-flow through an idle unit.

After piping is completed, and before applying power, rotate the drive shaft by hand again. If it does not move with uniform freedom, look for uneven mounting, piping strain, excessive belt tension or coupling misalignment.

DO NOT operate the unit at this time unless it has been lubricated per instructions.

LUBRICATION

LUBRICATION: For Units with Splash Lubrication on Both Ends

Bearings and oil seals are lubricated by the action of the timing gears or oil slingers which dip into the main oil sumps causing oil to splash directly on gears and into bearings and seals. A drain port is provided below each bearing to prevent an excessive amount of oil in the bearings. Seals located inboard of the bearings in each headplate effectively retain oil within the sumps. Any small leakage that may occur should the seals wear passes into a cavity in each vented headplate and is drained downward.

Oil sumps on each end of the blower are filled by removing top vent plugs, Item (21), and filling until oil reaches the middle of the oil level sight gauge, Item (37).

Initial filling of the sumps should be accomplished with the blower not operating, in order to obtain the correct oil level. Approximate oil quantities required for blowers of the various models and configurations are listed in Table 3. Use a good grade of **industrial type** non-detergent, rust inhibiting, anti-foaming oil and of correct viscosity per Table 2. *ROOTS™ synthetic oil (ROOTS P/N 813-106-) is highly recommended. ROOTS™ does **NOT** recommend automotive type lubricants, as they are not formulated with the properties mentioned above.

The oil level should not fall below the middle of the site gauge when the blower is idle. It may rise or fall on the gauge during operation, to an extent depending somewhat on oil temperature and blower speed.

Proper lubrication is usually the most important single consideration in obtaining maximum service life and satisfactory operation from the unit. Unless operating conditions are quite severe, a weekly check of oil level and necessary addition of lubricant should be sufficient. During the first week of operation, check the oil levels in the oil sumps about once a day, and watch for leaks. Replenish as necessary. Thereafter, an occasional check should be sufficient. It is recommended that the oil be changed after initial 100 hours of operation. Frequent oil changing is not necessary unless the blower is operated in a very dusty location.

Normal life expectancy of petroleum based oils is about 2000 hours with an oil temperature of about 180°F (82°C). As the oil temperature increases by increments of 15-18°F (8°C - 10°C), the life is reduced by half. Example: Oil temperatures of 210-216°F (99°C - 102°C) will produce life expectancy of 1/4 or 500 hours. Therefore, it is considered normal to have oil change periods of 500 hours with petroleum based oils.

Normal life expectancy of ROOTS™ Synthetic Oil is about 4000 to 8000 hours with an oil temperature of about 180°F (82°C). As the oil temperature increases by increments of 15-18°F (8°C - 10°C), the life is reduced by half. Example: Oil temperatures of 210-216°F (99°C - 102°C) will produce life expectancy of 1/4 or 1000 to 2000 hours.

NOTE: To estimate oil temperature, multiply the discharge temperature of the blower by 0.80. Example: if the discharge air temperature of the blower is 200° F, it is estimated that the oil temperature is 160° F.

*ROOTS™ Synthetic Oil is superior in performance to petroleum based products. It has high oxidation stability, excellent corrosion protection, extremely high film strength and low coefficient of friction. Typical oil change intervals are increased 2-3 times over petroleum based lubricants. Also, ROOTS™ Synthetic Oil is 100% compatible with petroleum based oils. Simply drain the oil in the blower and refill the reservoirs with ROOTS™ Synthetic Oil to maintain optimum performance of your ROOTS™ blower.

OPERATION

Before operating a blower under power for the first time, recheck the unit and the installation thoroughly to reduce the likelihood of avoidable troubles. Use the following procedure check list as a guide, but consider any other special conditions in the installation.

- Be certain that no bolts, tools, rags, or debris have been left in the blower air chamber or piping.
- If an outdoor intake without filter is used, be sure the opening is located so it cannot pick up dirt and is protected by a strong screen or grille. Use of the temporary protective screen as described under **INSTALLATION** is strongly recommended.
- Recheck blower leveling, drive alignment and tightness of all mounting bolts if installation is not recent. If belt drive is used, adjust belt tension correctly.
- Turn drive shaft by hand to make sure impellers still rotate without bumping or rubbing at any point.
- Ensure oil levels in the main oil sumps are correct.
- Check lubrication of driver. If it is an electric motor, be sure that power is available and that electrical overload devices are installed and workable.
- Open the manual unloading valve in the discharge air line. If a valve is in the inlet piping, be sure it is open.
- Bump blower a few revolutions with driver to check that direction of rotation agrees with arrow near blower shaft, and that both coast freely to a stop.

After the preceding points are cleared, blower is ready for trial operation under "no-load" conditions. The following procedure is suggested to cover this initial operation test period.

- a. Start blower, let it accelerate to full speed, then shut off. Listen for knocking sounds, both with power on and as speed slows down.
- b. After blower comes to a complete stop, repeat above, but let blower run 2 or 3 minutes. Check for noises, such as knocking sounds.
- c. After blower comes to a complete stop, operate blower for about 10 minutes unloaded. Check oil levels. Observe cylinder and headplate surfaces for development of hot spots such as burned paint, indicating impeller rubs. Be aware of any noticeable increase in vibration.

Assuming that all trials have been satisfactory, or that necessary corrections have been made, the blower should now have a final check run of at least one hour under normal operating conditions. After blower is restarted, gradually close the discharge unloading valve to apply working pressure. At this point it is recommended that a good pressure gauge or manometer be connected into the discharge line if not already provided, and that thermometers be in both inlet and discharge lines. Readings from these

instruments will show whether pressure or temperature ratings of the blower are being exceeded.

During the final run, check operating conditions frequently and observe the oil levels at reasonable intervals. If excessive noise or local heating develops, shut down immediately and determine the cause. If either pressure rise or temperature rise across the blower exceeds the limit specified in this manual, shut down and investigate conditions in the piping system. Refer to the **TROUBLESHOOTING CHECKLIST** for suggestions on various problems that may appear.

The blower should now be ready for continuous duty operation at full load. During the first few days make periodic checks to determine whether all conditions remain steady, or at least acceptable. This may be particularly important if the blower is supplying air to a process system where conditions can vary. At the first opportunity, stop the blower and clean the temporary inlet protective screen. If no appreciable amount of debris has collected, the screen may be removed. See comments under **INSTALLATION**. At this same time, verify leveling, coupling alignment or belt tension, and mounting bolt tightness.

Should operating experience prove that blower capacity is a little too high for the actual air requirements, a small excess may be blown off continuously through the manual unloading or vent valve. Never rely on the pressure relief valve as an automatic vent. Such use may cause the discharge pressure to become excessive, and can also result in failure of the valve itself. If blower capacity appears to be too low, refer to the **TROUBLESHOOTING CHECKLIST**.

Vibration Assessment Criteria

With measurements taken at the bearing locations on the housings, see chart below for an appropriate assessment guide for rotary lobe blowers rigidly mounted on stiff foundations.

In general, blower vibration levels should be monitored on a regular basis and the vibration trend observed for progressive or sudden change in level. If such a change occurs, the cause should be determined through spectral analysis.

As shown on the chart below, the level of all pass vibration will determine the need to measure discrete frequency vibration levels and the action required.

| All Pass Vibration (in/sec) | Discrete Frequency Vibration (in/sec) | Action |
|-----------------------------------|---------------------------------------|-------------|
| 0.45 or less | N/R | Acceptable |
| Greater than 0.45 but 1.0 or less | 0.45 or less @ any frequency | Acceptable |
| | Greater than 0.45 @ any frequency | Investigate |
| Greater than 1.0 | Less than 1.0 | Investigate |
| | Greater than 1.0 | Investigate |

OPERATING CHARACTERISTICS

ROOTS™ rotary blowers and exhausters, as covered in this manual, are available in basic frame sizes ranging from 4.5 inch to 6 inch gear diameter. Various models, within this gear diameter range, are available with different case lengths to produce reasonable steps in flow capacity. The shorter case lengths have lower volumetric capacities, but are capable of operating against higher pressures. All models are available for air service and there are specifically designed models for gas service.

The basic ROOTS™ rotary lobe blower is a positive displacement type unit. Flow capacity is determined by frame size, operating speed and pressure conditions. It employs two impellers mounted on parallel shafts rotating in opposite directions within a cylinder closed at the ends by head-plates. As the impellers rotate, gas is drawn into one side of the cylinder and forced out the opposite side. The pressure or vacuum developed depends on the resistance of the piping and process system.

The unit is a precision engineered product with very fine clearances between the rotating impellers and stationary case. Since there is no actual contact between these surfaces, internal lubrication is not required. Clearances are maintained by a pair of accurately machined timing gears, mounted on the two shafts extended outside the blower casing.

Operation of the familiar basic rotary lobe blower is illustrated in FIGURE 1, where air flow is left to right from inlet to discharge with the top impeller rotating clockwise. In Position 1 it is delivering a known volume (B) to the discharge, while space (A) between the lower impeller and cylinder wall is being filled. Counterclockwise rotation of this impeller then traps equal volume (A) in Position 2, and further rotation delivers it to the discharge in Position 3.

One complete revolution of the driving shaft alternately traps four fixed and equal volumes of air (two by each impeller) and pushes them through to the discharge. The volume capacity of a lobe blower operating at a constant speed therefore remains relatively independent of reasonable inlet or discharge pressure variations. To change capacity, it is necessary either to change speed of rotation or blow off some of the discharge air.

No attempt should ever be made to control capacity by means of a throttle valve in the intake or discharge piping. This will not only increase the power load on the driver, but can also overload and seriously damage the blower. If a possibility does exist that flow to the blower inlet may be cut off during normal operation of a process, then an adequate vacuum relief valve must be installed near the blower. A pressure type relief valve in the discharge line near the blower is required for protection against cut-off or blocking in this line. Refer to FIGURE 3 for a complete piping schematic.

When a belt drive is installed, blower speed can usually be adjusted to obtain desired capacity by changing the diameter of one or both sheaves. In a direct coupled arrangement a variable speed motor or transmission is required, or excess air may be blown off through a manually controlled unloading valve and silencer. If returned to the blower inlet, the air must be cooled to 100°F (38°C) through a by-pass arrangement to maintain acceptable blower temperatures.

Before making any change in blower capacity, or operating conditions, contact ROOTS for specific information applying to your particular blower. In all cases, operating conditions must be maintained within the approved range of pressures, temperatures and speeds as stated under **LIMITATIONS**. The air blower must not be used to handle liquids or solids as serious damage to the rotating parts may result.

FIGURE 1 – FLOW THROUGH A BASIC ROTARY LOBE BLOWER

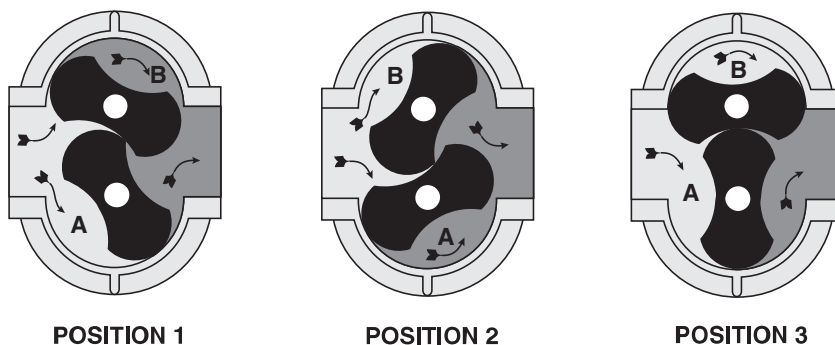

TROUBLESHOOTING

| Trouble | Item | Possible Cause | Remedy |
|---|------|---|--|
| No flow | 1 | Speed too low | Check by tachometer and compare with published performance |
| | 2 | Wrong rotation | Compare actual rotation with Figure 1 Change driver if wrong |
| | 3 | Obstruction in piping | Check piping, valves, silencer to assure open flow path |
| Low capacity | 4 | Speed too low | See item 1, If belt drive, check for slippage and readjust tension |
| | 5 | Excessive pressure rise | Check inlet vacuum and discharge pressure and compare with Published performance |
| | 6 | Obstruction in piping | See item 3 |
| | 7 | Excessive slip | Check inside of casing for worn or eroded surfaces causing excessive clearances |
| Excessive power | 8 | Speed too high | Check speed and compare with published performance |
| | 9 | Excessive pressure rise | See Item 5 |
| | 10 | Impeller rubbing | Inspect outside of cylinder for high temperature areas, then check for impeller contact at these points. Correct blower mounting, drive alignment |
| | 11 | Scale, sludge, rust or product build up | Clean blower appropriately |
| Damage to bearings or gears | 12 | Inadequate lubrication | Check oil sump levels in gear and drive end headplates |
| | 13 | Excessive lubrication | Check oil levels. If correct, drain and refill with clean oil of recommended grade |
| | 14 | Excessive pressure rise | See Item 5 |
| | 15 | Coupling misalignment | Check carefully. Realign if questionable |
| | 16 | Excessive belt tension | Readjust for correct tension |
| Vibration | 17 | Misalignment | See Item 15 |
| | 18 | Impellers rubbing | See Item 10 |
| | 19 | Worn bearings/gears | Check gear backlash and condition of bearings, and replace as indicated |
| | 20 | Unbalanced or rubbing impeller | Scale or process material may build up on casing and impellers, or inside impellers. Remove build-up to restore original clearances and impeller balance |
| | 21 | Driver or blower loose | Tighten mounting bolts securely |
| | 22 | Piping resonances | Determine whether standing wave pressure pulsations are present in the piping |
| | 23 | Scale/sludge build-ups | Clean out interior of impeller lobes to restore dynamic balance |
| | 24 | Casing strain | Re-work piping alignment to remove excess strain |
| Driver stops, or will not start | 25 | Impeller stuck | Check for excessive hot spot on headplate or cylinder. See item 10. Look for defective shaft bearing and/or gear teeth |
| | 26 | Scale, sludge, rust or product build-up | Clean blower appropriately |
| Excessive breather | 27 | Broken seal | Replace seals |
| Blow-by or excessive oil leakage to vent area | 28 | Defective O-ring | Replace seals and O-ring |
| Excessive oil leakage in vent area | 29 | Defective/plugged breather | Replace breather and monitor oil leakage |
| | 30 | Oil level too high | Check sump levels in gear and drive headplates. |
| | 31 | Oil type or viscosity incorrect | Check oil to insure it meets recommendations. Drain then fill with clean oil of recommended grade. |
| | 32 | Blower running hot | Recommended oil temperature can be found on page 6 of this manual. The blower must be operated within the conditions of this manual |

INSPECTION & MAINTENANCE: RAM™ AND RCS SERIES BLOWERS

A good program of consistent inspection and maintenance is the most reliable method of minimizing repairs to a blower. A simple record of services and dates will help keep this work on a regular schedule. Basic service needs are:

- Lubrication
- Checking for hot spots
- Checking for increases or changes in vibration and noise
- Recording of operating pressures and temperatures

Above all, a blower must be operated within its specified rating limits, to obtain satisfactory service life.

A newly installed blower should be checked often during the first month of full-time operation. Attention there after may be less frequent assuming satisfactory performance. Lubrication is normally the most important consideration and weekly checks of lubricant levels in the gearbox and bearing reservoirs should be customary. Complete oil change schedules are discussed under **LUBRICATION**.

Driver lubrication practices should be in accordance with the manufacturer's instructions. If direct connected to the blower through a lubricated type coupling, the coupling should be checked and greased each time blower oil is changed. This will help reduce wear and prevent unnecessary vibration. In a belted drive system, check belt tension periodically and inspect for frayed or cracked belts.

In a new, and properly installed, unit there is no contact between the two impellers, or between the impellers and cylinder or headplates. Wear is confined to the bearings (which support and locate the shafts) the oil seals, and the timing gears. All are lubricated and wear should be minimal if clean oil of the correct grade is always used. Seals are subject to deterioration and wear, and may require replacement at varying periods.

Piston ring seals (28) are designed to operate without rubbing contact, once temperature and thermal growth have stabilized. The stationary rings will rub the rotating sleeve (38) briefly as a result of temperature cycles that occur during the startup and shutdown of the unit. The sleeves are hardened and the rings are coated with dry lubricant that provides for temporary break in wear. Replace piston ring seals if they become excessively worn.

Shaft bearings are designed for optimum life under average conditions with proper lubrication and are critical to the service life of the blower. Gradual bearing wear may allow a shaft position to change slightly, until rubbing develops between impeller and casing. This will cause spot heating, which can be detected by observing these surfaces. Sudden bearing failure is usually more serious. Since the shaft and impeller are

no longer supported and properly located, extensive general damage to the blower casing and gears is likely to occur.

Oil seals should be considered expendable items, to be replaced whenever drainage from the headplate vent cavity becomes excessive or when the blower is disassembled for any reason. Some oil seal leakage may occur since an oil film under the lip is required for proper operation. Periodically leaked oil should be wiped off from surfaces. Minor seal leakage should not be considered as indicating seal replacement.

Timing gear wear, when correct lubrication is maintained, should be negligible over a period of years. Gear teeth are cut to provide the correct amount of backlash, and gears correctly mounted on the shafts will accommodate a normal amount of tooth wear without permitting contact between lobes of the two impellers. However, too high an oil level will cause churning and excessive heating. This is indicated by unusually high temperature at the bottom of the gear housing. Consequent heating of the gears will result in loss of tooth-clearance, backlash and rapid wear of the gear teeth usually will develop. Continuation of this tooth wear will eventually produce impeller contacts (knocking), and from this point serious damage will be unavoidable if blower operation is continued. A similar situation can be produced suddenly by gear tooth fracture, which is usually brought on by sustained overloading or momentary shock loads.

Problems may also develop from causes other than internal parts failure. Operating clearances within a blower are only a few thousandths of an inch. This makes it possible for impeller interferences or casing rubs to result from shifts in the blower mounting, or from changes in piping support. If this type of trouble is experienced, and the blower is found to be clean, try removing mounting strains. Loosen blower mounting bolts and reset the leveling and drive alignment. Then tighten mounting again, and make sure that all piping meets blower connections accurately and squarely. Foreign materials sucked into the blower will also cause trouble, which can only be cured by disconnecting the piping and thoroughly cleaning the blower interior.

A wide range of causes & solutions for operating troubles are covered in the **TROUBLE SHOOTING CHECKLIST**. The remedies suggested should be performed by qualified mechanics with a good background. Major repairs generally are to be considered beyond the scope of maintenance, and should be referred to **ROOTS**.

Warranty failures should not be repaired at all, unless specific approval has been obtained through a Sales Office or the factory before starting work. Unauthorized disassembly within the warranty period may void the warranty.

FIGURE 2

ALLOWABLE OVERHUNG LOADS FOR V-BELT DRIVES 400 - 600 RAM™ AND 400-600 RCS-V UNITS

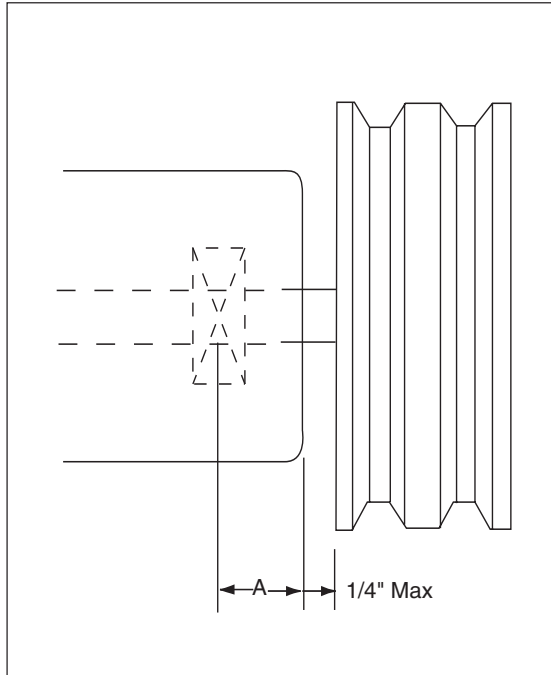

$$\text{Belt Pull lbs} = \frac{275000 \cdot \text{Motor HP}}{\text{Blower RPM} \cdot \text{Sheave Diameter}}$$

$$\text{Shaft Load (lb.in)} = \text{Belt Pull} \cdot \left(A + \frac{1}{4} + \frac{\text{Sheave Width}}{2} \right)$$

| Frame Size | Dimension "A" | | Min Sheave Diameter |
|---------------|---------------|-----------------------------------|---------------------|
| | Standard Unit | Max Allowable Shaft Load (lb-in.) | |
| 404, 406 | 1.90 | 3,200 | 7.10 |
| 409, 412, 418 | 1.90 | 3,200 | 7.10 |
| 616, 624 | 2.11 | 7,975 | 8.50 |

NOTE:

Arc of sheave belt contact on the smaller sheave not to be less than 170°

Driver to be installed on the inlet side for vertical units, and on the drive shaft side for horizontal units.

ROOTS recommends 3V, 5V or 8V belts and sheaves.

FIGURE 3
AIR BLOWER INSTALLATION WITH ACCESSORIES

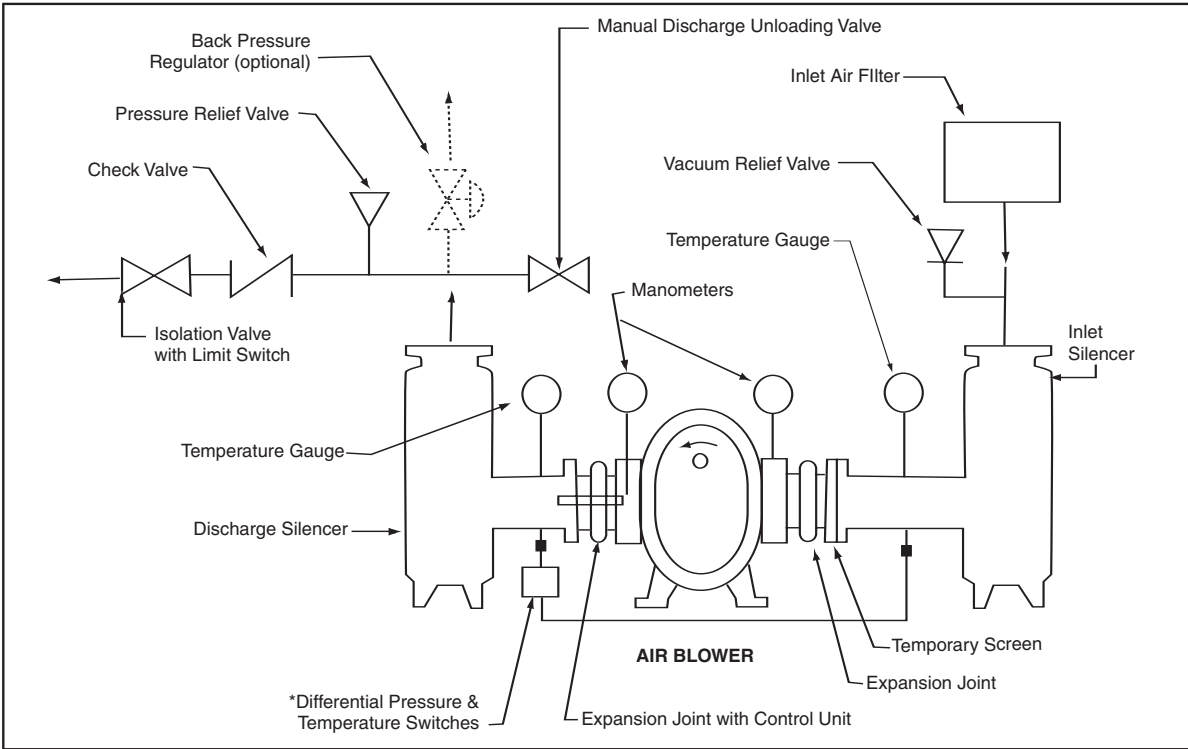

Above are suggested locations for available accessories.

FIGURE 4

BLOWER ORIENTATION CONVERSION - RAM WHISPAIR™ UNITS

1. STANDARD ARRANGEMENT (3-WAY UNIVERSAL)

EXTERNAL SIGHT GLASSES (37) & BREATHERS (21) MUST BE RELOCATED AS SHOWN.
FEET (76&77) & LIFTING LUGS (63) MUST BE RELOCATED AS SHOWN.

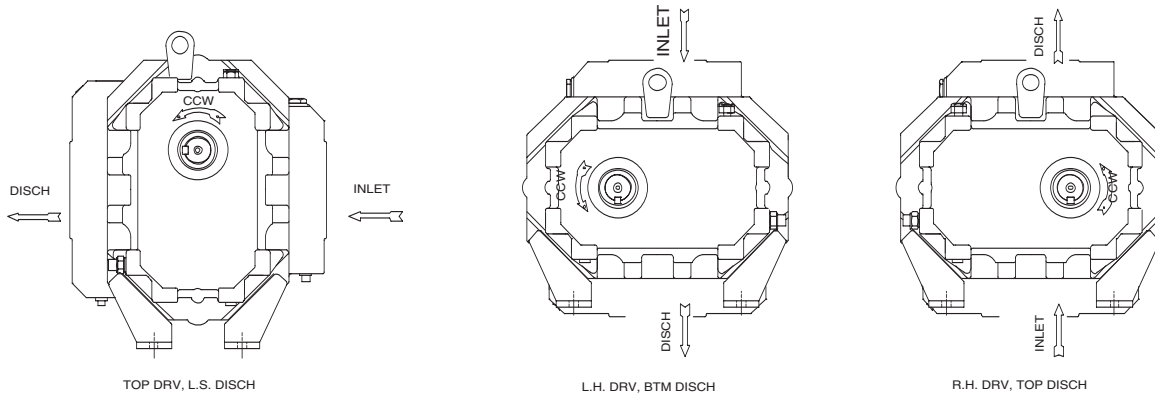

2. NON-STANDARD ARRANGEMENT (3-WAY UNIVERSAL)

CYLINDER (11) MUST BE UNBOLTED FROM HEADPLATES (1) AND DISCHARGE RELOCATED AS SHOWN. **MUST HAVE AUTHORIZATION FOR CONVERSION SO NOT TO VOID WARRANTY.**

EXTERNAL SIGHT GLASSES (37) & BREATHERS (21) MUST BE RELOCATED ALSO.
FEET (76&77) & LIFTING LUGS (63) MUST BE RELOCATED AS SHOWN

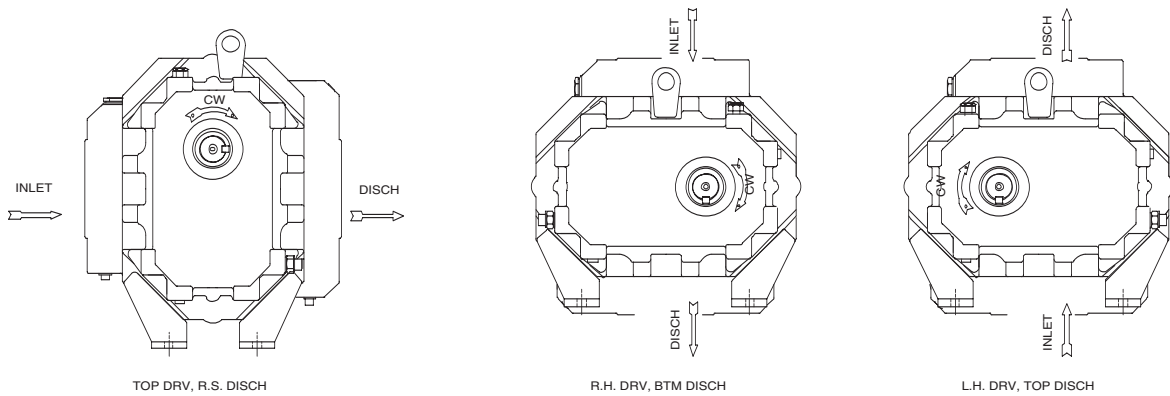

3. BOTTOM DRIVE SHAFT ARRANGEMENT "SPECIAL ORDER" (3-WAY UNIVERSAL)

SPECIAL OGE OIL SLINGER REQUIRED FOR ASSEMBLY.

MAY BE CONVERTED TO HORIZONTAL CONFIGURATION AS PREVIOUSLY SHOWN.

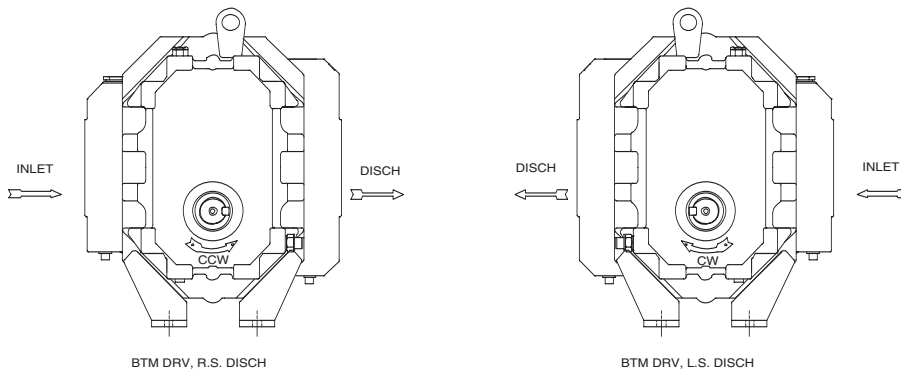

TABLE 1

**RAM™, RAM™-J WHISPAIR™ BLOWER
RCS, RCS-J WHISPAIR
MAXIMUM ALLOWABLE OPERATING CONDITIONS**

| Frame Size | Gear Diameter (Inch) | Speed RPM | Temp. Rise F° (C°) | Delta Pressure PSI (mbar) | Inlet Vacuum INHG (mbar) |
|------------|----------------------|-----------|--------------------|---------------------------|--------------------------|
| 404 | 4.5 | 4000 | 240 (133) | 18 (1241) | 16 (539) |
| 406 | 4.5 | 4000 | 240 (133) | 18 (1241) | 16 (539) |
| 409 | 4.5 | 4000 | 240 (133) | 18 (1241) | 16 (539) |
| 412 | 4.5 | 4000 | 240 (133) | 15 (1034) | 16 (539) |
| 418 | 4.5 | 4000 | 240 (133) | 10 (690) | 16 (539) |
| 616 | 6.0 | 3000 | 230 (128) | 15 (1034) | 16 (539) |
| 624 | 6.0 | 3000 | 230 (128) | 10 (690) | 16 (539) |

TABLE 2

RECOMMENDED OIL GRADES

| Ambient Temperature °F (°C) | ISO Viscosity No. |
|-----------------------------|-------------------|
| Above 90° (32°) | 320 |
| 32° to 90° (0° to 32°) | 220 |
| 0° to 32° (-18° to 0°) | 150 |
| Below 0° (-18°) | 100 |

Use a good grade of **industrial type** non-detergent, rust inhibiting, anti-foaming oil and of correct viscosity per Table 2. *ROOTS™ synthetic oil (ROOTS P/N 813-106-) is highly recommended. ROOTS™ does **NOT** recommend automotive type lubricants, as they are not formulated with the properties mentioned above.

TABLE 3

RAM™, RAM™-J APPROXIMATE OIL SUMP CAPACITIES

| Orientation | Gearbox | | Drive End | |
|------------------|---------|----------|-----------|----------|
| | Fl. Oz. | (Liters) | Fl. Oz. | (Liters) |
| 400 (Horizontal) | 36 | 1.06 | 19 | .56 |
| 400 (Vertical) | 18 | .52 | 9 | .27 |
| 600 (Horizontal) | 95 | 2.81 | 50 | 1.48 |
| 600 (Vertical) | 55 | 1.63 | 28 | 0.83 |

RCS-V, RCS-JV APPROXIMATE OIL SUMP CAPACITIES

| Orientation | Gearbox | | Drive End | |
|----------------|---------|----------|-----------|----------|
| | Fl. Oz. | (Liters) | Fl. Oz. | (Liters) |
| 400 (Vertical) | 30 | .089 | 18 | 0.53 |
| 600 (Vertical) | 64 | 1.89 | 32 | 0.95 |

These capacities are provided to assist stocking the correct amount of oil. Exact sump capacity may differ slightly. See "Lubrication" section for proper filling instructions.

**RAM™ SERIES PARTS LIST
4" & 6" GEAR DIAMETER**

(Refer to drawing #81881023)

| Item # | Part Name | Qty. |
|--------|----------------------------|------|
| 1 | Headplate | 2 |
| 3 | Gearbox | 1 |
| 4 | Timing Gears | 2 |
| 5 | End Cover | 1 |
| 7 | Gasket – Gearbox/Cover | 2 |
| 10 | Shims | Lot |
| 11 | Cylinder | 1 |
| 12 | Impeller & Shaft Drive | 1 |
| 13 | Impeller & Shaft Driven | 1 |
| 14 | Bearing Roller | 4 |
| 16 | Pin, Dowel (Pull Out) | 4 |
| 17 | Pin, Dowel | 2 |
| 19 | Key Square | 1 |
| 21 | Breather | 2 |
| 22 | Plug, Pipe | 12 |
| 23 | Screw, Cap Hex Hd. | * |
| 27 | Seal, Ben Binh. | 4 |
| 28 | Piston, Ring-Seal | 4 |
| 29 | Washer, Wavy Spring | 2 |
| 31 | Gear Nut | 2 |
| 32 | Scr, Cap Hex Hd. | 16 |
| 33 | Seal, Lip Drive | 1 |
| 34 | Brg. Clamp Plate - D. E. | 2 |
| 35 | Lock Washer - Spring | 16 |
| 37 | Sight Plug - Oil Level | 2 |
| 38 | Sleeve, Shaft | 4 |
| 40 | Slinger - D.E. (Top Drive) | 1 |
| 46 | Slinger - G.E. (Optional) | 1 |
| 49 | Oil Leader L/S | 1 |
| 50 | Oil, Leader-R/S | 1 |
| 54 | Brg Clamp Plate - G. E. | 2 |
| 60 | Screw, Cap Butt. HD. | 1 |
| 64 | Pin, Spring | 1 |
| 66 | Screw, Cap Hex HD. | * |
| 66.1 | Whispair, Spring Lock 3/8M | * |
| 70 | Shims D.E. Brg. | 1 |
| 75 | Screw, Cap - Hex HD. | * |
| 76 | Blower Foot - RH | 2 |
| 77 | Blower Foot - LH | 2 |
| 85 | Elb, Pipe-Black | 2 |
| 85.1 | Plug, Pipe | 2 |
| 87 | Scr, Cap BH | 2 |
| 88 | Anti Rotation Ball | 4 |
| 90 | BSHG-RDCG | 2 |
| 91 | Washer, Plain Flat | 2 |
| 92 | Washer, Plain Flat | 2 |
| 93 | Washer | 2 |

*Quantity varies by blower.

**RCS SERIES PARTS LIST
4" & 6" GEAR DIAMETER**

(Refer to drawing #65467023)

| Item # | Part Name | Qty. |
|--------|-------------------------|------|
| 1 | Headplate | 2 |
| 3 | Gearbox | 1 |
| 4 | Gear Assembly | 1 |
| 5 | Drive End Cover | 1 |
| 7 | Gasket | 2 |
| 8 | Nameplate | 1 |
| 9 | Lubrication Label | 2 |
| 10 | Shim Set | 1 |
| 11 | Cylinder | 1 |
| 12 | Impeller & Shaft Drive | 1 |
| 13 | Impeller & Shaft Driven | 1 |
| 14 | Bearing Roller | 4 |
| 16 | Pin, Dowel | 4 |
| 17 | Dri-Lok Pin | 2 |
| 19 | Key | 1 |
| 20 | Drive Screw | 2 |
| 21 | Plug - Vent | 2 |
| 22 | Drain - Filler Plug | 4 |
| 23 | Capscrew (400) | 34 |
| 23 | Capscrew (600) | 40 |
| 27 | Seal-Lip, Headplate | 4 |
| 28 | Seal Ring | 4 |
| 29 | Washer, Wavy Spring | 2 |
| 31 | Locknuts | 2 |
| 32 | Capscrew | 16 |
| 33 | Seal, Lip D. E. Cover | 1 |
| 34 | Clamp Plate, Drive End | 2 |
| 35 | Lock Washer | 16 |
| 37 | Oil Level Gauge | 2 |
| 38 | Sleeve | 4 |
| 40 | Slinger - D.E. | 1 |
| 45 | Pipe Plug | 2 |
| 46 | Slinger - G.E. | 1 |
| 49 | Oil Leader L/S | 1 |
| 50 | Oil, Leader-R/S | 1 |
| 54 | Clamp Plate, Gear End | 2 |
| 60 | Slinger Capscrew | 1 |
| 63 | Lifting Lug | 2 |
| 64 | Pin, Spring | 1 |
| 70 | Shim | 1 |
| 87 | Washer (600 only) | 1 |

SUGGESTED LUBRICANTS

ROOTS Synthetic Oil: ISO-VG-220 Grade

| | Part Number |
|---------------|-------------|
| Quart | 813-106-001 |
| Gallon | 813-106-002 |
| Case (12 qts) | 813-106-008 |

ROOTS Synthetic Oil: ISO-VG-320 Grade

| | |
|---------------|-------------|
| Quart | 813-106-004 |
| Gallon | 813-106-005 |
| Case (12 qts) | 813-106-007 |

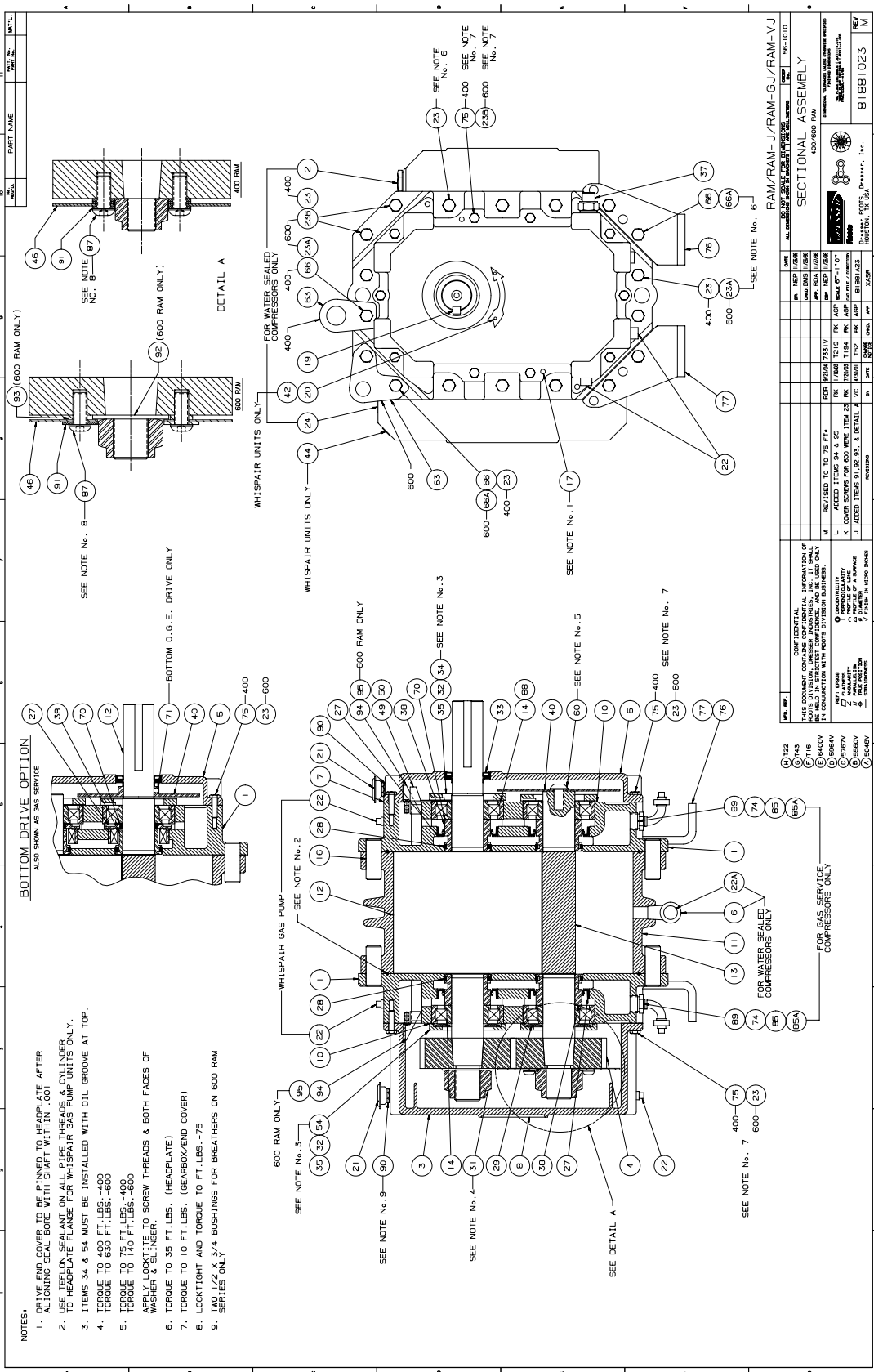

For your nearest ROOTS Office, dial our Customer Service Hot Line 1 877 363 ROOTS (7668).

ASSEMBLY OF RAM SERIES -AIR & GAS BLOWERS

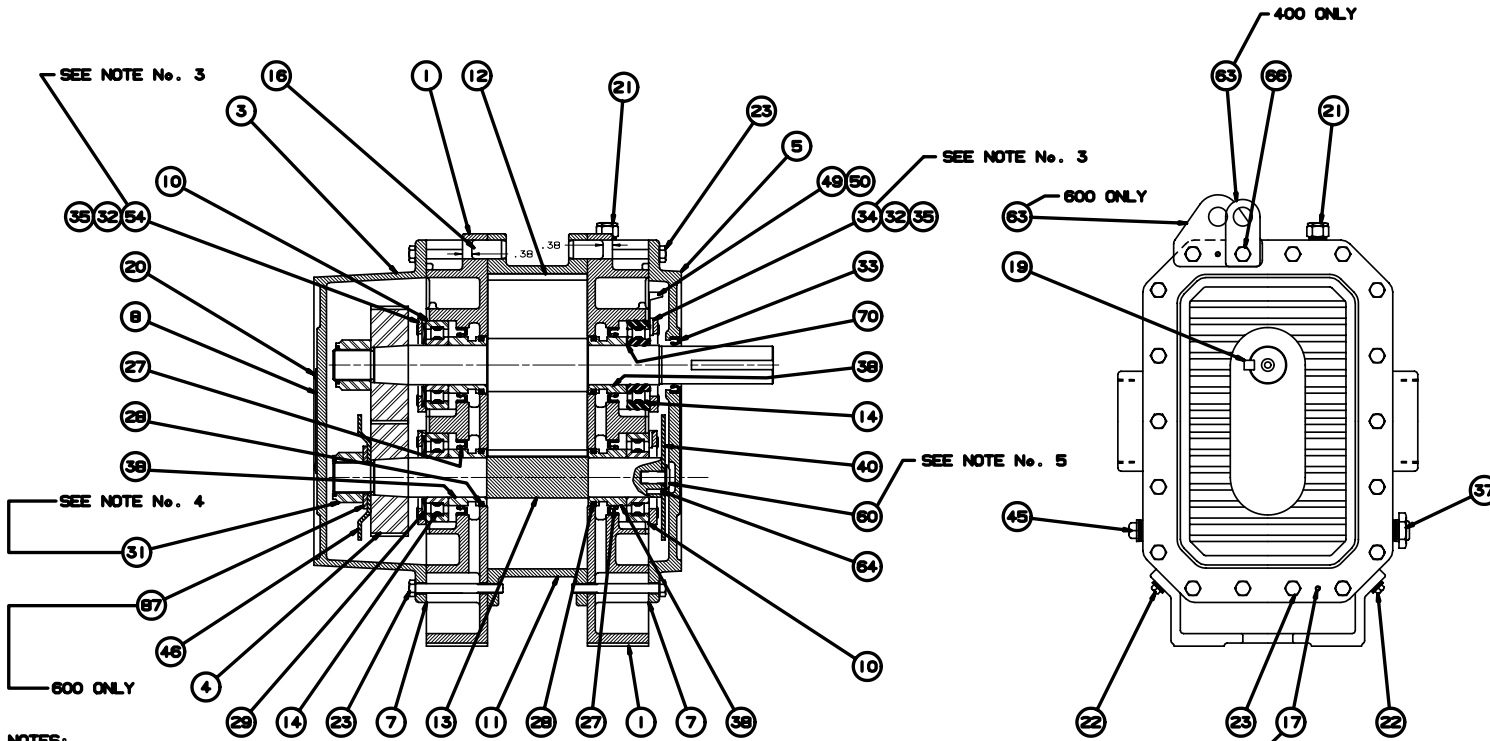

NOTES:

1. DRIVE END COVER TO BE PINNED TO HEADPLATE AFTER ALIGNING SEAL BORE WITH SHAFT WITHIN .001
2. USE JOHN CRANE PLASTIC LEAD No. 2 ON ALL PIPE THREADS
3. ITEMS 34 & 54 MUST BE INSTALLED WITH OIL GROOVE AT TOP
4. TORQUE: 400 RCS TO 400 LBS. FT.
600 RCS TO 630 LBS. FT.
5. TORQUE: 400 RCS TO 75 LBS. FT.
600 RCS TO 140 LBS. FT.

APPLY LOCKTITE TO SCREW THREADS AND BOTH FACES OF WASHER AND SLINGER

REF 6467023

G INCREASED GEAR NUT TORQUE JHB 3-29-88 3577-V DB 4/9-86
 F REVISED PER ECN RVE 10-27 3438-V FOR A/P FCR6-06-86
 E REVISED PER ECN RVE 10-27 3436-V DB ASP DLB6-07-86
 D ITEM #63 600 ONLY REVISED REM 10-27 3337-VFCR AP
 C REMOVED ITEM 36 WASHER REM 10-27 3337-VFCR AP
 B DOWEL PIN DIMENSION ADDED REM 10-27 3246-VFCR AP
 A ADDED 409 AND ABOVE REM 10-27 FCR AP PARTS/XXAS 6*110*

SECTIONAL ASSEMBLY
400 & 600 RCS-V

65467023

ASSEMBLY OF SERIES - RCS-V

CONTACT LIST

CUSTOMER SERVICE

Dresser ROOTS

2135 Hwy 6 South
Houston, TX 77077

Toll Free Hot Line: 1-877-363-ROOT(S) (7668)

Toll Free Fax: 1-877-357-7238

Local Fax: 281-966-4309

ROOTS Factory Service & Repair Center

11611B Tanner RD
Houston, TX 77041

Toll Free: 1-800-866-6182

Local Phone: 713-896-4810

Local Fax: 713-896-4927

Service & Warranty

Toll Free: 1-800-866-6182

Local Phone: 832-467-4614

Local Fax: 713-896-4927

Dresser, Inc.



Roots

IOM-185-205
February 2005

©2004 Dresser, Inc. all rights reserved.
ROOTS, RAM, and WHISPAIR are trademarks of Dresser, Inc.
Dresser Design is a registered trademark of Dresser, Inc.

Dresser ROOTS
2135 Hwy 6 South
Houston, TX 77077
PH: 281-966-4700
FX: 281-966-4309
Toll Free: 1-877-363-ROOT(S)

Dresser ROOTS - Connersville
900 West Mount Street
Connersville, IN 47331
PH: 765-827-9200
FX: 765-827-9266

Dresser ROOTS - Holmes Operation
PO Box B7
Off St. Andrews Rd
Turnbridge, Huddersfield
England HD1 6RB
PH: +44-1484-422222
FX: +44-1484-422668

website: www.rootsblower.com • email: ROOTS@dresser.com

PAGE LEFT BLANK



MODEL MSR-DC OIL BURNER



MODEL MSR-DC SPECIFICATIONS

FIRING CAPACITIES - MODEL MSR-DC

0.50 To 2.75 GALLONS PER HOUR

70,000 TO 385,000 BTU/HR INPUT

FUELS - MODEL MSR-DC

Use No. 1 or No. 2 Heating Oil (ASTM D-396), Kerosene, Diesel or Jp8 Jet Fuel.

NEVER attempt to use gasoline as a fuel for your burner, as it is more combustible and could result in a serious explosion.

NEVER burn garbage or refuse in the heating unit.

NEVER try to ignite by tossing burning paper or other materials into the heating unit.

NEVER burn waste or crankcase oil in the heating unit.

ELECTRICAL - MODEL MSR-DC

Power supply 13.0VDC Minimum (at Battery)

Motor 4500 RPM (Std) or 3950 RPM (low RPM), Ball Bearing, Permanent Magnet

Ignition 20,000V/28MA/50VA Secondary, Intermittent Duty Electronic Ignitor

DIMENSIONS - MSR-DC (Standard

Height.....12½"

Width13"

Depth6⅞"

FUEL UNIT

Suntec and DanFoss brands

MOUNTING

Rigid Flange, Adjustable Flange or Base mount.

DC OIL BURNER ELECTRICAL CONSIDERATIONS

- * Not all generators are equally capable. A minimum of 13.0 volts must be provided at the battery.
- * Generators should be operated at the maximum rated RPM during burner operation.
- * Good quality batteries are strongly suggested. Batteries with higher Cold Cranking Amp (CCA) rating and deep draw/marine type batteries are recommended.
- * Use automotive rated battery cabling. All other wiring should be OEM suggested wire type and gauge.
- * Protect all wiring connection points with dielectric grease.
- * Ambient temperature impacts electrical requirements. Higher temperatures will result in higher amp draws.
- * Increased pump operating pressure settings will increase amp draw.
- * Higher gallon rate nozzles and accompanying wider air band openings will increase amp draw.

INSTALLATION OF BURNER

INSTALLATION OF THE BURNER MUST BE DONE BY A QUALIFIED INSTALLER IN ACCORDANCE WITH REGULATIONS OF THE NATIONAL FIRE PROTECTION STANDARD FOR OIL-BURNING EQUIPMENT, NFPA NO. 31, AND IN COMPLETE ACCORDANCE WITH ALL LOCAL CODES AND AUTHORITIES HAVING JURISDICTION.

A QUALIFIED INSTALLER IS THE PERSON WHO IS RESPONSIBLE FOR THE INSTALLATION AND ADJUSTMENT OF THE EQUIPMENT AND WHO IS LICENSED TO INSTALL OIL-BURNING EQUIPMENT IN ACCORDANCE WITH ALL CODES AND ORDINANCES. WARRANTY IS VOIDED IF NOT INSTALLED BY SERVICE PERSON.

**THESE INSTRUCTIONS SHOULD BE AFFIXED TO THE BURNER
OR ADJACENT TO THE HEATING APPLIANCE.**



TO THE CLEANING EQUIPMENT OWNER

Since 1970, Wayne has supplied the hot water pressure washer cleaning equipment industry with oil burners. You are obtaining a quality burner unsurpassed in engineering design and product development. It will provide you with many years of efficient trouble-free operation, if properly installed and serviced. Please read this manual carefully.

Wayne warrants its burners specifically to those who have purchased it for resale, including your dealer. If, in any case, you have a problem with your burner, or its installation, you should contact your dealer or the cleaning equipment manufacturer for assistance.

FUEL UNITS AND OIL LINES

The model MSR-DC oil burner is provided with a single stage 3450 RPM fuel unit with by-pass plug removed for a single pipe installation; the by-pass plug for two pipe (inlet and return) is provided in the plastic bag attached to the fuel unit.

The installation of fuel filters are recommended. Check supply tank for sludge accumulation and leakage. Use only flare fittings on all piping and connections since compression fittings will eventually leak. With the system running, the vacuum should not exceed 12" mercury for single stage units. For ease of servicing, install a shut off valve near burner.

WIRING

The MSR-DC oil burner must be electrically wired and GROUNDED in accordance with local codes or in their absence, with National Electric Code ANS/NFPA No. 70-latest edition.

This oil burner requires a 12-volt DC power source. Use copper wire only not lighter than #12 awg. If a fused disconnect is used, it should be fused for a minimum of 20 amps. Refer to the wiring diagram in this manual or cleaning equipment manufacturers manual making sure the burner and controls are wired correctly.

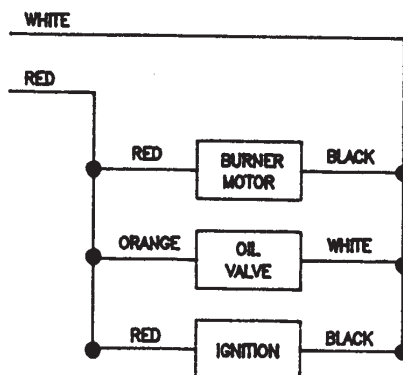

AIR SUPPLY FOR COMBUSTION

The oil burner fired hot water pressure washer shall not be installed in an area where facilities for normal air circulation or infiltration are so limited as to interfere with ready attainment of all necessary for proper combustion and venting. When the heating appliance is installed in a confined space, two permanent openings shall be provided. One near the top of the enclosure and one near the bottom. Each opening shall have a free area of not less than one square inch per 1000 BTU per hour (140 square inch per gph) of the total input rating of all the appliances in the enclosure. When the building is of unusually tight construction, has an air ventilating system, exhaust fans, process dryer or vented fireplaces, it is recommended that combustion air be supplied through two permanent openings. The openings shall communicate directly, or by means of ducts, with outdoors or such spaces (attic or crawl) that freely communicate with outdoors. Avoid linty environments. For additional venting information, refer to the regulations of the National Fire Protection Standard for oil burning equipment, ANSI/NFPA NO. 31-latest edition, or the cleaning equipment manufacturers recommendations.

NOZZLE AND AIR HANDLING PARTS SELECTION

IMPORTANT: Thorough combustion and performance testing was done to establish the correct nozzle type and air handling parts on this MSR-DC oil burner. Under circumstance attempt to replace or alter the oil burner nozzle type or air handling parts (stainless steel flamelock, air cone, electrode support style static disc, blower wheel or slotted air circumstances attempt to fire the MSR-DC oil burner under its 1.00 gph minimum or over its 2.75 gph maximum input rating.



To remove the gun assembly once the burner has been installed on the appliance remove the ignitor/housing cover screw and loosen the screw in the hold-down clip and swing open the transformer. Next, disconnect the copper oil line where it attaches with a 7/16" hex flare nut on the gun assembly oil line adapter fitting and remove the 9/16" hex gun assembly locknut. Now, grasp the rear of the gun assembly where the oil line fitting adapter exits through the housing and pull oil line fitting adapter to the right out of the housing slot and slot plate cover. Gently lift, do not force, the rear of the gun assembly, rotating the oil line fitting adapter up a 45 degrees pulling the entire gun assembly out of the air tube and housing opening.

The recommended can be installed into the nozzle body adapter using the following steps. With the gun assembly removed from the burner, loosen the electrode clamp screw and rotate the electrodes up, out of the way of a nozzle wrench. Now, thread the nozzle into the adapter finger tight then tighten securely with a nozzle wrench. **CAUTION:** Do not over tighten. Next, reposition the electrodes as shown in figure 1. At this time reinstall the gun assembly into the burner using the preceding steps in reverse order. Position the nozzle face forward to a 5/16" setting behind the stainless steel air cone as shown in figure 1. Once in the required position, replace the 9/16" hex lock nut and the 7/16" hex flare nut on the gun assembly and tighten the slot cover screw (see figure 2).

CAUTION: Close the ignitor and observe for spring contact with the brass buss bars, taking care not to pinch the ignition transformer lead wires between the housing and cover plate. Reinstall the ignitor/housing cover screw and tighten the screw in the hold down clip (see figure 2).

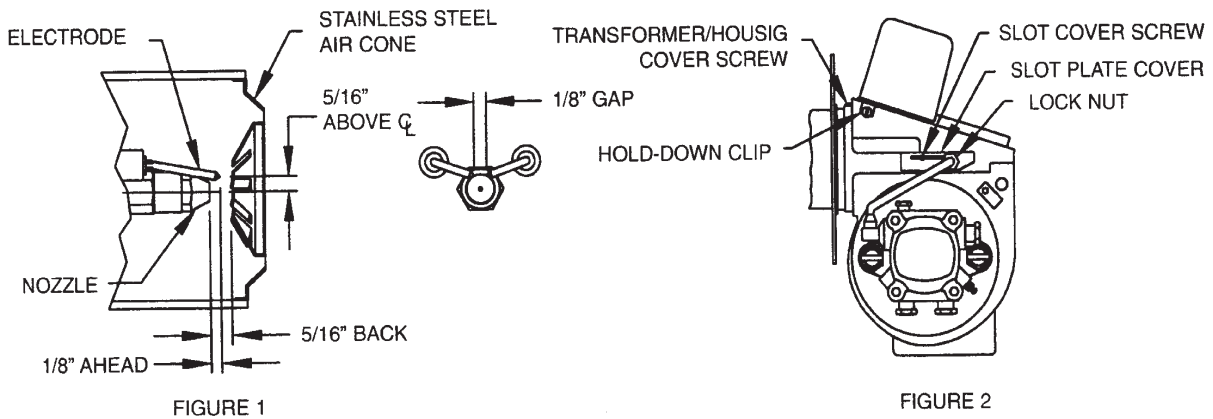

STARTING PROCEDURE

PREPARATION STEPS

1. Calibrate and check operation of combustion analysis equipment, CO₂ (carbon dioxide) or O₂ (oxygen) analyzer, smoke pump tester, fuel gas thermometer and oil pressure/vacuum gages. Follow the manufacture recommendation for proper calibration and check out.
2. Install oil pressure gage and vacuum gage in the outlet pressure and inlet ports of the fuel unit.
3. Set oil burner slotted air band shutter 25% open.

STARTING BURNER

1. Turn off the main power switch to the burner and appliance.
2. Be sure main fuel tank is filled and all manual valves are open between the fuel tank and the burner.
3. Turn on the main power switch to the burner and appliance.
4. Prime the fuel pump per its manufacturers recommendations, check fuel unit for 100 psi delivery pressure and check system vacuum (see paragraphs under Fuel Units and Oil Lines).

CAUTION: Do not run fuel unit dry for more than five minutes or damage to the fuel unit could result.



5. Once the fuel unit is primed (no signs of air in oil bleeder port discharge), close the bleed port. Burner will ignite.
6. When flame is established, make a temporary air adjustment to the slotted air band for a visually clean combustion smoke observed from the appliance vent. Allow the appliance to warm up approximately five minutes or until the water temperature reaches that recommended by the cleaning equipment manufacture.
7. Adjust the slotted air band shutter until a #1 to #2 smoke (Shell Bacharach scale) is obtained at the appliance vent.
8. Check CO₂ (carbon dioxide) and/or O₂ (oxygen) percentages and smoke in the flue gas at the appliance vent. In general, CO₂ readings should be in the 10% to 12% range and O₂ readings in the 7.4% to 4.7% range.
9. Once the desired combustion results are attained, securely tighten slotted air band screw and check that controls on the appliance are adjusted per the cleaning equipment manufactures instruction sheets. Remove oil pressure and vacuum gages from the fuel unit and reinstall pipe plug fittings.
10. Check burner lighting with hot chamber, then allow burner and appliance to sufficiently cool. Then check burner lighting with a cold chamber.

SUGGESTION: all new installations should be reinspected after one or two weeks of normal operation.

MAINTENANCE

OILING MOTOR – The MSR_DC oil burner is provided with a ball bearing shaft motor. Ball-bearing motors do not require oiling under normal service conditions.

FILTER – The oil filter cartridge should be replaced, or sediment cleaned, periodically so the fuel oil will not become contaminated and plug up the fuel pump and nozzle of oil burner.

NOZZLE – The nozzle should be changed at least once each year or twice a year if the cleaning equipment is used daily through the year and should poor combustion occur. Replace with the proper nozzle.

COMPONENTS – If for any reason any of the burner parts have to be replaced, always use parts recommended by the manufacturer. Specify part numbers and description when ordering. (IN ALL COMMUNICATIONS STATE BURNER MODEL AND SIX DIGIT SPECIFICATION NUMBER).

ELECTRODE SETTINGS – This is very important for reliable ignition of the oil; check these once a year in accordance with the instructions provided in this manual. Replace electrodes if worn excessively or if porcelain insulator is oil soaked or cracked (See Figure 1).

FAN & BLOWER HOUSING – This must be kept clean, free of dirt and lint; open transformer to check fan blades from above. Be sure the electric power is off on burner when the transformer is opened up for this inspection. Should the blower wheel be removed for replacement or cleaning, reinstall as shown in figure 3.

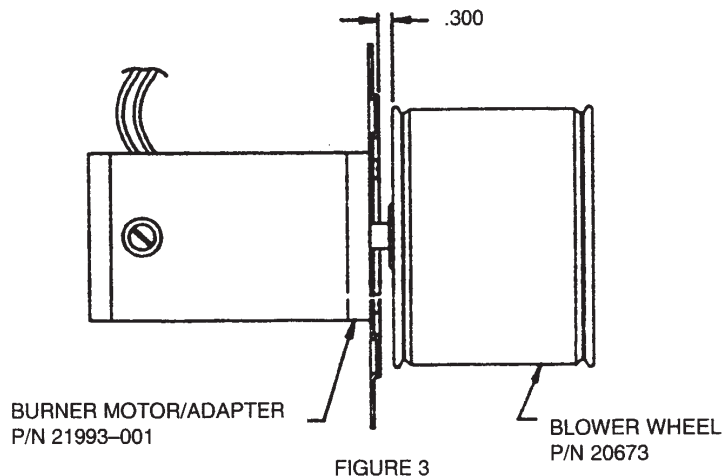



BURNER COMPONENTS - MODEL MSR-DC

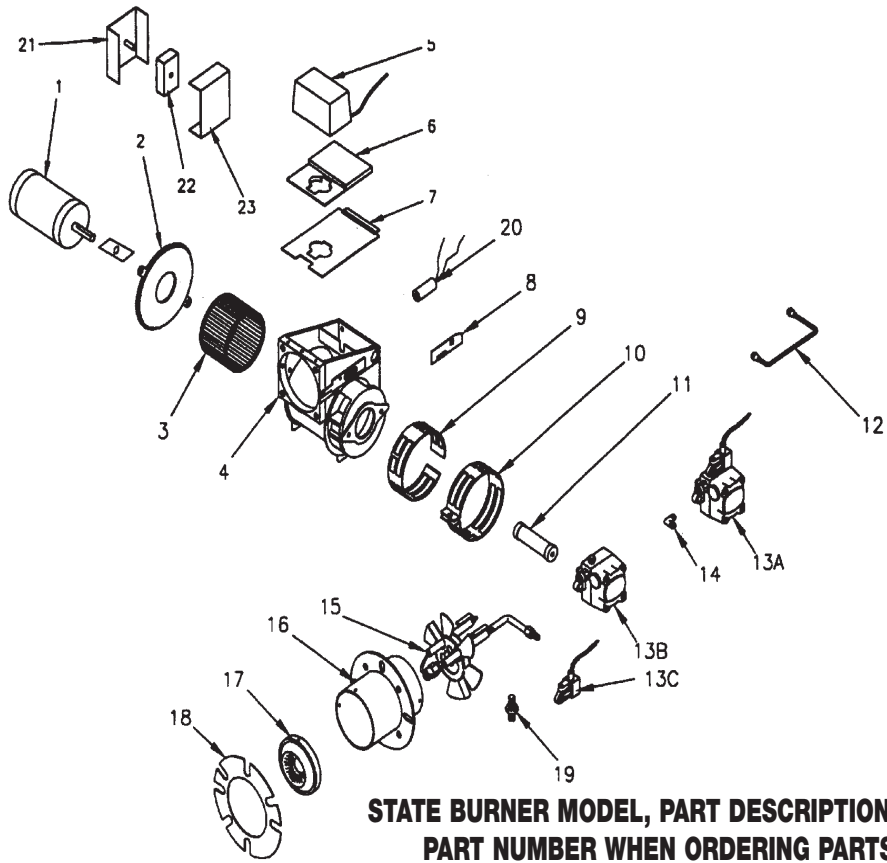

AIR TUBE & GUN ASSEMBLY DETAILS MODEL MSR-DC

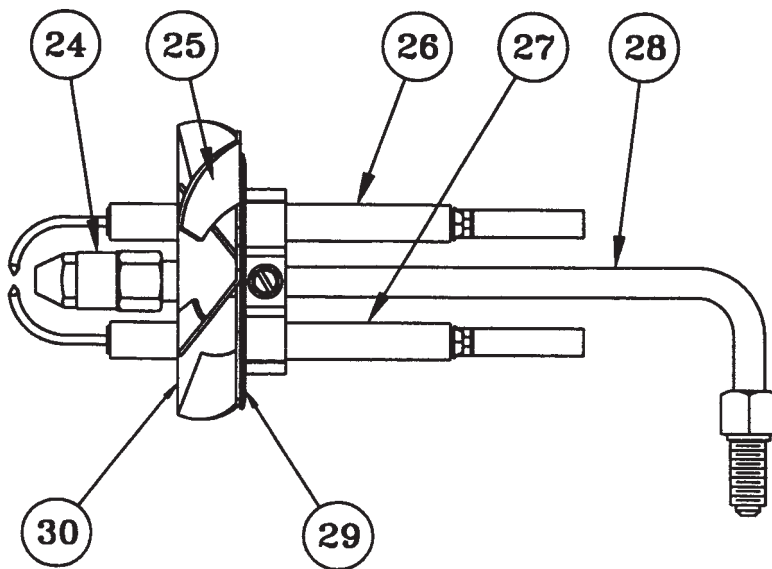

| ITEM | QTY | PART # | DESCRIPTION |
|------|-----|-------------|-------------------------------|
| 1 | 1 | 8046448-1 | MOTOR 1/8 STANDARD |
| | 1 | | MOTOR 1/8 LOW AMP |
| 2 | 1 | 8046448-2 | MOTOR ADAPTER |
| 3 | 1 | 8046448-3 | BLOWER WHEEL 3 1/2 X 4 1/4 |
| 4 | 1 | 8046448-4 | BURNER HOUSING |
| 5 | 1 | 8046448-5 | IGNITOR - 12VDC |
| 6 | 1 | 8046448-6 | MOUNTING BASE |
| 7 | 1 | 8046448-7 | HOUSING COVER |
| 8 | 1 | 8046448-8 | SLOT COVER PLATE |
| 9 | 1 | 8046448-9 | INNER AIR BAND |
| 10 | 1 | 8046448-10 | OUTER AIR BAND |
| 11 | 1 | 8046448-11 | COUPLING |
| 12 | 1 | 8046448-12 | OIL LINE ASSEMBLY 6" |
| | 1 | | OIL LINE ASSEMBLY 8" |
| 13 | 1 | 8046448-13A | FUEL UNIT: SUNTEC COMBO |
| | 1 | 8046448-13B | FUEL UNIT: SUNTEC |
| | 1 | 8046448-13C | FUEL SOLENOID |
| 14 | 1 | 8046448-14 | ELBOW (USE WITH 13A) |
| 15 | 1 | 8046448-15 | GUN ASSEMBLY |
| 16 | 1 | 8046448-16 | AIR TUBE/FLANGE ASM |
| 17 | 1 | 8046448-17 | AIR CONE - #3A |
| | 1 | | AIR CONE - #4A |
| 18 | 1 | 8046448-18 | GASKET |
| 19 | 1 | 8046448-19 | CONNECTOR (USE WITH 13B, 13C) |
| 20 | 1 | 8046448-20 | CAD CELL |
| 21 | 1 | 8046448-21 | CONTROL BOX |
| 22 | 1 | 8046448-22 | TIMER, DROP OUT |
| 23 | 1 | 8046448-23 | COVER, CONTROL BOX |
| 24 | 1 | 8046448-24 | ADAPTOR, NOZZLE SUPPORT |
| 25 | 1 | 8046448-25 | ELECTRODE SUPPORT ASM |
| 26 | 1 | 8046448-26 | ELECTRODE (RH) |
| 27 | 1 | 8046448-27 | ELECTRODE (LH) |
| 28 | 1 | 8046448-28 | OIL PIPE/FITTING |
| 29 | 1 | 8046448-29 | DISC/BAFFLE PLATE |
| 30 | 1 | 8046448-30 | CAST STABILIZER |
| | 1 | | STAMPED STABILIZER |

| Suggested Combustion Chamber Dimensions Conversion or Upgrading Chamber Dimensions (In Inches) | | | | | |
|--|--------|--------|-------|--------|-----------------|
| Firing Rate (G.H.P) | Square | | Round | Height | Floor to Nozzle |
| | Width | Length | | | |
| 0.85 | 8.5 | 8.5 | 8.5 | 8.5 | 8.5 |
| 1.00 | 9 | 9 | 10½ | 12½ | 5-6 |
| 1.25 | 10 | 10 | 11¼ | 12½ | 5-6 |
| 1.35 | 10½ | 10½ | 11¼ | 12¾ | 5-6 |
| 1.50 | 11 | 11 | 12¾ | 13 | 5-6 |
| 1.65 | 11½ | 11½ | 13 | 13¼ | 5-6 |
| 2.00 | 12¾ | 12¾ | 14¼ | 13½ | 6-7 |
| 2.50 | 14¼ | 14¼ | 16 | 14 | 7-8 |
| 3.00 | 15½ | 15½ | 17½ | 15 | 7-8 |

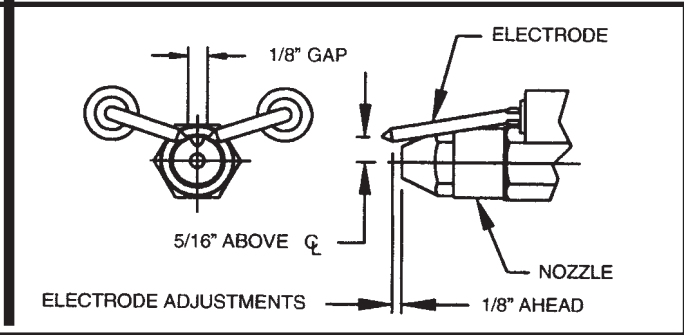
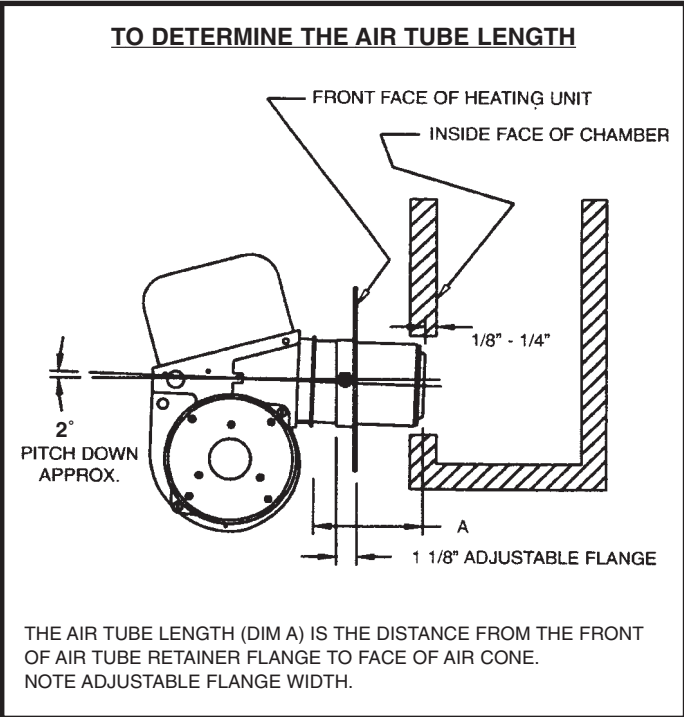



WAYNE COMBUSTION SYSTEMS

801 GLASGOW AVE.
FORT WAYNE, IN 48803

LIMITED WARRANTIES FOR OIL AND GAS BURNERS, MADE BY WAYNE AND USED IN RESIDENTIAL INSTALLATIONS

WAYNE COMBUSTION SYSTEMS ("WAYNE") warrants to those who purchase its **Oil Burner Models** for resale or for incorporation into a product of resale, that its burner is free from defects in material and workmanship under normal use and service for thirty-six (36) months from the date of manufacture. **ALL GAS BURNERS** manufactured by "WAYNE" will be similarly warranted for eighteen(18) months from date of manufacture except where original manufacture offers a greater warranty. (Reference #6 below) THESE LIMITED WARRANTIES DO NOT APPLY UNLESS THE BURNER COVERED BY IT IS PROPERLY INSTALLED BY A QUALIFIED, COMPETENT TECHNICIAN, WHO IS LICENSED WHERE STATE AND/OR LOCAL CODES PREVAIL, AND WHO IS EXPERIENCED IN MAKING SUCH INSTALLATIONS, IN ACCORDANCE WITH NFPA #31 OF THE NATIONAL FIRE PROTECTION ASSOCIATION AND IN ACCORDANCE WITH ALL LOCAL, STATE AND NATIONAL CODES.

Any **IN-WARRANTY** burner component which is defective in material or workmanship will be either repaired or replaced as follows:

1. Fuel units, motors, transformers, gas valves, and controls should be returned to an authorized service station or distributor of WAYNE for determination of applicability of this LIMITED WARRANTY as to either repair or replacement, where said service station or distributor is reasonably available in the customer's locality. The manufacturers of burner components regularly publish and distribute listings showing the locations of their network of service stations. Where such local service is NOT available for the burner components described above or other burner parts are involved, these items should be returned, freight prepaid, to WAYNE Service Department, 801 Glasgow Ave, Fort Wayne, Indiana 46803.
2. Burners and/or component(s) determined to be covered under this LIMITED WARRANTY by WAYNE shall be repaired or replaced at WAYNE's sole option.
3. WAYNE is not responsible for any labor cost for the removal and replacement of said burner or burner components and equipment associated therewith.
4. A burner so repaired will then carry the LIMITED WARRANTY equal to the unexpired portion of the original burner LIMITED WARRANTY.
5. If inspection by WAYNE does **NOT** disclose any defect covered by this LIMITED WARRANTY, the burner or burner component(s) will be either repaired or replaced at the expense of the customer and WAYNE's regular charges will apply.
6. If the original manufacturer of a burner component offers a warranty greater than either of our LIMITED WARRANTIES described above, then this portion will be added to our LIMITED WARRANTY.

This LIMITED WARRANTY does **NOT** cover products which have been damaged as the result of accident, abuse, misuse, neglect, improper installations, improper maintenance or failure to operate in accordance with WAYNE's written instructions.

These LIMITED WARRANTIES do not extend to anyone except the first purchaser at retail and only when the burner is in the original installation site.

IMPLIED WARRANTIES OF MERCHANTABILITY AND FITNESS FOR A PARTICULAR PURPOSE SHALL BE LIMITED TO THE DURATION OF THE LIMITED EXPRESS WARRANTIES CONTAINED HEREIN. WAYNE EXPRESSLY DISCLAIMS AND EXCLUDES ANY LIABILITY FOR CONSEQUENTIAL OR INCIDENTAL DAMAGES OF ANY NATURE FOR BREACH OF ANY EXPRESS OR IMPLIED WARRANTY.

Some states do not allow limitation on how long an implied warranty lasts, so the above limitation may not apply to you. Also, some states do not allow the exclusion or limitation of incidental or consequential damages, so the above limitation or exclusion may not apply to you. WAYNE neither assumes or authorizes any person to assume for WAYNE any other liability or obligation in connection with the sale of these products. This warranty gives you specific legal rights, and you may also have other rights which vary from state to state.

WARRANTY RETURN GOODS POLICY

LIMITED WARRANTY

The Manufacturer warrants its products to be free from defects in material and workmanship for a period of twelve months from the date of shipment from the factory. The Manufacturer shall not be responsible for any damage resulting to or caused by its products by reason of installation, improper storage, unauthorized service, alteration of the products, neglect or abuse, or use of the product in a manner inconsistent with its design. The warranty does not extend to any component parts not manufactured by Manufacturer; however, Manufacturer's warranty herein shall not limit any warranties made by manufacturers of component parts which extend to Buyer.

Claims for defects in material and workmanship shall be made in writing to Manufacturer within ten days of discovery of defect. Manufacturer may either send a service representative or have the product returned to its factory at Buyer's expense for inspection. Upon notification of defect, Manufacturer will issue a return goods authorization number to Buyer. The return goods authorization number must accompany the product returned. If judged by the Manufacturer to be defective in material or workmanship, the product will be replaced or repaired at the option of the Manufacturer, free from all charges except authorized transportation. Buyer shall be responsible for all maintenance services consisting of lubrication and cleaning of equipment, replacing expandable parts, making minor adjustments, and performing operating checks, all in accordance with procedures outlined in Manufacturer's maintenance literature.

THE FOREGOING WARRANTY IS IN LIEU OF ALL OTHER WARRANTIES AND NO REPRESENTATIONS, GUARANTEES, OR WARRANTIES, EXPRESS OR IMPLIED, (INCLUDING BUT NOT LIMITED TO A WARRANTY OF MERCHANTABILITY OR FITNESS FOR A PARTICULAR PURPOSE), ARE MADE BY THE MANUFACTURER IN CONNECTION WITH THE MANUFACTURE OR SALE OF ITS PRODUCTS. NO EMPLOYEE, DISTRIBUTOR, OR REPRESENTATIVE IS AUTHORIZED TO CHANGE THIS WARRANTY ON BEHALF OF MANUFACTURER.

THE REMEDIES OF BUYER SET FORTH HEREIN ARE EXCLUSIVE AND ARE IN LIEU OF ALL OTHER REMEDIES. THE LIABILITY OF MANUFACTURER WHETHER IN CONTRACT, TORT, UNDER ANY WARRANTY, OR

OTHERWISE SHALL NOT EXTEND BEYOND ITS OBLIGATION TO REPAIR OR REPLACE, AT ITS OPTION ANY PRODUCT OR PART FOUND BY MANUFACTURER TO BE DEFECTIVE IN MATERIAL OR WORKMANSHIP. MANUFACTURER SHALL NOT BE LIABLE FOR COST OF INSTALLATION AND/OR REMOVAL OR BE RESPONSIBLE FOR DIRECT, INDIRECT, SPECIAL OR CONSEQUENTIAL DAMAGES OF ANY NATURE.

GENERAL RETURNS OF MERCHANDISE

1. All returns must be pre-authorized
 - A. Please call our parts department for an RGA number
 - B. Please include RGA number on the outside of box
 - C. Include any required paper work or special instructions
 - D. Items returned without an RGA number will not be accepted
2. All returns are subject to a 20% restock charge.
3. Special items are non-returnable
 - A. Non-stock parts
 - B. Custom parts
 - C. If you are unsure about a parts status when ordering, ask your McLaughlin representative if the item fits on of the above conditions.
4. Items must be returned within thirty days of original order date.
5. Items not returned within 30 days from the date of RGA is issued will not be accepted.
6. The item(s) must be in new condition. Used item(s) are not returnable.

