



McLaughlin[®]

2006 Perimeter Road. Greenville, SC 29605
Toll Free: 800/435-9340 - Phone: 864/277-5870
Fax: 864/235-9661 - Website address: www.mightymole.com
Email address: mmole@mightymole.com

**Parts Manual
V250 Vacuum Skid
Part #E850605
(Serial # 250D061107868 - Present)**

© 2007 by McLaughlin Group, Inc.

061207

All rights reserved. No part of this manual may be reproduced in any form, or by any means without prior written permission of McLaughlin Group, Inc.

Tank and Door Assembly

V250

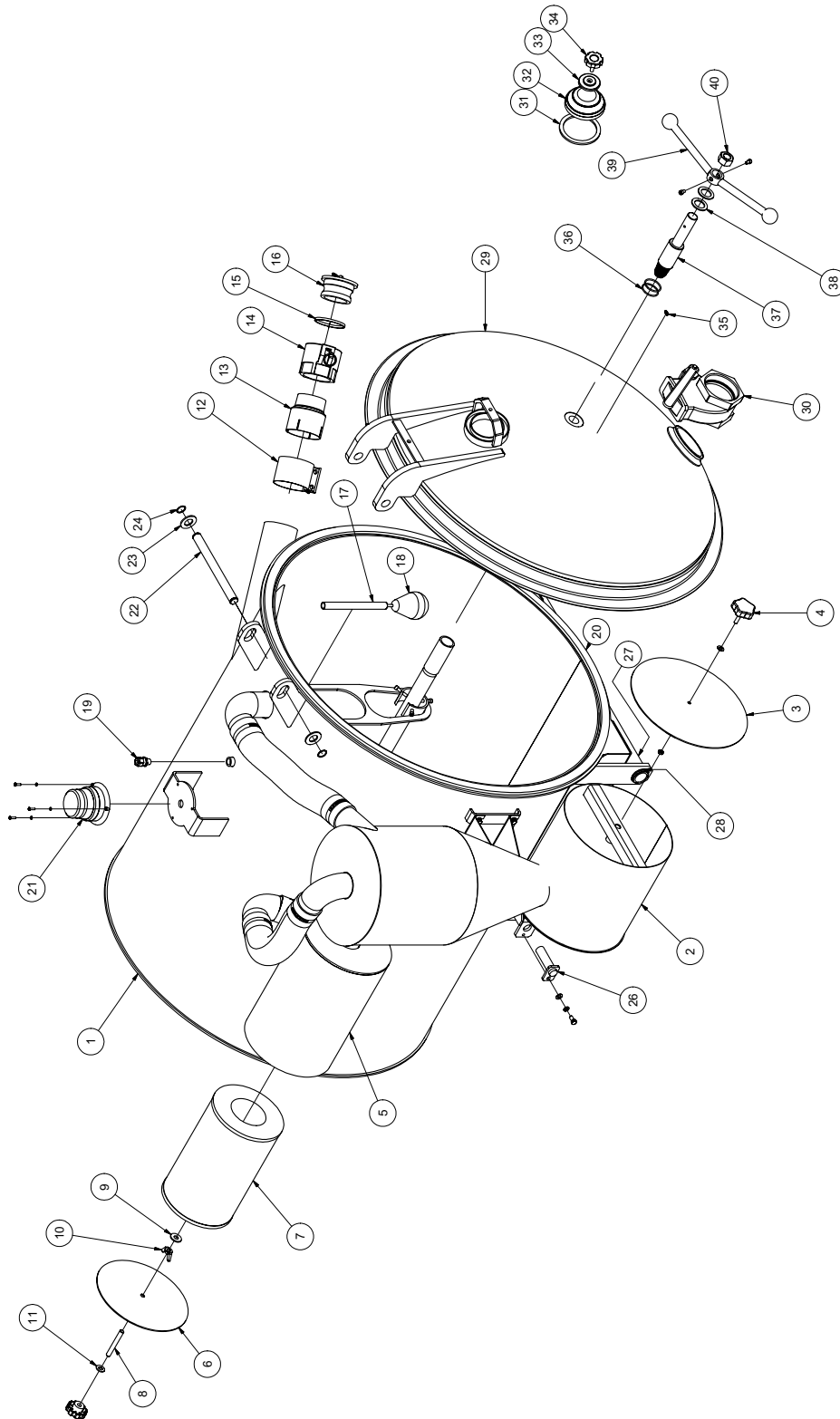

121906

VACASSY001

Tank and Door Assembly

ITEM	QTY	NUMBER	DESCRIPTION	ITEM	QTY	NUMBER	DESCRIPTION
1	1	8040602	TANK	24	2	8030362	1" SNAP RING
2	1	8040313	CYCLONE SEPARATOR HOUSING	25	2	8040633	HYDRAULIC CYLINDER
	4	U000420	SCREW, HC 3/8-16 X 1.00	4	T401270	ELBOW,90 8MB-6MJ	
	4	U200600	WASHER, FLAT 3/8"	1	8041439	HOSE ASSY VAC 6-22 90-90	
3	1	8040315	CYCLONE SEPARATOR DOOR	1	8041440	HOSE ASSY VAC 6-37 90-90	
	1	8041444	CYCLONE DOOR GASKET	1	8041441	HOSE ASSY VAC 6-49 ST-90	
4	1	8041197	MALE THREADED KNOB 3/8-16	1	8041442	HOSE ASSY VAC 6-63 ST-90	
	1	8041231	BONDED SEALING WASHER 3/8"	26	4	8040753	CYLINDER PIN
	1	U210061	NUT, LOCK 3/8-16	4	U000400	SCREW, HC 3/8-16 X 0.75	
5	1	8040326	AIR FILTER HOUSING	4	U210060	WASHER, LOCK 3/8"	
	4	U000420	SCREW, HC 3/8-16 X 1.00	27	1	8040872	SPLIT PIVOT TUBE
	4	U200600	WASHER, FLAT 3/8"	1	8040870	SPLIT PIVOT TUBE SHANK	
6	1	8040043	AIR FILTER HOUSING DOOR	2	8040871	SPLIT PIVOT TUBE PIN	
	1	8041357	AIR FILTER DOOR GASKET	28	2	8030363	2" SPIRAL SNAP RING
	1	8041218	FEMALE THREADED KNOB 1/2-13	29	1	8041069	DOOR
7	1	8031178	AIR FILTER ELEMENT	30	1	8030916	GATE VALVE
8	1	8040302	THREADED ROD	1	8030431	4" CLOSE NIPPLE	
9	1	U200100	WASHER, FLAT 1/2"	31	1	8032007	4" COUPLER GASKET
10	1	8041219	NUT, WING 1/2-13 3" WIDE	32	1	8031048	SIGHT GLASS
11	1	8041232	BONDED SEALING WASHER	33	1	8031047	SIGHT GLASS PLATE
12	1	8030400	4" BAND CLAMP	34	1	8031046	SIGHT GLASS HAND WHEEL
13	1	8031044	3" SUCTION PORT ADAPTER	35	1	T500080	FITTING, GREASE 3/16"
14	1	8030392	3" FEMALE COUPLER	36	2	W200120	ORING #225 BUNA
15	1	8031042	3" COUPLER GASKET	37	1	8040306	DOOR STRIKER
16	1	8030393	3" COUPLING PLUG	38	3	8030174	SPACER
	1	8041485	LANYARD CABLE	39	1	8040235	DOOR HANDLE
17	1	8040769	HIGH LEVEL FLOAT SWITCH TUBE	2	U010040	SCREW, HSH 5/16-18 X 0.50	
18	1	8030531	HIGH LEVEL FLOAT SWITCH	4	J400060	KNOB	
	1	8041291	RUBBER BUSHING	40	1	U120060	LOCKNUT, NYLON 1" - 8
19	1	X000113	STRAIN RELIEF, 1/2"	*	1	8041438	HOSE VAC KANAFLEX 3-19
20	1	8041765	DOOR SEAL	*	1	8041437	HOSE VAC KANAFLEX 3-36
21	1	8030347	STROBE LIGHT	*	1	8041436	HOSE VAC KANAFLEX 3-88
	3	U010006	SCREW, PHILLIPS #10-24 X 1"	*	2	8030369	NOZZLES
	3	U210005	WASHER, LOCK #10	*	1	8041460	CABLE VAC SO3-192
	3	U100010	NUT, HEX #10-24	*	1	8041839	DOOR SEAL GLUE
22	1	8040058	DOOR HINGE ROD				
23	2	U200171	DOOR HINGE WASHER				

* NOT SHOWN

Power Pack Assembly

V250

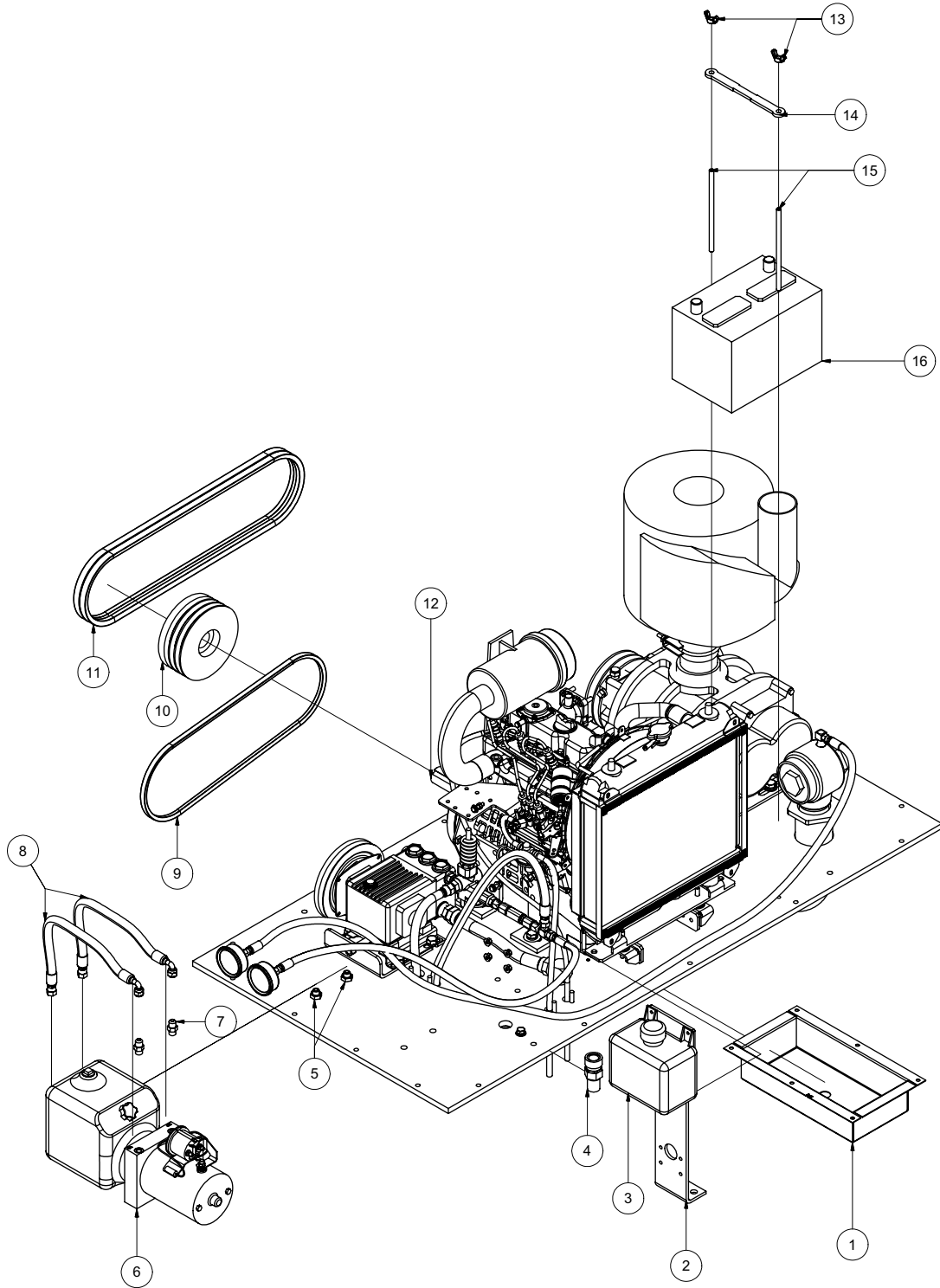

VACASSY101

Power Pack Assembly

ITEM	QTY	NUMBER	DESCRIPTION
1	1	8040722	DRIP PAN
	6	U000400	SCREW, HC 1/4"- 20 X 3/4"
	6	U210020	WASHER, LOCK 1/4"
	6	U200020	WASHER, FLAT 1/4"
2	1	8040577	WATER REGULATOR/ OVERFLOW BRACKET
	2	U000817	SCREW, HC 1/2"-13 X 1"
	2	U210100	WASHER, LOCK 1/2"
	2	U200100	WASHER, FLAT 1/2"
3	1	8040645	TANK, OVERFLOW COOLANT
	3	U000040	SCREW, HC 1/4"-20 X 3/4"
	6	U200020	WASHER,FLAT 1/4"
	3	U210020	WASHER, LOCK 1/4"
	3	U100020	NUT, HEX 1/4"-20
4	1	X000112	CONNECTOR, PANEL 3/4 MNPT-3/4FNPT
	1	X000109	STRAIN RELIEF, 3/4"
	1	X000108	3/4" COUPLING NUT
5	2	T400391	BULKHEAD 6MP 6MP
6	1	8040486	HYDRAULIC POWER PACK, 12V (KTI)
	2	U000420	SCREW, HC 3/8"-16 X 1"
	2	U210060	WASHER, LOCK 3/8"
	2	U200600	WASHER, FLAT 3/8"
7	2	T400037	UNION 6MB-6MJ
8	2	8040973	HOSE ASSY VAC 6-20 ST-90
9	1	8040878	BELT AX45
10	1	8040695	SHEAVE 6.55" OD SD 3-GROOVE
	1	8040696	BUSHING 1 1/8" SD
	1	U410090	KEY 1/4" X 1/4" X 2 1/2"
11	2	8041027	BELT BX54
12	1	8040748	KUBOTA DH902
	1	8040748-1	MUFFLER
	4	U000820	SCREW, HC 1/2"-13 X 1 1/4"
	4	U210100	WASHER, LOCK 1/2"
	4	U200100	WASHER,FLAT 1/2"
	1	8041335	KUBOTA AIR FILTER ELEMENT
	1	8041334	KUBOTA OIL FILTER
13	2	U130040	NUT, WING 3/8"-16
14	1	8050016	BATTERY HOLD DOWN
15	2	8040684	ROD, BATTERY HOLD DOWN
16	1	X400050	BATTERY, 31-MHD WORKAHOLIC
	2	X300218	CABLE BATTERY 711431 18"
*	4	8031392	ISOLATOR
*	4	U000560	SCREW, HC 3/8"-16 X 3"
*	4	8030389	WASHER, SNUBBING
*	4	U210060	WASHER, LOCK 3/8"
*	4	U100060	NUT, HEX 3/8-16
*	8	U000420	SCREW, HC 3/8"-16 X 1"
*	16	U200060	WASHER,FLAT 3/8"
*	8	U210060	WASHER,LOCK 3/8"
*	8	U100060	NUT,HEX 3/8-16
*	2	8041517	HOSE VAC FUEL 5/16-36

* ITEM NOT SHOWN

VACASSY101

Blower Assembly

V250

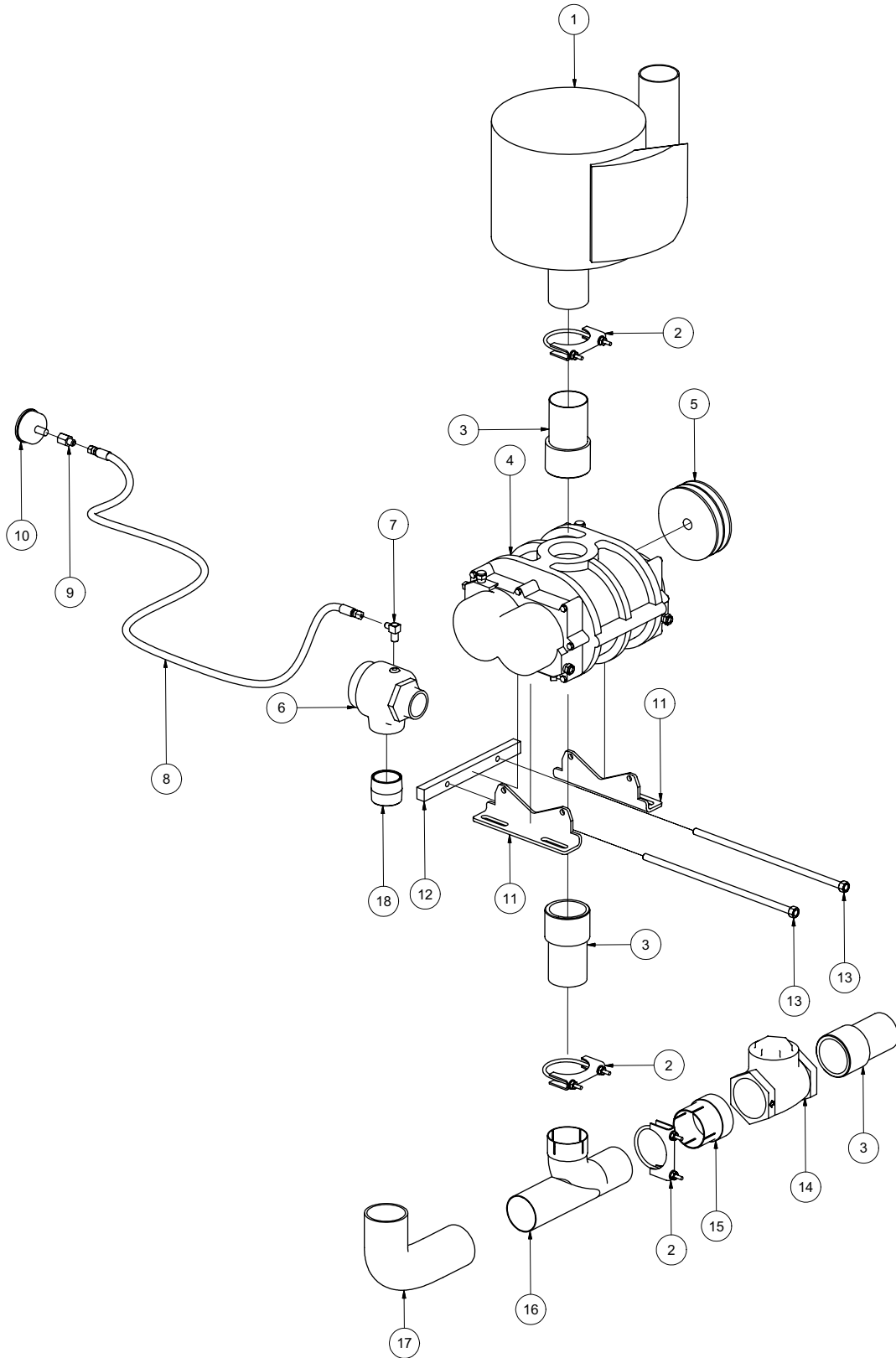

VACASSY201

Blower Assembly

ITEM	QTY	NUMBER	DESCRIPTION
1	1	8030332	SILENCER, 575 CFM, COWL
2	3	8030395	3" U-BOLT CLAMP
3	3	8030287	3" HOSE X 3" MNPT ADAPTER
4	1	8041250	BLOWER (MODEL 47)
	4	U000817	SCREW, HC 1/2"-13 X 1"
	4	U210100	WASHER, LOCK 1/2"
	4	U200100	WASHER, FLAT 1/2"
5	1	8040697	SHEAVE 6.55 DIA 2 GROOVE
	1	8040642	BUSHING 7/8" SDS
	1	U410042	KEY 3/16" X 3/16" X 2"
6	1	8030337	KUNKLE VALVE, 575 CFM
7	1	T401100	ELBOW 4MP 4MJ 90
8	1	8040970	HOSE ASSY VAC 4-70 ST-ST
9	1	8030483	UNION, 4FP 4MJ
10	1	8030371	HYD PRESSURE GAUGE
11	2	8040559	BLOWER FOOT (MODEL 47)
12	1	8040702	TENSION BLOCK 575 CFM
13	2	8040751	BLOWER TENSIONER ROD
14	1	8040799	CHECK VALVE 3" FNPT
15	1	8040788	EXHAUST ADAPTER 3"MNPT - 3"ID
16	1	8041033	HEADER INLET-BLOWER WELD'T
17	1	8040984	3" INLET HEADER HOSE
18	1	8043157	2" X 8" PIPE NIPPLE

Water Pump Assembly

V250

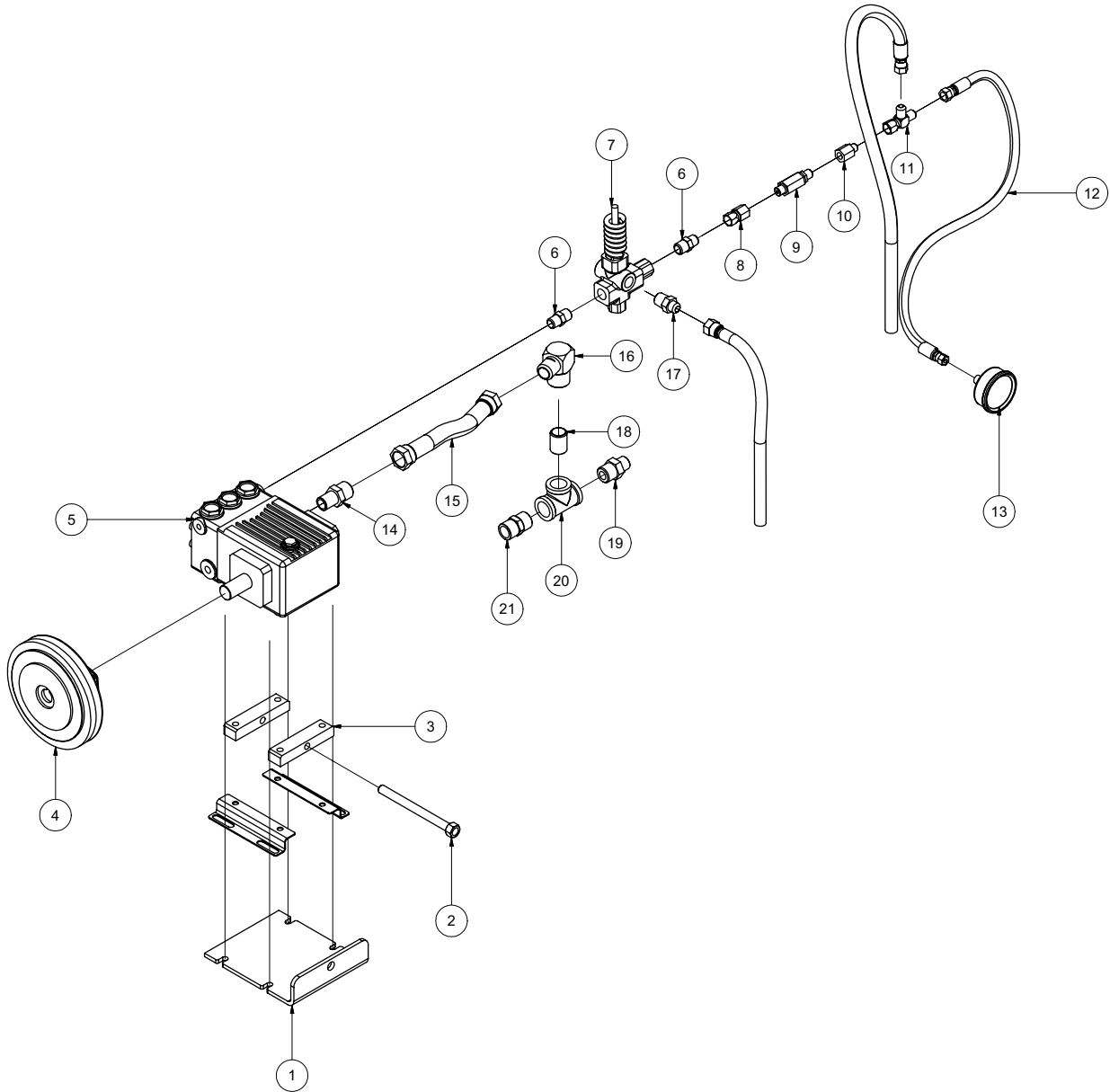

VACASSY301

Water Pump Assembly

ITEM	QTY	NUMBER	DESCRIPTION
1	1	8040746	WATER PUMP TENSIONER PLATE
	4	U000420	SCREW, HC 3/8"-16 X 1"
	4	U210060	WASHER, LOCK 3/8"
	4	U200600	WASHER, FLAT 3/8"
2	1	8030020	WATER PUMP TENSIONER ROD
3	2	8040219	WATER PUMP TENSIONER BLOCK
4	1	8040176	WATER PUMP CLUTCH
5	1	8040834	WATER PUMP (TX1510)
	4	U001605	SCREW, HC 8MM X 1.25 X 40
	4	U210055	WASHER, LOCK M8
	1	U410094	KEY 5/16" X 5/16" X 1 3/8"
6	2	T400805	UNION, 8MP 6MP
7	1	8030341	UNLOADER VALVE
8	1	8031125	UNION, 6FJ 4FP
9	1	8030923	HIGH PRESSURE WATER FILTER
10	1	8031126	UNION, 4FP 6MJ
11	1	T402153	TEE, 6MJ 6MJ 6FJ
12	1	8041152	HOSE ASSY VAC 6-30 ST-ST
13	1	8030372	WATER PRESSURE GAUGE 1/4NPT
14	1	T400070	UNION, 8MP 12MJ
15	1	8041863	HOSE VAC PUSH 12-9
	2	8030525	FITTING, HOSE #12FJ PUSH LOCK
16	1	T401180	ELBOW, 12MP 12MJ
17	1	T400040	UNION, 8MP 8MJ
18	1	T421020	NIPPLE, PIPE 12MP 12MP
19	1	T404030	UNION, 12MP 8MP
20	1	T402160	TEE 12FP 12FP 12FP
21	1	T400100	UNION, 12MP 12MJ

VACASSY301

Enclosure Assembly

V250

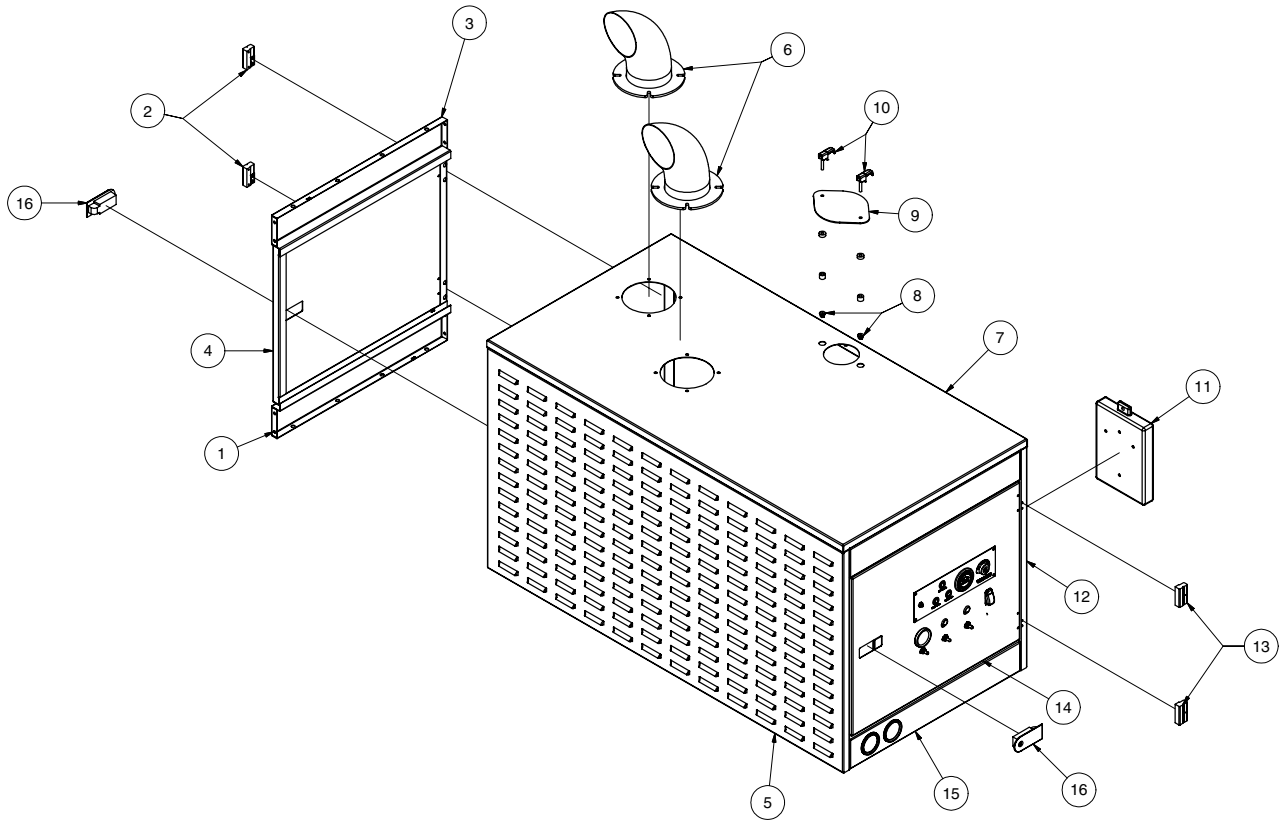

VACASSY401

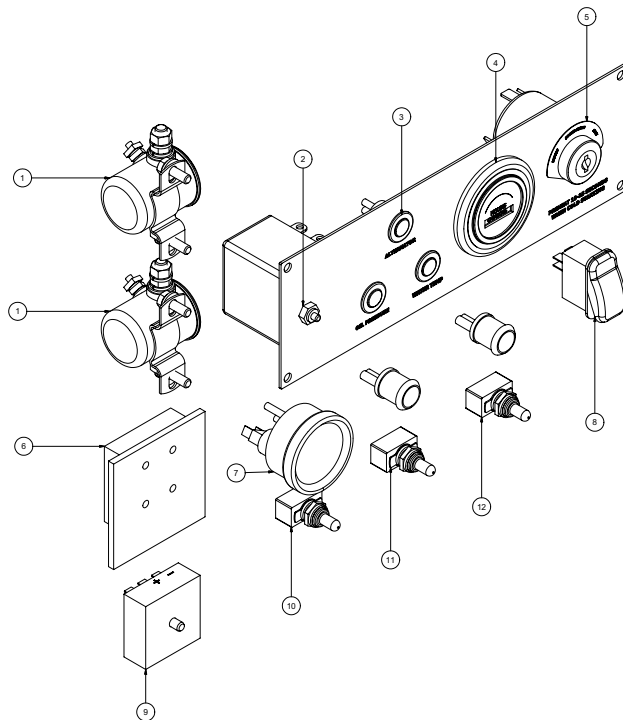

VACASSY502

Enclosure Assembly

V250

ITEM	QTY	NUMBER	DESCRIPTION
1	1	8041112	SIDE PANEL
2	2	8040589	OFFSET HINGE TYPE A
	8	U030525	SCREW, PAN HD #10-32X1/2
3	2	8040718	UPPER SIDE PANEL
4	1	8040713	DOOR
5	1	8041108	BACK SHEET
6	2	8041195	EXHAUST WELDMENT
7	1	8040719	TOP SHEET
8	2	U120142	NUT, FLANGED LOCK 1/4-20
9	1	8040592	RADIATER ACCESS PLATE
10	2	8040334	LATCH, SWELL
11	1	8030689	MANUAL BOX
12	1	8041107	FRONT SHEET
13	2	8040588	OFFSET HINGE TYPE B
	8	U030525	SCREW, PAN HD #10-32X1/2
14	1	8040743	DOOR, CONTROL
15	1	8041109	SIDE PANEL W/ GAUGES
16	2	8040586	LATCH, LEVER LOCKABLE
	1	8041816	KEY DOOR SOUTHCO LATCH
*	72	U000060	SCREW, HC 1/4-20X1
*	126	U200020	WASHER, FLAT 1/4
*	72	U210020	WASHER, LOCK 1/4
*	54	U100020	NUT, HEX 1/4-20
*	4	8041512	HORIZONTAL ENCLOSURE DOOR SEAL
*	4	8041513	VERTICAL ENCLOSURE DOOR SEAL
*	1	8031208	PLUG, POLY 2 1/2"

* ITEM NOT SHOWN

VACASSY401

ITEM	QTY	NUMBER	DESCRIPTION
1	2	8030443	80-12V SOLENOID
2	1	8030455	MURPHY SWITCH
3	5	8030457	PANEL LIGHTS
4	1	8030456	HOUR METER
5	1	8030458	KEY SWITCH
	1	8030829	KEYS
6	1	8031257	FUSE PANEL 8 POS.
	1	8030468	10 AMP FUSE
	6	8030461	5 AMP FUSE
7	1	8030330	FUEL GAUGE
8	1	X000021	ROCKER SWITCH THROTTLE HIGH/LOW
9	1	8031231	SWITCH, DELAY RELAY
10	1	8041077	SWITCH, TANK RAISE/LOWER
11	1	X000095	SWITCH, FULL TANK OVERRIDE
12	1	X000095	SWITCH, WATER PUMP CLUTCH
*	1	8030826	INLINE 20 AMP FUSE
*	1	8041268	ANTIFREEZE SWITCH

* ITEM NOT SHOWN

VACASSY502

Water Tank Assembly

125 GAL

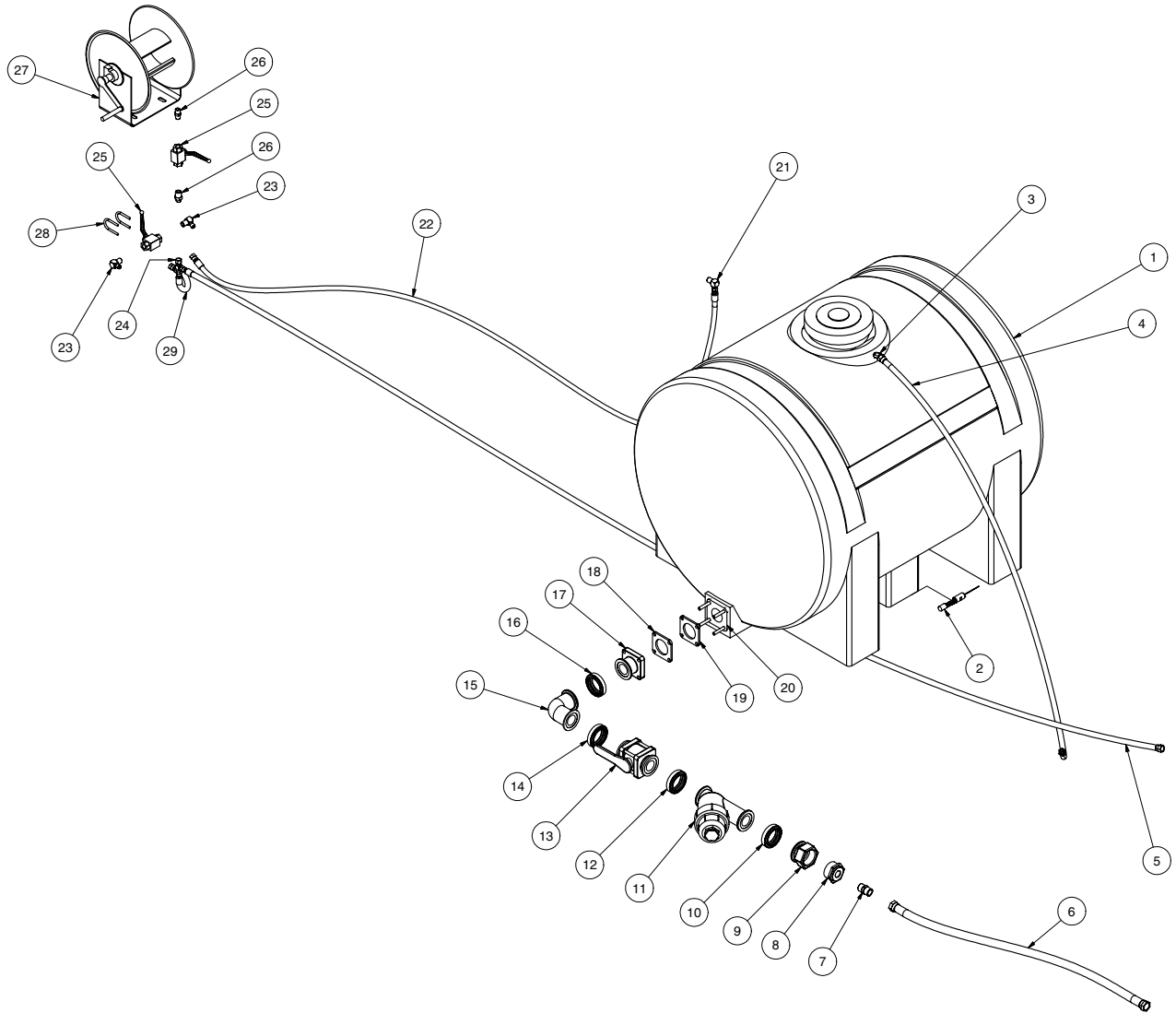

VACASSY607

Water Tank Assembly

125 GAL

ITEM	QTY	NUMBER	DESCRIPTION
1	1	8031327	125 GALLON WATER TANK
	2	8041535	WATER TANK STRAP
	1	8030931	WATER TANK LID
2	1	8030343	LOW WATER LEVEL SWITCH
3	1	8030518	BULKHEAD 45 DEG, 8MJ
4	1	8041465	HOSE VAC PUSH 8-66
	2	8030524	PUSH LOCK HOSE FITTING 8FJ
5	1	8041466	HOSE ASSY VAC 8-160 ST-ST
6	1	8041467	HOSE VAC PUSH 12-36
	2	8030524	PUSH LOCK HOSE FITTING 12FJ
7	1	T400100	UNION, 3/4MP - 12MJ
8	1	8031134	BUSHING, 2" X 3/4" NPT BANJO
9	1	8030996	ADAPTER, FEMALE 2" BANJO
10	1	8031000	CLAMP, WATER MANIFOLD
11	1	8031001	Y-STRAINER, 2" BANJO
12	1	8031000	CLAMP, WATER MANIFOLD
13	1	8030998	BALL VALVE, 1-1/2 ID BANJO
14	1	8031000	CLAMP, WATER MANIFOLD
15	1	8030995	ELBOW, 2" BANJO
16	1	8031000	CLAMP, WATER MANIFOLD
17	1	80309971	FLANGE, 2" BANJO
18	1	80309972	FLANGE GASKET, 2" BANJO
19	1	80309972	FLANGE GASKET, 2" BANJO
20	1	80309973	FLANGE BOLTED, 2" BANJO
	4	U100060	NUT, HEX 3/8-16
	4	U210060	WASHER, LOCK 3/8
21	1	T401102	ELBOW, 6MJ - 3/8MP
22	1	8041468	HOSE ASSY VAC 8-130 ST-ST
23	2	T401102	ELBOW, 6MJ - 3/8MP
24	1	T402153	TEE, 6MJ - 6MJ - 6FJ
25	2	8030351	BALL VALVE, STEEL 3/8FJ
26	2	T400028	UNION, 6MJ - 3/8MP
27	1	8030346	HOSE REEL
	4	U000420	SCREW, HC 3/8"-16 X 1.0
	8	U200060	WASHER, FLAT 3/8"
	4	U210060	WASHER, LOCK 3/8"
	4	U100060	NUT, HEX 3/8"-16
28	2	U010017	UBOLT, 1/4 - 20 X 1-1/2
29	1	8041469	HOSE ASSY VAC 8-16 ST-ST

VACASSY607

Skid Assembly

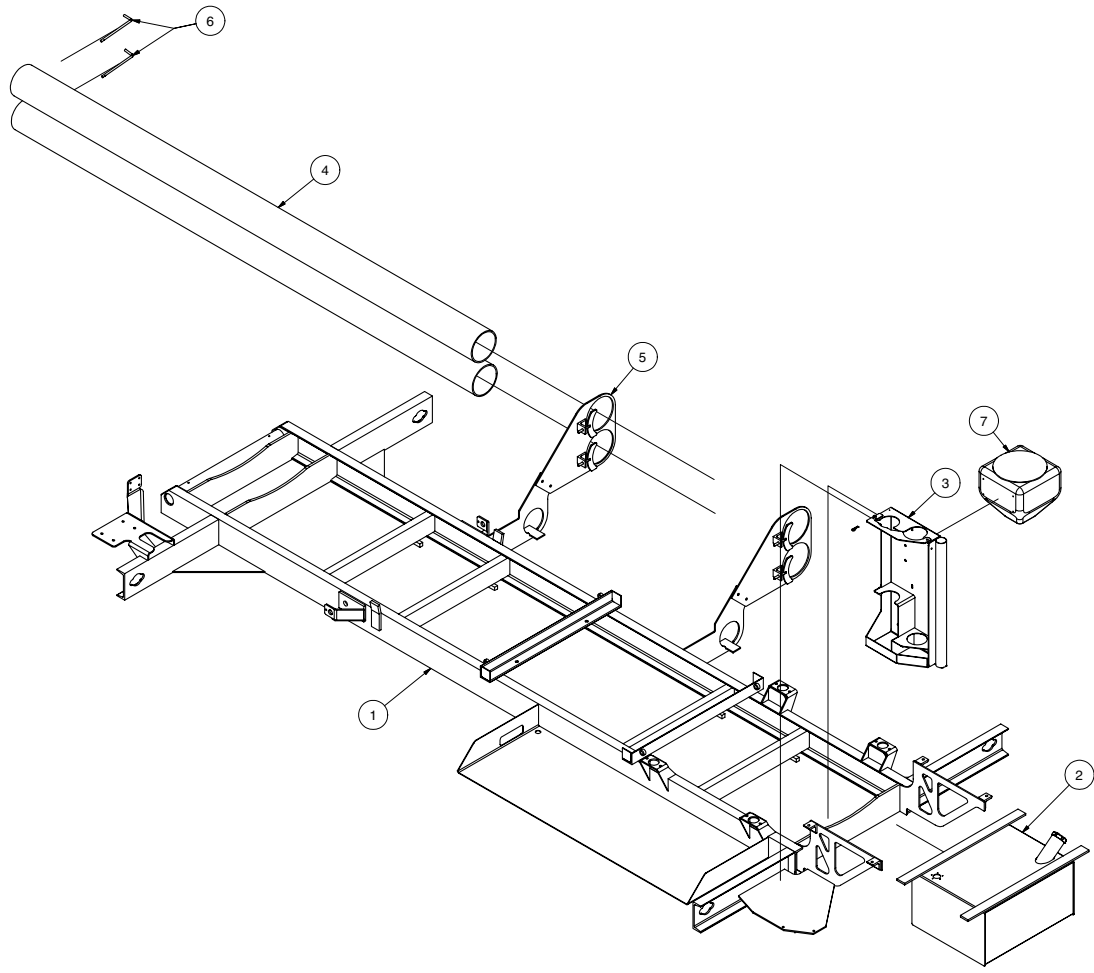

VACASSY910

Tools

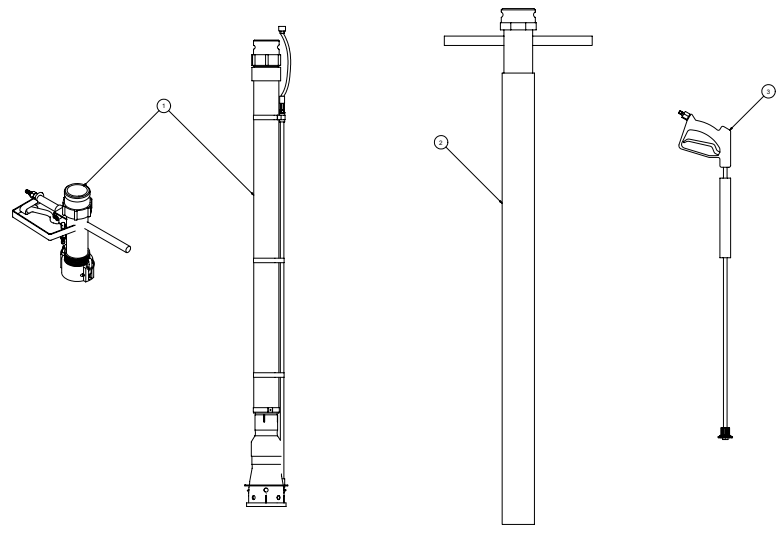

VACASSY702

Skid Assembly

ITEM	QTY	NUMBER	DESCRIPTION
1	1	8041278	SKID WELDMENT
2	1	8040763	FUEL TANK (20 GAL)
	1	36201441	FUEL CAP
	1	8030697	FUEL SENDING UNIT
	1	8030656	FUEL FILTER
3	1	8040886	TOOL RACK
	1	8040884	TOOL RACK CLOSURE
	1	R700175	R CLIP 7/8"
	1	8041259	STRAP, 10"
	1	8041485	LANYARD CABLE
4	2	8041111	HOSE STORAGE 4" X 10'
	2	8030435	END CAP 4"
	2	8030427	4" TO 6" PVC REDUCER
5	2	8041142	HOSE STORAGE BRACKETS
	4	8040979	HOSE STORAGE CLAMP
	8	U200060	WASHER, FLAT 3/8
	8	U100060	NUT, HEX 3/8
6	2	8041101	HOSE STORAGE RETAINING ROD
	2	R700175	R CLIP 7/8"
	2	8041485	LANYARD CABLE
7	1	8030394	ANTI-FREEZE TANK (4 GAL)
	4	U000180	SCREW, HC 5/16"-18 X .75"
	4	U200040	WASHER, FLAT 5/16
	4	U210040	WASHER, LOCK 5/16
	1	T403100	UNION 12FP 20MP
	1	T401040	ELBOW 90 12MP 12MP
	1	8030376	BALL VALVE 3/4" FP
	1	T400080	UNION 8MJ - 12MP
	2	8030524	# 8 FJ PUSHLOCK
	1	8041470	HOSE VAC PUSH 8-36
*	2	8041263	PLASTIC STRIP
		*	NOT SHOWN

VACASSY910

Tools

Item	Qty	Number	Description	Item	Qty	Number	Description
1	1	8030202	TOOL VAC REDUCTION STD COMPLETE	*	2	8040250	VACUUM HOSE ASSEMBLY 3" X 10'
	1	8030635	TOOL VAC HEAD ASSY 3"		1	8030179	BANJO 3" MALE
	2	8030486	QUICK DISCONNECT SS		1	8030392	BANJO 3" FEMALE
	1	8031079	BANJO 3" MALE		2	8030240	HOSE ADAPTER 3"
	1	8030392	BANJO 3" FEMALE		2	8041508	VACUUM HOSE 3" X 120"
	1	8030928	TRIGGER ASSEMBLY	*	1	8041830	HIGH PRESSURE WATER HOSE
	1	8030179	TOOL VAC REDUCTION LOWER ASSY	*	1	8030504	REDUCER 3/8"FP - 1/4"MP
	2	8030370	REDUCTION TOOL NOZZLE	*	1	8030487	Q.D. FEMALE 1/4"FP
	2	8031268	REDUCTION TOOL NOZZLE 45 DEG			*	NOT SHOWN
	1	8031079	BANJO 3" MALE				
	1	8040333	REDUCTION TOOL COLLAR				
2	1	8030215	TOOL VAC SUCTION 3" COMPLETE				
3	1	8030348	TOOL VAC SPRAY WAND COMPLETE				
	1	8030928	TRIGGER ASSEMBLY				
	1	8030847	WAND				
	1	8031308	NOZZLE				

VACASSY702

WIRING SCHEMATIC

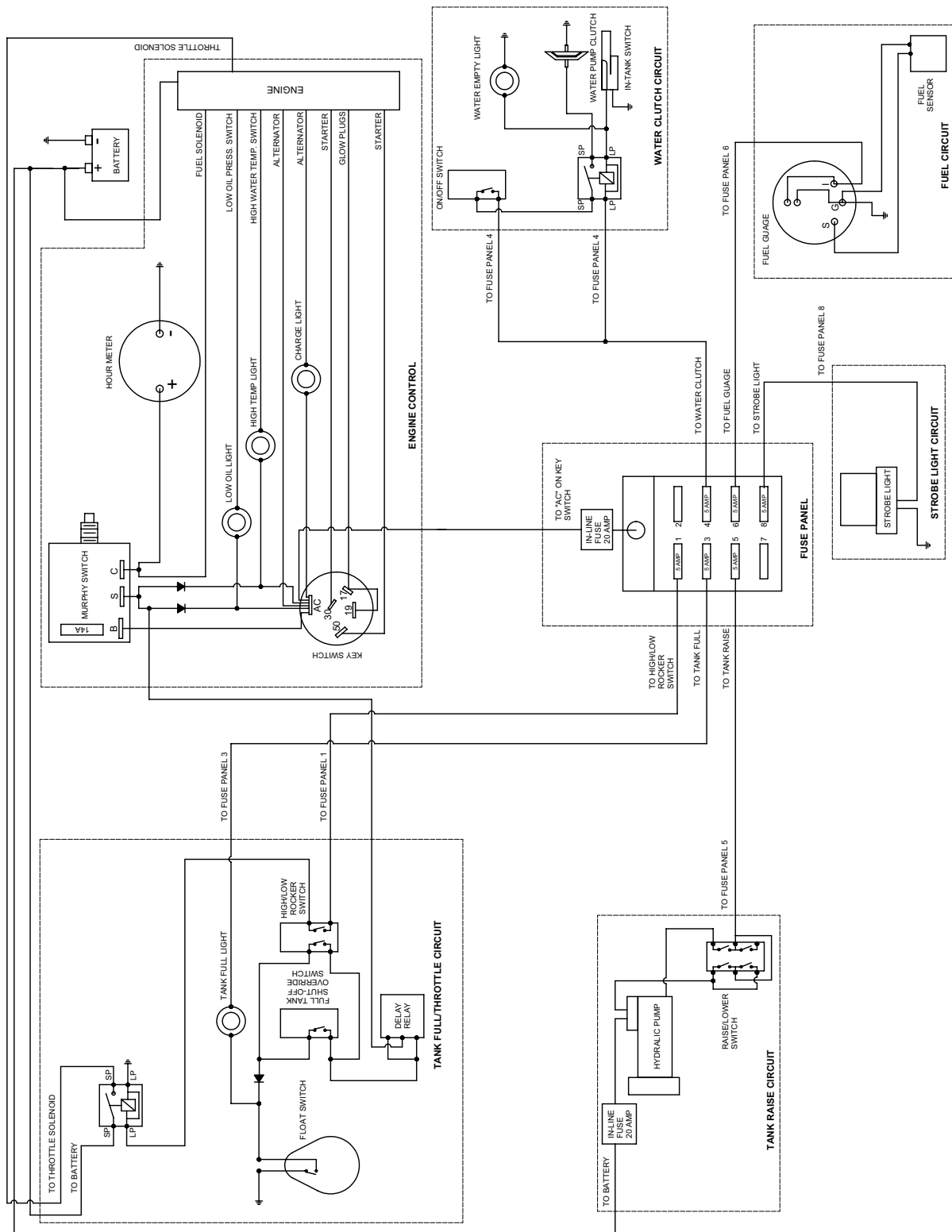

WARRANTY RETURN GOODS POLICY

LIMITED WARRANTY

The Manufacturer warrants its products to be free from defects in material and workmanship for a period of twelve months from the date of shipment from the factory. The Manufacturer shall not be responsible for any damage resulting to or caused by its products by reason of installation, improper storage, unauthorized service, alteration of the products, neglect or abuse, or use of the product in a manner inconsistent with its design. The warranty does not extend to any component parts not manufactured by Manufacturer; however, Manufacturer's warranty herein shall not limit any warranties made by manufacturers of component parts which extend to Buyer.

Claims for defects in material and workmanship shall be made in writing to Manufacturer within ten days of discovery of defect. Manufacturer may either send a service representative or have the product returned to its factory at Buyer's expense for inspection. Upon notification of defect, Manufacturer will issue a return goods authorization number to Buyer. The return goods authorization number must accompany the product returned. If judged by the Manufacturer to be defective in material or workmanship, the product will be replaced or repaired at the option of the Manufacturer, free from all charges except authorized transportation. Buyer shall be responsible for all maintenance services consisting of lubrication and cleaning of equipment, replacing expandable parts, making minor adjustments, and performing operating checks, all in accordance with procedures outlined in Manufacturer's maintenance literature.

THE FOREGOING WARRANTY IS IN LIEU OF ALL OTHER WARRANTIES AND NO REPRESENTATIONS, GUARANTEES, OR WARRANTIES, EXPRESS OR IMPLIED, (INCLUDING BUT NOT LIMITED TO A WARRANTY OF MERCHANTABILITY OR FITNESS FOR A PARTICULAR PURPOSE), ARE MADE BY THE MANUFACTURER IN CONNECTION WITH THE MANUFACTURE OR SALE OF ITS PRODUCTS. NO EMPLOYEE, DISTRIBUTOR, OR REPRESENTATIVE IS AUTHORIZED TO CHANGE THIS WARRANTY ON BEHALF OF MANUFACTURER. THE REMEDIES OF BUYER SET FORTH HEREIN ARE EXCLUSIVE AND ARE IN LIEU OF ALL OTHER REMEDIES. THE LIABILITY OF MANUFACTURER WHETHER IN CONTRACT, TORT, UNDER ANY WARRANTY, OR OTHERWISE SHALL NOT EXTEND BEYOND ITS OBLIGATION TO REPAIR OR REPLACE, AT ITS OPTION ANY PRODUCT OR PART FOUND BY MANUFACTURER TO BE DEFECTIVE IN MATERIAL OR WORKMANSHIP. MANUFACTURER SHALL NOT BE LIABLE FOR COST OF INSTALLATION AND/OR REMOVAL OR BE RESPONSIBLE FOR DIRECT, INDIRECT, SPECIAL OR CONSEQUENTIAL DAMAGES OF ANY NATURE.

GENERAL RETURNS OF MERCHANDISE

1. All returns must be pre-authorized
 - A. Please call our parts department for an RGA number
 - B. Please include RGA number on the outside of box
 - C. Include any required paper work or special instructions
 - D. Items returned without an RGA number will not be accepted
2. All returns are subject to a 20% restock charge.
3. Special items are non-returnable
 - A. Non-stock parts
 - B. Custom parts
 - C. If you are unsure about a parts status when ordering, ask your McLaughlin representative if the item fits on of the above conditions.
4. Items must be returned within thirty days of original order date.
5. Items not returned within 30 days from the date of RGA is issued will not be accepted.
6. The item(s) must be in new condition. Used item(s) are not returnable.

