



McLAUGHLIN[®]

2006 Perimeter Road. Greenville, SC 29605
Toll Free: 800/435-9340 - Phone: 864/277-5870
Fax: 864/235-9661 - Website address: www.mightymole.com
Email address: mmole@mightymole.com

**Parts Manual
Vermeer/ McLaughlin
V500/800LE Vacuum Machine
Part #E850504
(SERIAL #5LE101909396 - V5SR051110142)**

© 2010 by McLaughlin Group, Inc.

040510

All rights reserved. No part of this manual may be reproduced in any form, or by any means without prior written permission of McLaughlin Group, Inc.



Table of Contents

PARTS

SPOIL TANK AND FILTRATION

HYDRAULIC DOOR	4
HYDRAULIC DOOR CYLINDER	6
FILTRATION	10

ENGINE COMPARTMENT

ENCLOSURE	12
ENGINE	14
BLOWER	18
WATER PUMP	20
REGULATOR	26
ELECTRICAL	30
HYDRAULIC PUMP	32

WATER TANK AND ACCESSORIES

WATER TANKS - 125 GALLON SADDLE.....	36
WATER TANKS - 50 GALLON SADDLE.....	38
HOSE REEL	40

TRAILER AND SKID ASSEMBLY

TRAILER	42
SKID ASSEMBLY	44
HYDRAULIC JACK OPTION	46
SURGE BREAK OPTION	48

TOOLS

TOOL RACK	50
REDUCTION TOOL	52
VACUUM TOOL	54
WASH WAND	56
VALVE BOX CLEAN OUT TOOL	58
ROTARY LANCE	60
LAWN SWEEPER	62
SURFACE CLEANER	64

OPTIONS

BOOM	66
HOT BOX	76
ARROWBOARD	78

ELECTRICAL SCHEMATICS

VACUUM DIESEL ENGINE	80
BOOM	86
ARROWBOARD	89

HYDRAULIC SCHEMATICS

TANK AND OPTIONAL JACK	91
BOOM	93

MAINTENANCE MANUALS

ROOTS BLOWER	95
--------------------	----

WARRANTY

Tank and Door Assembly

V500LE

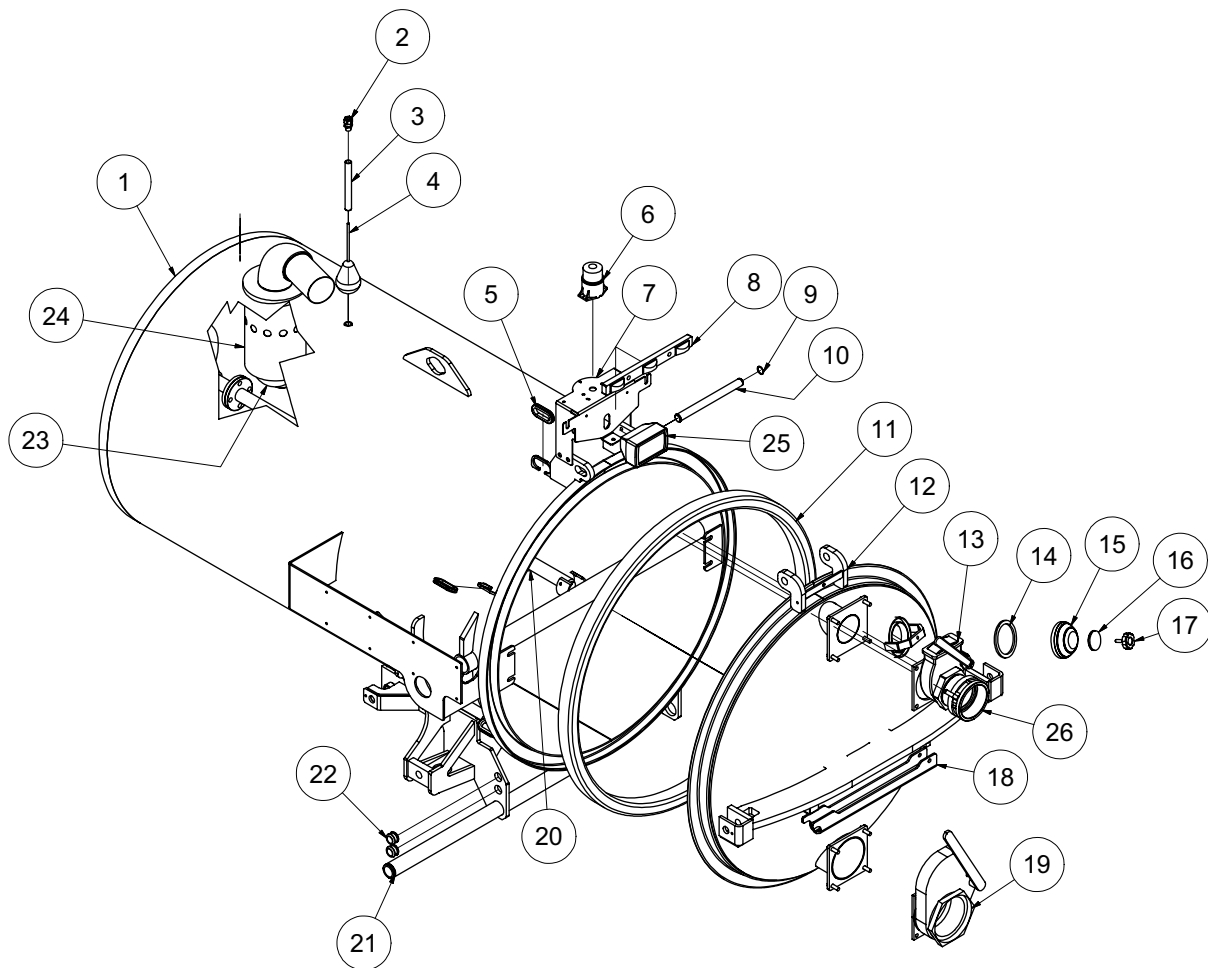

Tank and Door Assembly

V500LE

ITEM	QTY	PART NO.	DESCRIPTION
1	1	8045737	TANK WELDMENT - 500LE (42"DIA)
2	1	X000113	STRAIN RELIEF, 1/2"
3	1	8040769	HIGH LEVEL FLOAT SWITCH TUBE
	1	8041291	BUSHING, RUBBER
4	1	8030531	HIGH LEVEL FLOAT SWITCH
5	4	8042812	GROMMET 2"ID 3"OD 1/4"WOG TRAILER SLOT MODEL
6	1	8043139	STROBE LIGHT
	3	U010006	SCREW, PHILLIPS #10 - 24 X 1"
	3	U210005	WASHER, LOCK #10
	3	U100010	NUT, HEX #10 - 24
7	1	8046507	STROBE LIGHT BRACKET
	4	X000343	DT MOUNTING CLIP
	4	U000880	SCREW, HC 1/2" - 13 X 2.00"
	4	U200100	WASHER, FLAT 1/2"
	4	U210111	WASHER, LOCK 1/2"
	4	U100200	NUT, HEX 1/2" - 13
8	1	8041509	LIGHT CLEARANCE 3 BAR
9	2	8030362	1" SNAP RING
10	1	8040058	DOOR HINGE ROD
11	1	8041765	DOOR SEAL 42" DIA TANK
12	1	8045738	DOOR WELDMENT - 500 (42" DIA)
13	1	8046215	VALVE, 4" GATE BRASS LEVER FLANGE
*	1	8046231	O-RING, GATE VALVE FLANGE
14	1	8032007	GASKET, 4" COUPLER
15	1	8031048	SIGHT GLASS
16	1	8031047	SIGHT GLASS PLATE
17	1	8031046	SIGHT GLASS HAND WHEEL
18	1	8041212	TANK SAFETY BRACE
19	1	8046214	VALVE, 6" GATE BRASS LEVER FLANGE
*	1	8046231	O-RING, GATE VALVE FLANGE
20	1	8043166	500HLD TANK ROD WELDMENT
*	3	8030369	NOZZLE, TANK CLEAN OUT
*	1	W200120	O-RING 1 7/8" X 2 1/8" X 1/8" (225)
21	1	8042648	TANK PIVOT ROD
	4	U200100	WASHER, FLAT 1/2"
	2	U100120	NUT, HEX 1/2" - 13
22	4	8041686	GROMMET 1"ID - 1 1/4"DOG - 1/4"WOG
23	1	8043700	BALLFLOAT SHUTOFF WELDMENT
	2	U000420	SCREW, HC 3/8"-16 X 1.00"
	2	U210060	WASHER, LOCK 3/8"
	2	U200600	WASHER, FLAT 3/8"
24	1	8043570	BALL STRAINLESS FLOAT 6"
25	1	8043138	WORKLIGHT
26	1	8046445	CAMLOCK, 4" AL MCAM X MNPT

* NOT SHOWN

Tank and Door Assembly

V800LE

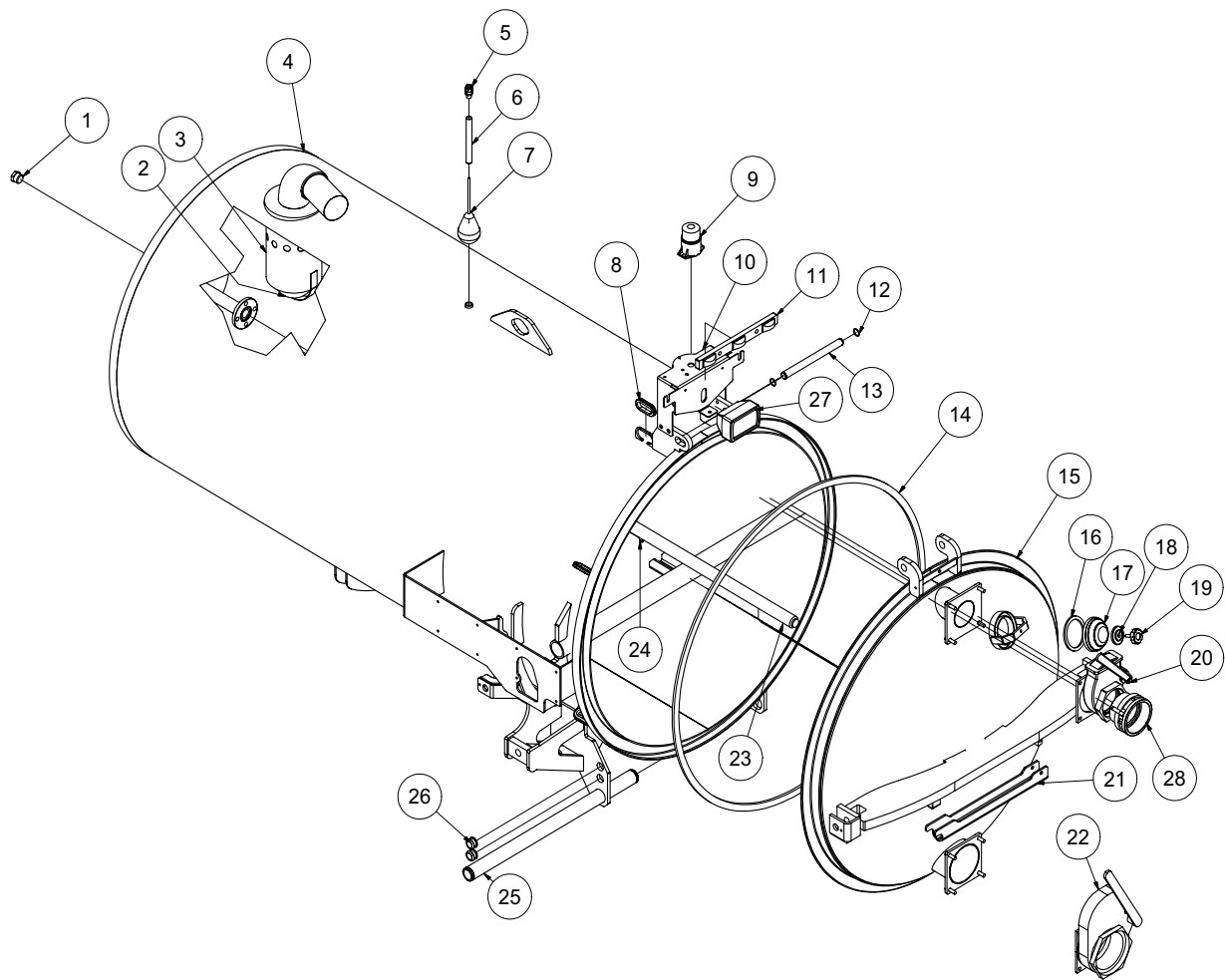

Tank and Door Assembly

V800LE

ITEM	QTY	PART NO.	DESCRIPTION
1	1	T405120	1" PLUG MB
2	1	8043570	BALL STAINLESS FLOAT 6"
3	1	8043700	BALL FLOAT SHUTOFF WELDMENT
	2	U000420	SCREW, HC 3/8"-16 X 1.00"
	2	U210060	WASHER, LOCK 3/8"
	2	U200600	WASHER, FLAT 3/8"
4	1	8046150	TANK WELDMENT - 800LE (48"DIA)
5	1	X000113	STRAIN RELIEF, 1/2"
6	1	8040769	HIGH LEVEL FLOAT SWITCH TUBE
7	1	8030531	HIGH LEVEL FLOAT SWITCH
8	4	8042812	GROMMET 2"ID3"OD1/4" WOG TRAILER SLOT MODEL
9	1	8043139	STROBE LIGHT
	3	U010006	SCREW, PHILLIPS #10-24 X 1"
	3	U210005	WASHER, FLAT 1/2"
	3	U100010	NUT HEX, #10 - 24
10	1	8046507	STROBE LIGHT BRACKET WELDMENT
	4	X000343	DT MOUNTING CLIP
	4	U000880	SCREW, HC 1/2"-13 X 2.00"
	4	U200100	WASHER, FLAT 1/2"
	4	U210111	WASHER, LOCK 1/2"
	4	U100200	NUT, HEX 1/2" - 13
11	1	8041509	LIGHT CLEARANCE 3 BAR
12	2	8030362	1" SNAP RING
13	1	8040058	DOOR HINGE ROD
14	1	8030276	DOOR SEAL, 48"DIA
15	1	8046192	DOOR 750/800 (48")- WELDMENT
16	1	8032007	GASKET, 4" COUPLER
17	1	8031048	SIGHT GLASS
18	1	8031047	SIGHT GLASS PLATE
19	1	8031046	SIGHT GLASS HAND WHEEL
20	1	8046215	4" GATE VALVE
21	1	8041212	TANK SAFETY BRACE
22	1	8046214	VALVE 6" GATE BRASS LEVER
23	1	8046172	TANK ROD 800LE WELDMENT
*	1	W200120	O-RING, 1 7/8" X 2 1/8" X 1/8" (225)
24	3	8030369	NOZZLE, TANK CLEANOUT
25	1	8042648	TANK PIVOT ROD
26	4	8041686	GROMMET 1"ID- 1 1/4"DOG - 1/4"WO
27	1	8043138	WORK LIGHT
28	1	8046444	CAMLOCK, 4" AL MCAM X MNPT

* NOT SHOWN

Hyd. Door Cylinder Assembly

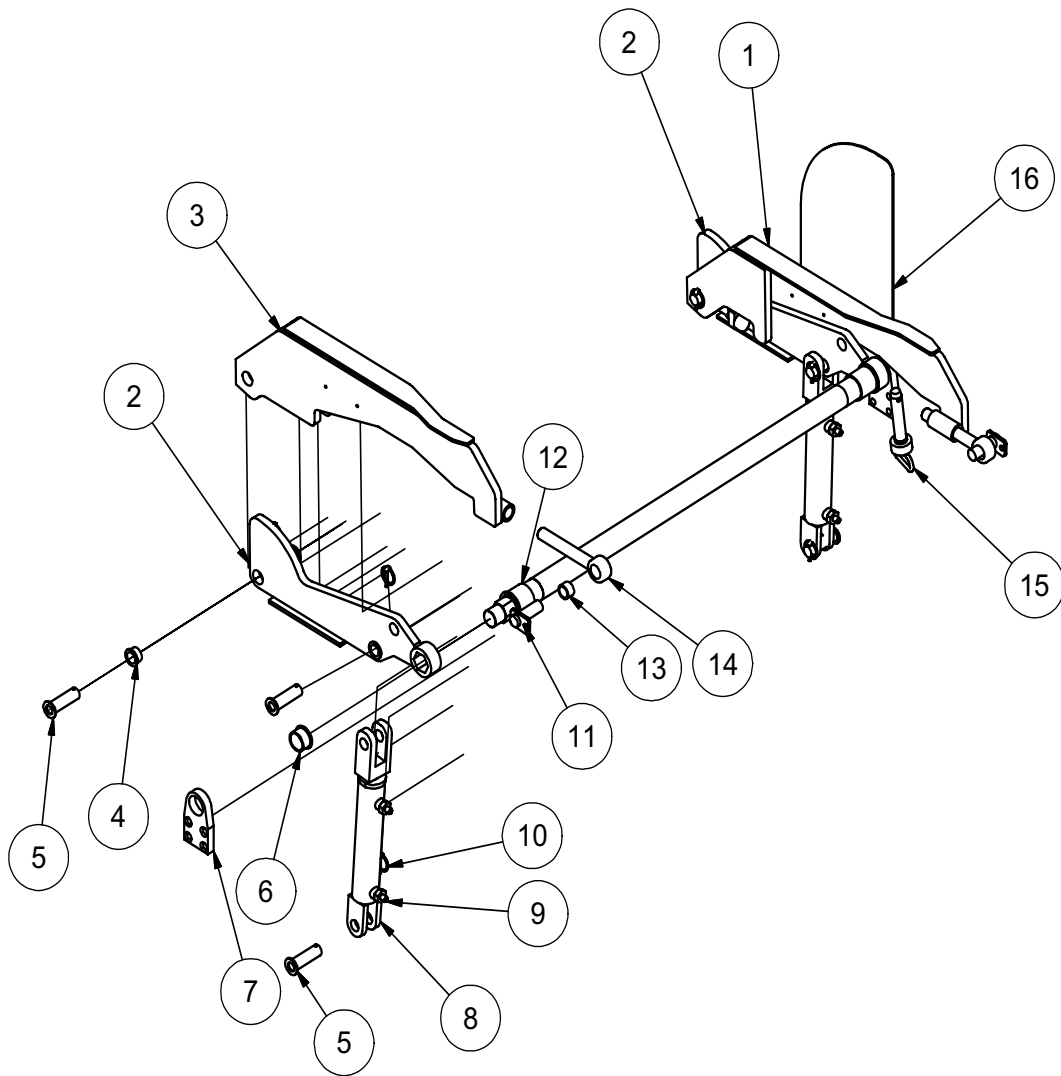

Hyd. Door Cylinder Assembly

ITEM	QTY	PART NO.	DESCRIPTION
1	1	8041369	DOOR HYD LONG LINKAGE WELDMENT
2	2	8041604	SHORT LINKAGE WELDMENT
3	1	8041375	DOOR HYD LONG LINKAGE SS WELDMENT
4	6	8041883	BUSHING BRONZE FLANGED 1"
5	6	8042489	HYD DOOR - PIN WELDMENT 1"DIA X 3"
6	2	8041649	BUSHING 1 1/4" MODIFIED
7	1	8041783	OUTER BEARING PLATE
8	2	8041327	HYD CYLINDER - 8" STROKE
9	4	T400611	UNION 8MB - 4MJ
10	6	U340050	PIN LINCH 3/16 X 1 9/16
11	2	8042171	DOOR CAPTURE PIN
12	2	8041602	BUSHING BRONZE FLANGED 2"
13	2	8041524	BUSHING BRONZE 1 1/4" X 1.00 X 3/4"LG
14	2	8043131	ROD END 1" X 7 1/2"
	2	U160025	NUT, JAM 1.00"
	2	U120060	NUT, NY LOCK 1"
	4	U200170	WASHER, FLAT 1.00"
15	1	8041626	1" X 4 1/2" HITCH PIN
16	1	8041635	HYDARM GUARD

Filtration

31LE

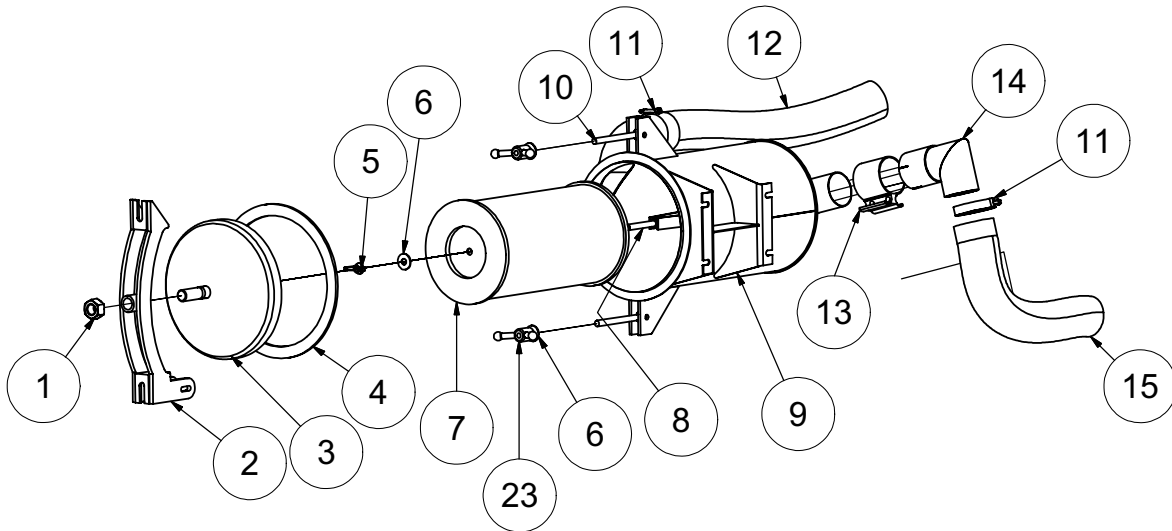
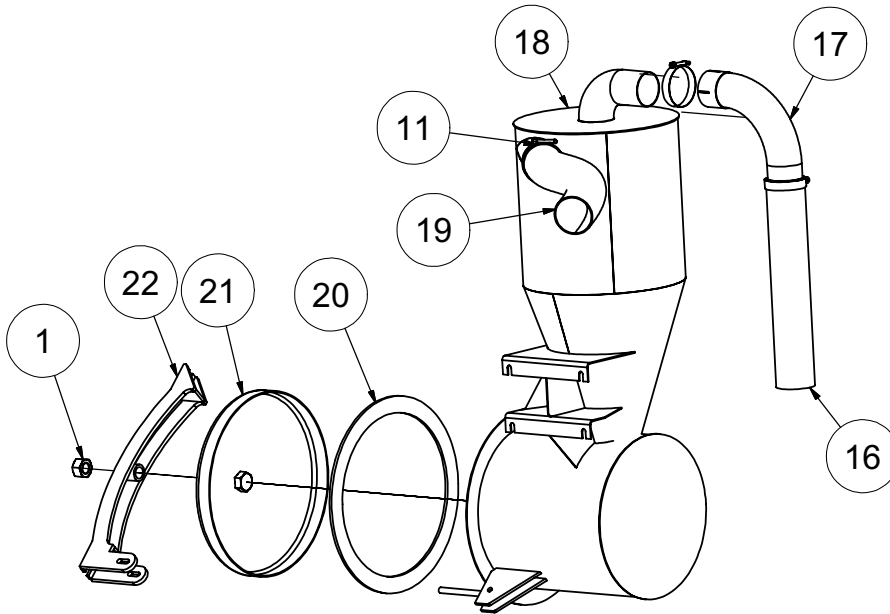

Filtration

31LE

ITEM	QTY	PART #	DESCRIPTION
1	2	U120060	NUT, LOCK NY 1" - 8
2	1	8044622	DOOR LATCH (AIR FILTER) - WELDMENT
3	1	8044620	575 RF AIR FILTER DOME
4	1	8044819	GASKET, REV FLOW AIR FILTER 575
5	1	U130080	NUT, WING 1/2-13
6	5	U200100	WASHER, FLAT 1/2
7	1	8031178	FILTER, ELEMENT 575 CFM
8	1	8040302	THREADED ROD - 4" LG
9	1	8044596	AIR FILTER 575RF
	4	U000420	SCREW, HC 3/8" - 16 X 1.00
	8	U200600	WASHER, FLAT 3/8"
	4	U210061	NUT, HEX NY 3/8 - 16
10	4	8041593	EYE BOLT
11	5	8042605	CLAMP T-BOLT 3" (350)
12	1	8046361	HOSE VAC AG SUCTION 3-53
13	2	8044914	3" BAND CLAMP
14	1	8044907	3" ELBOW MFG SHARP OD-ID W/SLEEVE
15	1	8046120	HOSE VAC AG SUCTION 3-15
16	1	8046363	HOSE VAC AG SUCTION 3-77
17	1	8040682	3" ELBOW 90 8" LEG
18	1	8044589	CYCLONE 575 REV FLOW
	4	U000420	SCREW, HC 3/8" - 16 X 1.00
	4	U200600	WASHER, FLAT 3/8"
	4	U210060	WASHER, LOCK 3/8"
19	1	8046362	HOSE VAC AG SUCTION 3-50
20	1	8041612	GASKET, REV FLOW CYCLONE
21	1	8041402	HD CYCLONE DOME DOOR ASSY
22	1	8041552	DOOR LATCH (CYCLONE) - WELDMENT
23	4	8041594	HANDLE, WING REV FLOW CYC/FILTE

Enclosure Assembly

31HP LE

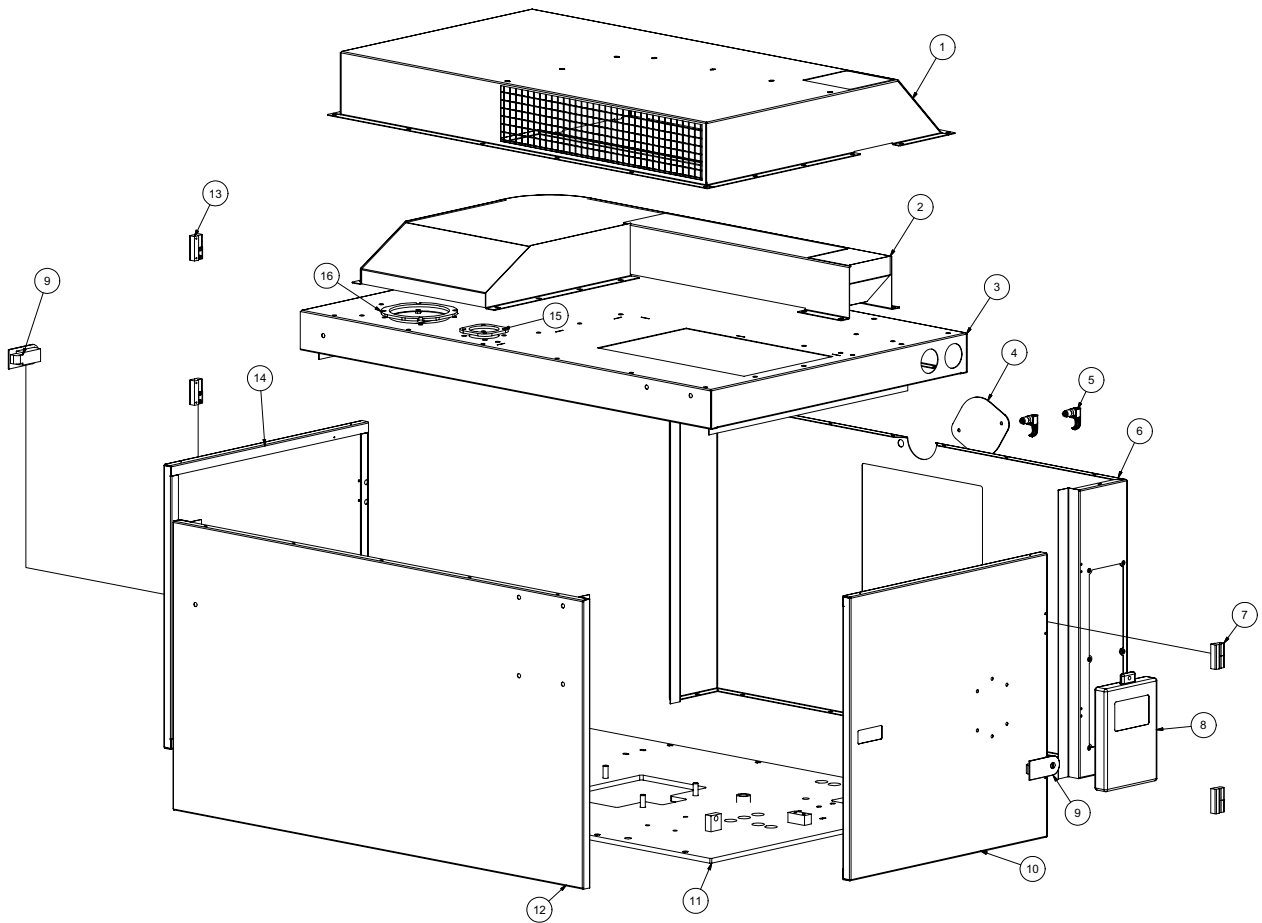

Enclosure Assembly

31HP LE

ITEM	QTY	PART NO.	DESCRIPTION
1	1	8045125	INTAKE BOX 31LE - WELDMENT
2	1	8045096	HEAT SHIELD 31LE - WELDMENT
3	1	8045090	31LE PANEL TOP WELDMENT
4	1	8040592	ENCLOSURE RADIATOR COVER
5	2	8040334	SWELL LATCH
6	1	8045086	31LE PANEL FRONT WELDMENT
*	1	8045110	SOUND INSULATION OPPOSITE CONTROL PANEL
*	2	8045117	SOUND INSULATION LEFT OR RIGHT SIDE RADIATOR
*	1	8045118	SOUND INSULATION BELOW RADIATOR
*	1	8045115	SOUND INSULATION ABOVE RADIATOR
*	1	8045108	SOUND INSULATION UPPER FRONT PANEL
*	1	8045114	SOUND INSULATION CONTROL PANEL TOP
*	1	8045119	SOUND INSULATION CONTROL PANEL BOTTOM
7	2	8040588	OFFSET HINGE TYPE "A"
8	1	8030689	BOX, PLASTIC FOR SAFETY MANUAL
9	2	8040586	SEALED LEVER LATCH
10	1	8045091	31LE PANEL DOOR FOR MANUAL
*	1	8045111	SOUND INSULATION DOOR
*	1	8045112	SOUND INSULATION UPPER CURB SIDE
11	1	8045050	MAIN PLATE 31LE - WELDMENT
12	1	8045088	31LE PANEL REAR WELDMENT
*	2	8045107	SOUND INSULATION BACK PANEL
*	1	8045134	SOUND INSULATION UPPER BACK PANEL
13	2	8040589	OFFSET HINGE TYPE "B"
14	1	8045092	31LE PANEL DOOR
*	1	8045111	SOUND INSULATION DOOR
*	1	8045109	SOUND INSULATION UPPER STREET SIDE
15	1	8045143	FLANGE EXHAUST TOP PANEL WELDMENT
16	1	8044223	ENCLOSURE EXHAUST CLAMP PLATE

* NOT SHOWN

Enclosure Assembly

31HP RC

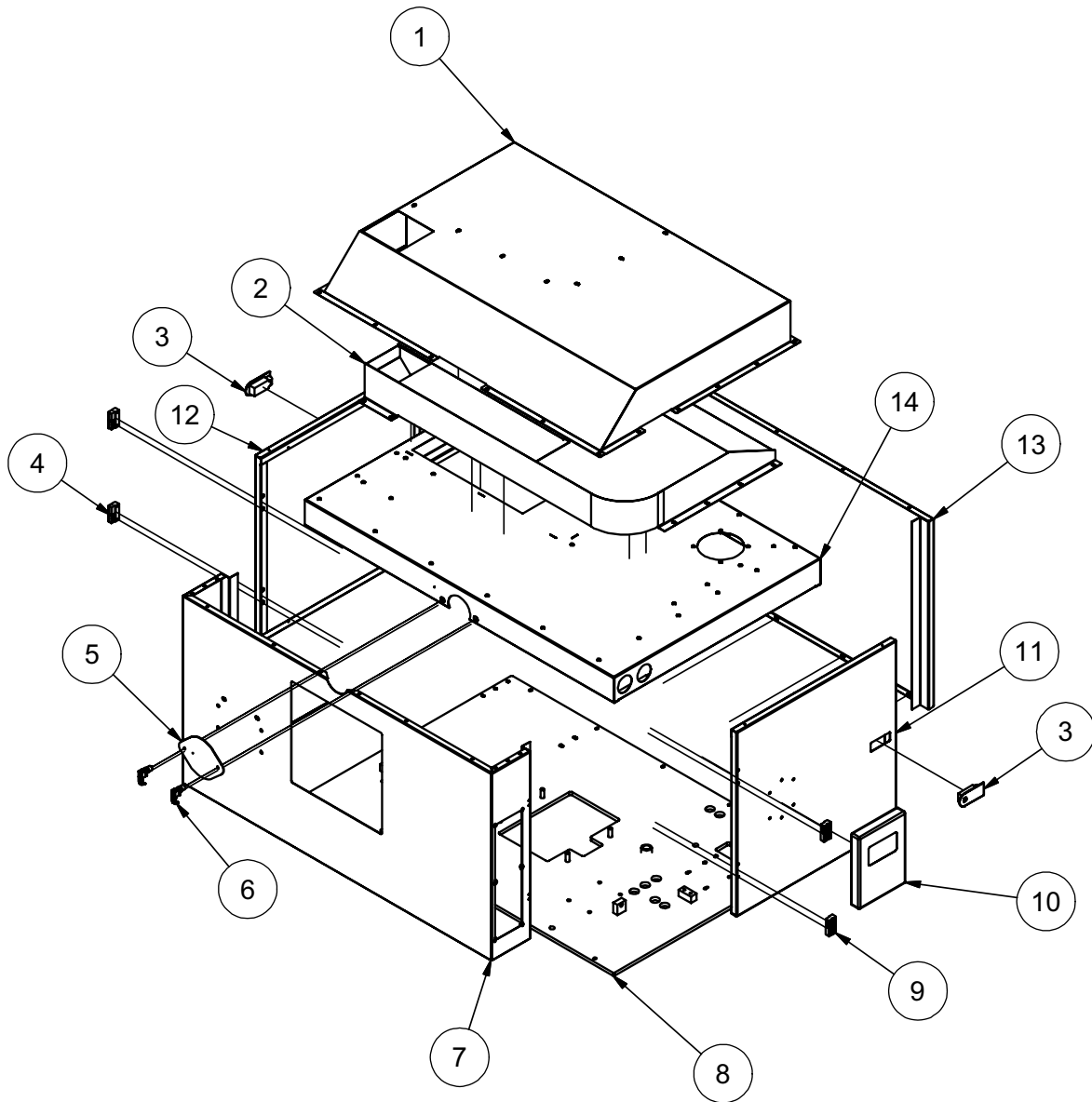

Enclosure Assembly

31HP RC

ITEM	QTY	PART NO.	DESCRIPTION
1	1	8045125	INTAKE BOX 31LE - WELDMENT
2	1	8045096	HEAT SHIELD 31LE - WELDMENT
3	2	8040586	SEALED LEVER LATCH
4	2	8040588	OFFSET HINGE TYPE "A"
5	1	8040592	ENCLOSURE RADIATOR COVER
6	2	8040334	SWELL LATCH
7	1	8045455	31LE PANEL FRONT WELDMENT
*	1	8045110	SOUND INSULATION OPPOSITE CONTROL PANEL
*	2	8045117	SOUND INSULATION LEFT OR RIGHT SIDE RADIATOR
*	1	8045118	SOUND INSULATION BELOW RADIATOR
*	1	8045115	SOUND INSULATION ABOVE RADIATOR
*	1	8045108	SOUND INSULATION UPPER FRONT PANEL
*	1	8045114	SOUND INSULATION CONTROL PANEL TOP
*	1	8045119	SOUND INSULATION CONTROL PANEL BOTTOM
8	1	8045050	MAIN PLATE 31LE-WELDMENT
9	2	8040589	OFFSET HINGE TYPE "B"
10	1	8030689	BOX, PLASTIC FOR SAFETY MAIN
11	1	8045091	31LE PANEL DOOR WELDMENT
*	1	8045111	SOUND INSULATION DOOR
*	1	8045112	SOUND INSULATION UPPER CURB SIDE
12	1	8045092	31LE PANEL DOOR
*	1	8045111	SOUND INSULATION DOOR
*	1	8045109	SOUND INSULATION UPPER STREET SIDE
13	1	8045088	31LE REAR WELDMENT
	2	8045107	SOUND INSULATION BACK PANEL
	1	8045134	SOUND INSULATION UPPER BACK PANEL
14	1	8045524	31LE TOP WELDMENT(OPP)

Engine Yanmar 3TNV82A

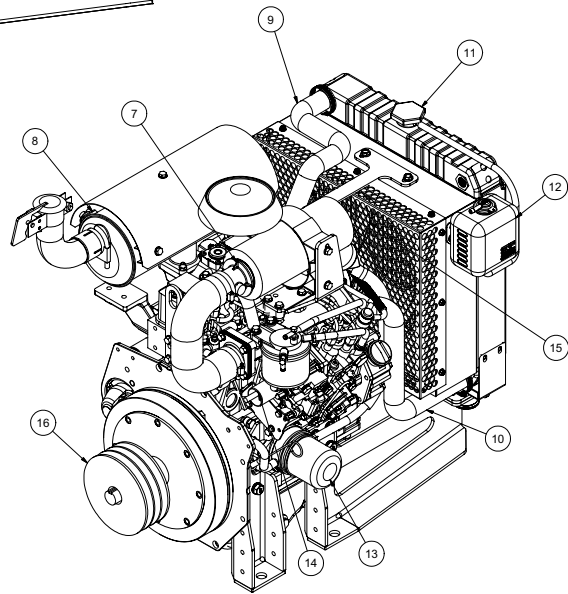
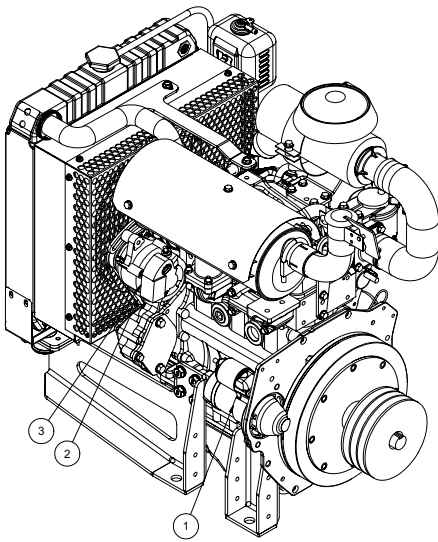
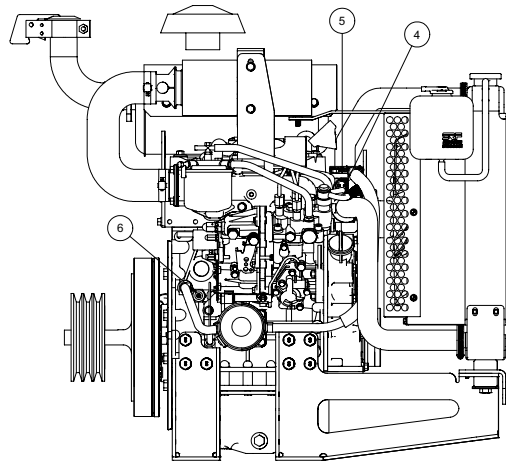

Engine Yanmar 3TNV82A

ITEM	QTY	NUMBER	DESCRIPTION
1	1	8045083-1	STARTER
2	1	8045083-2	FAN BELT
3	1	8045083-3	ALTERNATOR
4	1	8045083-4	WATER TEMPURTURE SWITCH
5	1	8045083-5	THERMOSTAT
6	1	8045083-6	OIL PRESSURE SWITCH
7	1	8045083-7	AIR FILTER HOUSING
*	1	8045277	AIR FILTER ELEMENT
8	1	8045083-8	MUFFLER
*	1	8045278	MUFFLER GASKET
9	1	8045083-9	UPPPER RADIATOR HOSE
10	1	8045083-10	LOWER RADIATOR HOSE
11	1	8045083-11	RADIATOR CAP
12	1	8045083-12	OVERFLOW TANK (SOLD WITH CAP)
13	1	8045083-13	OIL FILTER
14	1	8045083-14	FUEL SHUTOFF SOLENOID
15	1	8045083-15	FAN
16	1	8044548	SHEAVE, 7.75" OD SK 3-GROOVE
	1	8044516	BUSHING, 1 1/8" SK
*	1	8045279	THROTTLE SOLENOID
*	1	8045280	FUEL FILTER
*	1	8045281	FUEL PUMP
*	1	8045282	MURPHY SWITCH
*	1	8045283	KEY SWITCH
*	1	8045617	KEY
*	1	8045287	SOLENOID SPRING

* NOT SHOWN

Blower Assembly

31LE

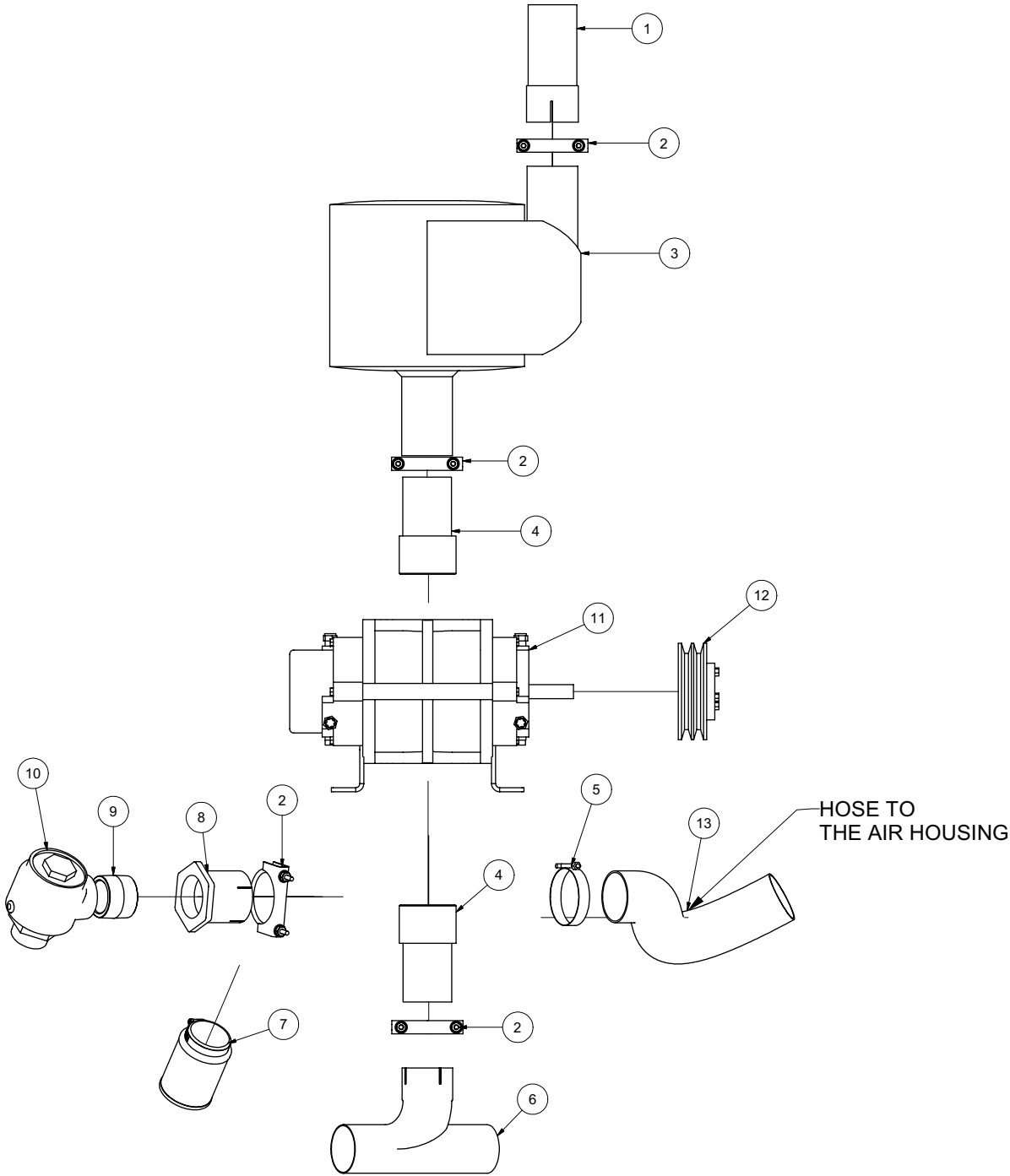

Blower Assembly

31LE

ITEM	QTY	PART NO.	DESCRIPTION
1	1	8045205	BLOWER EXHAUST EXTENSION
2	4	8030395	3" U-BOLT CLAMP
3	1	8030332	SILENCER, 500CFM, COWL
4	2	8030287	3" HOSE X 3"MNPT ADAPTER
5	1	8042605	CLAMP T-BOLT 3" (350)
6	1	8041033	WYE 3"OD STRAIGHT 3"ID BRANCH
7	1	8040340	FILTER, AIR FOR 2" KUNKLE VALVE
8	1	8045020	VADPT 3"-2" REDUCER X 3"ID
9	1	8030409	2" CLOSE NIPPLE
10	1	8030337	KUNKLE VALVE, 575CFM
11	1	8041250	BLOWER (MODEL 47)
	4	U000817	SCREW, HC 1/2"-13 X1"
	4	U210100	WASHER, LOCK 1/2"
	4	U200100	WASHER, FLAT 1/2"
12	1	8040945	5.95"OD SDS 2-GROOVE
	1	8040642	BUSHING 7/8" SDS
	1	U410042	KEY 3/16" X 3/16" X 2"
	1	8041797	RETAINER
	2	8030379	BX 51 BELT
13	1	8040336	HOSE VAC KANAFLEX 3-36

Blower Assembly

31LE RF

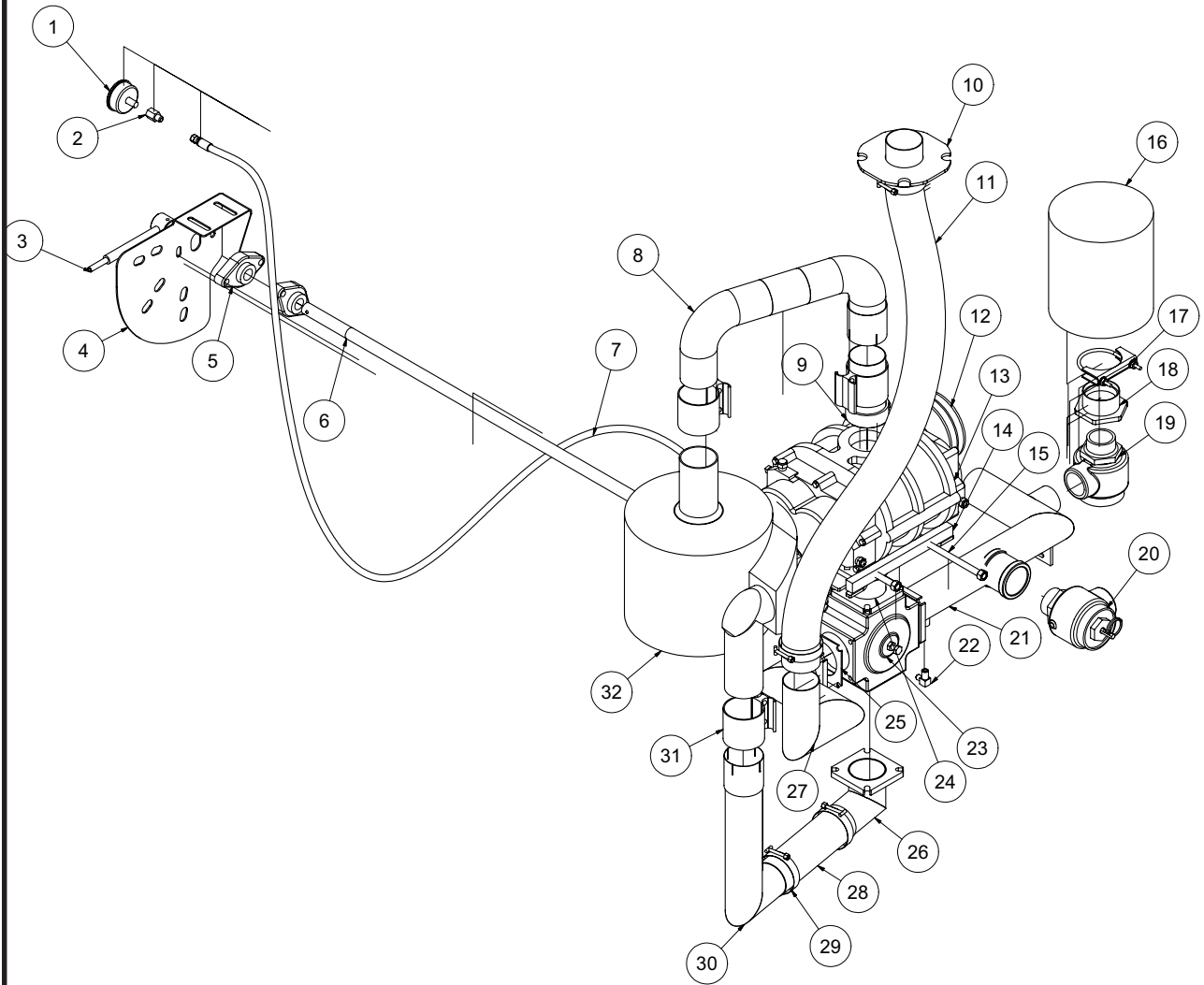

Blower Assembly

31LE RF

ITEM	QTY	NUMBER	DESCRIPTION
1	1	8030372	WATER PRESSURE GAUGE 1/4NPT
2	1	8030483	UNION 4FP - 4MJ
3	1	8041617	REVERSE FLOW HANDLE, TRAILER UNIT
4	1	8046202	BRACKET REV FLOW CONTROL LE
5	2	W030080	FLANGE BEARING - 2BOLT (1" BORE)
6	1	8046358	REV FLOW SHAFT 31LE
7	1	8044744	HOSE ASSY VAC 4-76 ST-ST
	2	T320030	FITTING, HOSE 4HO - 4FJ
8	1	8046356	EXHAUST U-PIPE WELDMENT 31LE RF
9	1	8045238	UNION EXHAUST 3" OD -MNPT
10	1	8046321	BRACKET EXHAUST BLOWER 575 31LE
11	1	8046360	HOSE VAC AG SUCTION 3-46"
12	1	8040945	SHEAVE 5.95DIA 2-GROOVE
	1	8040642	BUSHING, 7/8"SDS
	2	8030379	BELTS, BX 51
	1	8044986	RETAINER
13	1	8041250	BLOWER (MODEL 47)
	4	U000817	SCREW, HC 1/2" - 13 X 1"
	4	U210100	WASHER, LOCK 1/2"
	4	U200100	WASHER, FLAT 1/2"
14	1	8040702	TENSION BLOCK 575CFM
15	2	8040751	ROD TIGHTENER WELD'T
16	1	8043553	FILTER AIR 3" 245CFM
17	1	8030395	3" U-BOLT CLAMP
18	1	8044951	VACUUM RELIEF FILTER BUSHING
19	1	8030337	KUNKLE VALVE, 575CFM
20	1	8041034	PRESSURE RELIEF 575
21	1	8046352	3" HEADER W/FLANGE 36HP RF LE
22	1	T401100	ELBOW, 4MP-4MJ 90
23	1	8041030	VALVE, 4-WAY 3"NPT THREADS
24	1	8044905	ADAPTOR 4-WAY 3" VALVE (3") TO BLOWER
25	4	8044792	GASKET, 4-WAY VALVE 3"
26	1	8046345	ELBOW, 3" 90 4.5"LG X 5.5"LG W/FLANGE
27	1	8046341	OUTLET HEADER 3" 31HD RF
28	1	8046120	HOSE VAC AG SUCTION 3-15"
29	4	8042605	CLAMP T-BOLT 3" (350)
30	1	8046348	EXHAUST ELBOW 90, 13" X 7"LEG ID-OD
31	3	8044914	3" BAND CLAMP
32	1	8030332	SILENCER, 500CFM, COWL

Water Pump Assembly

31LE

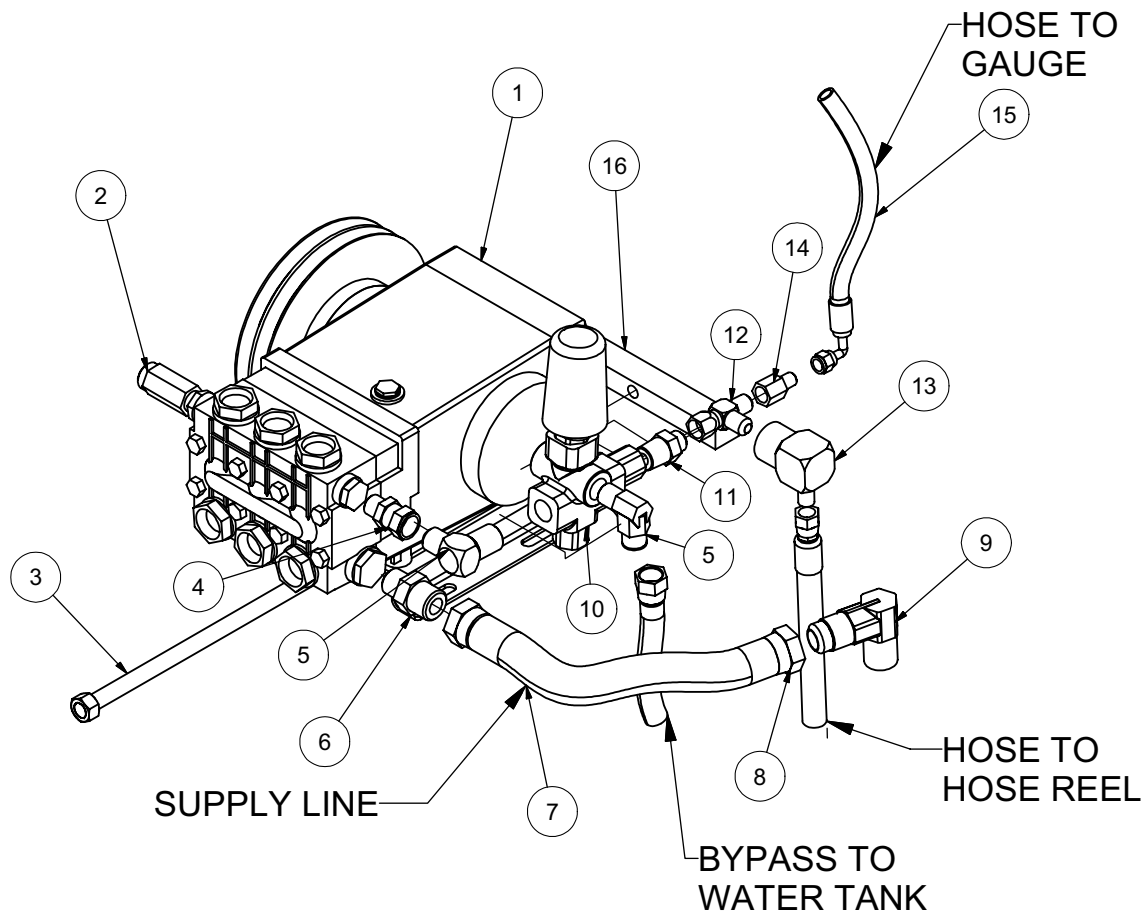

Water Pump Assembly

31LE

ITEM	QTY	PART NO.	DESCRIPTION
1	1	8031388	PUMP, WATER T2021L & CLUTCH 5.6
	2	8045875	BELT, AX41
2	1	8030340	VALVE, RELIEF
3	1	8040751	ROD TIGHTENER WELDT
4	1	T401125	REDUCER, 1/2"FJ - 3/8"MP
5	2	T401120	ELBOW, 3/8"MP-1/2"MJ
6	1	T400070	REDUCER, 1/2"MP - 3/4"MJ
7	1	8040972	HOSE VAC PUSH 12 - 8 1/2"
8	2	8030525	FITTING, PUSHLOCK #12
9	1	T401180	ELBOW, 90 3/4"MP - 3/4"MJ
10	1	8040177	VALVE, UNLOADER, PULSAR3
11	1	T400028	UNION, 3/8"MP - 3/8"MJ
12	1	T402153	TEE, 3/8"FJ - 3/8"MJ - 3/8"MJ
13	1	T401228	ELBOW, 3/8"MJ - 3/8"FJ
14	1	T400022	REDUCER, 3/8"FJ - 1/4"MJ
15	1	8044987	HOSE ASSY VAC 4-40 ST-90
	1	T320150	FITTING HOSE 4HO - 4FJ 90
	1	T320030	FITTING HOSE 4HO - 4FJ
16	1	8040893	TENSIONER BLOCK, ADJUSTING
*	1	8030372	WATER PRESSURE GAUGE 1/4NPT
*	1	T400110	UNION, 1/4FP - 1/4MJ

Water Pump TS2021

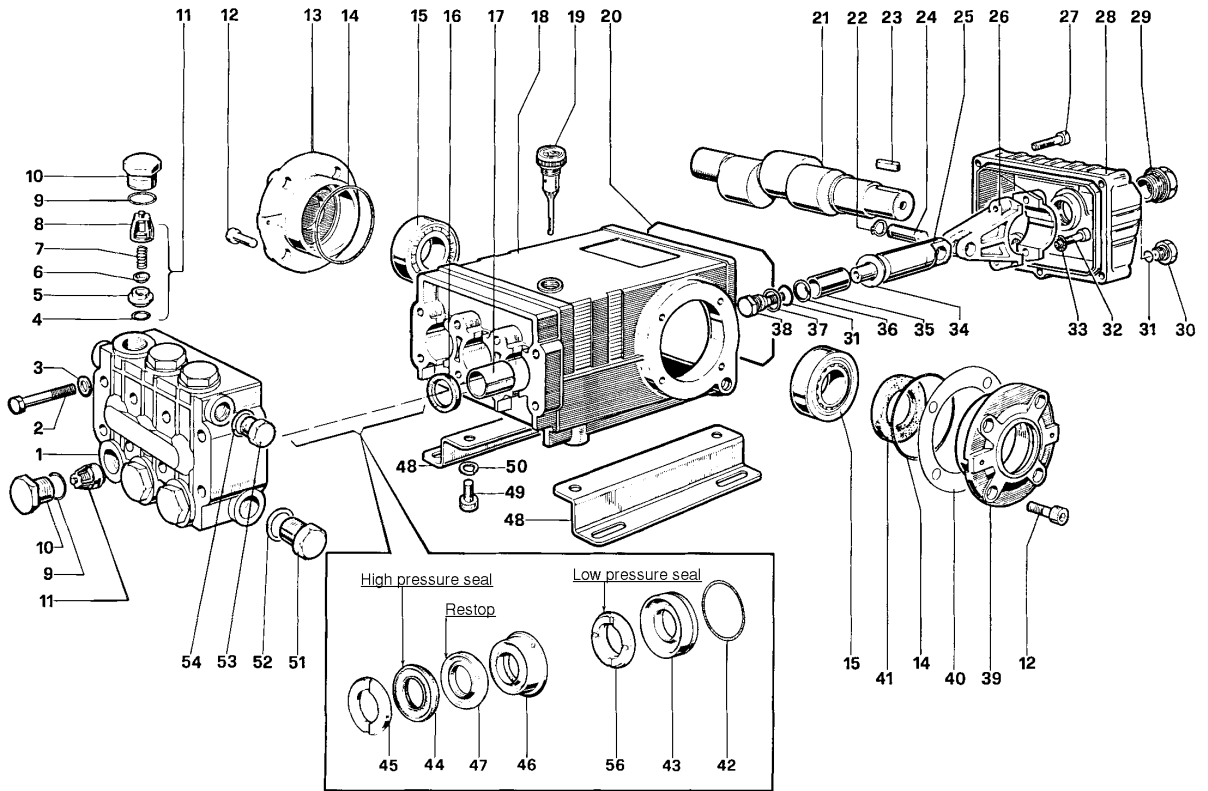

TORQUE SPECS*

*Decrease torque by 20%
if threads are lubricated

Position	Ft. Lbs.	N-M
2	22.1	29.9
10	73.7	99.9
12	14.7	19.2
27	7.3	9.9
29	13.2	17.9
30	14.7	19.2
32	14.7	19.2
38	14.7	19.2
49	29.4	39.8
51	29.4	39.8
53	29.4	39.8

Water Pump TS2021

ITEM	QTY.	PART #	DESCRIPTION	KIT #	ITEM #'S INCL'D IN KIT	NO. OF ASSY IN KIT	NO. OF CYL KIT WILL SERVICE
1	1	8031280-1	Manifold	8031280-KIT1	4, 5, 6, 7, 8 (11)	6	3
2	8	8031280-2	Screw, M8 x 70	8031280-KIT2	16	3	3
3	8	8031280-3	Washer, M8 x 4	8031280-KIT3	41	2	0
4	8	8031280-4	O-ring, .674 x .103	8031280-KIT4	9, 10	6	3
5	6	8031280-5	Seat, Valve	8031280-KIT5	9, 10	6	3
6	6	8031280-6	Plate, Valve	8031280-KIT6	31, 34	3	3
7	6	8031280-7	Spring		36, 37, 38		
8	6	8031280-8	Guide, Valve	8031280-KIT7	45	6	3
9	6	8031280-9	O-ring,.797x.103	8031280-KIT10	42, 43	3	3
10	6	8031280-10	Cap	8031280-KIT28	42, 43, 44,	1	1
11	6	8031280-11	Valve Assembly		45, 45, 47, 56		
12	8	8031280-12	Screw, M8 x 16	8031280-KIT69	44, 47, 56	3	3
13	1	8031280-13	Cover, Crankcase	8031280-KIT71	46, 47	3	3
14	2	8031280-14	O-ring, 2.675 x .103				
15	2	8031280-15	Bearing, Roller				
16	3	8031280-16	Seal, Oil				
17	3	8031280-17	Bushing				
18	1	8031280-18	Crankcase				
19	1	8031280-19	Oil Dip Stick				
20	1	8031280-20	O-ring, Cover				
21	1	8031280-21	Crankshaft				
22	6	8031280-22	Ring, Snap				
23	1	8031280-23	Key				
24	3	8031280-24	Pin, Wrist				
25	3	8031280-25	Guide, Plunger				
26	3	8031280-26	Rod, Connecting				
27	5	8031280-27	Screw, M6 x 30				
28	1	8031280-28	Cover, Crankcase				
29	6	8031280-29	Oil Indicator				
30	1	8031280-30	Cap				
31	4	8031280-31	O-ring,.426x.070				
32	6	8031280-32	Screw, M8 x 35				
33	6	8031280-33	Washer, M8.4				
34	3	8031280-34	Washer, M14				
35	3	8031280-35	Plunger (20 mm)				
37	3	8031280-37	Washer				
38	3	8031280-38	Screw, Plunger				
39	1	8031280-39	Cover, Crankcase				
40	2	8031280-40	Shim				
41	1	8031280-41	Seal, Oil				
42	3	8031280-42	O-ring, 1.364x.070				
43	3	8031280-43	Retainer, Packing				
44	3	8031280-44	Packing				
45	3	8031280-45	Ring, Head, M20				
46	3	8031280-46	Intermed. Ring				
47	3	8031280-47	Testop Ring				
48	2	8031280-48	Pump Feet				
49	4	8031280-49	Screw, M10 x 18				
50	4	8031280-50	Washer, M10.2				
51	1	8031280-51	Cap				
52	1	8031280-52	Washer, M21.5				
53	1	8031280-53	Cap				
54	1	8031280-54	Washer, M17.5				
56	3	8031280-56	Seal,Low Press,20mm				

Unloader Valve PULSAR3KHP

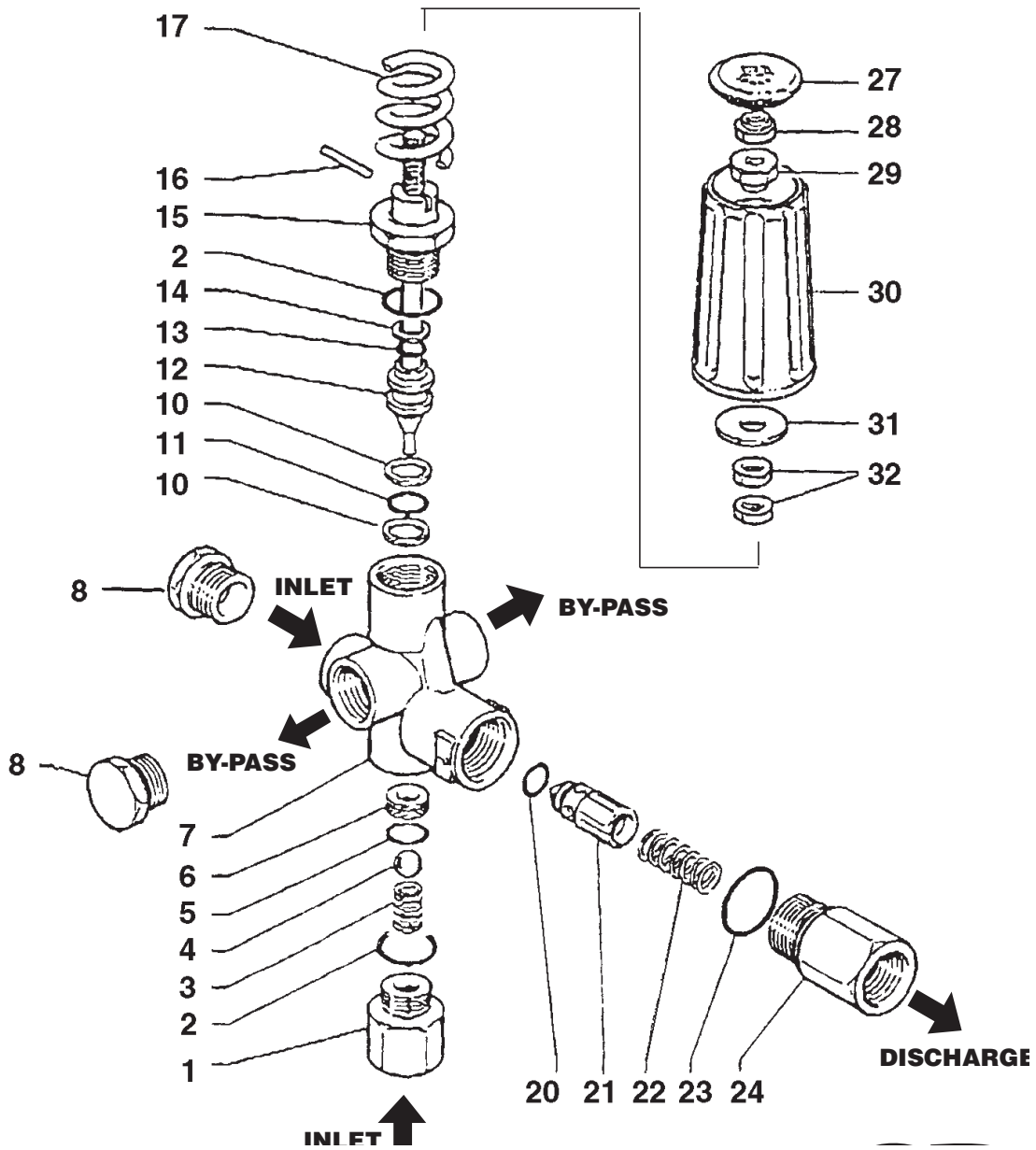

Unloader Valve PULSAR3KHP

ITEM	QTY	PART #	DESCRIPTION
1	1	8040177-1	INLET FITTING, 3/8 NPT-F
2	2	8040177-2	O-RING, .676ID X .070CS
3	1	8040177-3	BALL SPRING
4	1	8040177-4	SS BALL, 13/32
5	1	8040177-5	O-RING, .437ID X .070CS
6	1	8040177-6	SS SEAT, .551OD X .335ID
7	1	8040177-7	BRASS BODY, 3/8 NPT
8	2	8040177-8	PLUG, 3/8"NPT
10	2	8040177-10	BACKUP RING
11	1	8040177-11	O-RING, .424ID X .103CS
12	1	8040177-12	SS PISTON
13	1	8040177-13	OORING, .299ID X .103CS
14	1	8040177-14	BACKUP RING
15	1	8040177-15	PISTON HOUSING
16	1	8040177-16	LOCKING PIN
17	1	8040177-17	BLUE SPRING
20	1	8040177-20	O-RING, .236ID X .118CS
21	1	8040177-21	CHECK VALVE
22	1	8040177-22	SS SPRING
23	1	8040177-23	O-RING, .739ID X .070CS
24	1	8040177-24	OUTLET FITTING, 3/8NPT-F
27	1	8040177-27	PLASTIC PLUG for KNOB
28	1	8040177-28	ZINC NUT, M8
29	1	8040177-29	INSERT M8
30	1	8040177-30	PLASTIC KNOB
31	1	8040177-31	WASHER, 9mm X 24mm
32	2	8040177-32	BRASS NUT, M8

Electrical Control Bracket

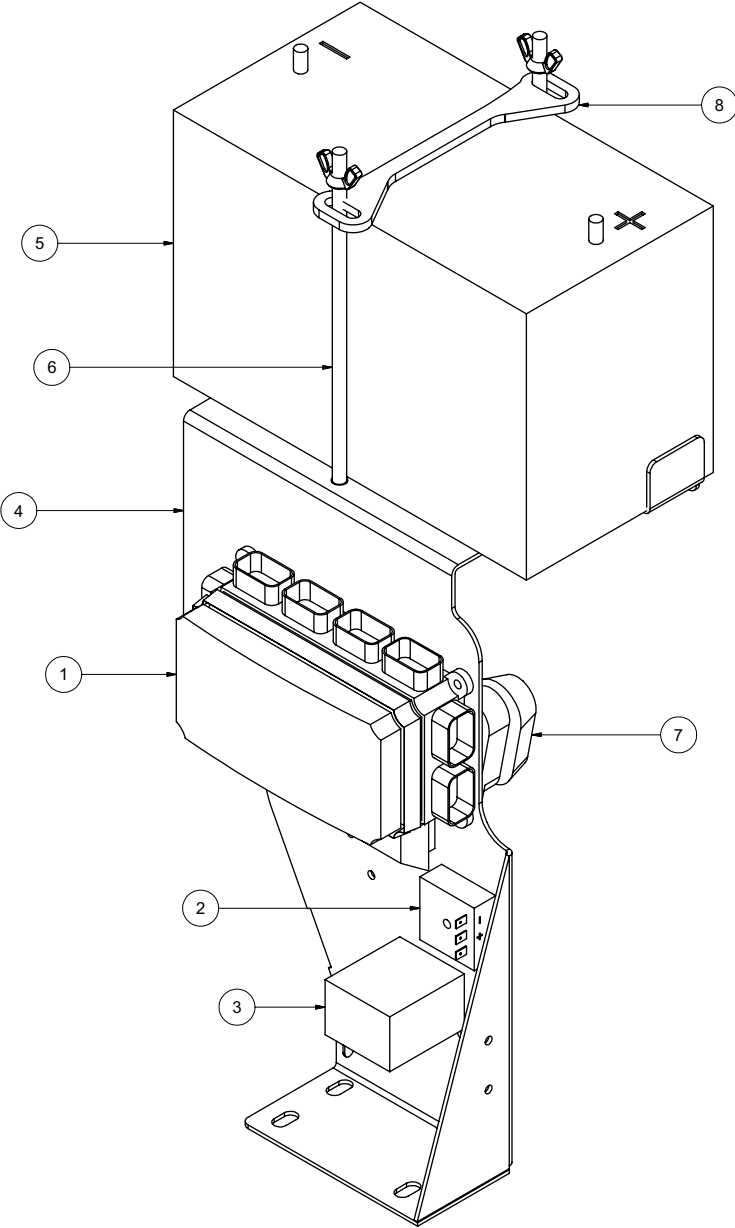

Electrical Control Bracket

ITEM	QTY	PART NO.	DESCRIPTION
1	1	X000213	BUSSMAN VEC
2	1	8031231	SWITCH, DELAY RELAY
3	1	X000240	RELAY TIME 15 SECOND
4	1	8043129	CONTROL PANEL - HARNESS MTG PLATE
5	1	X400050	BATTERY, 31-MHD WORKAHOLIC
6	2	8043742	BATTERY HOLD DOWN ROD ASSY
7	1	8043800	FUSE HOLDER AMG
8	1	8050016	BATTERY HOLD DOWN
*	1	X200005	HARNESS VAC CONTROL
*	1	X300218	BATTERY GROUND CABLE
*	4	X300181	BATTERY HOT CABLE

* NOT SHOWN

Control Panel

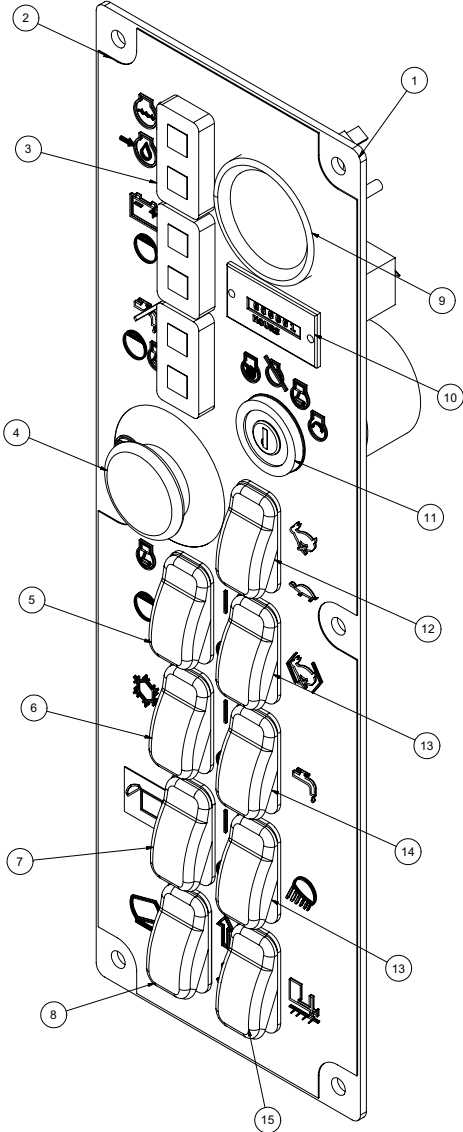
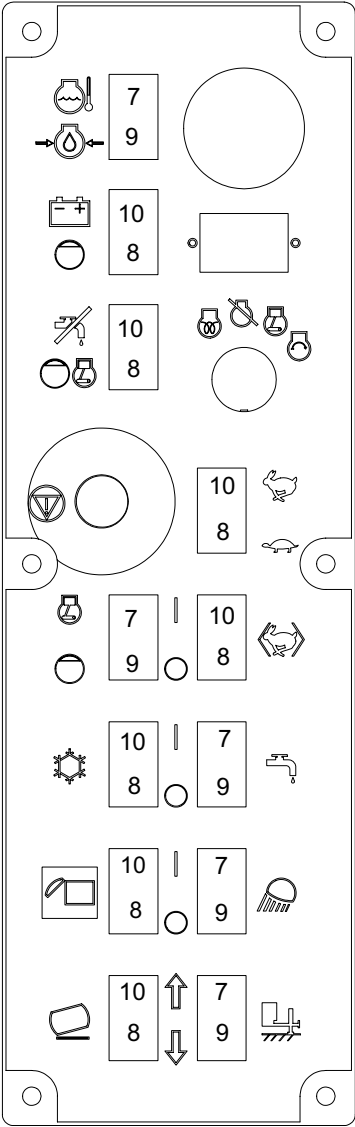

Control Panel

ITEM	QTY	PART NO.	DESCRIPTION
1	1	8043128	CONTROL PANEL - MAIN PLATE
2	1	J200031	DECAL - CONTROL PANEL
3	3	X000260	LIGHT LED DUAL PANEL
4	1	X000280	E-STOP
5	1	X000273	ROCKER SWITCH SPST (ON) NONE -OFF
6	1	X000272	ROCKER SWITCH DPST (ON) NONE -ON
7	1	X000272	ROCKER SWITCH DPST (ON) NONE - ON
8	1	X000274	ROCKER SWITCH DPDT (ON) OFF (ON)
9	1	X100001	FUEL GAUGE
10	1	X000300	HOUR METER
11	1	8030458	IGNITION SWITCH
12	1	X000271	ROCKER SWITCH DPST ON - ON
13	2	X000270	ROCKER SWITCH SPST ON -OFF
14	1	X000270	ROCKER SWITCH SPST ON -OFF
	1	X000271	ROCKER SWITCH DPST ON -ON
15	1	X000290	ROCKER SWITCH PLUG
	1	X000274	ROCKER SWITCH DPDT (HYD. JACK OPTION)
*	1	8030829	KEY, IGNITION - KUBOTA

* NOT SHOWN

Hydraulic Pump Assembly

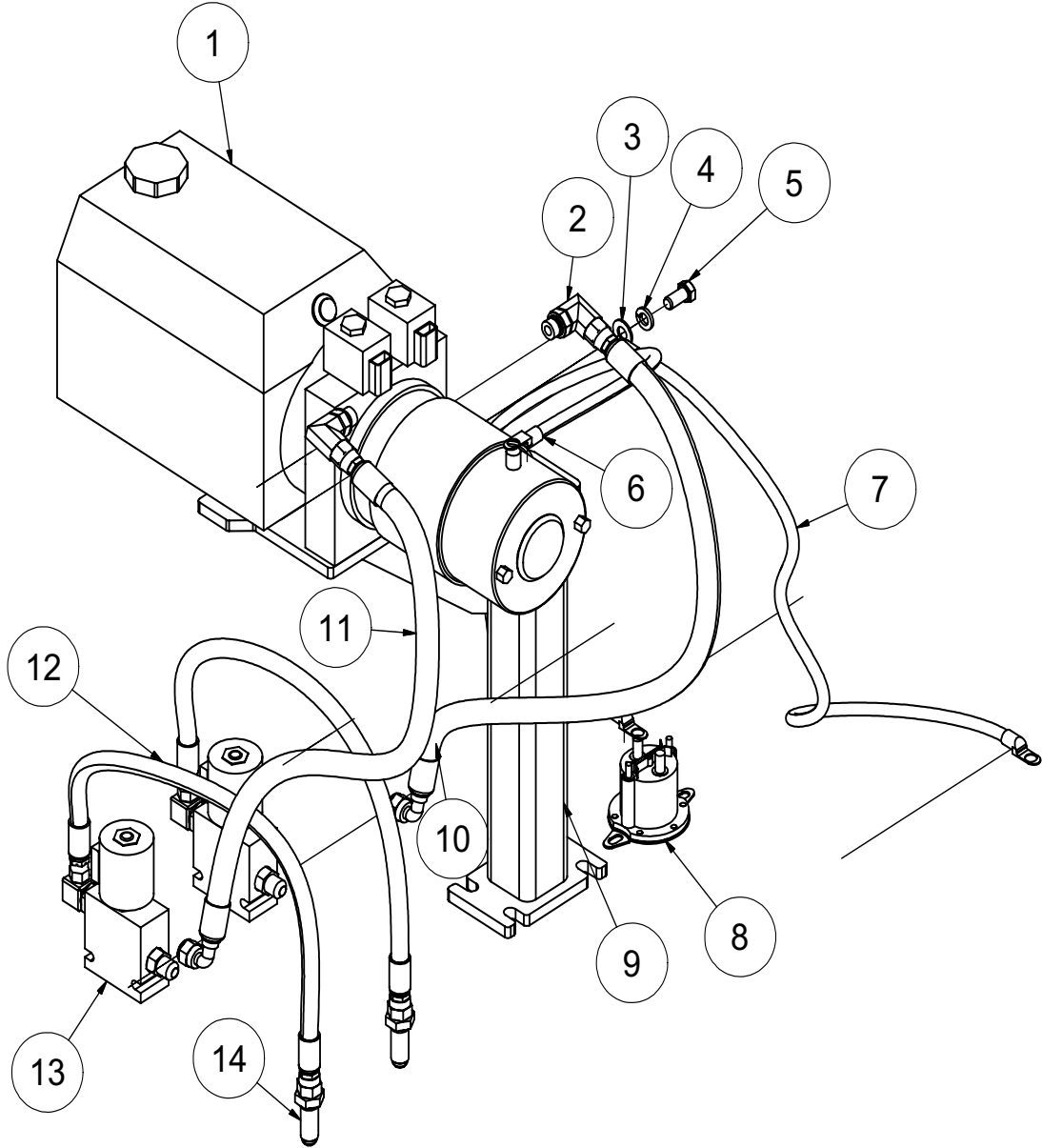

Hydraulic Pump Assembly

ITEM	QTY	PART	DESCRIPTION
1	1	8046300	PUMP, HYD 12V 6QT
2	2	T401250	ELBOW, 90 3/8" MB-MJ
3	1	U200600	WASHER, FLAT 3/8"
4	1	U210060	WASHER, LOCK 3/8"
5	1	U200400	SCREW, HC 3/8"-16 X .750
6	1	X300233	CABLE, BATTERY HOT 1GA 26"
	2	X300251	LUG, CABLE 1GA 3/8" HOLE
7	1	X300224	CABLE, BATTERY GROUND 1GA 21"
	2	X300251	LUG, CABLE 1GA 3/8" HOLE
8	1	8046258	SWITCH HYD PUMP 12V RELOCATE
9	1	8043499	BRACKET 36/49 12V HYD PUMP
10	1	8046685	HOSE ASSY VAC 6-25" ST-90 (500LE/LEHD)
	1	8046686	HOSE ASSY VAC 6-22" ST-90 (800LE/LEHD)
	1	8040973	HOSE ASSY VAC 6-20" ST-90 (73/99)
11	1	8046687	HOSE ASSY VAC 6-23" ST-90 (500LE/LEHD)
	1	8040973	HOSE ASSY VAC 6-20" ST-90 (800LE/LEHD)
	1	8040973	HOSE ASSY VAC 6-20" ST-90 (73/99)
12	2	8040971	HOSE ASSY VAC 4-19" ST-ST6FJ (LE/LEHD)
13	2	8041788	VALVE, SOLENOID 3-WAY W/ INT C4K
14	2	T400391	BULKHEAD 3/8" MJ - 3/8" MJ

* NOT SHOWN

Hydraulic Pump w/ Bracket

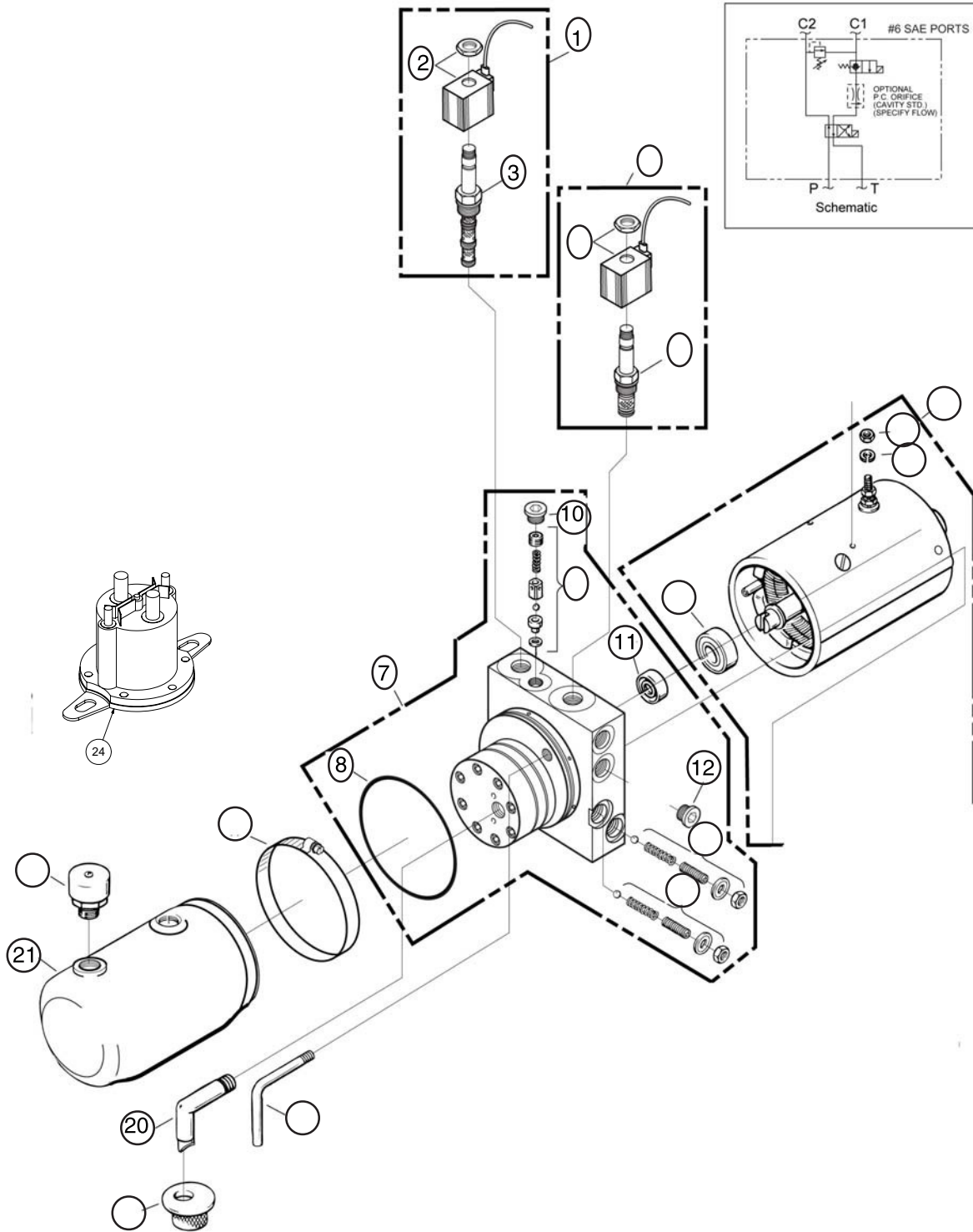

Hydraulic Pump w/ Bracket

ITEM	QTY	NUMBER	DESCRIPTION
	1	8046300	PUMP, HYD 12V VAC 4.5QT
	2	U000420	SCREW, HC 3/8"-16 X 1"
	2	U210060	WASHER, LOCK 3/8"
	2	U200600	WASHER, FLAT 3/8"
	2	T400037	UNION 6MB - 6MJR
	2	8040973	HOSE ASSY VAC 6-20 ST-90
	2	T400391	BULKHEAD 6MP - 6MP
1	1	8046300-14	VALVE, 4-WAY - 2 POSITION
2	1	8046300-15	COIL, 10VDC GROUNDED W/ DEUTSCH CONN
3	1	8046300-16	CARTRIDGE, 4-WAY 2 POSITION
4	1	8046300-17	VALVE, 2-WAY 2 POSITION (12V) GROUNDED
5	1	8046300-18	COIL, 10VDC 2-WAY 2 POS GRND W/ DEUTSCH CONN
6	1	8046300-19	VALVE, 12V HYD 2-WAY 2 POSITION
7	1	8046300-23	PUMP ASSEMBLY
8	1	8046300-24	O-RING INDUST 3 5/8" X 3 7/8" X 1/8"
9	1	8046300-25	PARTS KIT - VALVE ASSY, POPPET/BALL CHECK
10	1	8046300-26	PLUG
11	1	8046300-27	SEAL
12	1	8046300-28	PLUG, #8 SAE
13	2	8046300-30	PARTS KIT, RELIEF VALVE
14	1	8046300-31	MOTOR, ELECTRIC 12VDC
15	1	8046300-32	BEARING, BASE MOTOR
16	1	8046300-33	NUT, HEX 5/16 -24
17	1	8046300-34	WASHER, LOCK 5/16"
	2	8046300-38	SCREW, HEX HEAD 1/4"-20 X 1 3/8"
	1	8046300-41	PLUG, 3/8"NPTF
18	1	8046300-42	TUBE, RETURN (1/8")
19	1	8046300-43	SCREEN, FILTER (SUCTION)
20	1	8046300-44	TUBE, FILTER SUCTION 3/8"NPT 90 DEG
21	1	8046300-45	6QT RESEVOIR POLY
	*	8040486-45	3QT RESEVOIR POLY
	*	8046300-48	4.5QT RESEVOIR POLY
22	1	8046300-46	PLUG, VENT 3/8"NPT
23	1	8046300-47	CLAMP, HOSE WORM GEAR (IN SERIES)
24	1	8046258	SWITCH HYD PUMP 12V
	1	X200002	HYDRAULIC PUMP WIRE HARNESS
	1	8043499	HYDRAULIC PUMP MOUNT
		8044297	HYDRAULIC PUMP MOUNT (REVERSE FLOW)
		8045336	HYDRAULIC PUMP MOUNT (412 BLOWER)

* NOT SHOWN

Water Tank Assembly

125 Gallon Saddle Tanks 31LEG/LE

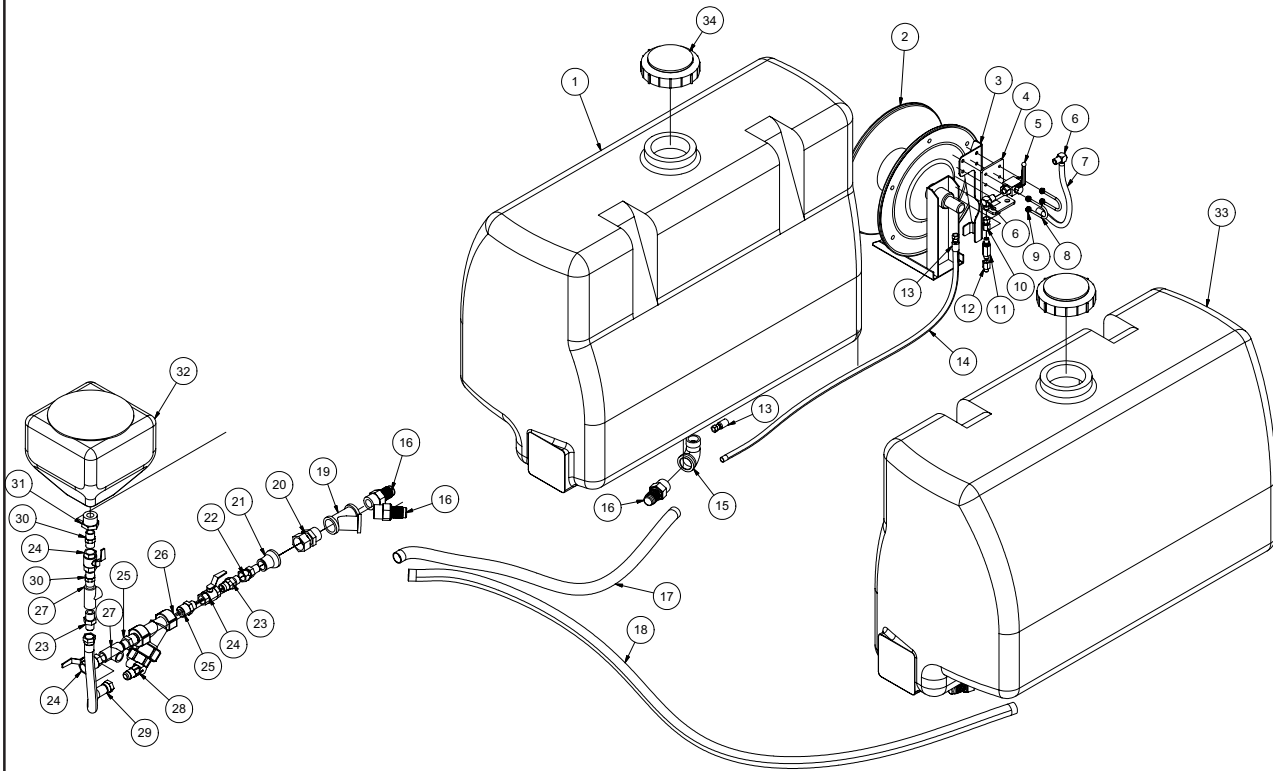

Water Tank Assembly

125 Gallon Saddle Tanks 31LEG/LE

ITEM	QTY	NUMBER	DESCRIPTION
1	1	8040782-1	TANK, WATER SADDLE (125 GAL) CURB SIDE
2	1	8043927	HOSE REEL SP 3/8"
	4	U000420	SCREW, HC 3/8"-16 X 1.0
	8	U200060	WASHER, FLAT 3/8"
	4	U210060	WASHER, LOCK 3/8"
	4	U100060	NUT, HEX 3/8"-16
	1	8041830	HOSE ASSY VAC 3/8" X 50' 4000PSI
3	1	8043094	WATER HOSE VALVE BRACKET
4	1	8040670	BALL VALVE BRACKET
5	1	8030351	STEEL BALL VALVE - 3/8"NPT
6	2	T401102	ELBOW, 6MJ-6MP
7	1	8044147	HOSE REEL SUPPLY HOSE 6-10 ST-ST
8	2	U010017	1 1/2" CLAMP HOOK 1/4-20 THD
9	4	U120100	NUT, LOCK 1/4-20
	4	U200020	WASHER, FLAT 1/4"
10	1	8031125	UNION, 4FP-6FJ
11	1	8030923	FILTER, WATER HIGH PRESSURE
12	1	8031126	UNION, 4FP-6MJ
13	2	T320040	FITTING, HOSE 6HO-6FJ
14	1	8045262	HOSE ASSY VAC 6-125 ST-ST
15	2	T420120	STREET ELBOW 90 - 1 1/4
16	4	8044266	FITTING, HOSE BARB 20HB-20MP
17	1	8044637	HOSE VAC VINLY 1 1/4-30
18	1	8045263	HOSE VAC VINLY 1 1/4-54
19	1	8045201	WYE, 1 1/4"FP 45DEG BLACK PIPE
20	1	8045203	UNION, 1 1/4"MP - 1 1/4"FP SWIVL
21	1	8045202	COUPLING, PIPE 1 1/4 X 3/4
22	1	T400101	UNION, 3/4"FJ - 3/4"MP
23	1	T400100	UNION, 12MP-12MJ
24	3	T000185	VALVE, BALL 3/4"FNPT BRASS
25	2	T404060	UNION, 16MP-12MP
26	1	8040186	STRAINER "Y" BANJO
27	2	T402160	TEE, 3/4"FP - 3/4"FP - 3/4"FP
28	1	T401180	ELBOW, 90 3/4"MP - 3/4"MP
29	1	8043688	HOSE VAC PUSH 12-20
	2	8030525	FITTING, PUSHLOCK #12
30	3	T400800	UNION, 12MP - 12MP
31	1	T403100	REDUCER, 20MP - 12FP
32	1	8030394	ANTI-FREEZE TANK 4GA.
33	1	8040782	TANK, WATER SADDLE (125 GAL) STREET SIDE
35	2	8041119	LID, 125 GAL TANK

Water Tank Assembly

50Gallon Saddle Tanks 31LE

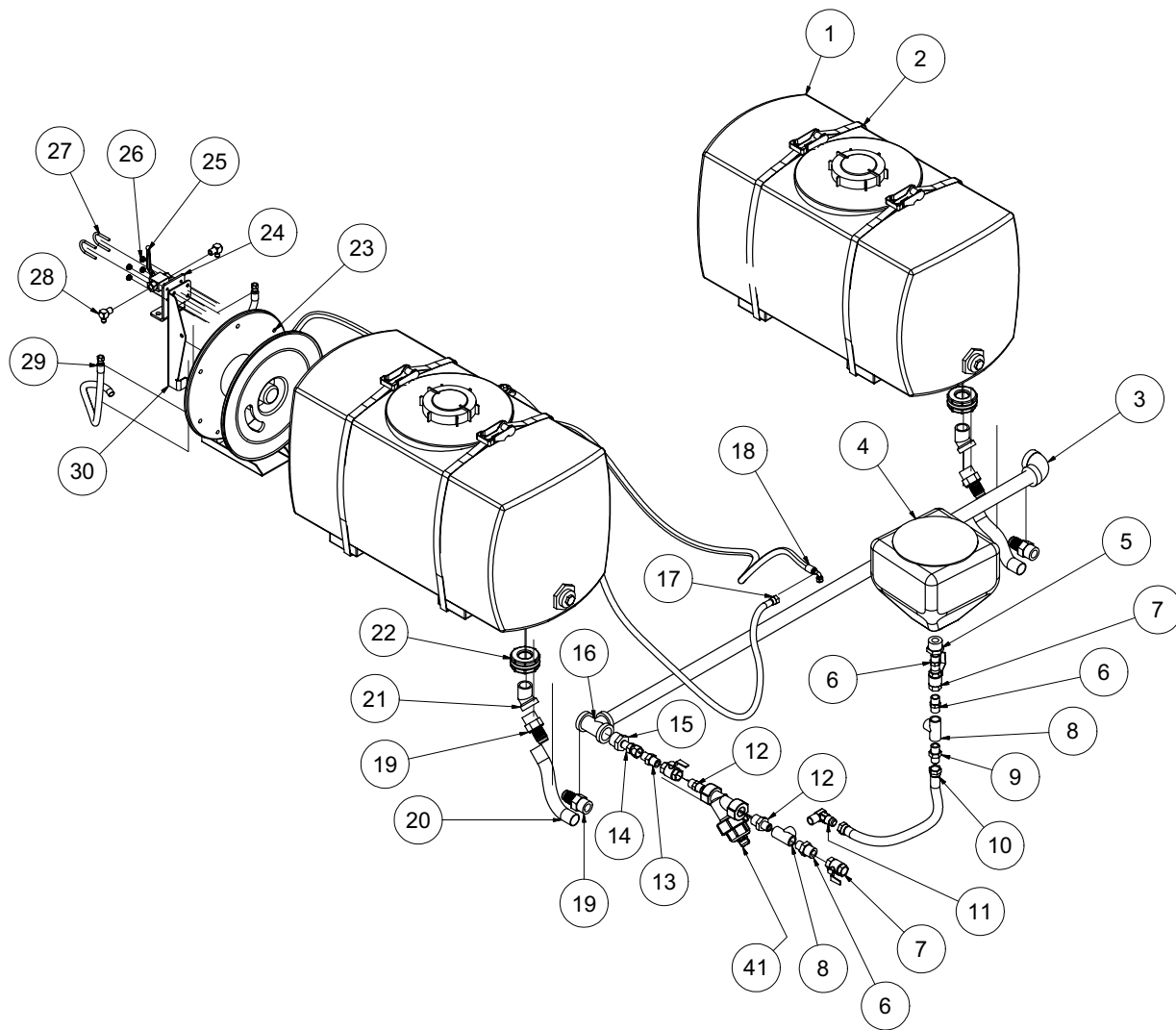

Water Tank Assembly

50Gallon Saddle Tanks 31LE

ITEM	QTY	PART NO.	DESCRIPTION
1	2	8034151	50 GALLON WATER TANK
2	4	8043758	STRAP, EYEBOLT 1" X 55" OAL
3	1	8041309	ELBOW, 1 1/4"FP - 1 1/4"FP
4	1	8030394	ANTI-FREEZE TANK 4GA.
5	1	T403100	REDUCER, 20MP - 12FP
6	4	T400800	UNION, 12MP - 12MP
7	3	T000185	VALVE, BALL 3/4"FNPT BRASS
8	2	T402160	TEE, 3/4"FP - 3/4"FP - 3/4"FP
9	1	T400100	UNION, 12MP -12MJ
10	1	8043688	HOSE VAC PUSH 12-20
	2	8030525	FITTING, PUSHLOCK #12
11	1	T401180	ELBOW, 90 3/4"MP - 3/4"MP
12	2	T404060	UNION, 16MP - 12MP
13	1	T400100	UNION, 12MP - 12MJ
14	1	T400101	UNION, 12FJ - 12MP
15	1	T403100	REDUCER, 20MP - 12FP
16	1	8041310	TEE, 1 1/4"FP - 1 1/4"FP - 1 1/4"FP
17	1	8043977	HOSE VAC PUSH 8-102
	2	8030524	FITTING, PUSHLOCK #12
18	1	8041476	HOSE ASSY VAC 6 - 150 ST-90
19	4	8041312	FITTING, HOSE BARB 1 1/4"
20	2	8044637	HOSE VAC VINYL 1 1/4" - 30
21	2	8041526	ELBOW, 45 STREET 1 1/4"
22	2	8041044	BULKHEAD, 1 1/4"FNPT - PLASTIC
23	1	8043927	HOSE REEL SP 3/8"
	4	U000420	SCREW, HC 3/8" - 16 X 1.00
	8	U200060	WASHER, FLAT 3/8"
	4	U210060	WASHER, LOCK 3/8"
	4	U100060	NUT, HEX 3/8" - 16
	1	8041830	HOSE ASSY VAC 3/8" X 50' 4000PSI
24	1	8040670	BALL VALVE BRACKET
25	1	8030351	STEEL BALL VALVE - 3/8"NPT
26	4	U120100	NUT, LOCK 1/4"-20
	4	U200020	WASHER, FLAT 1/4"
27	2	U010017	1 1/2" CLAMP HOOK 1/4"-20
28	2	T401102	ELBOW, 6MJ-6MP
29	1	8044147	HOSE REEL SUPPLY HOSE 6-10 ST-ST
30	1	8043094	WATER HOSE VALVE BRACKET

Hose Reel Assembly

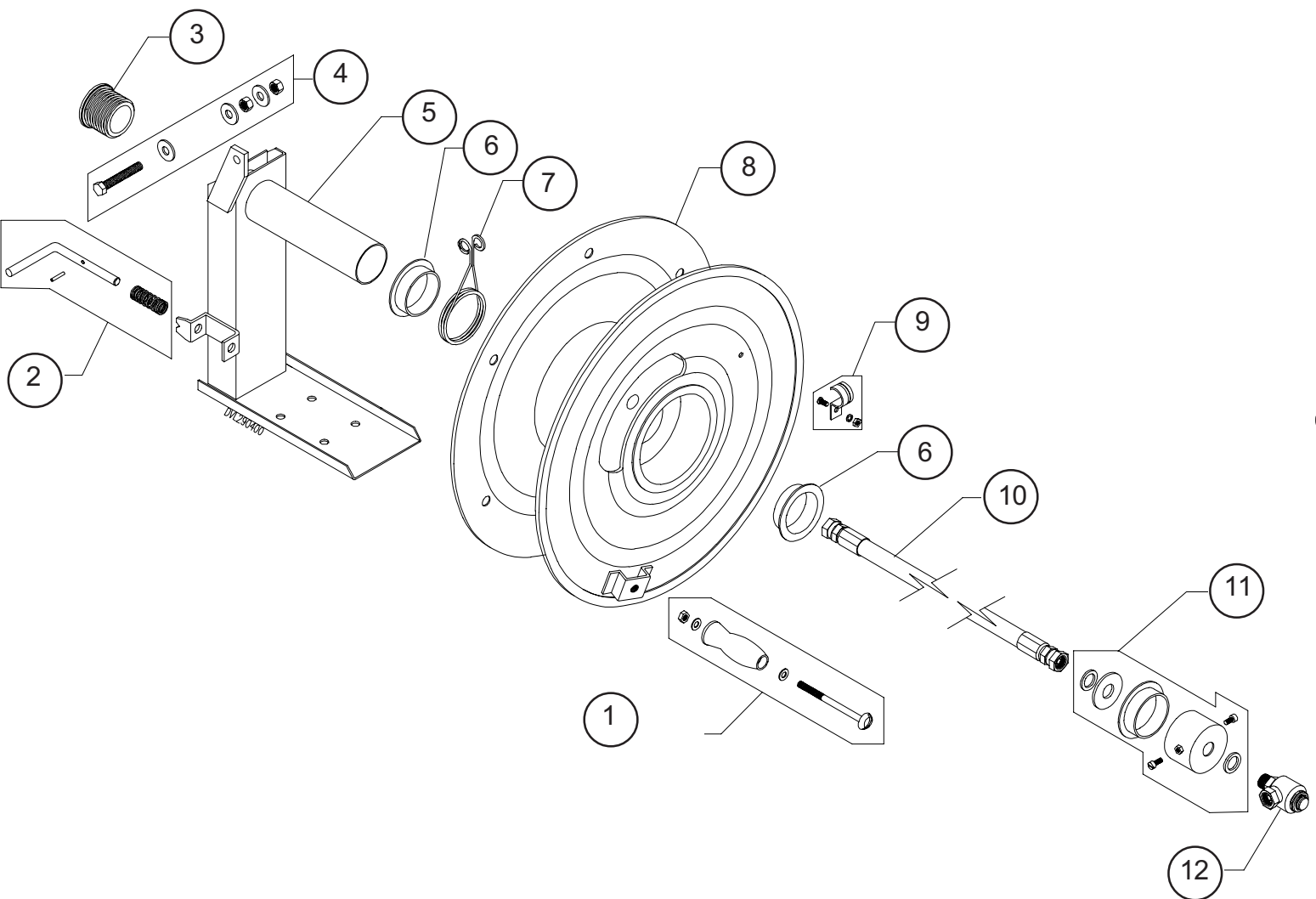

072208

VACASSY751

Hose Reel Assembly

ITEM	QTY	NUMBER	DESCRIPTION
	1	8043927	HOSE REEL, SP 3/8" X 150'
1	1	8043927-1	KIT-HOSE REEL HANDLE W/HARDWARE
2	1	8043927-2	KIT-LOCKING LATCH AND SPRING
3	1	8043927-3	KIT-HOSE GUIDE
4	1	8043927-4	KIT-SCREW, WASHER, BOLT SET
5	1	8043927-5	KIT-BASE
6	1	8043927-6	KIT-BUSHINGS (2)
7	1	8043927-7	KIT-BREAKING SPRING
8	1	8043927-8	KIT-REEL
9	1	8043927-9	KIT-HOSE CLAMP AND SCREW SET
10	1	8042412	HOSE VAC ASSY 6-33 ST-ST FNPT
11	1	8043927-11	KIT-SWIVEL MOUNTING COLLAR
12	1	8043927-12	KIT-3/8" HIGH PRESSURE SWIVEL 5000 PSI

Trailer Assy 599LE

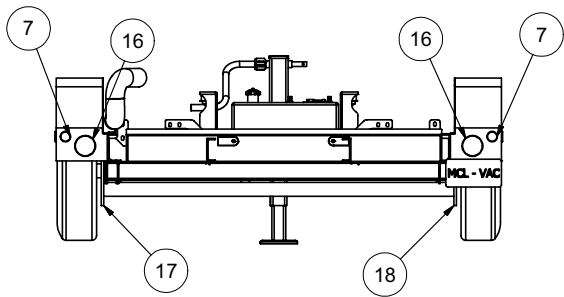
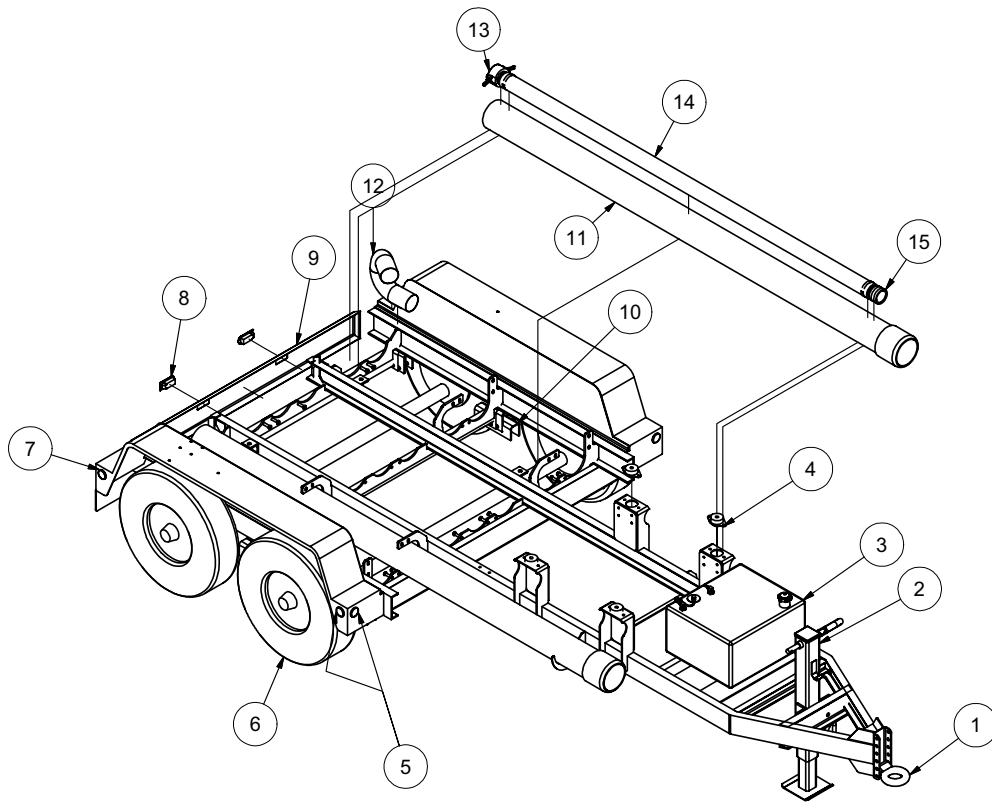

Trailer Assy 599LE

ITEM	QTY	PART #	DESCRIPTION
1	1	8043980	PINTLE EYE
2	1	8043637	JACK - MANUAL
	1	8043984	JACK - HANDLE
3	1	8042380	FUEL TANK 22 GAL
	1	8043359	STRAP W/ EYEBOLT
	1	8042380-1	FUEL TANK CAP
	1	8041725	FUEL SENDING UNIT
	1	8041725-1	SENDING UNIT GASKET
	1	8045686	FUEL LINE SUPPLY 30"
	1	8040965	FUEL LINE RETURN - FILTER TO TANK 58"
4	4	8030904	ISOLATOR 840LB
	4	U000560	SCREW, HC 3/8" - 16 X 3"
	4	8030389	WASHER, SNUBBLING
	4	U120110	NUT, LOCK 3/8" - 16
	8	U000420	SCREW, HC 3/8" - 16 X 1"
	24	U200060	WASHER, FLAT 3/8"
	8	U210060	WASHER, LOCK 3/8"
	8	U100060	NUT, HEX 3/8" - 16
5	4	8044000	2" YELLOW MARKER LIGHT
	4	8044002	2" RUBBER GROMMET
6	4	8046530	TIRE, ST225 75 R15
	4	8046531	WHEEL, R15 X 6
	2	8045897	AXLE, LE
	4	8045898	HUB
	24	8043987	LUG NUTS
	4	8043988	GREASE CAP
	4	8043989	GREASE CAP PLUG
7	4	8043999	2" RED MARKER LIGHT
	4	8044002	2" RUBBER GROMMET
8	2	8040586	SEALED LEVER LATCH
9	1	8045756	TAILGATE 599LE
10	4	8045899	SPRING
	8	8045900	U-BOLT
	8	8045901	U-BOLT NUT
	4	8045902	TIE PLATE
11	2	8041102	HOSE STORAGE 6" X 10'
	2	8030925	END CAP 6"
	2	8041485	LANYARD CABLE
	4	8040959	HOSE STORAGE CLAMP
	8	U200060	WASHER, FLAT 3/8"
	8	U100060	NUT, HEX 3/8"
12	1	8046262	EXHAUST ELBOW TANK PIVOT 4"
13	2	8046441	CAMLOCK, 3" AL FCAM X MBARB
14	2	8040338	HOSE VAC KANAFLEX 3 - 110"
15	2	8046440	CAMLOCK, 3" AL MCAM X MBARB
16	2	8044001	4" STOP/TURN LIGHT
	2	8044003	4" RUBBER GROMMET
17	1	8046307	LH BRAKE ASSEMBLY
	2	8046304	MAGNET KIT
	2	8046305	SHOE KIT
	1	8046306	ADJUSTER KIT
18	1	8046308	RH BRAKE ASSEMBLY
	2	8046304	MAGNET KIT
	2	8046305	SHOE KIT
	1	8046306	ADJUSTER KIT
*	NOT SHOWN		
*	1	8043981	SAFETY CHAIN
*	1	8043982	BREAKAWAY SWITCH
*	1	8044007	6-WAY PLUG

Skid Assembly

V500LE

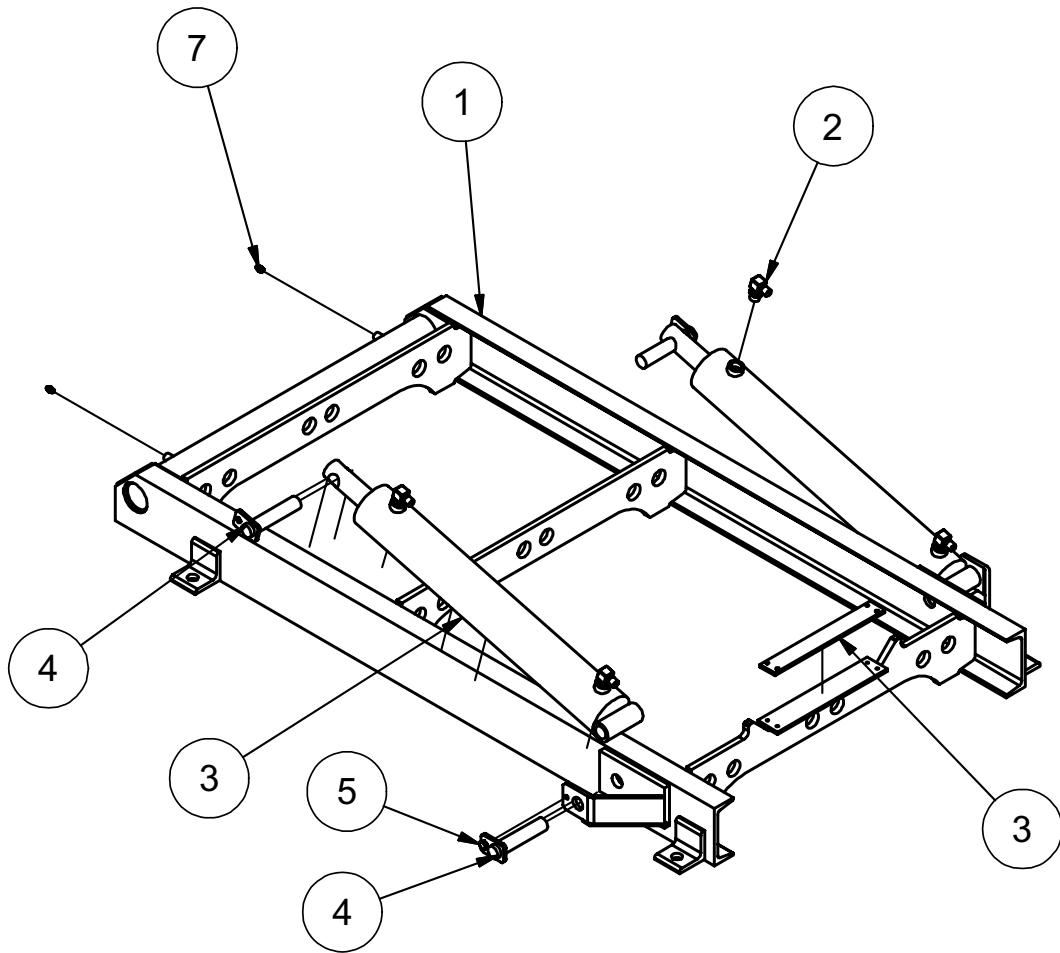

Skid Assembly

V500LE

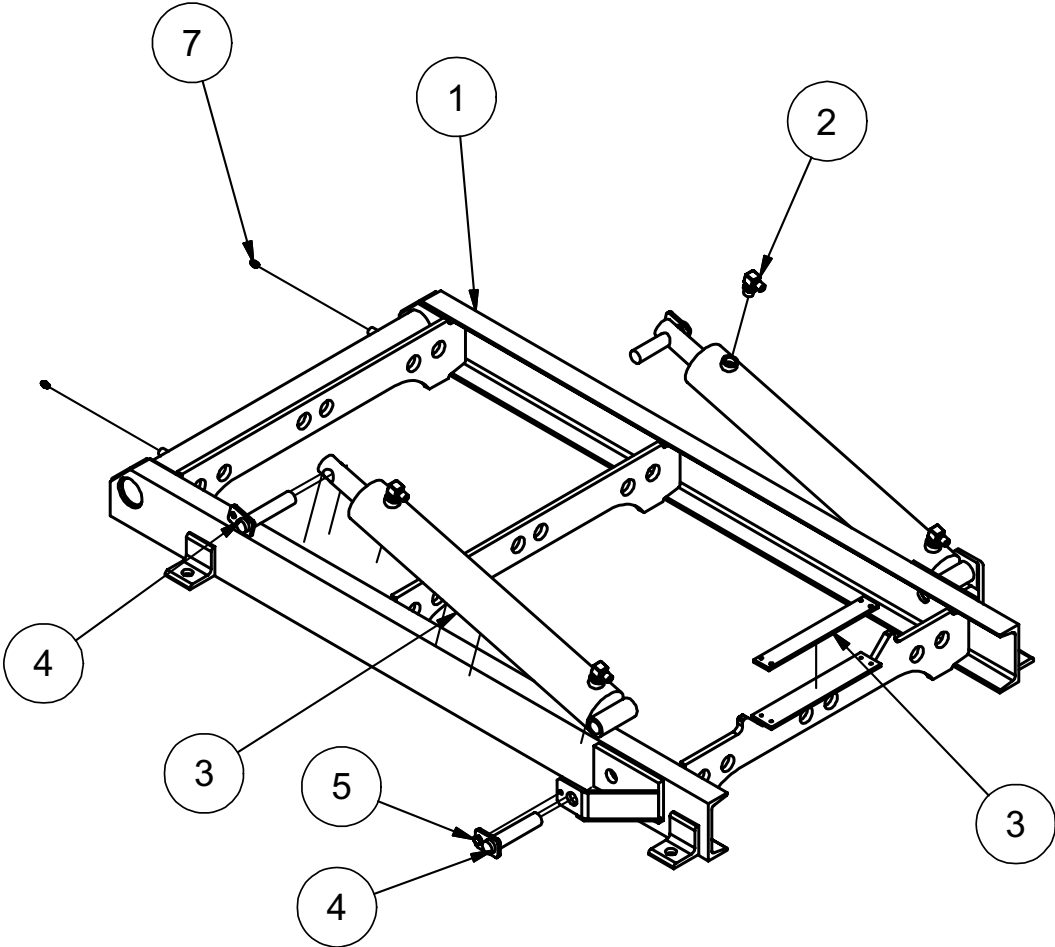

Hydraulic Jack Option

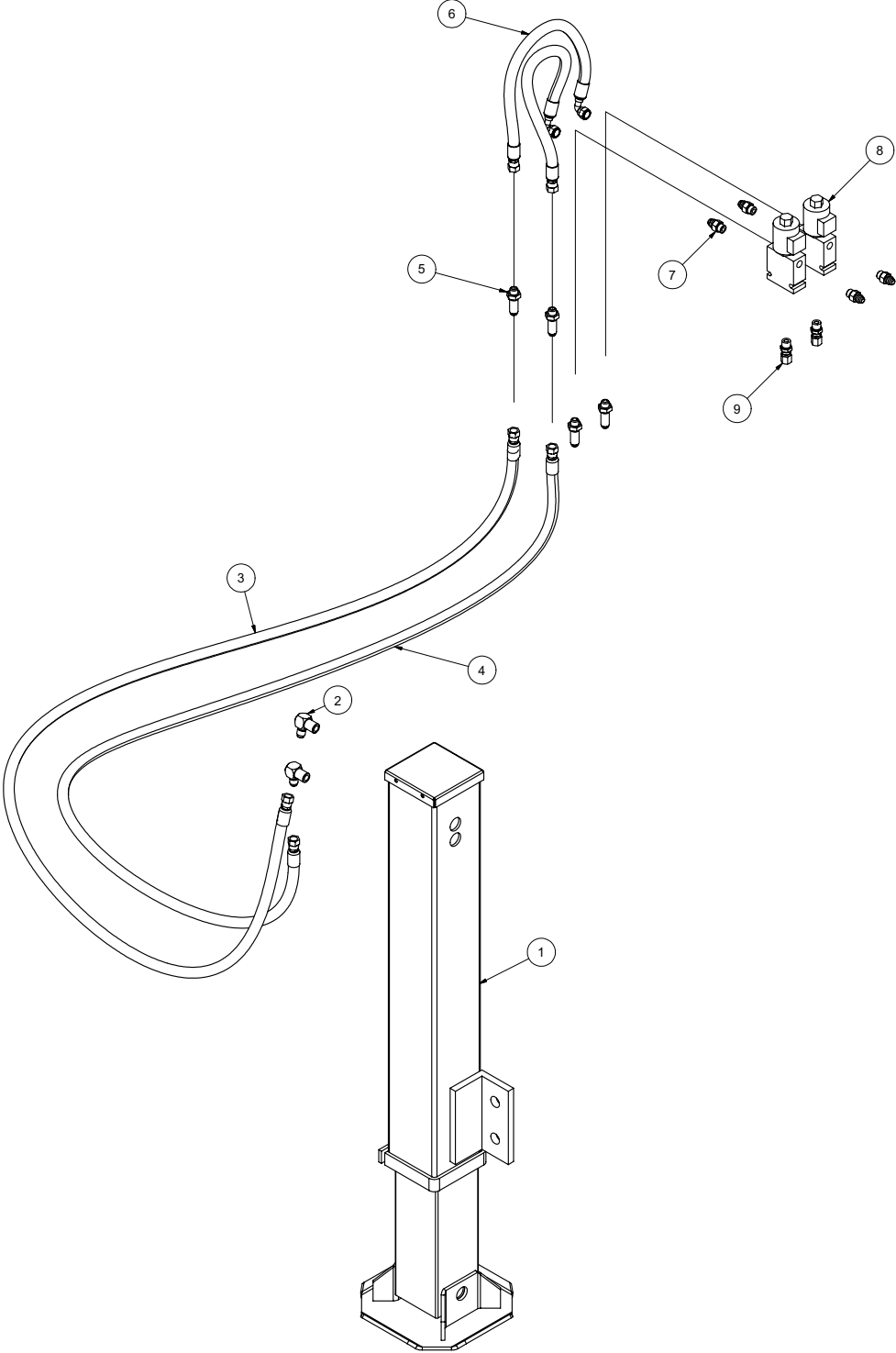

Hydraulic Jack Option

ITEM	QTY	PART #	DESCRIPTION
1	1	8043653	HYDRAULIC JACK CYLINDER
2	2	T401103	ELBOW 90 DEG 3/8"MJ - 1/4"FJ
3	1	8042661	HOSE ASSY VAC 6-66 ST-90
4	1	8041442	HOSE ASSY VAC 6-60 ST-90
5	2	T400391	BULKHEAD, 3/8"MJ - 3/8"MJ
6	2	8040973	HOSE ASSY VAC 6-20 ST-90
7	4	T400037	UNION, 3/8"MB - 3/8"MJ
8	2	8041788	SOLENOID VALVE
9	2	8030512	UNION, 3/8"MB - 3/8"FJ
*	1	X000274	SWITCH ROCKER DPDT

* NOT SHOWN

Surge Brake Option

V500

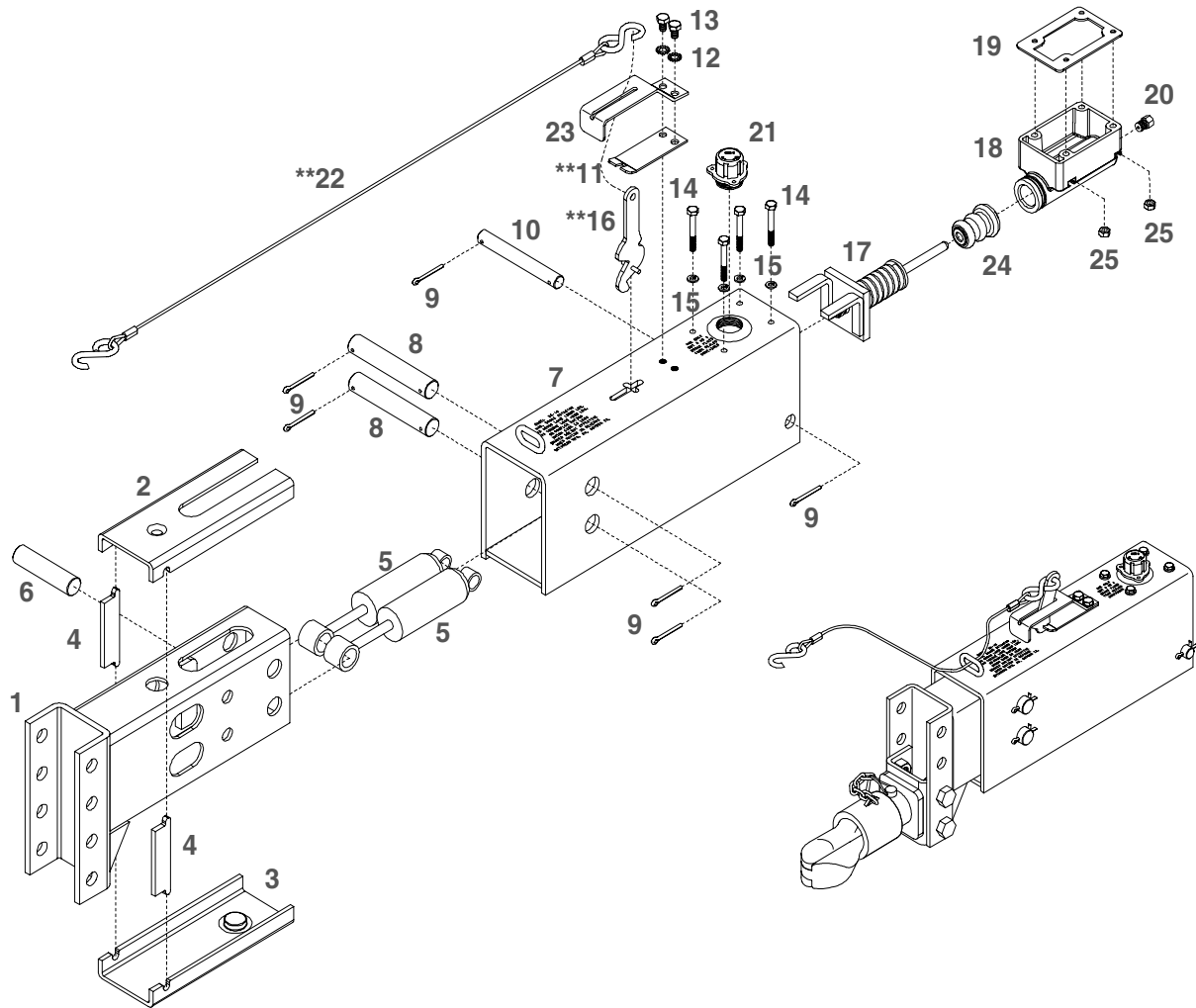

Surge Brake Option

V500

ITEM	QTY	NUMBER	DESCRIPTION
1	1	8040790-1	INNER SLIDER TUBE CHAN. DOWN
2	1	8040790-2	TOP WEAR PAD
3	1	8040790-3	BOTTOM WEAR PAD
4	2	8040790-4	SPACER BLOCK
5	2	8040790-5	DAMPER SHOCK
6	1	8040790-6	FRONT SHOCK PIN (ZINC PLATED)
7	1	8040790-7	OUTER CASE
8	2	8040790-8	CONNECTING PIN (ZINC PLATED)
9	6	8040790-9	5/32" X 1-1/4" COTTER PIN
10	1	8040790-10	REAR SHOCK PIN (ZINC PLATED)
11	1	8040790-11	EMERGENCY LEVER SPRING (ZINC PLATED)
12	2	8040790-12	5/16" EXTERNAL TOOTH LOCK WASHER
13	2	8040790-13	5/16"-18 UNC X 5/8" HEX HEAD BOLT GR.5
14	4	8040790-14	1/4"-20 UNC X 2" HEX HEAD BOLT GR.5
15	4	8040790-15	1/4" LOCK WASHER
16	1	8040790-16	EMERGENCY LEVER (ZINC PLATED)
17	1	8040790-17	PUSH ROD ASSEMBLY
18	1	8040790-18	COMPOSITE MASTER CYLINDER (DRUM BRAKES)
19	1	8040790-19	REPLACEMENT MASTER CYL. GASKET ONLY
20	1	8040790-20	1/8" PIPE-3/16" FITTING W/ORIFICE (DRUM)
21	1	8040790-21	MASTER CYLINDER CAP W/DIAPHRAGM AND O-RING
22	1	8040790-22	3/32" CABLE WITH HOOKS (BOTH ENDS)
23	1	8040790-23	LEVER GUIDE (ZINC PLATED)
24	1	8040790-24	MASTER CYL. PROTECTIVE BOOT
25	4	8040790-25	1/4"-20 UNC HEX NUTS

Tool Rack Assembly

LEHD

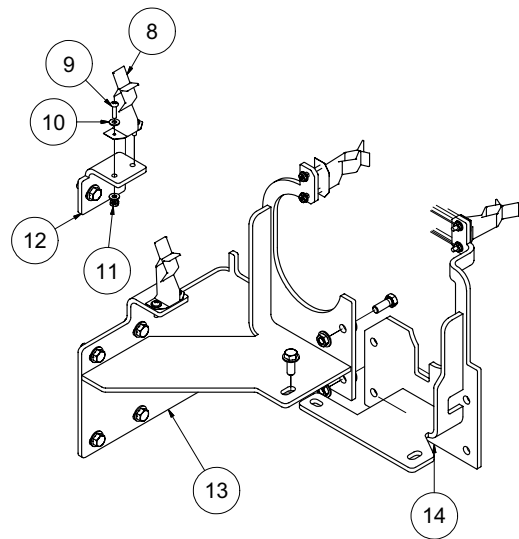
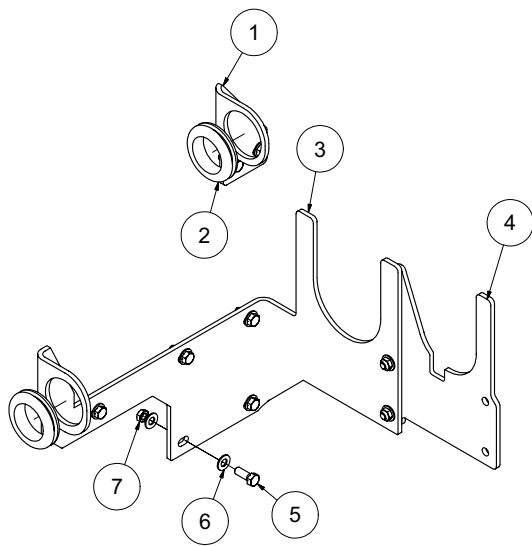

Tool Rack Assembly

LEHD

ITEM	QTY	PART NO.	DESCRIPTION
1	1	8046209	TOOL RACK BRACKET #3
2	2	8042812	GROMMET 2" ID 1/4" WOG
3	1	8046208	TOOL RACK BRACKET #2
4	1	8046217	TOOL RACK EXTRA TOOL BRACKET
5	18	U000420	SCREW, HC 3/8"-16 X 1.00
6	36	U200600	WASHER, FLAT 3/8"
7	18	U120110	NUT, HEX LOCK 3/8"
8	4	8040899	CLIP, TOOL HOLDER
9	8	C400119	SCREW, PHILLIPS 10 - 24 X 3/4"
10	16	U200001	WASHER, FLAT #10
11	8	U100010	NUT, HEX 10 - 24
12	1	8046207	TOOL RACK BRACKET #1
13	1	8046206	TOOL RACK WELDMENT LE #1
14	1	8046210	TOOL RACK EXTRA TOOL WELDMENT

Tools (Option)

Reduction Tool STD

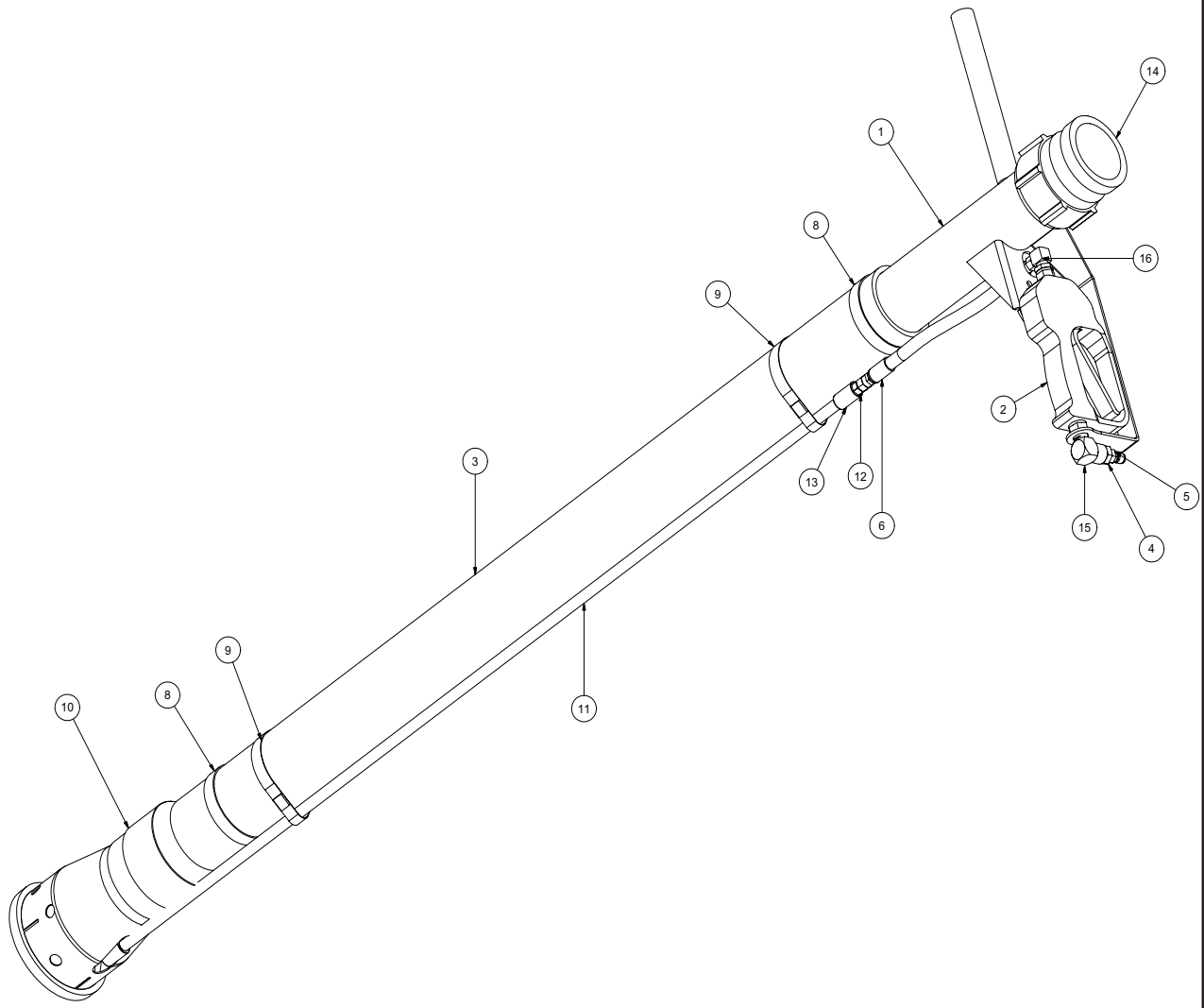

Tools(Optional)

Reduction Tool STD

ITEM	QTY	PART NO.	DESCRIPTION
-	-	8043115	TOOL VAC REDUCTION STD COMPLETE
1	1	8042862	TOOL VAC HEAD ASSY 3"
2	1	8042026	STRAIGHT SPRAY GUN
3	1	8042811	TOOL VAC REDUCTION PVC 3" X 48"
4	1	T400023	UNION 6MP 4FP
5	1	8030486	WATER QD 1/4 MNPT SS
6	2	T320030	FITTING, HOSE 4HO 4FJ
7	1	8031278	HOSE ASSEMBLY REDUCTION TOOL
8	2	8042605	CLAMP HOSE T BOLT 350
9	2	8042855	CLAMP HOSE T BOLT 375
10	1	8030627	TOOL VAC REDUCTION LOWER ASSY
11	1	8043764	VAC WATER SUPPLY TUBE CHROME 1/4NPT
12	1	T400020	UNION 1/4" MP-1/4" MJ STRAIGHT
13	1	8030367	VAC FITT 1/4" FF-S
14	1	8030391	BANJO 3" MALE 3" FNPT
15	1	T401065	ELBOW, 3/8 MP - 3/8 FP
16	1	T401100	ELBOW 4MP 4MJ 90
*	2	8030370	REDUCTION TOOL NOZZLE
*	2	8031268	REDUCTION TOOL NOZZLE 45 DEG

* NOT SHOWN

Tools

3" Suction Tool

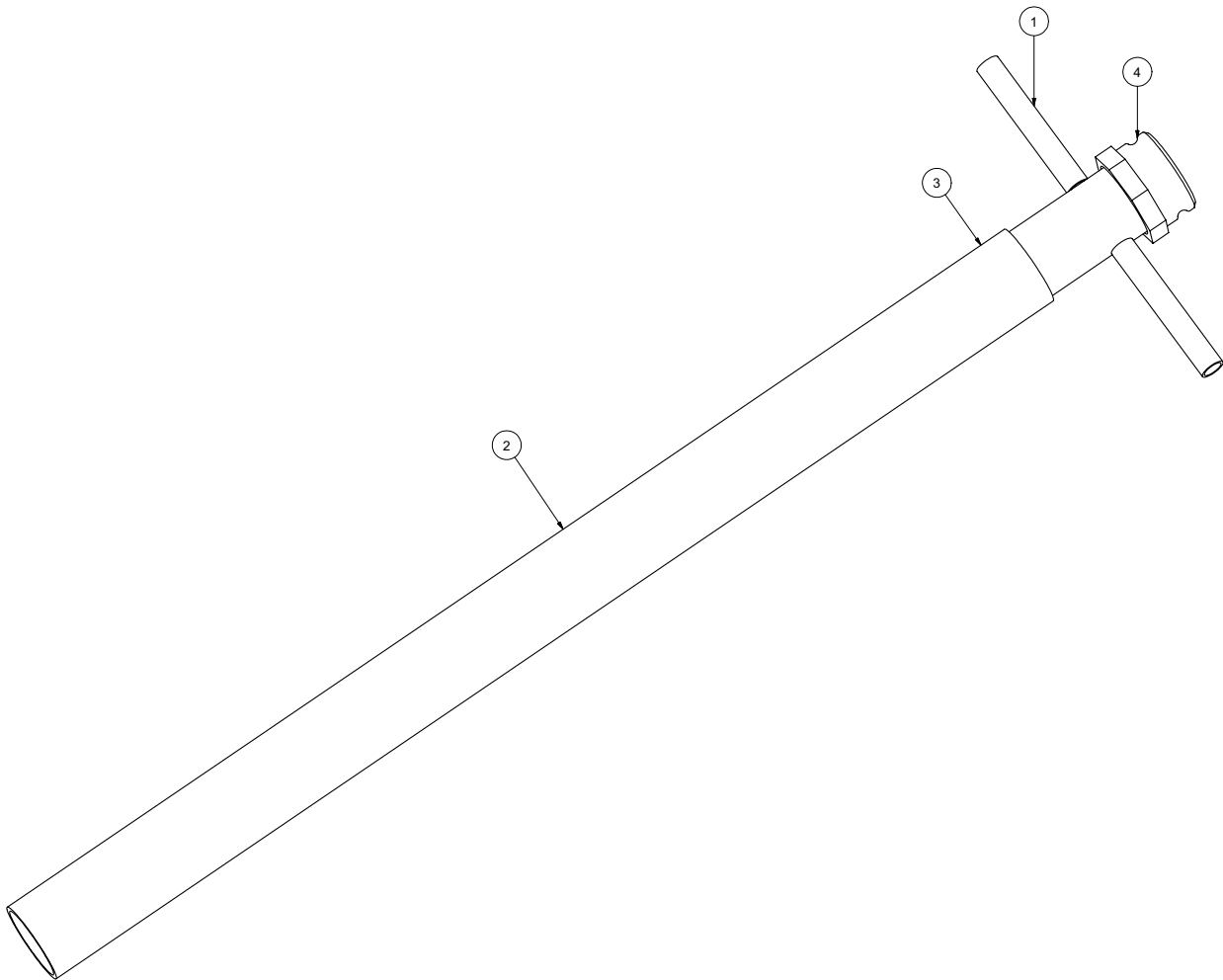

Tools

3" Suction Tool

ITEM	QTY	NUMBER	DESCRIPTION
	1	8030215	TOOL VAC SUCTION 3" COMPLETE
1	1	8030317	TOOL VAC HANDLE ASSEMBLY 3"
2	1	8030313	PVC VACUUM TUBE 3"
3	1	8030356	CLAMP,4"PUNCHLOCK P16-S
4	1	8030391	COUPLING, 3" BANJO

Tools

Wash Wand

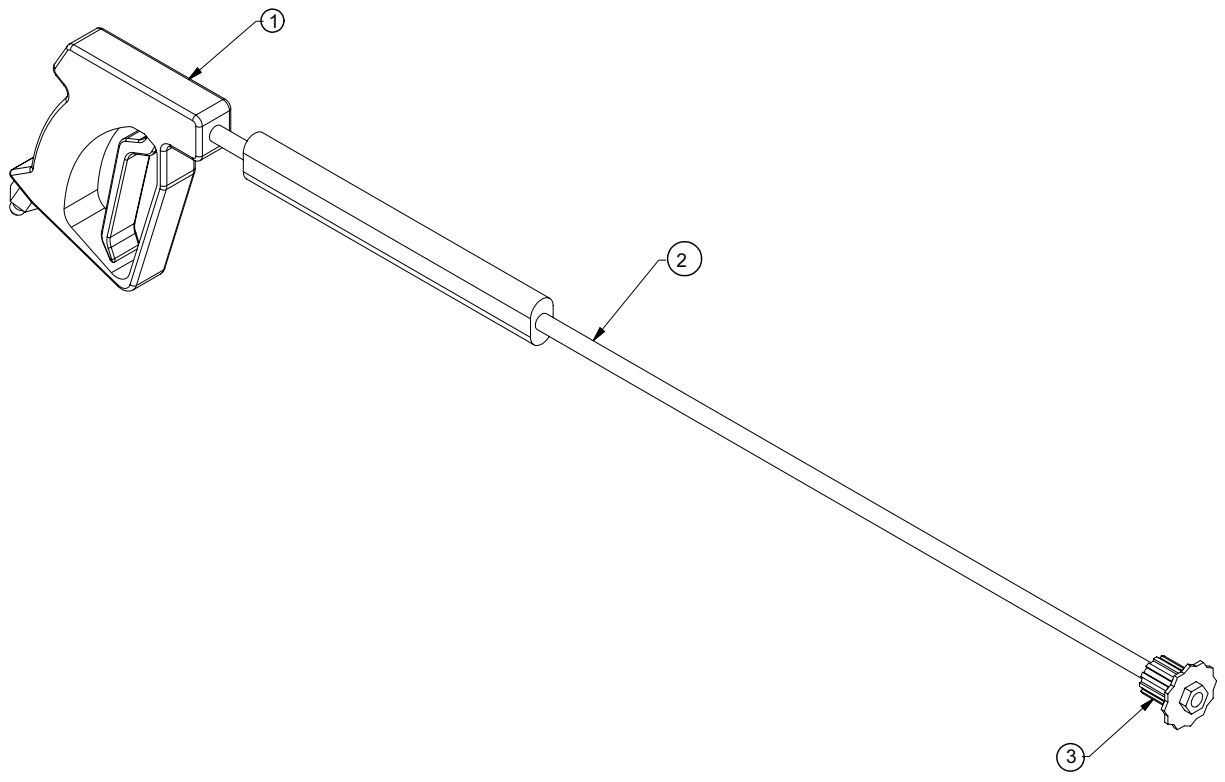

Tools

Wash Wand

Item	Qty	Number	Description
1	1	8030348	TOOL VAC SPRAY WAND COMPLETE
2	1	8030928	TRIGGERASSEMBLY
3	1	8030847	WAND
		8031308	NOZZLE,#6 40 DEGREE FOR WAND

Valve Box Cleanout Tool

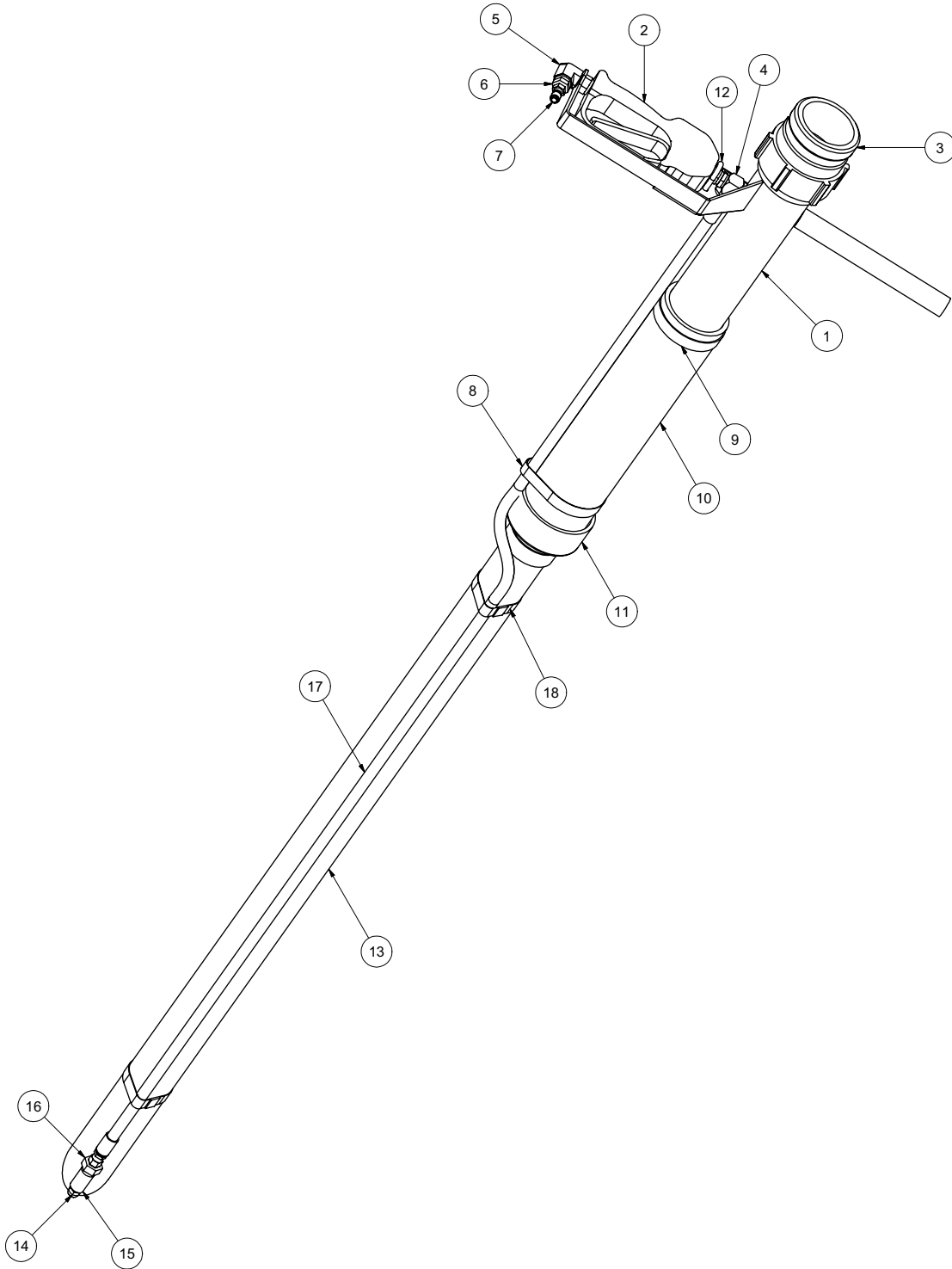

050709

VACASSY714

Valve Box Cleanout Tool

ITEM	QTY	PART NO.	DESCRIPTION
1	1	8042862	REDUCTION TOOL HEAD WELD'T
2	1	8042026	STRAIGHT SPRAY GUN
3	1	8030391	BANJO 3" MALE FNPT
4	1	T401100	ELBOW 4MP 4MJ 90
5	1	T401065	ELBOW, 3/8 MP - 3/8 FP
6	1	T400023	REDUCER 6MP 4FP
7	1	8030486	WATER QD 1/4 MNPT SS
8	1	8042855	CLAMP HOSE T-BOLT 375
9	1	8042605	CLAMP HOSE T-BOLT 350
10	1	8044096	PVC 3" DIA X 9" LONG
11	1	8030669	REDUCER PVC 3" TO 2" SLIP ON
12	1	U010019	U-BOLT 1_4-20 X 3_4 WIDE X 2 1_4 LONG
13	1	8044097	PVC 2" DIA X 42.5" LG
14	1	8031246	NOZZLE, .100 X 0 DEG
15	1	T422010	COUPLING 1/4"FP
16	1	U400020	UNION, 1/4" MP - 1/4" MJ
17	1	8044098	HOSE ASSY VALVE BOX CLEANOUT TOOL
18	2	8045316	CLAMP, HOSE T-BOLT 275

Tools

Rotary Lance

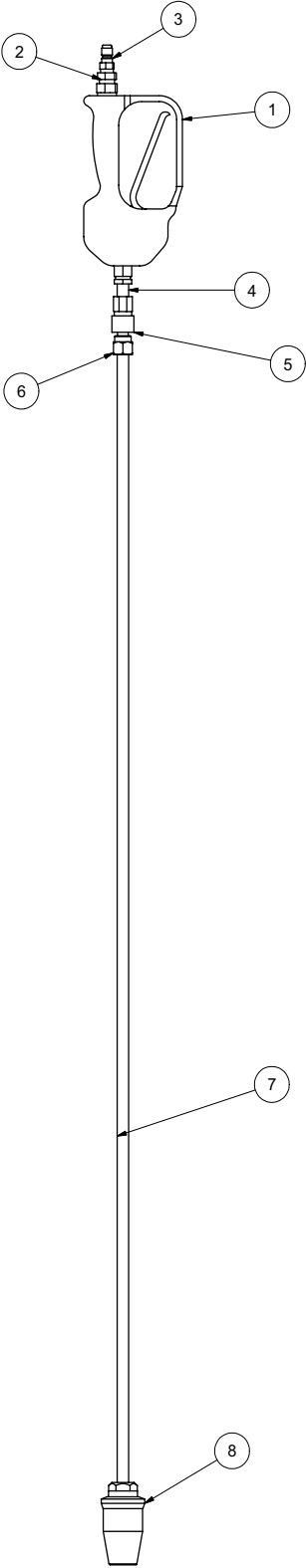

Tools

Rotary Lance

ITEM	QTY	PART NO.	DESCRIPTION
1	1	8042026	STRAIGHT SPRAY GUN
2	1	T400023	UNION 6MP-4FP
3	1	8030486	WATER QD 1/4MNPT SS
4	1	T421010	NIPPLE, CLOSE 1/4"
5	1	8030526	FITTING, QD WATER 1/4F - 1/4"FP
6	1	8030487	WATER QD 1/4 FNPT SS
7	1	8043764	47 INCH LANCE EXT. 1/4NPT X 1/4NPT
8	1	8042691	ROTARY WOBBLE NOZZLE 90

Tools

Lawn Sweeper 3''

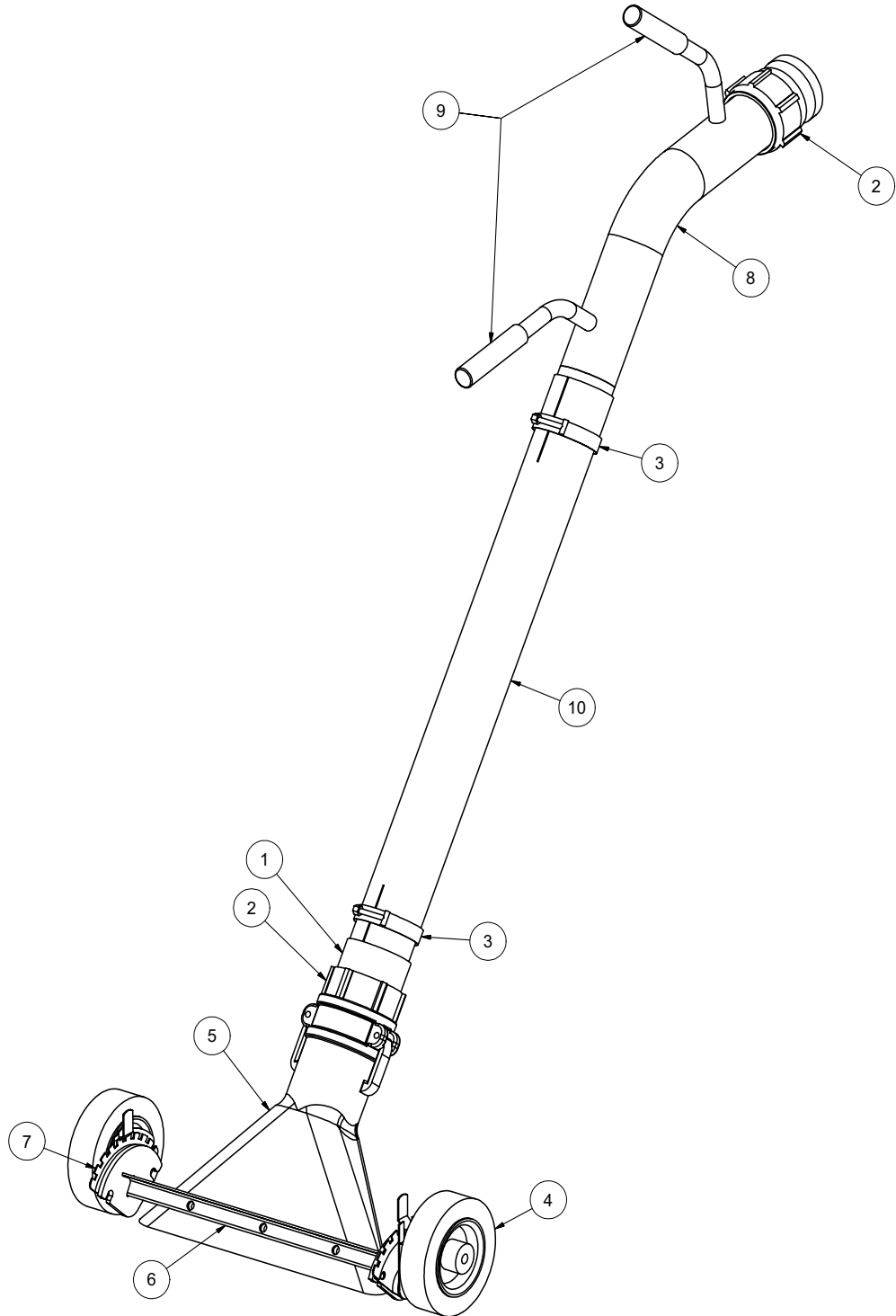

071708

VACASSY713

Tools

Lawn Sweeper 3"

ITEM	QTY	PART #	DESCRIPTION
1	1	8030287	3" HOSE X 3" MNPT ADAPTER
2	2	8030391	BANJO 3" MALE 3" FNPT
3	2	8042605	CLAMP T-BOLT 3" (350)
4	2	8043887	WHEEL 6" PNEUMATIC
5	1	8043925	DUCKBILL 3" ALUMINUM
6	1	8043928	LS WHEEL WELDMENT
7	1	8043931	WHEEL ADJUSTERS (1 LEFT/1 RIGHT)
8	1	8043933	LS HANDLE WELDMENT
9	2	J300080	HANDLE GRIP
10	1	8043932	PVC 3" X 30"

Surface Cleaner

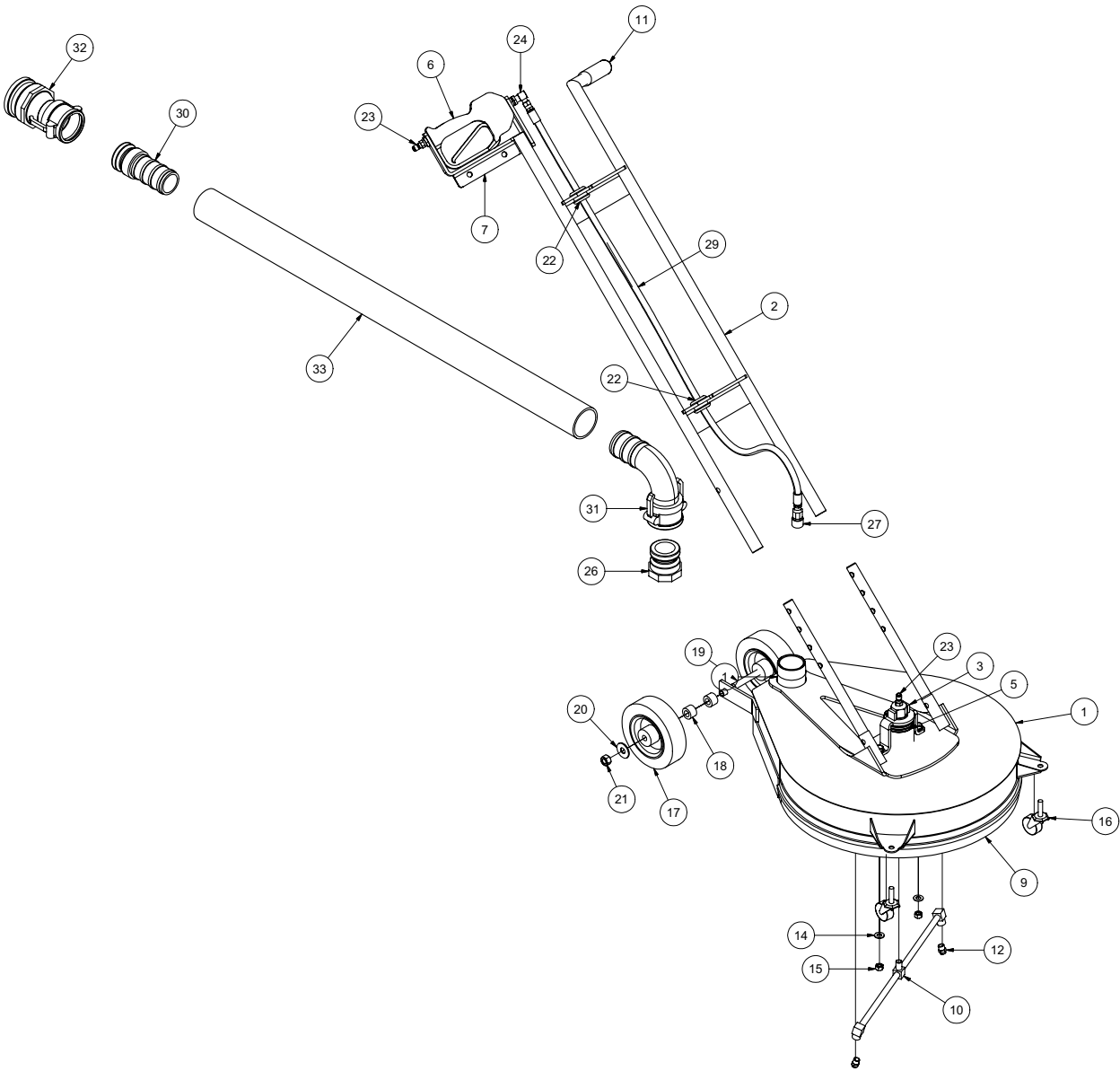

Surface Cleaner

ITEM	QTY	PART NO.	DESCRIPTION
1	1	8041887	SURFACE CLEANER - HEAD ASSY
2	1	8042019	HANDLE ASSY
3	1	8041890	ROTARY RETAINER
4	2	8042022	HANDLE ADJ. TUBE
5	1	8044102	ROTARY HEAD
6	1	8042026	STRAIGHT SPRAY GUN
7	1	8042020	GUN CAPTURE BRACKET
8	1	8044103	SQUEEGEE
9	1	8044104	FLEXIBLE BRUSH
10	1	8044105	ROTARY ARM
11	1	8044106	GRIP HANDLE
12	2	8031419	NOZZLE, #4.0 25 DEG
13	2	U000420	SCREW, HC 3/8-16 X 1.00
14	4	U200600	WASHER, FLAT 3/8"
15	2	U100060	NUT, HEX 3/8-16
16	2	8044107	SWIVEL CASTER 1 5/8"
17	2	8043887	WHEEL 6" PNEUMATIC
18	2	8043591	SURFACE CLEANER REAR WHEEL SPACER
19	1	U001060	SCREW, HC 1/2-13 X 6.0
20	2	U200100	WASHER, FLAT 1/2"
21	1	U120120	NUT, LOCK 1/2-13
22	2	8041686	GROMMET 1"ID- 1 1/4"DOG-1/4"WO
23	2	8030486	WATER QD 1/4 MNPT SS
24	1	T401100	ELBOW 4MP 4MJ 90
25	1	T320030	FITTING, HOSE 4HO 4FJ
26	1	8043389	ADAPTER M2" F THREAD
27	1	8030526	FITTING, QD WATER 1/4"F-1/4"FP
28	1	T320300	FITTING, HOSE 4HO 4MP
29	1	8044108	HOSE VAC SURFACE CLEANER
30	1	8043392	ADAPTER M2" F THREAD
31	1	8043391	REDUCER COUPLER 2"F 90 DEG - 3"M
32	1	8043395	REDUCER COUPLER 2" X 3" ADAPTER
33	1	8043398	HOSE VAC CLEAR 2"
*	2	8043397	CLAMP VAC CLEAR HOSE 2"
*	4	U360020	PIN, U-LOCK 3/8 X 1.5

EXTENSION ARM

BOOM

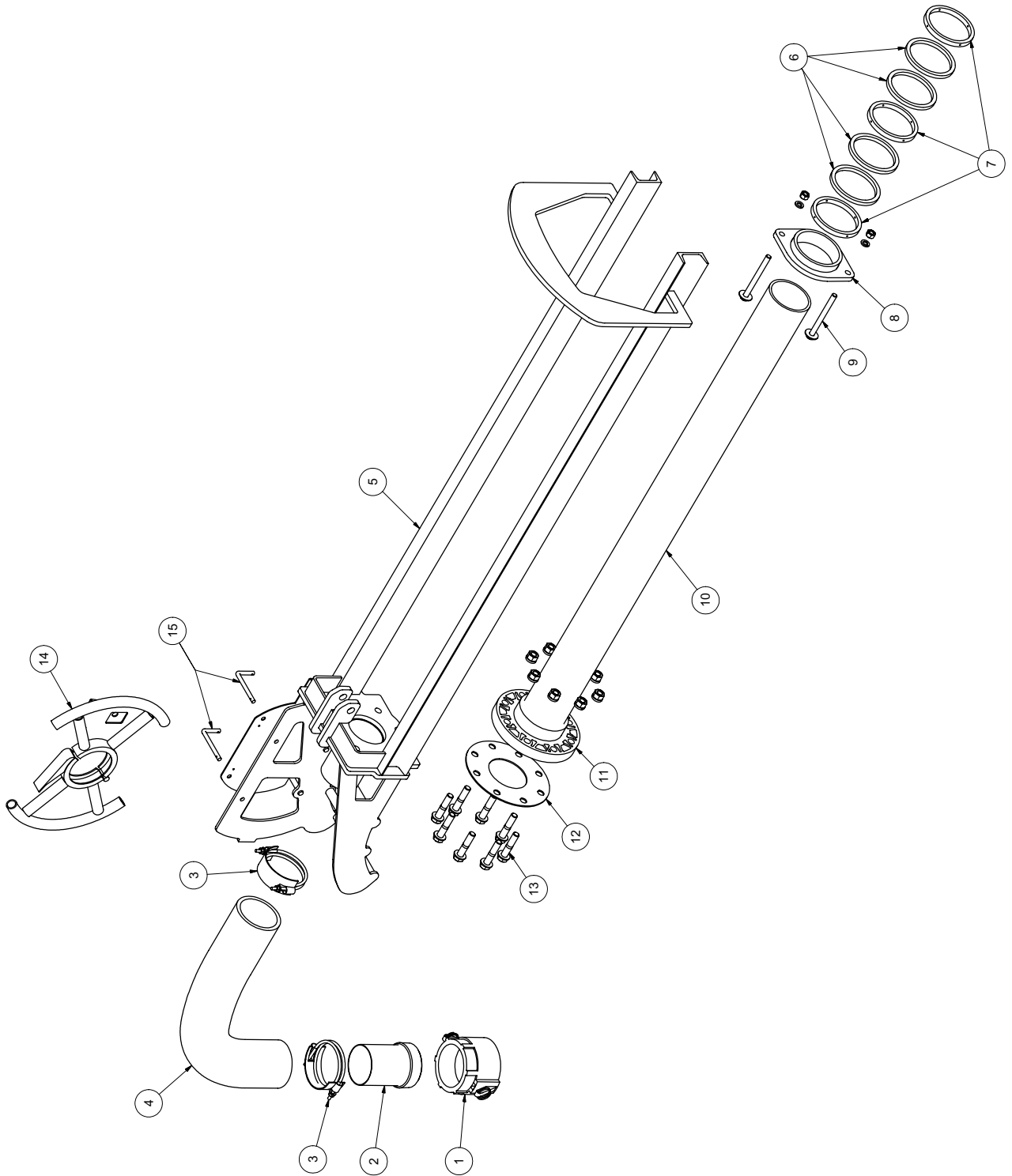

EXTENSION ARM

BOOM

ITEM	QTY	NUMBER	DESCRIPTION
1	1	8030846	4" FEMALE COUPLER
2	1	8045239	UNION EXHAUST 4" OD-MNPT
3	2	8042606	CLAMP T-BOLT 450
4	1	8045800	HOSE VAC AG SUCTION 4-18
5	1	8041960	EXTENSIONARM
6	4	8041947	PACKING RING
7	3	8041945	PLASTIC SLEEVE
8	1	8041963	PACKING GLAND
9	2	U001020	SCREW HC 1/2-13 X 5.50
	2	U200100	WASHER FLAT 1/2"
	2	U210100	WASHER LOCK 1/2"
	2	U100120	NUT HEX 1/2-13
10	1	8042160	4" PVC TUBE X 60" LONG
11	1	8041937	4" PVC FLANGE
12	1	8041938	GASKET
13	8	U001250	SCREW HC 5/8-11 X 3.00
	8	U200140	WASHER FLAT 5/8"
	8	U210140	WASHER LOCK 5/8"
	8	U100180	NUT HEX 5/8-11
14	1	8043647	BOOM HANDLE
	2	8042971	RUBBER STRIP
15	2	8043947	CAPTURE PIN
	2	R700160	R CLIP
	2	8041485	LANYARD CABLE

PIVOT ARM

BOOM

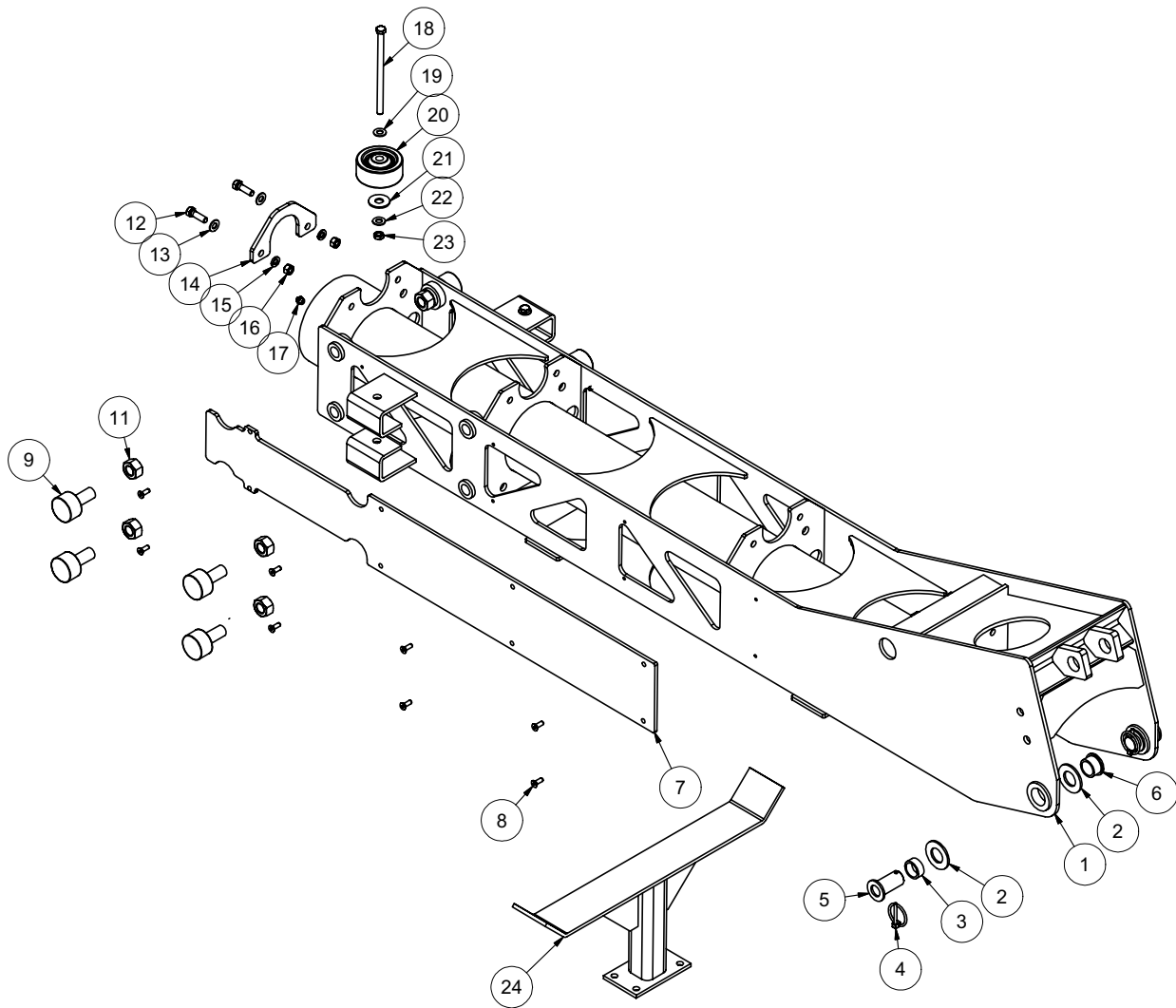

PIVOT ARM

BOOM

ITEM	QTY	NUMBER	DESCRIPTION
1	1	8041950	PIVOT ARM
2	6	U200170	WASHER FLAT 1.0"
3	2	8042101	BUSHING BRONZE 1.25"X1.00"X0.50" PLN
4	10	U340050	PIN LINCH 3/16 X 1-9/16
5	2	8042124	PIN
6	2	8041883	BUSHING BRONZE 1.25"X1.00"X0.63" FLG
7	2	8041986	GLIDE SHEET
8	16	U030015	SCREW SFH .250-20 X .750
9	8	W000050	ROLLER
11	8	U120151	NUT,JAM NYLON LOCK .750-16
12	12	U000440	SCREW HC .375-16 X 1.25
13	2	U200600	WASHER FLAT 3/8"
14	1	8041956	CYLINDER RETAINER
15	2	U210060	WASHER LOCK 3/8"
16	2	U100060	NUT HEX .375-16
17	1	T500100	GREASE FITTING
18	2	U001040	SCREW HC .500-13X6.50
19	2	U200100	WASHER FLAT 1/2"
20	2	8030226	WHEEL
21	2	U200100	WASHER FLAT 1/2"
22	2	U200100	WASHER FLAT 1/2"
23	2	U120120	NUT LOCK .500-13
24	1	8044560	CRADLE, V500 (11 1/4")
	1	8043769	CRADLE, V800-V1200 (8 3/8")

TURRET

BOOM MANUAL ROTATION

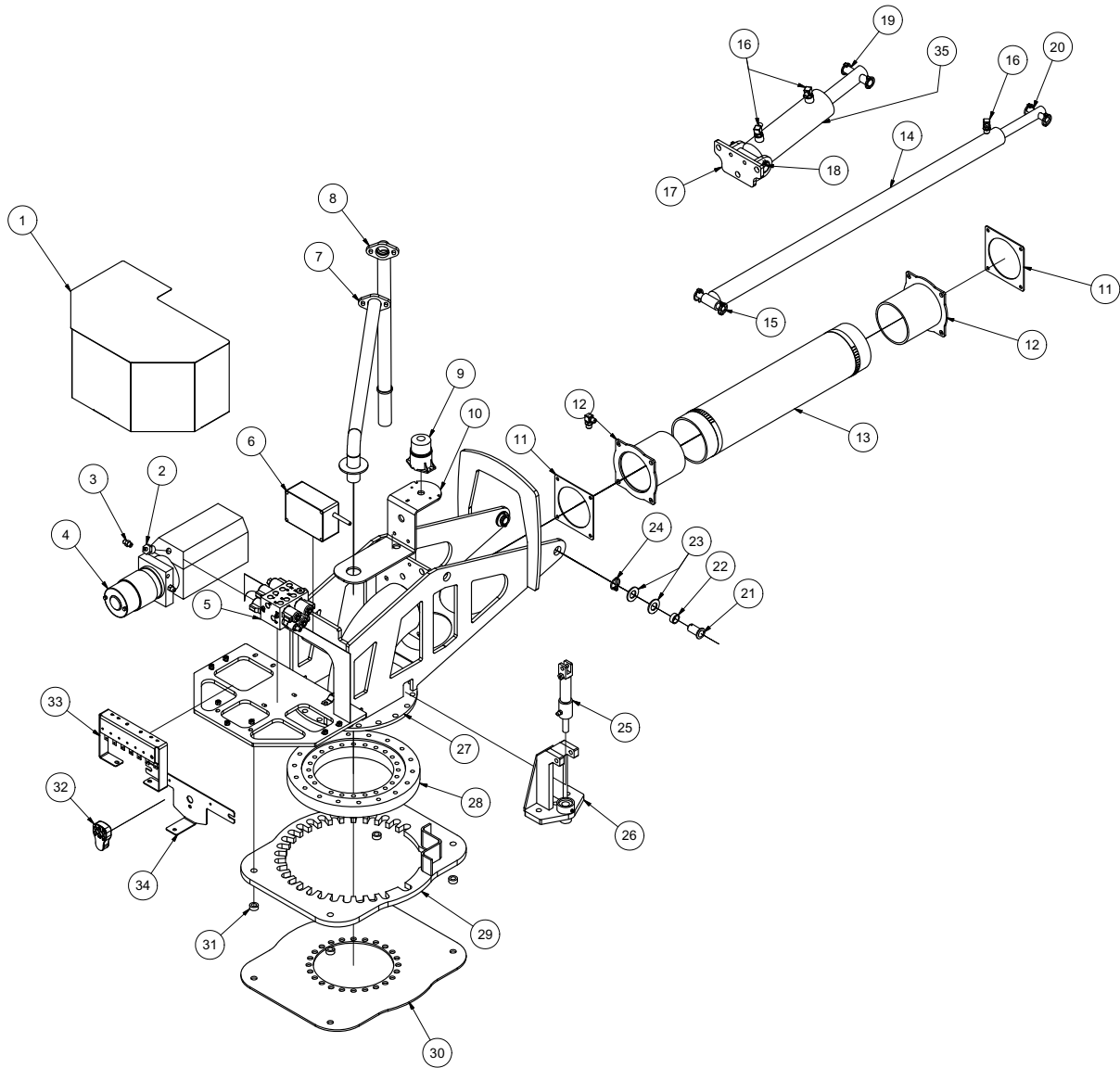

TURRET

BOOM MANUAL ROTATION

ITEM	QTY	PART #	DESCRIPTION	PORT	PART#	DESCRIPTION	USED ON
1	1	8043090	BOOM GUARD				
2	1	T403018	REDUCER 12MP-4MJ				
3	2	T400037	UNION 6MB-6MJ				
4	1	8041601	PUMP HYD. 12V 6QT				
5	1	8043578	MANIFOLD ASSY BOOM				
6	1	8041914	BOOM - RC RECEIVER 6-RELAY				
*		8042427	BOOM - RC RECEIVER 8-RELAY				
7	1	8043245	BOOM CABLE TUBE WELDMENT				
8	1	8045080	BOOM CABLE TUBE VERTICAL WELDMENT				
9	1	8043139	STROBE LIGHT				
10	1	8041932	BOOM - TURRET STROBE LIGHT PLATE				
11	2	8041988	BOOM - FLANGE GASKET				
12	2	8041958	BOOM - FLEX HOSE ADAPTER WELDMENT				
13	1	8043678	HOSE AG SUCTION 6-30				
	2	8042104	HOSE CLAMP 6IN T-BOLT				
14	1	8030359	CYLINDER, HYD. 3" X 20" VAC'S				
	1	8043782	HYD. HOSE EXTEND 6-77 ST-90	1.1	8043584	3-WAY VALVE	ALL
	1	8043783	HYD. HOSE RETRACT 6-114 ST-90	1.2	8043584	3-WAY VALVE	ALL
15	1	8042122	BOOM - EXT. CYLINDER BASE PIN	1.3	8043584	3-WAY VALVE	ALL
	2	U340050	PIN LINCH 3/16 X 1 9/16"	1.4	8043584	3-WAY VALVE	ALL
16	4	T401270	ELBOW, 90 1/2"MB - 3/8"MJ	3.2	8043586	CHECK VALVE	MANUAL ROTATION
17	1	8042887	AJUSTABLE CLEVIS - BOOM	4.2	8042302	PRESSURE SWITCH	MANUAL ROTATION
18	1	8041977	BOOM - PIVOT CYLINDER BASE PIN			1000 PSI, N/C	
	2	U340050	PIN LINCH 3/16 X 1 9/16"	5	8043587	RELIEF VALVE ADJ	ALL
19	1	8041990	BOOM - PIVOT CYLINDER ROD PIN	7	8043585	2-WAY VALVE N/O	MANUAL ROTATION
	2	U340050	PIN LINCH 3/16 X 1 9/16"				
20	1	8042350	BOOM - EXT. CYLINDER RD PIN				
	2	U340050	PIN LINCH 3/16 X 1 9/16"				
21	2	8042124	BOOM - TURRET PIVOT PIN				
22	2	8042101	BUSHING BRONZE 1.25" X 1.00" X .50"LG				
23	4	U200170	WASHER, FLAT 1"				
24	2	U340050	PIN LINCH 3/16 X 1 9/16"				
25	1	8043052	BRAKE CYLINDER				
	1	T400801	PLUG, BREATHER 1/4"NPT				
	1	T402020	UNION 4MJ-4MP				
26	1	8045157	BOOM MANUAL BRAKE WELDMENT				
	1	T500080	FITTING, GREASE 3/16"				
27	1	8042240	BOOM - TURRET WELDMENT				
	2	8041686	GROMMET 1"ID - 1 1/4"DOG - 1/4"WO				
	6	U001281	SCREW, HC .625 - 11 X 3.50"				
	6	U120020	NYLON LOCK NUT .625-11				
	12	U200140	WASHER FLAT .625				
28	1	8042234	SWIVEL BEARING				
*	3	T500020	FITTING,GREASE.125 STRAIGHT (2 FITTINGS IN INNER RING, 1 IN OUTER RING)				
29	1	8045195	BOOM MOUNT BRAKE RING				
30	1	8043021	BOOM - LOWER STOP DISC				
31	4	8030315	SKID - WATER TANK CLEVIS TUBE				
32	1	8042426	RC TRANSMITTER (w/ GRAPHIC OVERLAYS)				
*	1	X200006	BOOM WIRING HARNESS				
*	1	8041911-1	RUBBER 6-BUTTON PAD				
*	1	8043075	DECAL OVERLAY				
*		8042428	RC TRANSMITTER 8 BUTTON (w/ GRAPHIC OVERLAYS)				
33	1	8043639	BRACKET BOOM ELECTRONIC				
	7	X000320	DEUTSCH DIODE RECEPTACLE				
	1	8040185	RELAY				
	2	8043690	TIME RELAY 2 SEC N/C				
34	1	8044553	WORK LIGHT W/ DUETSCH CONNECTOR BUILT BRACKET				
35	1	8041925	CYLINDER, HYD BOOM 3 1/2 X 8				

BOOM MANIFOLD CAVITY IDENTIFICATION

* NOT SHOWN

112409

VACASSY984

TURRET

BOOM MANUAL ROTATION REV. FLOW

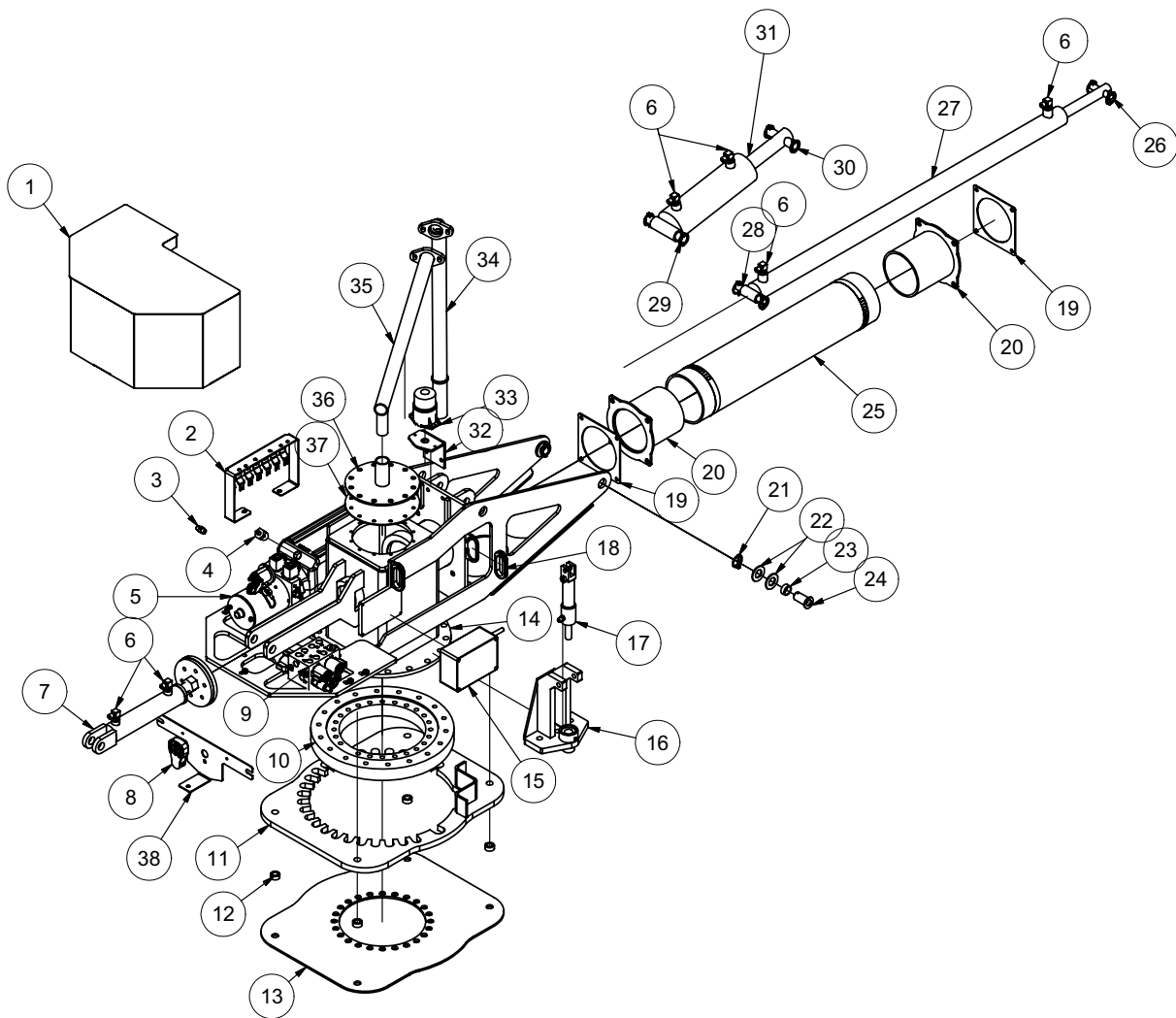

TURRET

BOOM MANUAL ROTATION REV. FLOW

ITEM	QTY	PART #	DESCRIPTION	ITEM	QTY	PART #	DESCRIPTION
1	1	8043090	BOOM GUARD	28	1	8042122	BOOM - EXT. CYL. BASE PIN
2	1	8043639	BRACKET BOOM ELECTRONIC	29	1	8041977	BOOM - PIVOT CYL. BASE PIN
	7	X000320	DEUTSH DIODE RECEPTACLE	30	1	8041990	BOOM - PIVOT CYL. ROD PIN
	1	8040185	RELAY	31	1	8041925	CYLINDER, HYD BOOM 3 1/2" X 8
	2	8043690	TIME RELAY	32	1	8045191	STROBE LIGHT PLATE
3	2	T400037	UNION 6MB-6MJ	33	1	8043139	STROBE LIGHT
4	1	T403018	REDUCER 12MP-4MJ	34	1	8045080	BOOM CABLE TUBE VERTICAL
5	1	8045355	PUMP, HYD. 12V VAC 6QT	35	1	8044504	BOOM CABLE EXT. HORZ.
6	6	T401270	ELBOW, 90 1/2"MB - 3/8"MJ	36	1	8044507	CLEANOUT COVER BOOM WELD'T
7	1	8041327	CYLINDER, HYD. DOOR & REV FLOW	12	12	U000420	SCREW, HC 3/8"-16 X 1"
	2	W201020	WIPER, CYLINDER ROD, 1 1/8" ROD	12	12	U210060	WASHER, LOCK 3/8"
	1	8044480	SEAL PLATE WELDMENT	12	12	U200600	WASHER, FLAT 3/8"
	1	8044482	BOOM SHUTOFF SEAL	37	1	8044475	BOOM TURRET SHUTOFF -
	1	8044483	BOOM SHUTOFF SEAL PLATE SHIELD				CLEANOUT COVER GASKET
	1	U001570	SCREW, HC 1"-8 X 5.00	38	1	8044553	WORK LIGHT W/ DUETSCH
	1	U120060	NUT, LOCK NY 1 - 8				CONNECTOR BUILT BRACKET
8	1	8042426	RC TRANSMITTER (w/ GRAPHIC OVERLAYS)				
*	1	8045653	BOOM REMOTE METAL CLIP				
*	1	X200006	BOOM WIRING HARNESS				
*	1	8041911-1	RUBBER 6-BUTTON PAD	*	1	X300200	CABLE BATTERY GND 1GA 600"
*	1	8043075	DECAL OVERLAY	*	1	X300201	CABLE BATTERY HOT 1GA 600"
*		8042428	RC TRANSMITTER 8 BUTTON	*	1	8042887	ADJUSTABLE CLEVIS - BOOM
9	1	8043580	MANIFOLD ASSY BOOM				
10	1	8042234	SWIVEL BEARING				
*	3	T500020	FITTING, GREASE. 125 STRAIGHT (2 FITTINGS IN INNER RING, 1 IN OUTER RING)	*			NOT SHOWN
11	1	8045195	BOOM MOUNT BRAKE RING				
12	4	8030315	SKID - WATER TANK CLEVIS TUBE				
13	1	8043021	BOOM - LOWER STOP DISC				
14	1	8045139	BOOM TURRET SHUTOFF WELDMENT				
	6	U001281	SCREW, HC .625-11 X 3.50"	PORT	PART#	DESCRIPTION	USED ON
	6	U120020	NYLON LOCK NUT .625-11	1.1	8043584	3-WAY VALVE	ALL
	12	U200140	WASHER, FLAT .625	1.2	8043584	3-WAY VALVE	ALL
15	1	8041915	BOOM - RC RECEIVER 8-RELAY	1.3	8043584	3-WAY VALVE	ALL
		8041916	ANTENNA, BOOM 3" STRAIGHT	1.4	8043584	3-WAY VALVE	ALL
16	1	8045157	BOOM MANUAL BRAKE WELD'T	1.5	8043584	3-WAT VALVE	REVERSE FLOW
	1	T500080	FITTING, GREASE 3/16"	1.6	8043584	3-WAY VALVE	REVERSE FLOW
17	1	8043052	BRAKE CYLINDER	3.2	8043586	CHECK VALVE	MANUAL ROTATION
	1	T400801	PLUG, BREATHER 1/4"NPT	4.2	8042302	PRESSURE SWITCH	MANUAL ROTATION
	1	T402020	UNION 4MJ-4MP			1000 PSI, N/C	
18	2	8042812	GROMMET 2"ID3"OD 1/4"WOG	5	8043587	RELIEF VALVE ADJ	ALL
19	2	8041988	BOOM FLANGE GASKET	7	8043585	2-WAY VALVE N/O	MANUAL ROTATION
20	2	8041958	BOOM - FLEX HOSE ADAPTER WELD'T				
21	10	U340050	PIN LINCH 3/16" X 1 9/16"				
22	4	U200170	WASHER, FLAT 1"				
23	2	8042101	BUSHING BRONZE 1.25" X 1.00" X .50"LG				
24	2	8042124	BOOM - TURRET PIVOT PIN				
25	1	8043678	HOSE AG SUCTION 6-30				
	2	8042104	HOSE CLAMP 6IN T-BOLT				
26	1	8042350	BOOM - EXT. CYLINDER ROD PIN				
27	1	8030359	CYLINDER, HYD 3" X 20" VAC'S				
	1	8043782	HYD. HOSE EXTEND 6-77 ST-90				

BOOM MANIFOLD CAVITY IDENTIFICATION

HOSE STORAGE

BOOM

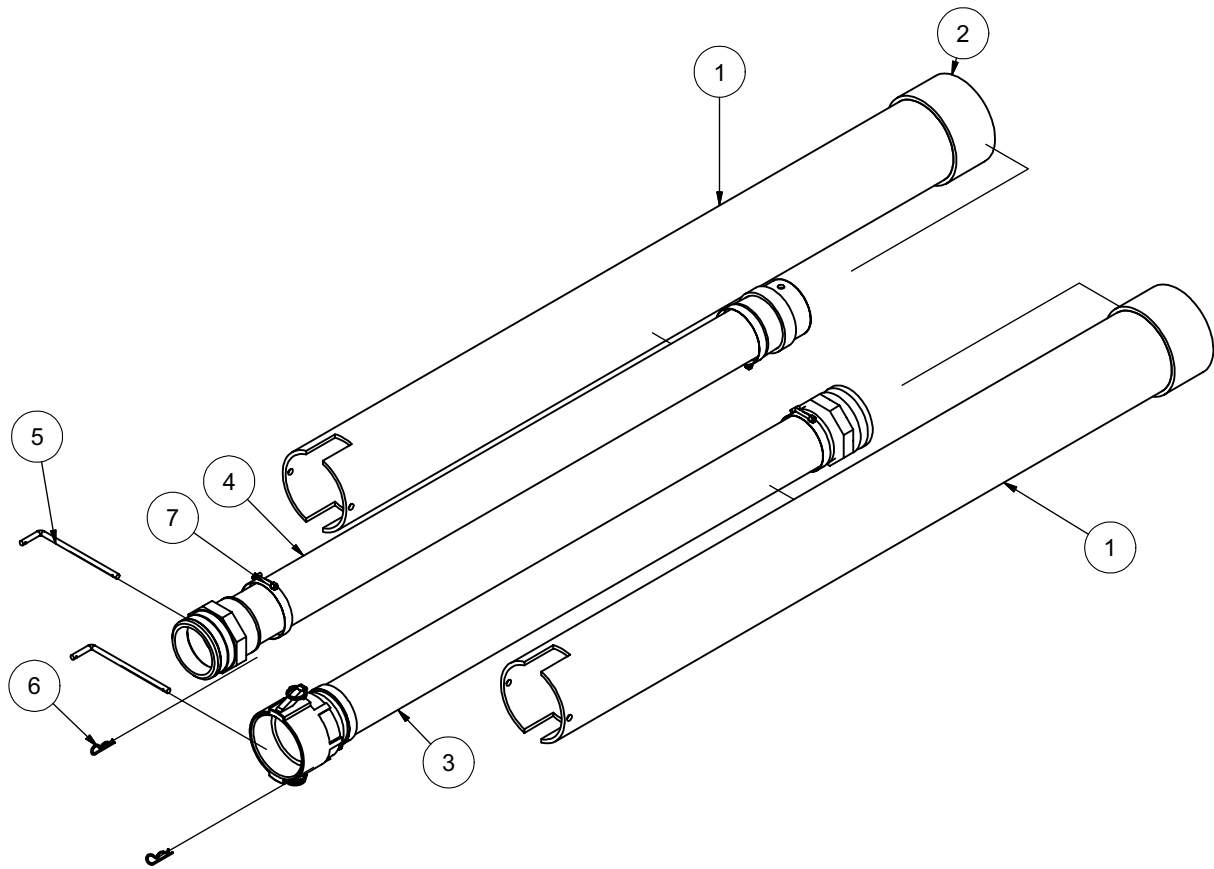

HOSE STORAGE

BOOM

ITEM	QTY	NUMBER	DESCRIPTION
1	2	8042222	BOOM EXTENSION HOSE STORAGE
	2	8043198	CLAMP T-BOLT 700
2	2	8030925	PIPE CAP 6" PVC
3	1	8042137	BOOM HOSE EXTENSION
	1	8041781	BOOM EXTENSION HOSE
	2	8045239	UNION EXHAUST 4"OD - MNPT
	1	8030846	4" FEMALE COUPLER
	1	8030844	4" MAL COUPLER
4	1	8032138	BOOM HOSE EXTENSION WITH 4" UNION PVC
	1	8045723	4" ALUMINUM TUBE 52 1/2"LG
	2	8045728	4" HALF NIPPLE
	1	8030844	COUPLING, 4" ALUM CAMLOCK MXF
	1	8045725	UNION PVC 4"FNPT 4"MSLIP w/HOLE
5	2	8041101	HOSE STORAGE RETAINING ROD
	2	8041485	LANYARD CABLE
6	2	R700160	R-CLIP
7	4	8042606	CLAMP T-BOLT 450

Hot Box Assembly

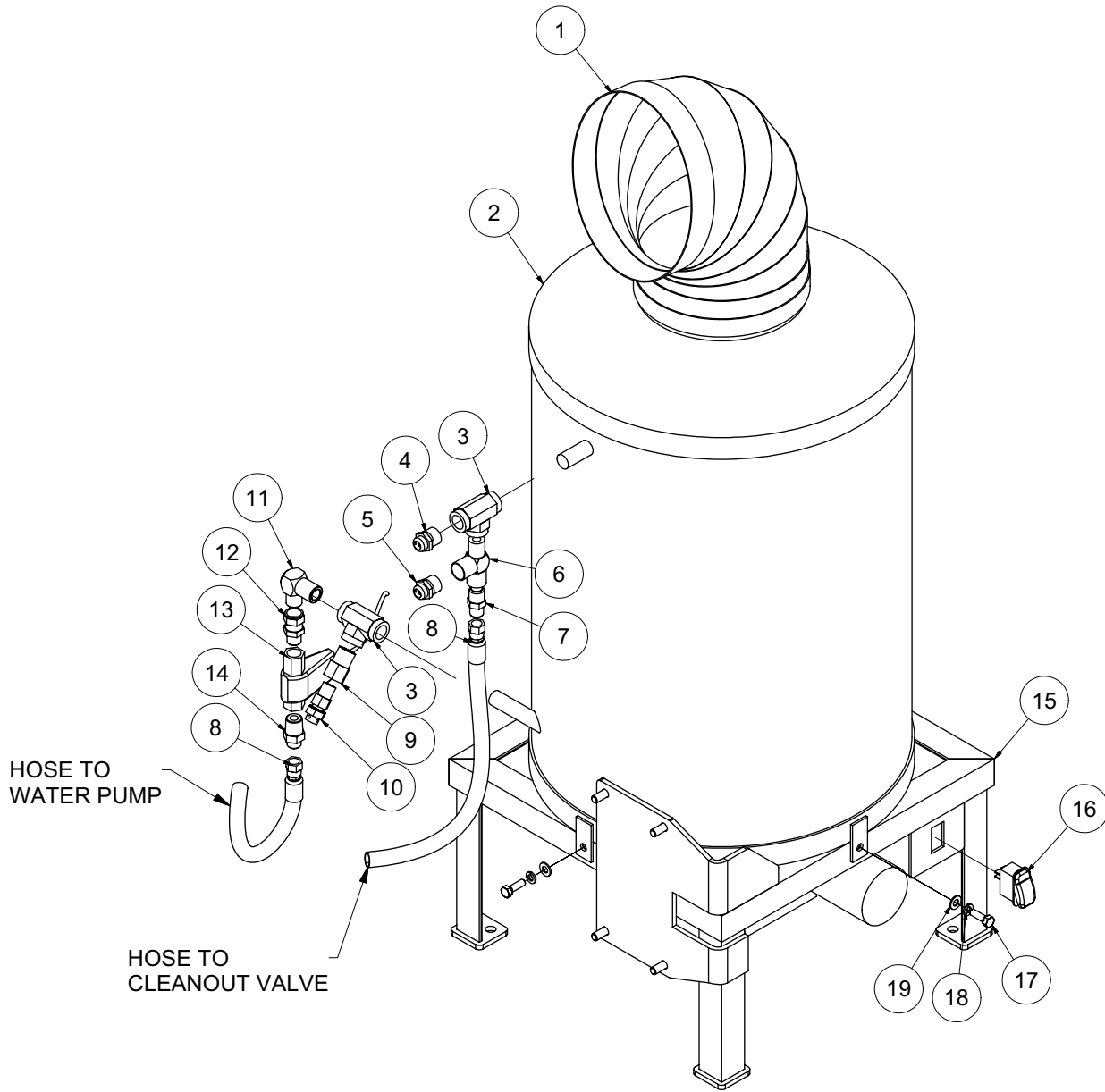

Hot Box Assembly

ITEM	QTY	NUMBER	DESCRIPTION
1	1	8046535	8" ELBOW EXHAUST (AQUA-BLAST)
2	1	8046448	HOT BOX, VERTICAL
3	2	T402130	TEE, 1/2"FP - 1/2FP - 1/2FP
4	1	8046536	120 TEMP. SWITCH NORM CLOSRD
5	1	8046537	165 TEMP. SWITCH NORM CLOSED
6	1	T402156	TEE, 1/2MP - 1/2FP - 1/2FP
7	1	T400029	REDUCER, 1/2"MP - 3/8"MJ
8	2	T320040	FITTING, HOSE 6HO - 6FJ
9	1	T400024	REDUCER, 1/2MP - 3/8FP
10	1	8046448-1	TEMPERTURE RELIEF
11	1	T401140	ELBOW 8MP - 8MJ
12	1	T401125	REDUCER 3/8MP - 1/2FJ
13	1	8031267	FLOW SWITCH
14	1	T400028	UNION 3/8MP - 3/8MJ
15	1	8046515	HOT BOX WELDMENT
16	1	X000271	SWITCH HIGH / LOW
17	3	U200020	SCREW, HC 5/16-18 X 1.00
18	3	U210040	WASHER, LOCK 5/16
19	3	U200040	WASHER, FLAT 5/16

* ITEM NOT SHOWN

Arrow Board Option

ARROW BOARD & DUST COVER
NOT DRAWN TO SCALE

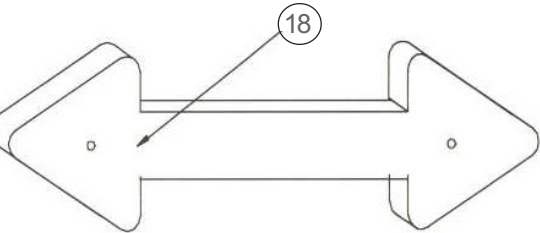

NOTE: MOUNTING BRACKETS MUST BE ATTACHED TO ARROW BOARD BEFORE DUST COVER IS REPLACED

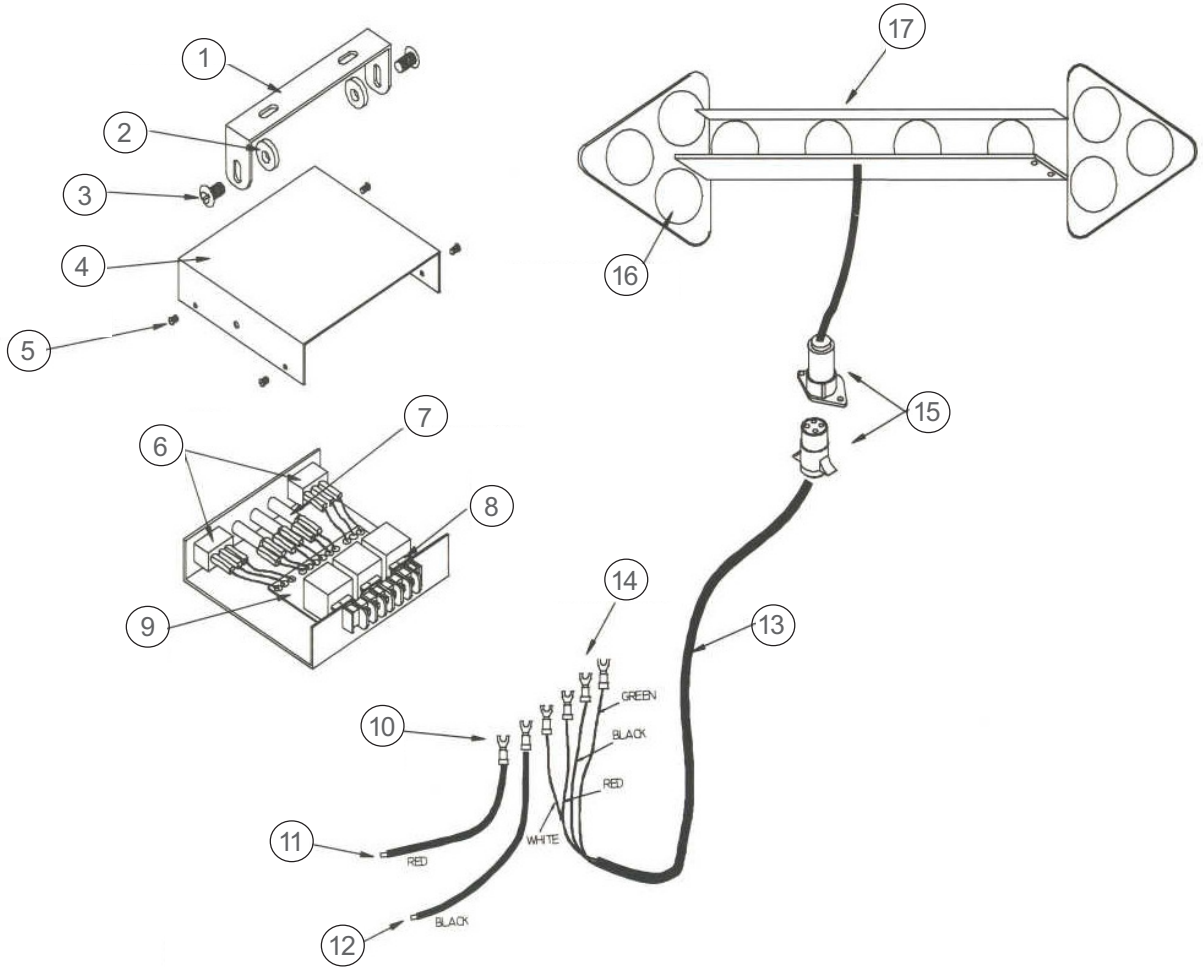

Arrow Board Option

ITEM	QTY	NUMBER	DESCRIPTION
1	1	8042197-1	MOUNTING BAIL
2	2	8042197-2	WASHER
3	2	8042197-3	BOLT
4	1	8042197-4	COVER
5	4	8042197-5	MACHINE SCREW
6	2	8042197-6	SPDT SWITCH
7	3	8042197-7	RED PILOT LAMP
8	1	8042197-8	15 AMP FUSE
9	1	8042197-9	CIRCUIT BOARD ASSY
10	2	8042197-10	#6 BLUE SPADE CONNECTOR
11	4'	8042197-11	RED
12	4'	8042197-12	BLACK
13	20'	8042197-13	CABLE HARNESS
14	4	8042197-14	#6 BLUE SPADE CONNECTOR
15	1	8042197-15	4-WAY CONNECTOR
16	1	8042197-16	STANDARD LAMP ASSY
17	1	8042197-17	ARROW BOARD FRAME
18	1	8042197-18	DUST COVER

Vacuum Diesel Engine Schematic

VACUUM DIESEL ENGINE SCHEMATIC

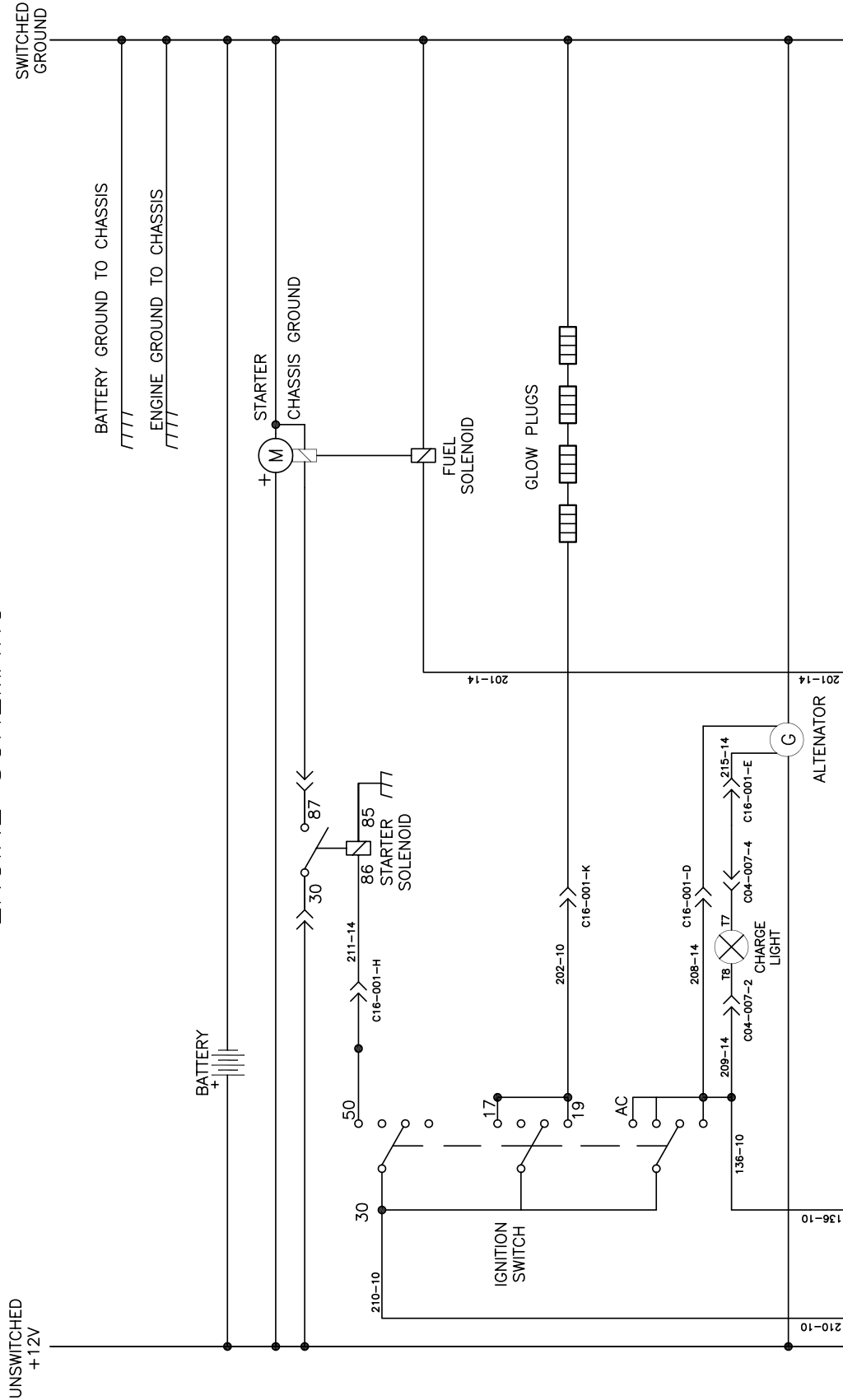

Vacuum Diesel Engine Schematic

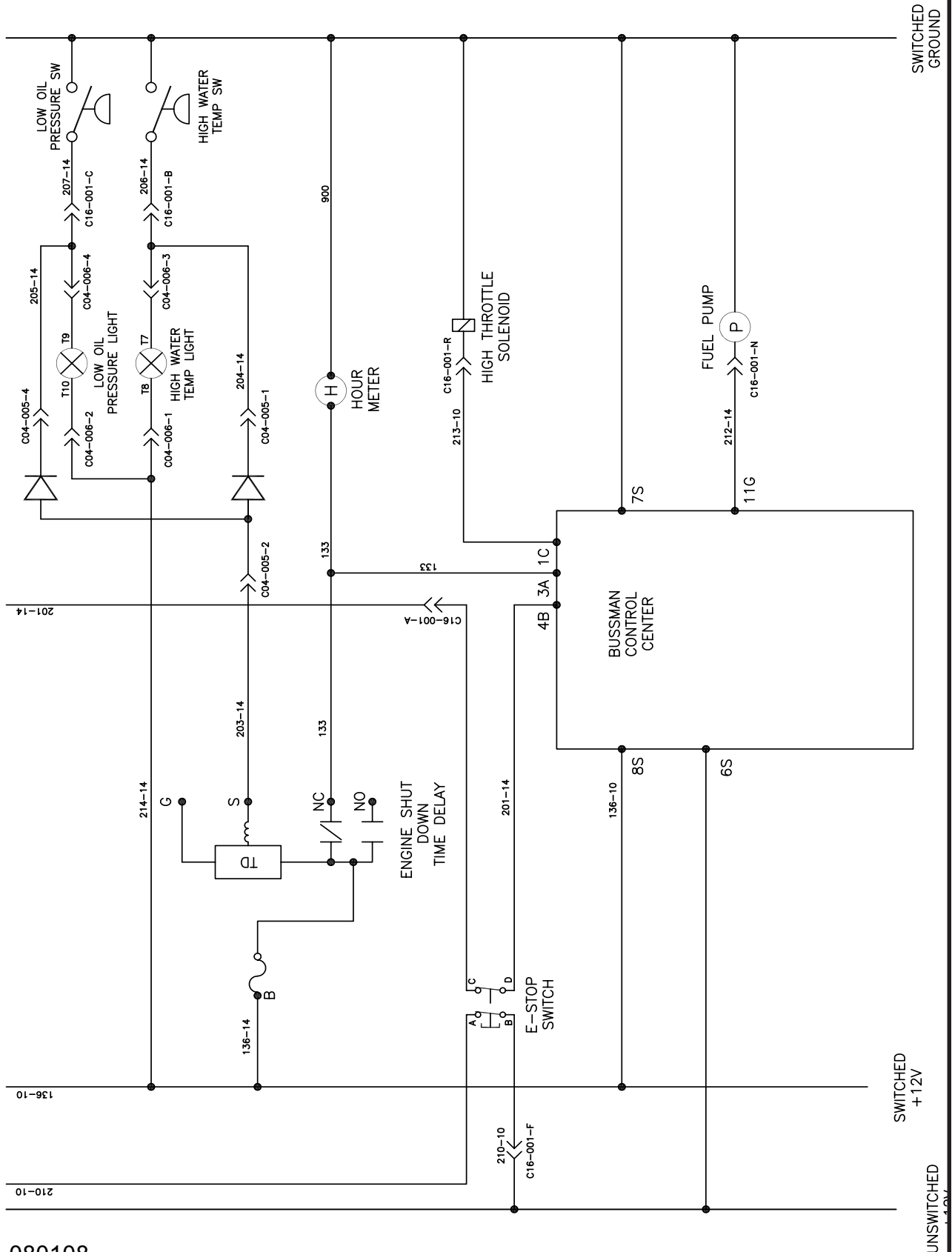

080108

Vacuum Diesel Engine Schematic

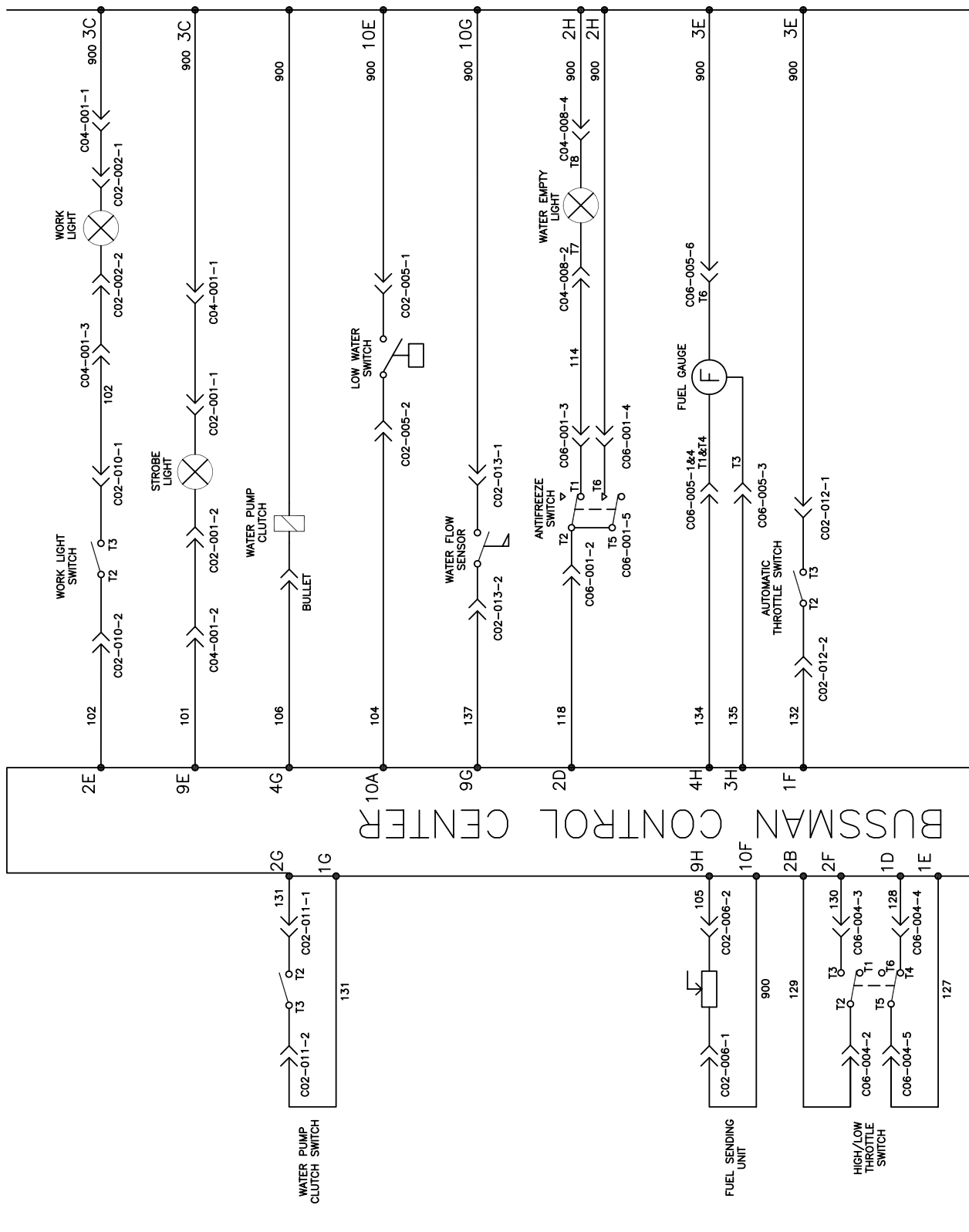

Vacuum Diesel Engine Schematic

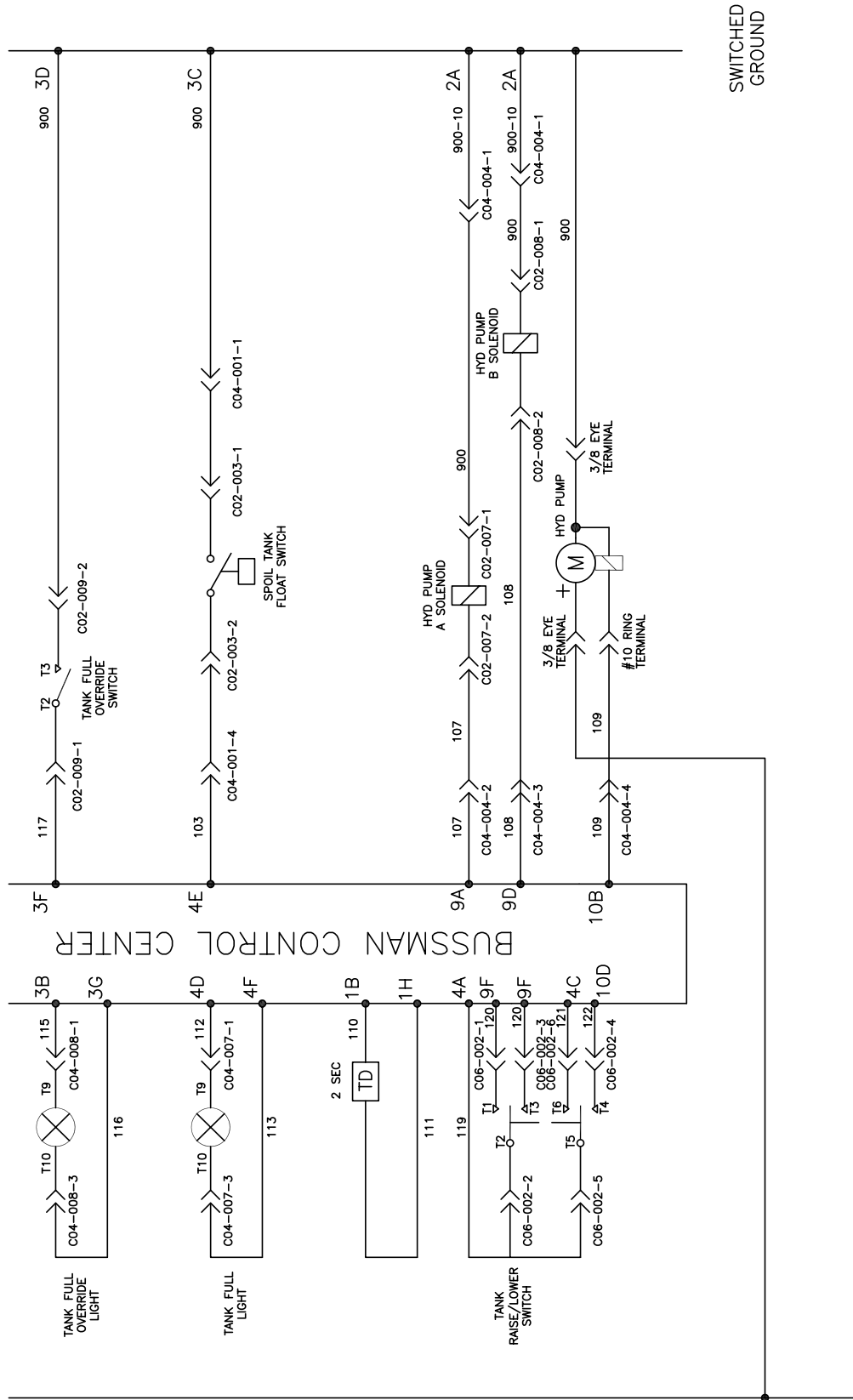

Vacuum Diesel Engine Schematic

BUSSMAN CONTROL CENTER OPTIONS

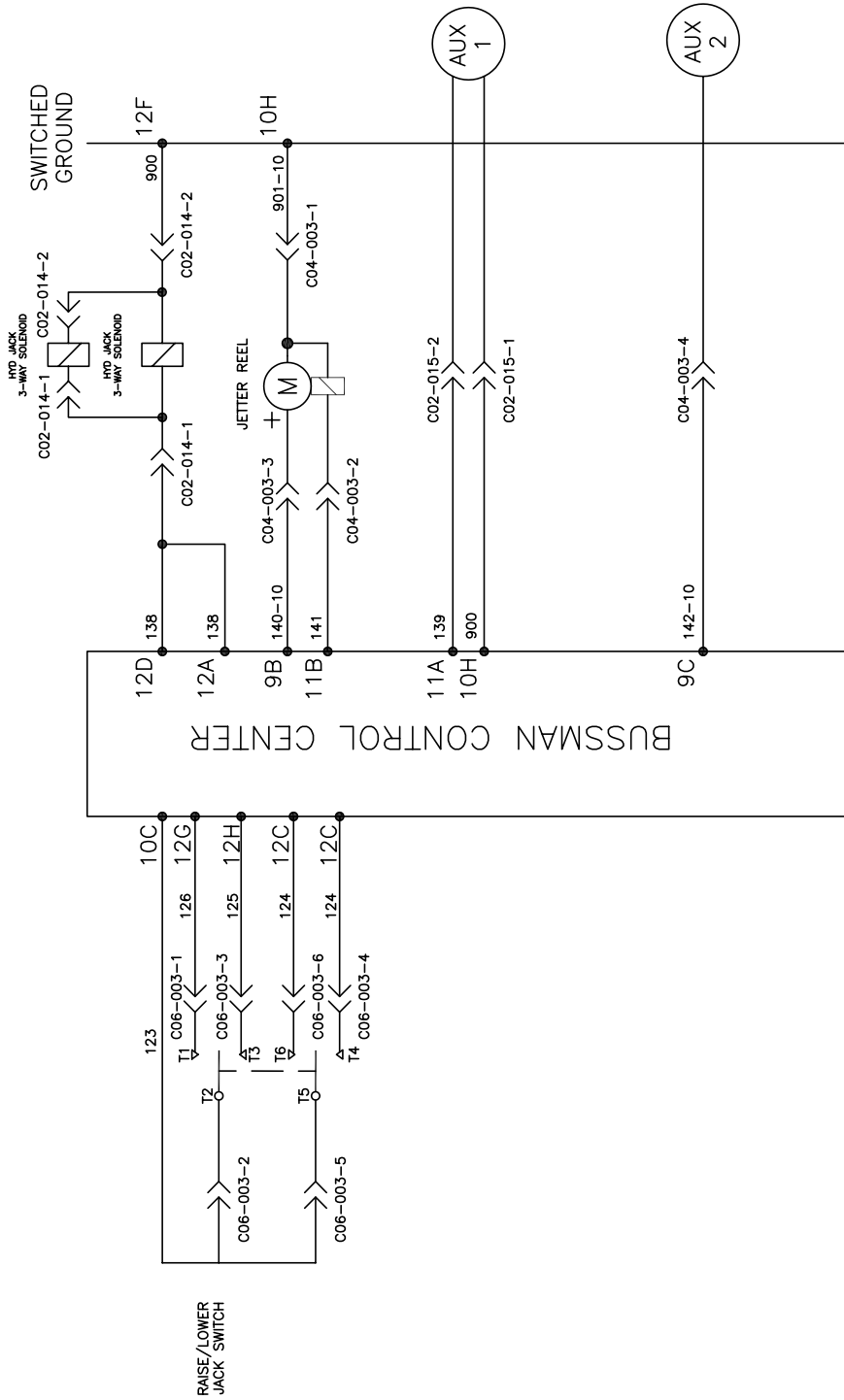

PAGE LEFT BLANK

Boom Wiring Schematic

DOUBLE ACTING GATE VALVE CYLINDER

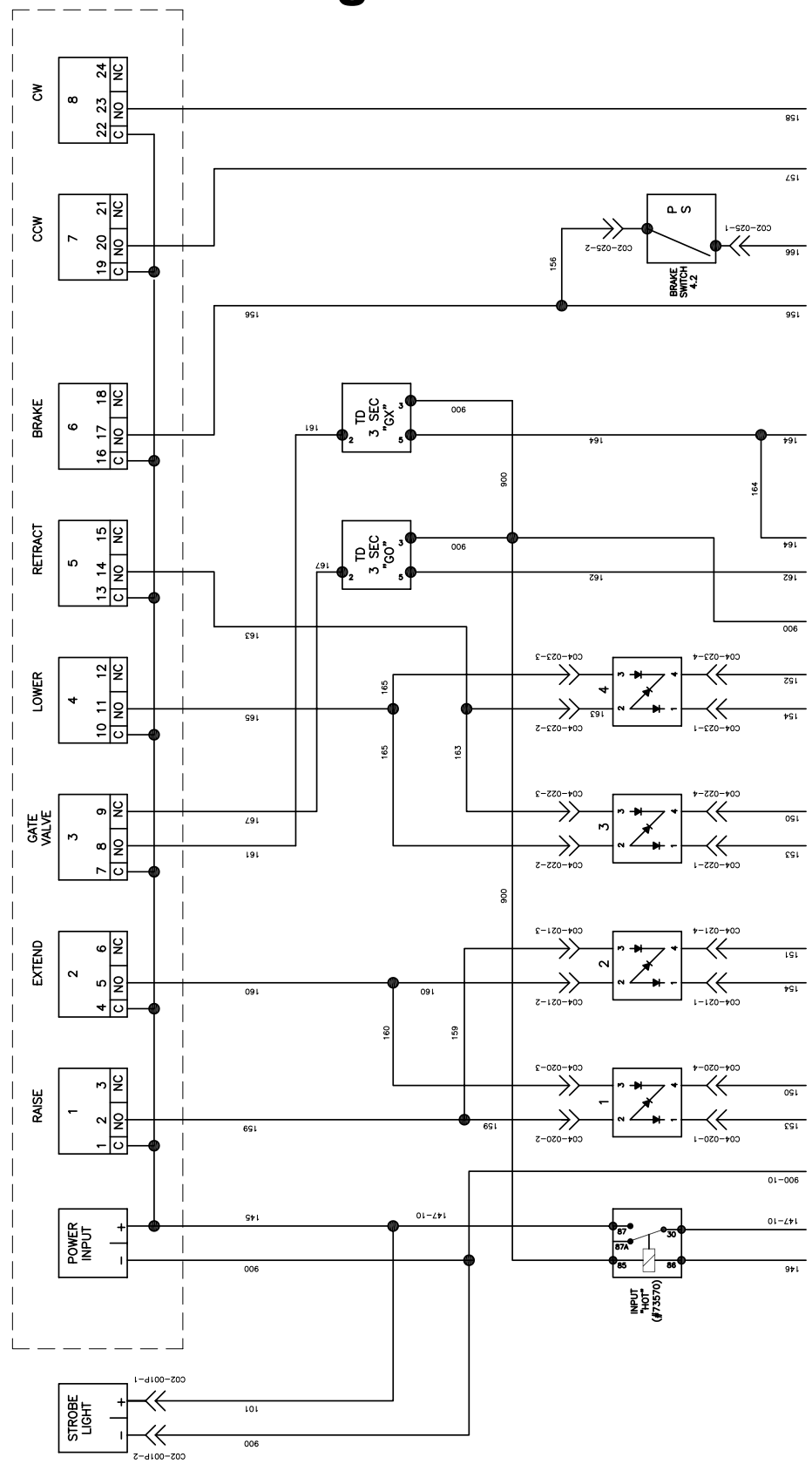

Boom Wiring Schematic

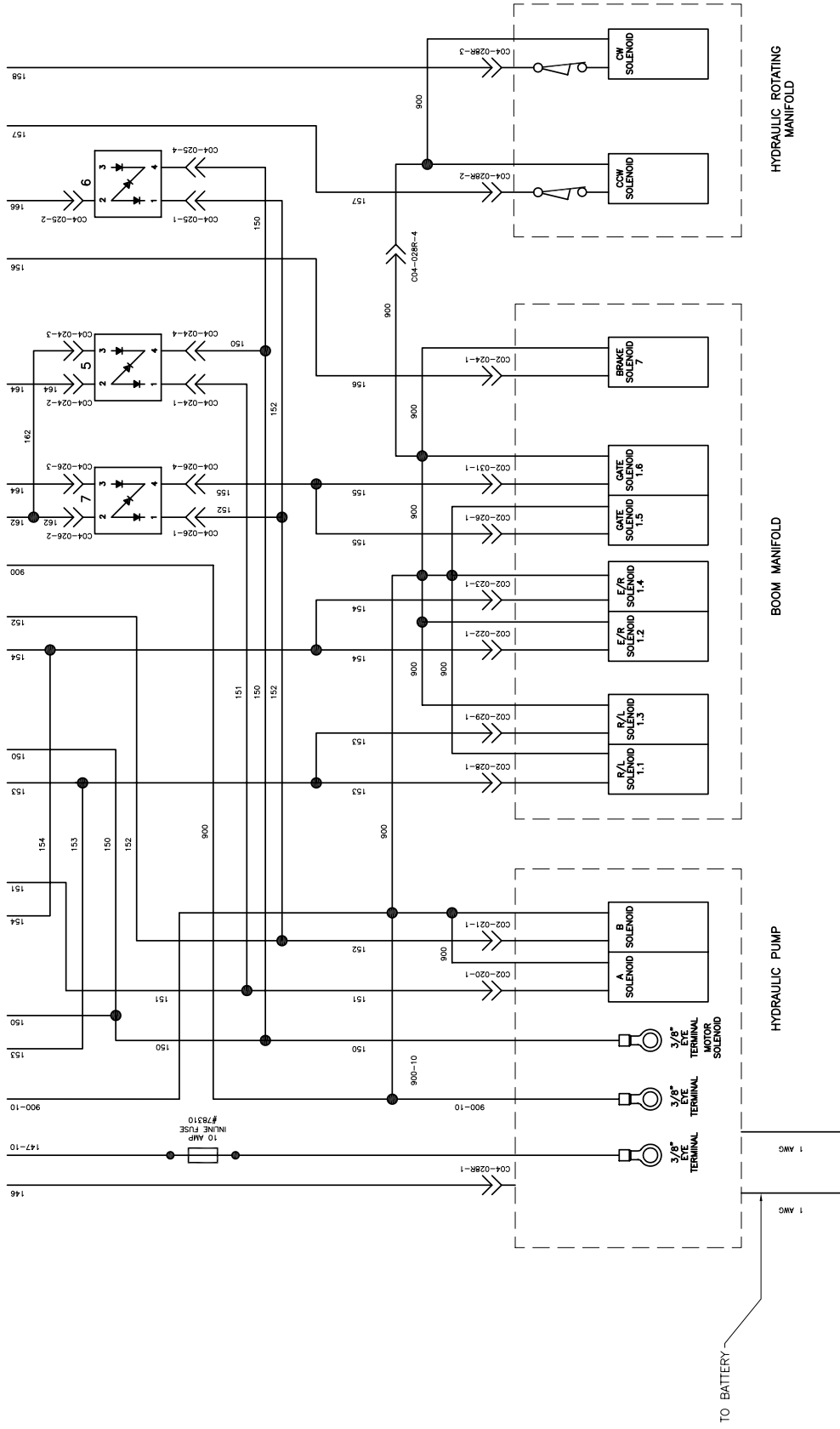

080108

PAGE LEFT BLANK

Arrow Board Option

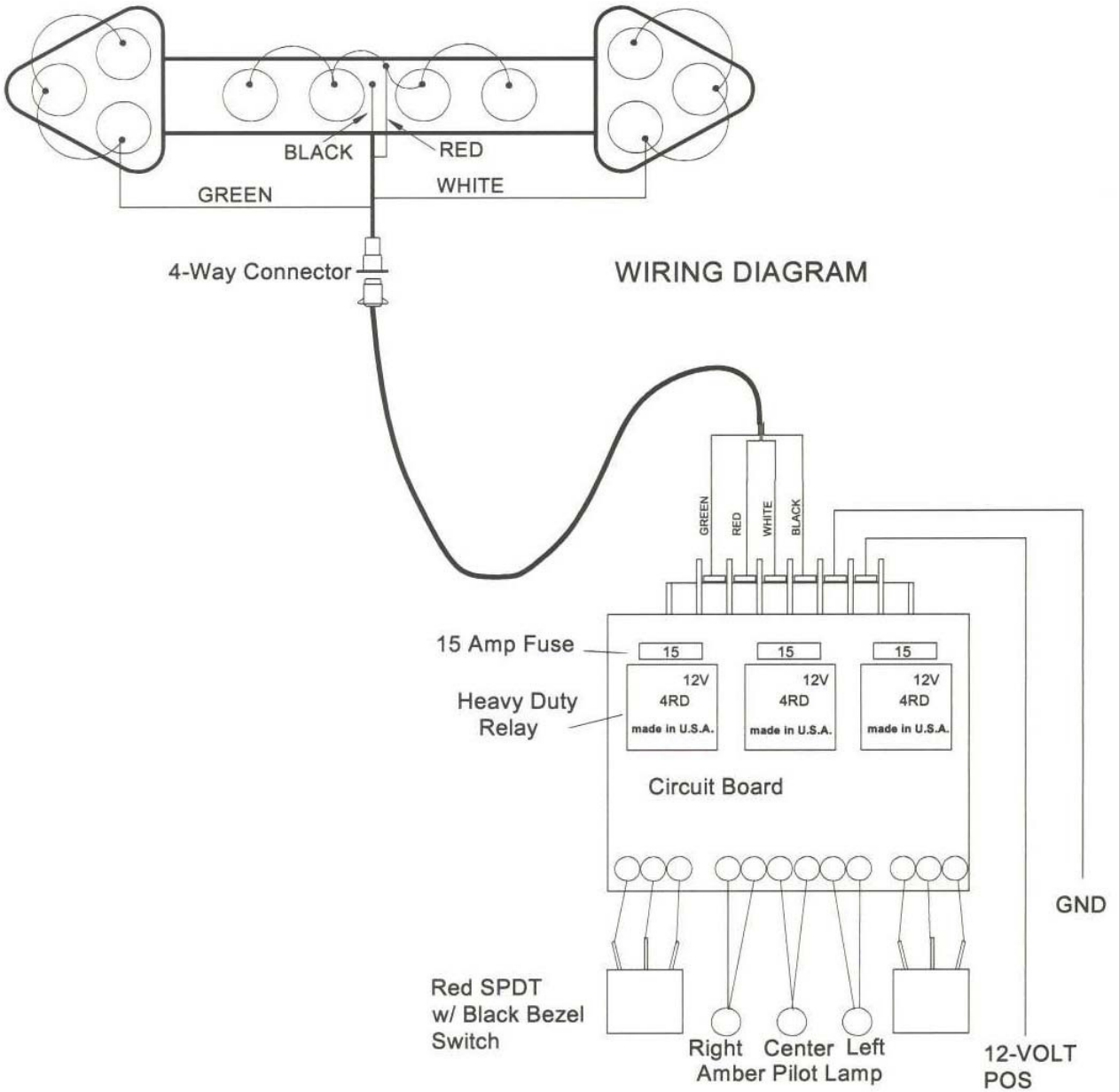

PAGE LEFT BLANK

TANK AND OPTIONAL JACK HYDRAULIC SCHEMATIC (2-Stage)

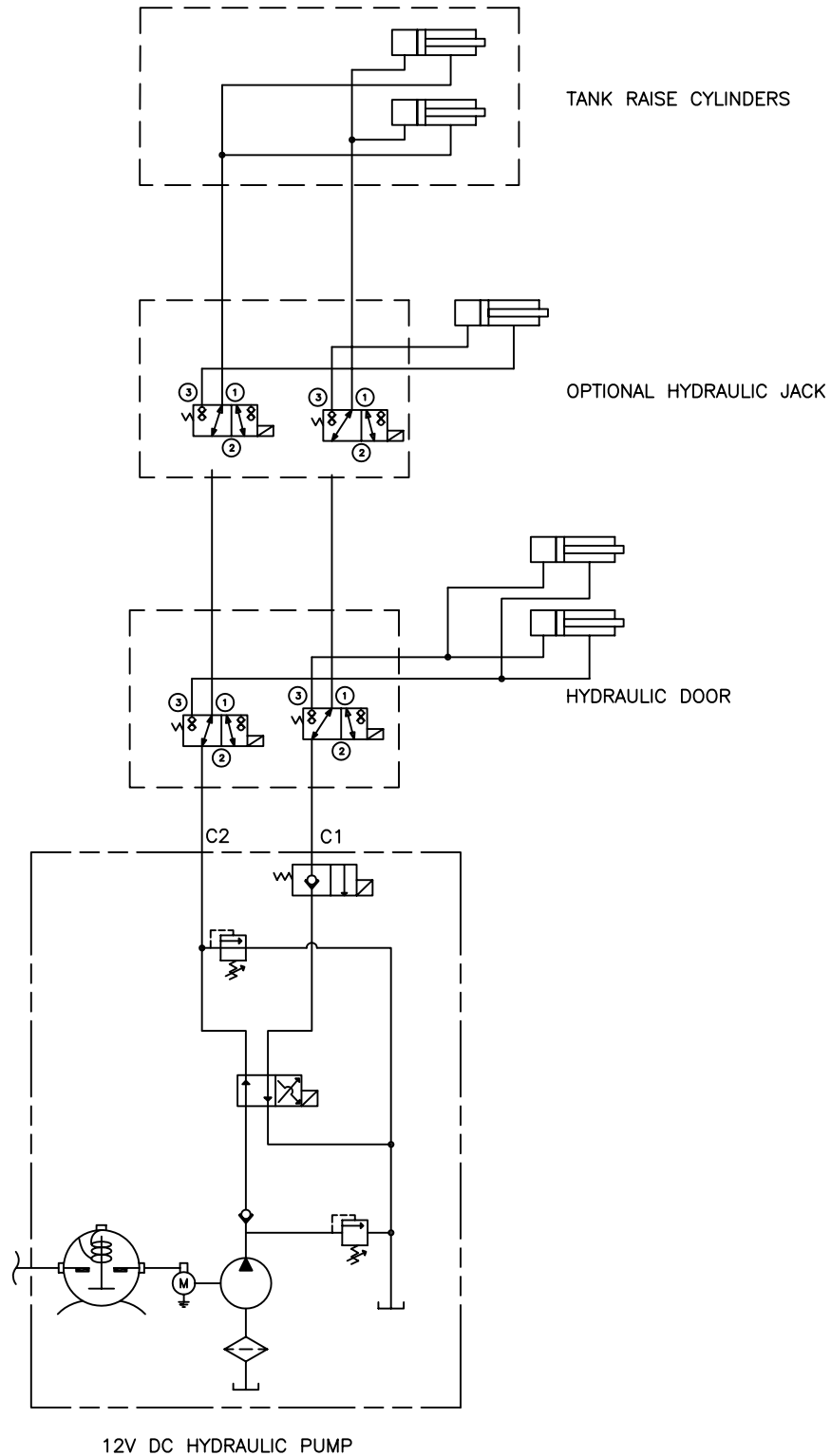

051410-E

PAGE LEFT BLANK

Boom Hydraulic Schematic

BOOM HYDRAULIC SCHEMATIC

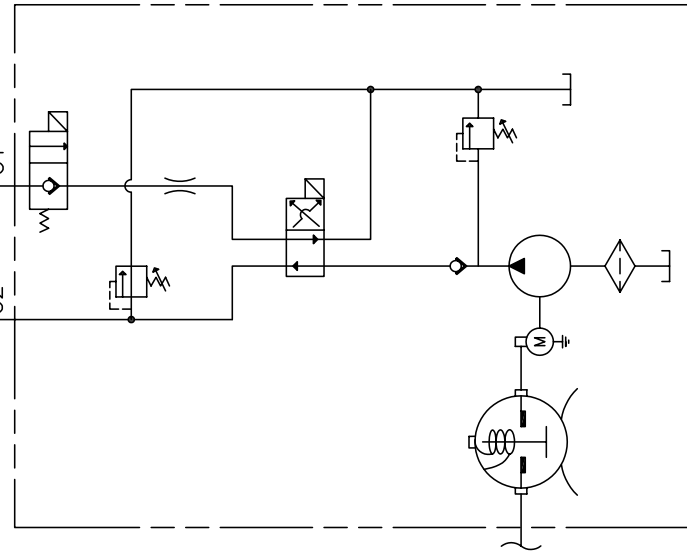
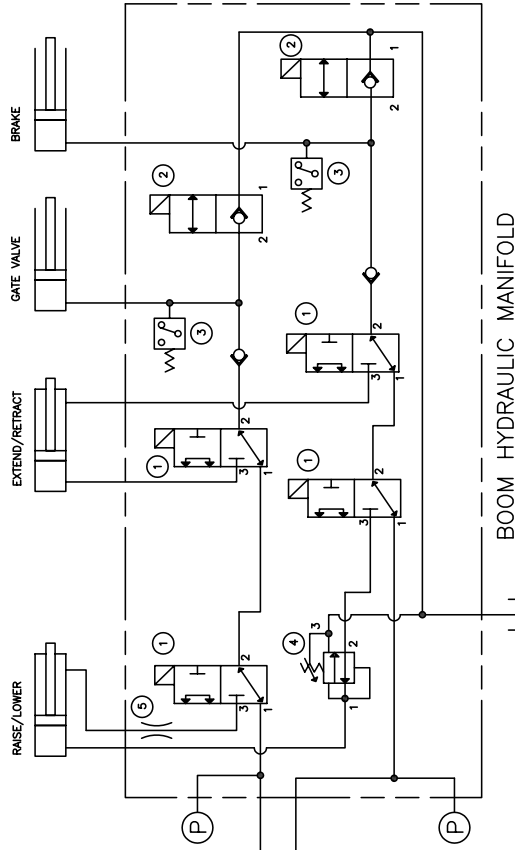

MCL#	MFG	TYPE	MODEL
1	VICKERS	3 WAY VALVE	SV1-10
2	VICKERS	2 WAY VALVE	SV3-10-C-6T12DG
*3	NASON	PRESSURE SWITCH	XM-4B-2000R/HR
4	VICKERS	RETRACT VALVE	PRV2-10
5		ORIFICE .031	

*PRESSURE SETTING 1000psi

12V DC HYDRAULIC PUMP

PAGE LEFT BLANK

ROOTS

Blowers Compressors Exhausters

Universal URAI-DSL

Contents

Information Summary	Troubleshooting
Safety Precautions	Inspection & Maintenance
Operating Limitations	Data
Lubrication	Assembly Drawings
Operation	Parts List

Do These Things To Get The Most From Your ROOTS™ blower

- **Make sure both driving and driven equipment is correctly lubricated before start-up. See LUBRICATION.**
- In event of trouble during installation or operation, do not attempt repairs of ROOTS furnished equipment. Notify ROOTS, giving all nameplate information plus an outline of operating conditions and a description of the trouble. Unauthorized attempts at equipment repair may void ROOTS warranty.
- Units out of warranty may be repaired or adjusted by the owner. Good inspection and maintenance practices should reduce the needs for repairs.

NOTE: Information in this manual is correct as of the date of publication. ROOTS reserves the right to make design or material changes without notice, and without obligation to make similar changes without notice, and without obligation to make similar changes on equipment of prior manufacture.

Safety Precautions

It is important that all personnel observe safety precautions to minimize the chances of injury. Among many considerations, the following should be particularly noted:

- Blower casing and associated piping or accessories may become hot enough to cause major skin burns on contact.
- Internal and external rotating parts of the blower and driving equipment can produce serious physical injuries. Do not reach into any opening in the blower while it is operating, or while subject to accidental starting. Protect external moving parts with adequate guards.
- Disconnect power before doing any work, and avoid bypassing or rendering inoperative any safety or protective devices.
- If blower is operated with piping disconnected, place a strong coarse screen over the inlet and avoid standing in the discharge air stream. **CAUTION: Never cover the blower inlet with your hand or other part of body.**
- Stay clear of the blast from pressure relief valves and the suction area of vacuum relief valves.
- Use proper care and good procedures in handling, lifting, installing, operating and maintaining the equipment.
- Casing pressure must not exceed 25 PSI (1725 mbar) gauge. Do not pressurize vented cavities from an external source, nor restrict the vents without first consulting Roots.
- Do not use air blowers on explosive or hazardous gases.
- Other potential hazards to safety may also be associated with operation of this equipment. All personnel working in or passing through the area should be trained to exercise adequate general safety precautions.

Operating Limitations

A ROOTS blower or exhauster must be operated within certain approved limiting conditions to enable continued satisfactory performance. Warranty is contingent on such operation.

Maximum limits for pressure, temperature and speed are specified in TABLE 1 for various models & sizes of blowers & exhausters. These limits apply to all units of normal construction, when operated under standard atmospheric conditions. Be sure to arrange connections or taps for instruments, thermometers and pressure or vacuum gauges at or near the inlet and discharge connections of the unit. These, along with a tachometer, will enable periodic checks of operating conditions.

PRESSURE – The pressure rise, between inlet and discharge, must not exceed the figure listed for the specific unit frame size concerned. Also, in any system where the unit inlet is at a positive pressure above atmosphere a maximum case rating of 25 PSI gauge (1725 mbar) should not be exceeded without first consulting Roots. Never should the maximum allowable differential pressure be exceeded.

On vacuum service, with the discharge to atmospheric pressure, the inlet suction or vacuum must not be greater than values listed for the specific frame size.

TEMPERATURE – Blower & exhauster frame sizes are approved only for installations where the following temperature limitations can be maintained in service:

- Measured temperature rise must not exceed listed values when the inlet is at ambient temperature. Ambient is considered as the general temperature of the space around the unit. This is not outdoor temperature unless the unit is installed outdoors.
- If inlet temperature is higher than ambient, the listed allowable temperature rise values must be reduced by 2/3 of the difference between the actual measured inlet temperature and the ambient temperature.
- The average of the inlet and discharge temperature must not exceed 250°F. (121°C).
- The ambient temperature of the space the blower/motor is installed in should not be higher than 120°F (48.8°C).

SPEED – These blowers & exhausters may be operated at speeds up to the maximum listed for the various frame sizes. They may be direct coupled to suitable constant speed drivers if pressure/temperature conditions are also within limits. At low speeds, excessive temperature rise may be a limiting factor.

Special Note: The listed maximum allowable temperature rise for any particular blower & exhauster may occur well before its maximum pressure or vacuum rating is reached. This may occur at high altitude, low vacuum or at very low speed. The units' operating limit is always determined by the maximum rating reached first. It can be any one of the three: Pressure, Temperature or Speed.

Lubrication

For Units with Splash Lubrication on Both Ends

Bearings and oil seals are lubricated by the action of the timing gears or oil slingers which dip into the main oil sumps

causing oil to splash directly on gears and into bearings and seals. A drain port is provided below each bearing to prevent an excessive amount of oil in the bearings. Seals located inboard of the bearings in each headplate effectively retain oil within the sumps. Any small leakage that may occur should the seals wear passes into a cavity in each vented headplate and is drained downward.

Oil sumps on each end of the blower are filled by removing top vent plugs, Item (25), and filling until oil reaches the middle of the oil level sight gauge when the unit is not operating, Item (45 or 53), DO NOT FILL PAST THE MIDDLE OF THE SIGHT GLASS.

Initial filling of the sumps should be accomplished with the blower not operating, in order to obtain the correct oil level. Approximate oil quantities required for blowers of the various models and configurations are listed in Table 3. Use a good grade of industrial type non-detergent, rust inhibiting, anti-foaming oil and of correct viscosity per Table 2. ***ROOTS synthetic oil (Roots P/N 813-106-) is specified and recommended.** Roots does not recommend automotive type lubricants, as they are not formulated with the properties mentioned above.

The oil level may rise or fall on the gauge during operation, to an extent depending somewhat on oil temperature and blower speed.

Proper lubrication is usually the most important single consideration in obtaining maximum service life and satisfactory operation from the unit. Unless operating conditions are quite severe, a weekly check of oil level and necessary addition of lubricant should be sufficient. During the first week of operation, check the oil levels in the oil sumps about once a day, and watch for leaks. Replenish as necessary. Thereafter, an occasional check should be sufficient. It is recommended that the oil be changed after initial 100 hours of operation. Frequent oil changing is not necessary unless the blower is operated in a very dusty location.

Normal life expectancy of petroleum based oils is about 2000 hours with an oil temperature of about 180°F (82°C). As the oil temperature increases by increments of 15-18°F (8°C - 10°C), the life is reduced by half. Example: Oil temperatures of 210-216°F (99°C - 102°C) will produce life expectancy of 1/4 or 500 hours. Therefore, it is considered normal to have oil change periods of 500 hours with petroleum based oils.

Normal life expectancy of ROOTS™ Synthetic Oil is about 4000 to 8000 hours with an oil temperature of about 180°F (82°C). As the oil temperature increases by increments of 15-18°F (8°C - 10°C), the life is reduced by half. Example: Oil temperatures of 210-216°F (99°C - 102°C) will produce life expectancy of 1/4 or 1000 to 2000 hours.

NOTE: To estimate oil temperature, multiply the discharge temperature of the blower by 0.80. Example: if the discharge air temperature of the blower is 200° F, it is estimated that the oil temperature is 160° F.

*ROOTS™ Synthetic Oil & Grease is superior in performance to petroleum based products. It has high oxidation stability, excellent corrosion protection, extremely high film strength and low coefficient of friction. Typical oil change intervals are increased 2-3 times over petroleum based lubricants. Also, ROOTS™ Synthetic Oil is 100% compatible with petroleum based oils. Simply drain the oil in the blower and refill the reservoirs with ROOTS™ Synthetic Oil to maintain optimum performance of your ROOTS™ blower.

Operation

Before operating a blower under power for the first time, recheck the unit and the installation thoroughly to reduce the likelihood of avoidable troubles. Use the following procedure check list as a guide, but consider any other special conditions in the installation.

- Be certain that no bolts, tools, rags, or debris have been left in the blower air chamber or piping.
- If an outdoor intake without filter is used, be sure the opening is located so it cannot pick up dirt and is protected by a strong screen or grille. Use of the temporary protective screen as described under INSTALLATION is strongly recommended.
- Recheck blower leveling, drive alignment and tightness of all mounting bolts if installation is not recent. If belt drive is used, adjust belt tension correctly.
- Turn drive shaft by hand to make sure impellers still rotate without bumping or rubbing at any point.
- Ensure oil levels in the main oil sumps are correct.
- Check lubrication of driver. If it is an electric motor, be sure that power is available and that electrical overload devices are installed and workable.
- Open the manual unloading valve in the discharge air line. If a valve is in the inlet piping, be sure it is open.
- Bump blower a few revolutions with driver to check that direction of rotation agrees with arrow near blower shaft, and that both coast freely to a stop.

After the preceding points are cleared, blower is ready for trial operation under "no-load" conditions. The following procedure is suggested to cover this initial operation test period.

- a. Start blower, let it accelerate to full speed, then shut off. Listen for knocking sounds, both with power on and as speed slows down.
- b. After blower comes to a complete stop, repeat above, but let blower run 2 or 3 minutes. Check for noises, such as knocking sounds.
- c. After blower comes to a complete stop, operate blower for about 10 minutes unloaded. Check oil levels. Observe cylinder and headplate surfaces for development of hot spots such as burned paint, indicating impeller rubs. Be aware of any noticeable increase in vibration.

Assuming that all trials have been satisfactory, or that necessary corrections have been made, the blower should now have a final check run of at least one hour under normal operating conditions. After blower is restarted, gradually

close the discharge unloading valve to apply working pressure. At this point it is recommended that a pressure gauge or manometer be connected into the discharge line if not already provided, and that thermometers be in both inlet and discharge lines. Readings from these instruments will show whether pressure or temperature ratings of the blower are being exceeded.

During the final run, check operating conditions frequently and observe the oil levels at reasonable intervals. If excessive noise or local heating develops, shut down immediately and determine the cause. If either pressure rise or temperature rise across the blower exceeds the limit specified in this manual, shut down and investigate conditions in the piping system. Refer to the TROUBLESHOOTING CHECKLIST for suggestions on various problems that may appear.

The blower should now be ready for continuous duty operation at full load. During the first few days make periodic checks to determine whether all conditions remain steady, or at least acceptable. This may be particularly important if the blower is supplying air to a process system where conditions can vary. At the first opportunity, stop the blower and clean the temporary inlet protective screen. If no appreciable amount of debris has collected, the screen may be removed. See comments under INSTALLATION. At this same time, verify leveling, coupling alignment or belt tension, and mounting bolt tightness.

Should operating experience prove that blower capacity is a little too high for the actual air requirements, a small excess may be blown off continuously through the manual unloading or vent valve. Never rely on the pressure relief valve as an automatic vent. Such use may cause the discharge pressure to become excessive, and can also result in failure of the valve itself. If blower capacity appears to be too low, refer to the TROUBLESHOOTING CHECKLIST.

Vibration Assessment Criteria

With measurements taken at the bearing locations on the housings, see chart below for an appropriate assessment guide for rotary lobe blowers rigidly mounted on stiff foundations.

In general, blower vibration levels should be monitored on a regular basis and the vibration trend observed for progressive or sudden change in level. If such a change occurs, the cause should be determined through spectral analysis.

As shown on the chart below, the level of all pass vibration will determine the need to measure discrete frequency vibration levels and the action required.

All Pass Vibration (in/sec)	Discrete Frequency Vibration (in/sec)	Action
0.45 or less	N/R	Acceptable
Greater than 0.45 but 1.0 or less	0.45 or less @ any frequency	Acceptable
	Greater than 0.45 @ any frequency	Investigate
Greater than 1.0	Less than 1.0	Investigate
	Greater than 1.0	Investigate

Troubleshooting Checklist

Trouble	Item	Possible Cause	Remedy
No flow	1	Speed too low	Check by tachometer and compare with published performance
	2	Wrong rotation	Compare actual rotation with Figure 1 Change driver if wrong
	3	Obstruction in piping	Check piping, valves, silencer to assure open flow path
Low capacity	4	Speed too low	See item 1, If belt drive, check for slippage and readjust tension
	5	Excessive pressure rise	Check inlet vacuum and discharge pressure and compare with Published performance
	6	Obstruction in piping	See item 3
	7	Excessive slip	Check inside of casing for worn or eroded surfaces causing excessive clearances
Excessive power	8	Speed too high	Check speed and compare with published performance
	9	Excessive pressure rise	See Item 5
	10	Impeller rubbing	Inspect outside of cylinder for high temperature areas, then check for impeller contact at these points. Correct blower mounting, drive alignment
	11	Scale, sludge, rust or product build up	Clean blower appropriately
Damage to bearings or gears	12	Inadequate lubrication	Check oil sump levels in gear and drive end headplates
	13	Excessive lubrication	Check oil levels. If correct, drain and refill with clean oil of recommended grade
	14	Excessive pressure rise	See Item 5
	15	Coupling misalignment	Check carefully. Realign if questionable
	16	Excessive belt tension	Readjust for correct tension
Vibration	17	Misalignment	See Item 15
	18	Impellers rubbing	See Item 10
	19	Worn bearings/gears	Check gear backlash and condition of bearings, and replace as indicated
	20	Unbalanced or rubbing impeller	Scale or process material may build up on casing and impellers, or inside impellers. Remove build-up to restore original clearances and impeller balance
	21	Driver or blower loose	Tighten mounting bolts securely
	22	Piping resonances	Determine whether standing wave pressure pulsations are present in the piping
	23	Scale/sludge build-ups	Clean out interior of impeller lobes to restore dynamic balance
Driver stops, or will not start	24	Casing strain	Re-work piping alignment to remove excess strain
	25	Impeller stuck	Check for excessive hot spot on headplate or cylinder. See item 10. Look for defective shaft bearing and/or gear teeth
	26	Scale, sludge, rust or product build-up	Clean blower appropriately
Excessive breather	27	Broken seal	Replace seals
Blow-by or excessive oil leakage to vent area	28	Defective O-ring	Replace seals and O-ring
Excessive oil leakage in vent area	29	Defective/plugged breather	Replace breather and monitor oil leakage
	30	Oil level too high	Check sump levels in gear and drive headplates.
	31	Oil type or viscosity incorrect	Check oil to insure it meets recommendations. Drain then fill with clean oil of recommended grade.
	32	Blower running hot	Check blower operating conditions to ensure they are within the operating limitations defined in this manual.

Inspection & Maintenance: Universal RAI® series blowers

A good program of consistent inspection and maintenance is the most reliable method of minimizing repairs to a blower. A simple record of services and dates will help keep this work on a regular schedule. Basic service needs are:

- Lubrication
- Checking for hot spots
- Checking for increases or changes in vibration and noise
- Recording of operating pressures and temperatures

Above all, a blower must be operated within its specified rating limits, to obtain satisfactory service life.

A newly installed blower should be checked often during the first month of full-time operation. Attention there after may be less frequent assuming satisfactory performance. Lubrication is normally the most important consideration and weekly checks of lubricant levels in the gearbox and bearing reservoirs should be customary. Complete oil change schedules are discussed under **LUBRICATION**.

Driver lubrication practices should be in accordance with the manufacturer's instructions. If direct connected to the blower through a lubricated type coupling, the coupling should be checked and greased each time blower oil is changed. This will help reduce wear and prevent unnecessary vibration. In a belted drive system, check belt tension periodically and inspect for frayed or cracked belts.

In a new, and properly installed, unit there is no contact between the two impellers, or between the impellers and cylinder or headplates. Wear is confined to the bearings (which support and locate the shafts) the oil seals, and the timing gears. All are lubricated and wear should be minimal if clean oil of the correct grade is always used. Seals are subject to deterioration as well as wear, and may require replacement at varying periods.

Shaft bearings are designed for optimum life under average conditions with proper lubrication and are critical to the service life of the blower. Gradual bearing wear may allow a shaft position to change slightly, until rubbing develops between impeller and casing. This will cause spot heating, which can be detected by observing these surfaces. Sudden bearing failure is usually more serious. Since the shaft and impeller are no longer supported and properly located, extensive general damage to the blower casing and gears is likely to occur.

Oil seals should be considered expendable items, to be replaced whenever drainage from the headplate vent cavity becomes excessive or when the blower is disassembled for

any reason. Some oil seal leakage may occur since an oil film under the lip is required for proper operation. Periodically leaked oil should be wiped off from surfaces. Minor seal leakage should not be considered as indicating seal replacement.

Timing gear wear, when correct lubrication is maintained, should be negligible. Gear teeth are cut to provide the correct amount of backlash, and gears correctly mounted on the shafts will accommodate a normal amount of tooth wear without permitting contact between lobes of the two impellers. However, too high an oil level will cause churning and excessive heating. This is indicated by unusually high temperature at the bottom of the gear housing. Consequent heating of the gears will result in loss of tooth-clearance, backlash and rapid wear of the gear teeth usually will develop. Continuation of this tooth wear will eventually produce impeller contacts (knocking), and from this point serious damage will be unavoidable if blower operation is continued. A similar situation can be produced suddenly by gear tooth fracture, which is usually brought on by sustained overloading or momentary shock loads.

Problems may also develop from causes other than internal parts failure. Operating clearances within a blower are only a few thousandths of an inch. This makes it possible for impeller interference or casing rubs to result from shifts in the blower mounting, or from changes in piping support. If this type of trouble is experienced, and the blower is found to be clean, try removing mounting strains. Loosen blower mounting bolts and reset the leveling and drive alignment. Then tighten mounting again, and make sure that all piping meets blower connections accurately and squarely. Foreign materials in the blower will also cause trouble, which can only be cured by disconnecting the piping and thoroughly cleaning the blower interior.

A wide range of causes & solutions for operating troubles are covered in the **TROUBLE SHOOTING CHECKLIST**. The remedies suggested should be performed by qualified mechanics with a good background. Major repairs generally are to be considered beyond the scope of maintenance, and should be referred to an authorized Roots distributor.

Warranty failures should not be repaired at all, unless specific approval has been obtained through Roots before starting work. Unauthorized disassembly within the warranty period may void the warranty.

Figure 2 - Allowable Overhung Loads for V-Belt Drives Universal RAI®/URAI®-DSL Units

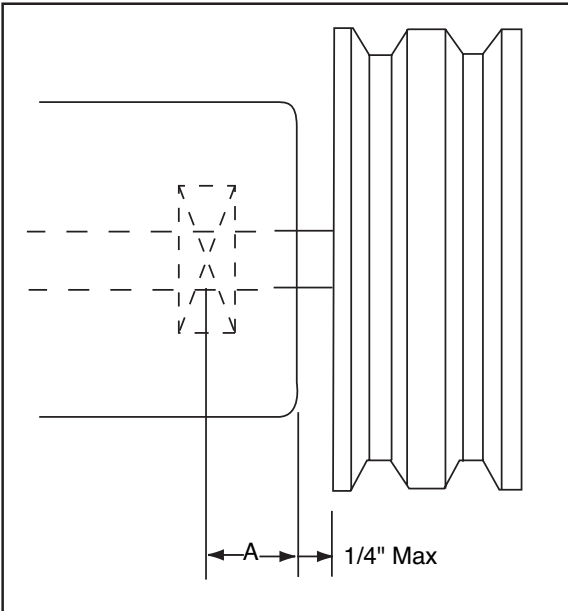

$$\text{Belt Pull lbs} = \frac{252100 \cdot \text{Motor HP}}{\text{Blower RPM} \cdot \text{Sheave Diameter}}$$

$$\text{Shaft Load (lb.in)} = \text{Belt Pull} \cdot \left(A + \frac{1}{4} + \frac{\text{Sheave Width}}{2} \right)$$

Frame Size	Dimension "A"	Max Allowable Shaft Load (lb-in)	Min Sheave Diameter
47	1.02	650	5.00

NOTE:

Arc of sheave belt contact on the smaller sheave not to be less than 170°

Driver to be installed on the inlet side for vertical units, and on the drive shaft side for horizontal units.

Roots recommends the use of two or more 3V, 5V or 8V matched set or banded belts and sheaves.

Specified Lubricants

ROOTS Synthetic Oil: ISO-VG-320 Grade

	Part Number
Quart	13106004
Gallon	13106005
Case (12 qts)	13106007

ROOTS Synthetic Oil: ISO-VG-220 Grade

	Part Number
Quart	13106001
Gallon	13106002
Case (12 qts)	13106008

ROOTS Synthetic Oil: ISO-VG-150 Grade

	Part Number
Quart	13106020
Gallon	13106021
Case (12 qts)	13106023
5 Gallon Pail	13106022
55 Gallon Drum	13106025

Drive End Breather Orientation for URA-DSL blowers with Oil Lube

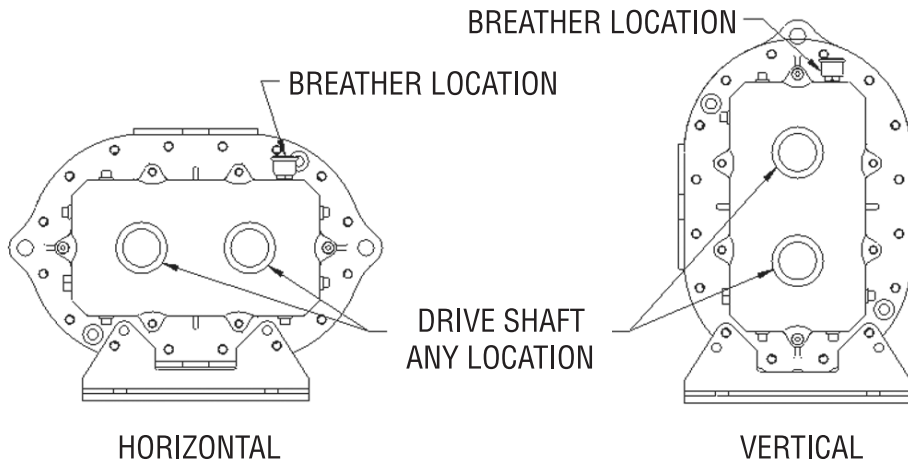

URAI DSL BREATHER ORIENTATION

Table 1 - URAI, URAI-DSL Blowers,
Maximum Allowable Operating Conditions

Frame Size	Gear Diameter (Inch)	Speed RPM	Temp. Rise Deg F (Deg C)	Delta Pressure PSI (mbar)	Inlet Vacuum INHG (mbar)
47	4	3,600	225 (125)	7 (483)	15 (500)

Table 2 - Recommended Oil Grades

Ambient Temperature °F (°C)	ISO Viscosity No.
Above 90° (32°)	320
32° to 90° (0° to 32°)	220
0° to 32° (-18° to 0°)	150
Below 0° (-18°)	100

Ambient temperature is defined as the temperature of the space in which the blower and drive are located.

Table 3 - Approximate Oil Sump Capacities

These capacities are provided to assist in stocking the correct amount of oil. Exact sump capacities may differ slightly. See "Lubrication" section for proper filling instructions.

URAI-DSL Splash Lubricated Blowers

Frame Size	Gear End Capacity Fl. Oz (Liters)	Drive End Capacity Fl. Oz. (Liters)
47	22.8 (.67)	10.8 (.32)

Basic Connection & Drive Shaft Information

URAI DSL AIR BLOWERS (with Dual Splash Lubrication DSL)

BOM#	FRAME SIZE	INLET/DISCHARGE CONN.	SHAFT DIAMETER	BARE WEIGHT
T30354020	47	3" NPT	.0875"	132

Universal RAI air blowers include detachable mounting feet which permit vertical or horizontal installation. The units are center timed for rotation in either direction. The bearings on the URAI are grease lubricated on the drive end and splash lubricated on the gear end. The URAI-DSL is splash lubricated on BOTH ends.

PAGE LEFT BLANK

WARRANTY RETURN GOODS POLICY

LIMITED WARRANTY

The Manufacturer warrants its products to be free from defects in material and workmanship for a period of twelve months from the date of shipment from the factory. The Manufacturer shall not be responsible for any damage resulting to or caused by its products by reason of installation, improper storage, unauthorized service, alteration of the products, neglect or abuse, or use of the product in a manner inconsistent with its design. The warranty does not extend to any component parts not manufactured by Manufacturer; however, Manufacturer's warranty herein shall not limit any warranties made by manufacturers of component parts which extend to Buyer.

Claims for defects in material and workmanship shall be made in writing to Manufacturer within ten days of discovery of defect. Manufacturer may either send a service representative or have the product returned to its factory at Buyer's expense for inspection. Upon notification of defect, Manufacturer will issue a return goods authorization number to Buyer. The return goods authorization number must accompany the product returned. If judged by the Manufacturer to be defective in material or workmanship, the product will be replaced or repaired at the option of the Manufacturer, free from all charges except authorized transportation. Buyer shall be responsible for all maintenance services consisting of lubrication and cleaning of equipment, replacing expandable parts, making minor adjustments, and performing operating checks, all in accordance with procedures outlined in Manufacturer's maintenance literature.

THE FOREGOING WARRANTY IS IN LIEU OF ALL OTHER WARRANTIES AND NO REPRESENTATIONS, GUARANTEES, OR WARRANTIES, EXPRESS OR IMPLIED, (INCLUDING BUT NOT LIMITED TO A WARRANTY OF MERCHANTABILITY OR FITNESS FOR A PARTICULAR PURPOSE), ARE MADE BY THE MANUFACTURER IN CONNECTION WITH THE MANUFACTURE OR SALE OF ITS PRODUCTS. NO EMPLOYEE, DISTRIBUTOR, OR REPRESENTATIVE IS AUTHORIZED TO CHANGE THIS WARRANTY ON BEHALF OF MANUFACTURER.

THE REMEDIES OF BUYER SET FORTH HEREIN ARE EXCLUSIVE AND ARE IN LIEU OF ALL OTHER REMEDIES. THE LIABILITY OF MANUFACTURER WHETHER IN CONTRACT, TORT, UNDER ANY WARRANTY, OR

OTHERWISE SHALL NOT EXTEND BEYOND ITS OBLIGATION TO REPAIR OR REPLACE, AT ITS OPTION ANY PRODUCT OR PART FOUND BY MANUFACTURER TO BE DEFECTIVE IN MATERIAL OR WORKMANSHIP. MANUFACTURER SHALL NOT BE LIABLE FOR COST OF INSTALLATION AND/OR REMOVAL OR BE RESPONSIBLE FOR DIRECT, INDIRECT, SPECIAL OR CONSEQUENTIAL DAMAGES OF ANY NATURE.

GENERAL RETURNS OF MERCHANDISE

1. All returns must be pre-authorized
 - A. Please call our parts department for an RGA number
 - B. Please include RGA number on the outside of box
 - C. Include any required paper work or special instructions
 - D. Items returned without an RGA number will not be accepted
2. All returns are subject to a 20% restock charge.
3. Special items are non-returnable
 - A. Non-stock parts
 - B. Custom parts
 - C. If you are unsure about a parts status when ordering, ask your McLaughlin representative if the item fits on of the above conditions.
4. Items must be returned within thirty days of original order date.
5. Items not returned within 30 days from the date of RGA is issued will not be accepted.
6. The item(s) must be in new condition. Used item(s) are not returnable.

