



McLAUGHLIN®

2006 Perimeter Road. Greenville, SC 29605
Toll Free: 800/435-9340 - Phone: 864/277-5870
Fax: 864/235-9661 - Website address: www.mightymole.com
Email address: mmole@mightymole.com

Parts Manual
Vermeer/ McLaughlin V750 Vacuum Machine
(Serial # V7S100410249 - V7S111512315)

© 2012 by McLaughlin Group, Inc.

080812

All rights reserved. No part of this manual may be reproduced in any form, or by any means without prior written permission of McLaughlin Group, Inc.

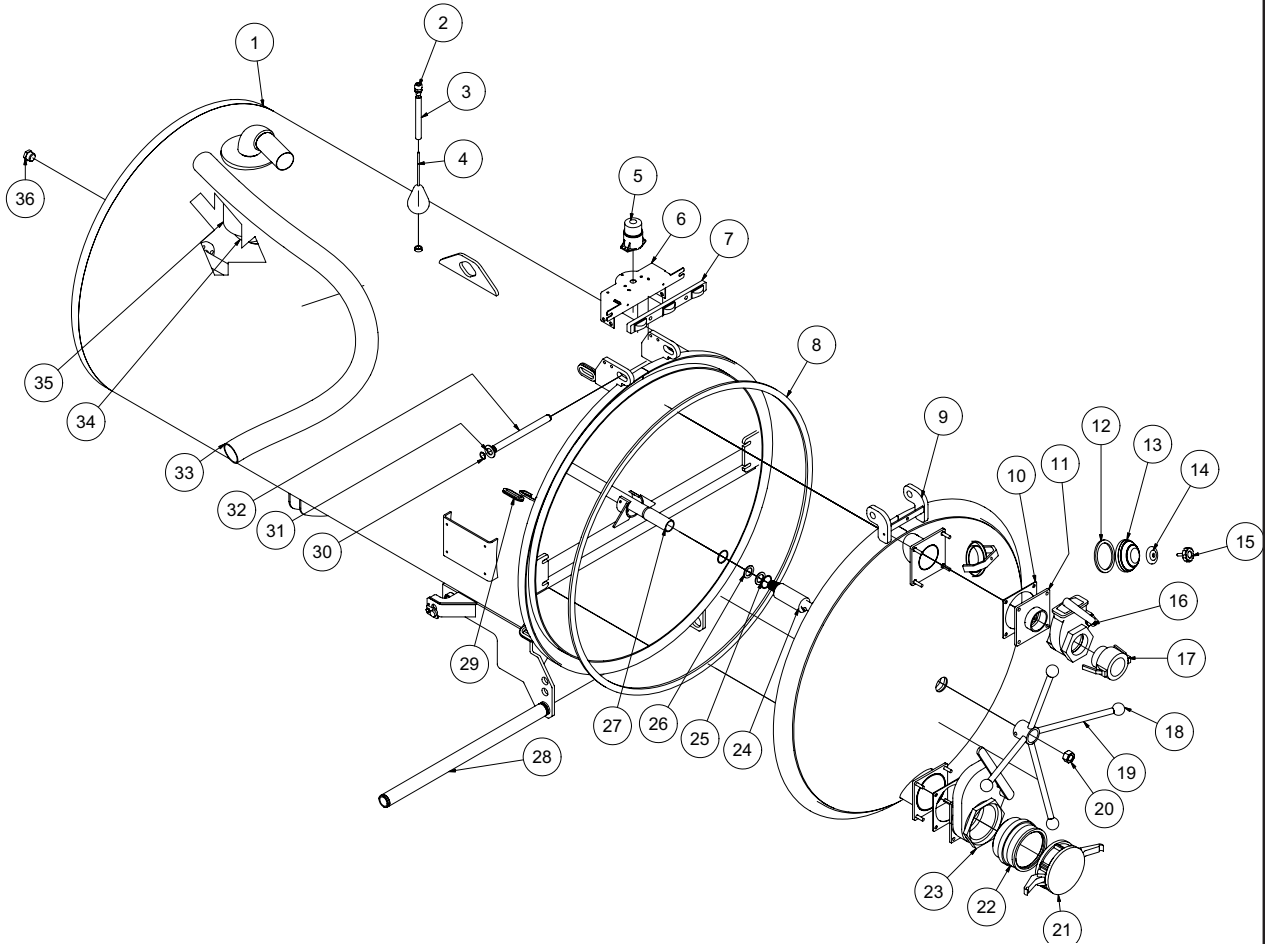

Table of Contents

PARTS	
SPOIL TANK AND FILTRATION	
MANUAL DOOR	4
FILTRATION	6
ENGINE COMPARTMENT	
ENGINE	8
BLOWER	10
ELECTRICAL	16
HYDRAULIC PUMP	18
TRAILER AND SKID ASSEMBLY	
TRAILER	20
SKID ASSEMBLY	22
TOOLS	
SUCTION TOOL	24
HOSES	26
MAINTENANCE MANUALS	
ROOTS BLOWER	29
WARRANTY	40

Tank and Door Assembly

V750



Tank and Door Assembly

V750

ITEM	QTY	PART NO.	DESCRIPTION
1	1	8046457	TANK WELD'T - 750 (48" DIA)
2	1	X000113	STRAIN RELIEF, 1/2"
3	1	8040769	HIGH LEVEL FLOAT SWITCH TUBE
	1	8041291	BUSHING,RUBBER
4	1	8030531	HIGH LEVEL FLOAT SWITCH
5	1	8043139	STROBE LIGHT
	3	U010006	SCREW, PHILLIPS #10 - 24 X 1"
	3	U210005	WASHER, LOCK #10
	3	U100010	NUT, HEX #10 - 24
6	1	8046507	STROBE LIGHT BRACKET
	4	U000880	SCREW, HC 1/2" - 13 X 2.00"
	4	U200100	WASHER, FLAT 1/2"
	4	U210111	WASHER, LOCK 1/2"
	4	U100120	NUT, HEX 1/2"-13
	1	X000343	DT MOUNTING CLIP
7	1	8041509	LIGHT CLEARANCE 3 BAR
8	1	8041766	SEAL, DOOR SQ V750/V800LE 154"
9	1	8040709	750 DOOR - WELDMENT (48")
10	2	8046191	GASKET, INLET/OUTLET DOOR LE
11	1	8046197	GATE VALVE TANK FLANGE 3"
12	1	8032007	GASKET, 4" COUPLER
13	1	8031048	SIGHT GLASS
14	1	8031047	SIGHT GLASS PLATE
15	1	8031046	SIGHT GLASS HAND WHEEL
16	1	8042408	3" GATE VALVE
17	1	8041585	COUPLING, PP 3"CAM X 3"MNPT
18	4	J400060	1 7/8" KNOB
19	1	8040235	DOOR HANDLE, 250-1200
20	1	U120060	NUT, LOCK NY 1"-8
21	1	8041584	CAP, AL 6" FCAM
22	1	8041583	COUPLING, AL 6"MCAM X 6"MNPT
23	1	8046214	VALVE, 6" GATE BRASS LEVER FLANGE
	1	8030849-50	HANDLE,6"GATE VALVE(RIV MODEL)
24	1	8040306	Q.L. DOOR STRIKER
25	2	W200120	O-RING 1 7/8" X 2 1/8" X 1/8" (225)
26	2	8030174	WASHER, DOOR HOLDER Q.L.
27	1	8040729	TANK ROD WELDMENT - 750MS
28	1	8042538	TANK PIVOT ROD
29	3	8042812	GROMMET 2"ID 3"OD 1/4"WOG TRAILER SLOT MODEL
30	2	U500020	1" SNAP RING
31	2	U200171	WASHER FLAT 1.000 ZP SAE
32	1	8040058	DOOR HINGE ROD
33	1	8045298	HOSE VAC KANAFLEX 3-64"
34	1	8043570	BALL STRAINLESS FLOAT 6"
35	1	8043700	BALL FLOAT SHUTOFF WELDMENT
	2	U000420	SCREW, HC 3/8"-16 X 1.00"
	2	U210060	WASHER, LOCK 3/8"
	2	U200600	WASHER, FLAT 3/8"
	1	8043571	SEAT 4" RUBBER
	1	8043572	SEAT CLAMP 4"
36	1	T405120	1" PLUG MB

* NOT SHOWN

Filtration

750

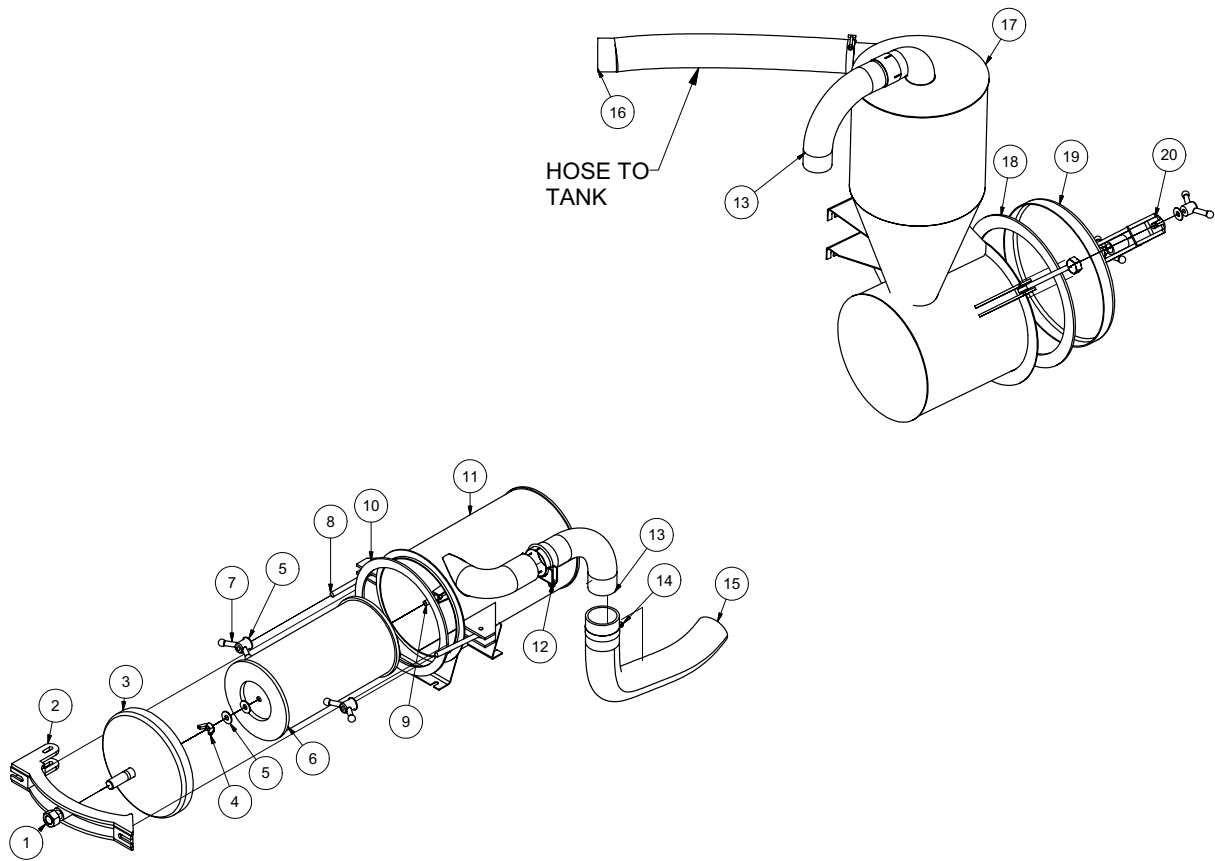

Filtration

750

ITEM	QTY	PART #	DESCRIPTION
1	2	U120060	NUT, LOCK NY 1" - 8
2	1	8044622	DOOR LATCH (AIR FILTER) - WELDMENT
3	1	8044620	575 RF AIR FILTER DOME
4	1	U130080	NUT, WING 1/2 - 13
5	6	U200100	WASHER, FLAT 1/2"
6	1	8031178	FILTER, ELEMENT 575CFM
7	4	8041594	Y-HANDLE
8	4	8041593	EYE BOLT
9	1	8040302	THREADED ROD - 4"LG
10	1	8044819	GASKET, REV FLOW AIR FILTER 575
11	1	8044596	AIR FILTER 575
	4	U000420	SCREW, HC 3/8"-16 X 1.00
	8	U200600	WASHER, FLAT 3/8"
	4	U210061	NUT, HEX NY 3/8"-16
12	1	8030395	3" U-BOLT CLAMP
13	2	8040682	ELBOW, 3" (6"RAD, ID-OD)
14	4	8042605	CLAMP, T-BOLT 3" (350)
15	1	8046810	HOSE VAC KANAFLEX 3-146"
16	1	8045298	HOSE VAC KANAFLEX 3-64"
17	1	8044589	CYCLONE 575 REV FLOW
	4	U000420	SCREW, HC 3/8"-16 X 1.00"
	4	U200600	WASHER, FLAT 3/8"
	4	U210060	WASHER, FLAT 3/8"
18	1	8041612	GASKET, REV FLOW CYCLONE
19	1	8041402	HD CYCLONE DOME DOOR ASSEMBLY
20	1	8041552	DOOR LATCH (CYCLONE) - WELDMENT

Engine Honda GX660TAF

V750G

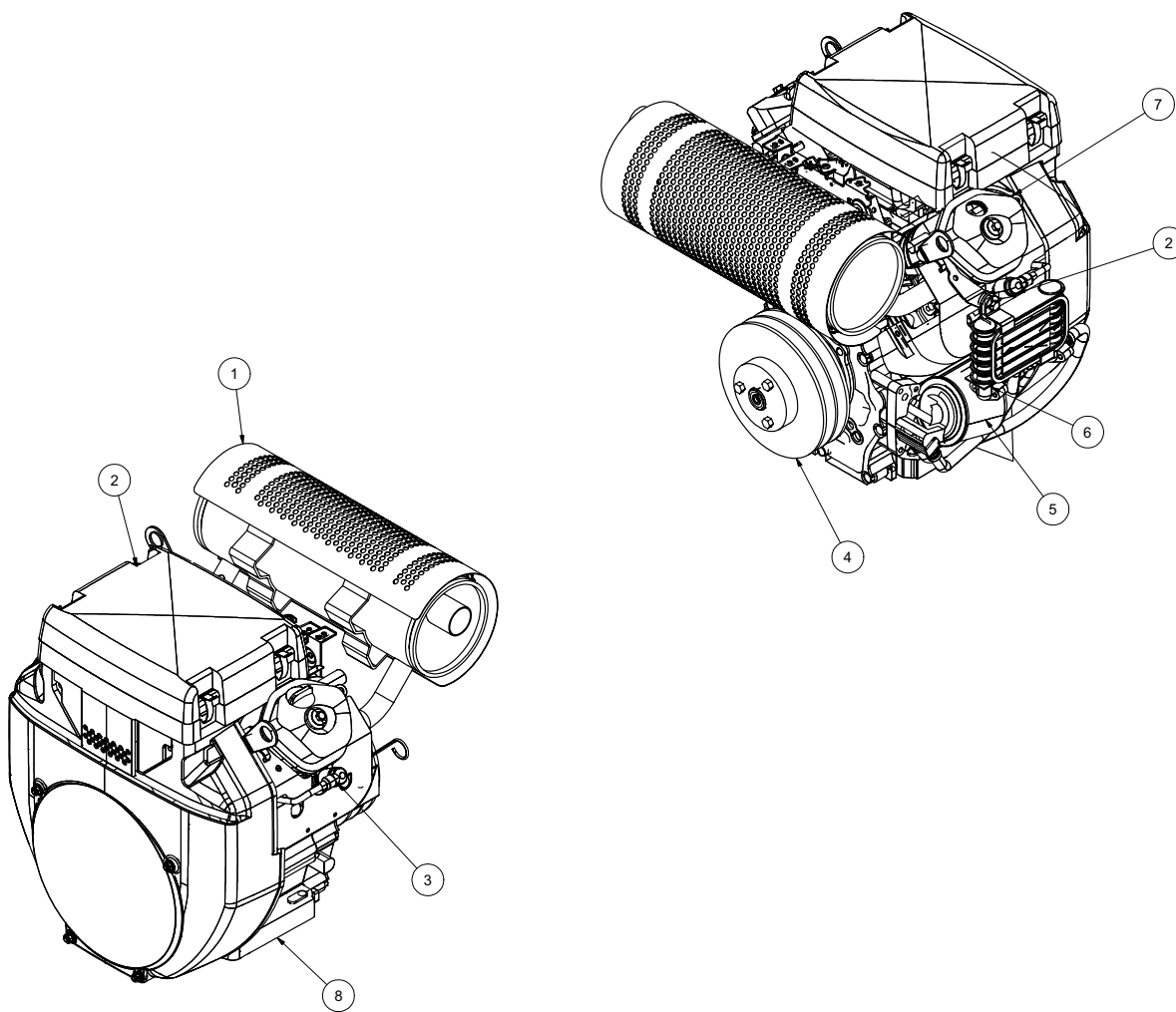

Engine Honda GX660TAF

V750G

ITEM	QTY	NUMBER	DESCRIPTION
1	1	8046015	MUFFLER, L.H.
	2	8046015-1	MUFFLER, EXHAUST GASKET L.H.
	2	8046015-2	MUFFLER, EXHAUST NUT L.H.
2	1	8046019	FILTER, AIR ELEMENT
3	2	8046018	SPARK PLUG
4	1	8040697	SHEAVE, 6.55"OD SDS 2-GROOVE
	1	8040485	BUSHING, 1 1/8" SDS
	1	8042719	FILTER, OIL
6	1	8046019	OIL COOLER
7	1	8046014	FUEL FILTER
8	1	8046017	ENGINE, HONDA 24HP GX660
	1	8046020	IGNITION KEY
	4	U000560	SCREW, HC 3/8-16 X 3.00"
	4	U100060	NUT, HEX 3/8"-16
	4	U210060	WASHER, LOCK 3/8"
	4	U200600	WASHER, FLAT 3/8"
*	1	8030689	MANUAL BOX
*	1	T400041	UNION, 3/8" MJ-M14 MALE W/SEAL
*	1	8043846	HOSE ASSY VAC 6-10 ST-90

* Not Shown

Blower Assembly

750

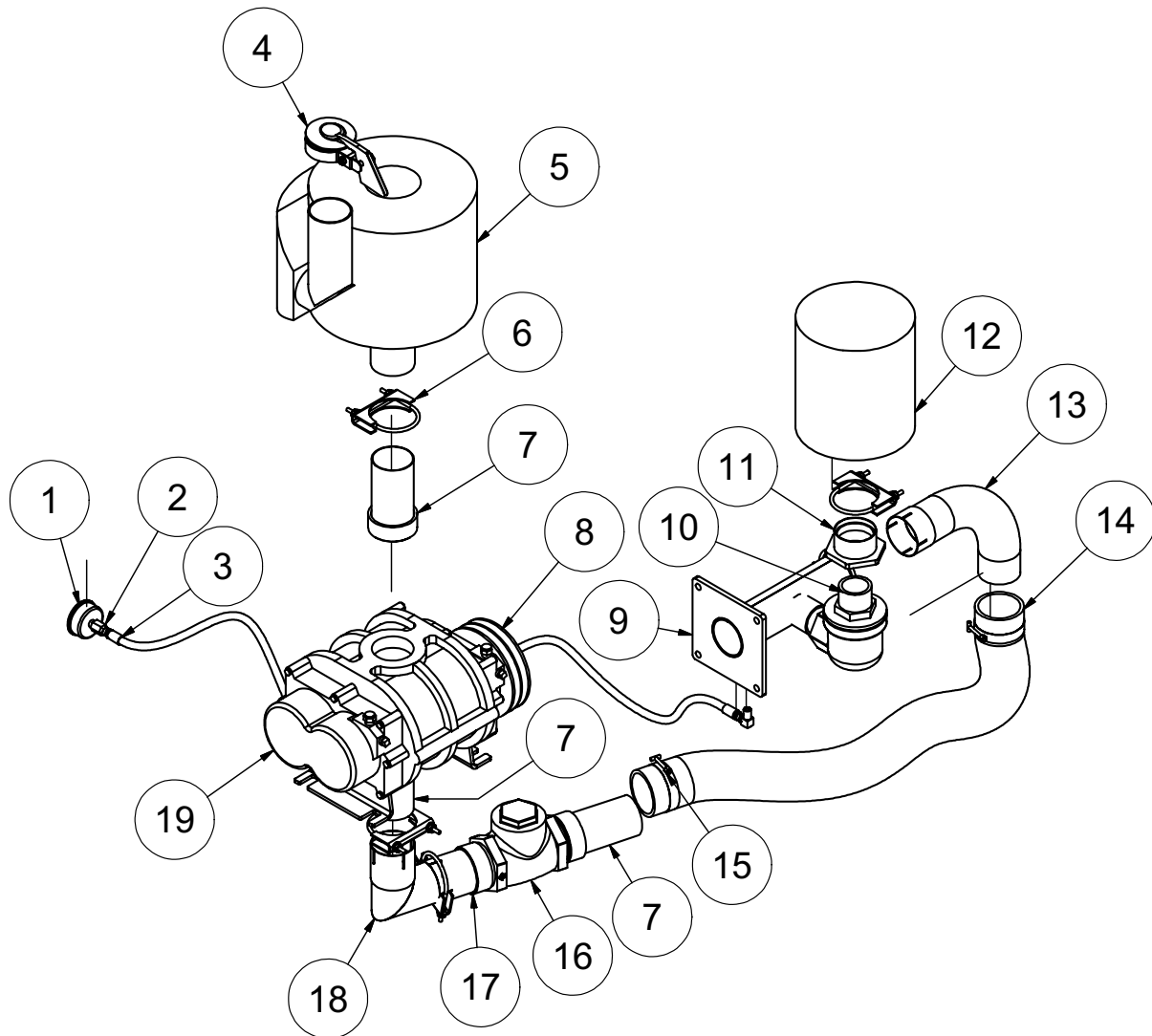

Blower Assembly

750

ITEM	QTY	PART NO.	DESCRIPTION
1	1	8041074	VACUUM GAUGE
2	1	T400110	UNION, 4FP-4MJ
3	1	8045843	HOSE ASSY VAC 4-62" ST-ST
4	1	8044537	3" RAIN CAP SILENT
5	1	8030332	SILENCER, 500CFM, COWL
6	4	8030395	3" U-BOLT CLAMP
7	2	8045238	UNION EXHAUST 3" OD-MNPT
8	1	8040484	SHEAVE 6.95" OD SDS 2-GROOVE
	1	8040642	BUSHING 7/8" SDS
	1	U410042	KEY, 3/16" X 3/16" X 2"
	1	8041797	RETAINER
	2	8041812	BX52 BELTS
9	1	8046519	3" HEADER AIR FILTER HDRF
10	1	8030337	BAYCO VALVE 575CFM
11	1	8044951	VACUUM RELIEF FILTER BUSHING
12	1	8043553	FILTER AIR 3" 245CFM
13	1	8040682	ELBOW, 3" (6" RAD, ID-OD)
14	1	8041445	HOSE VAC KANAFLEX 3-36"
15	2	8042605	CLAMP T-BOLT 3" (350)
16	1	8040799	CHECK VALVE 3" FNPT - MODIFIED
17	1	8044639	3" MP - 3"ID EXHAUST ADAPTER
18	1	8045637	3" EXHAUST ELBOW TIGHT 90 ID-OD WELDMENT
19	1	8041250	BLOWER ASSEMBLY (MODEL 47)
	4	U000817	SCREW, HC 1/2"-13 X 1.00"
	4	U210100	WASHER, LOCK 1/2"
	4	U200100	WASHER, FLAT 1/2"

Blower Assembly

750RF

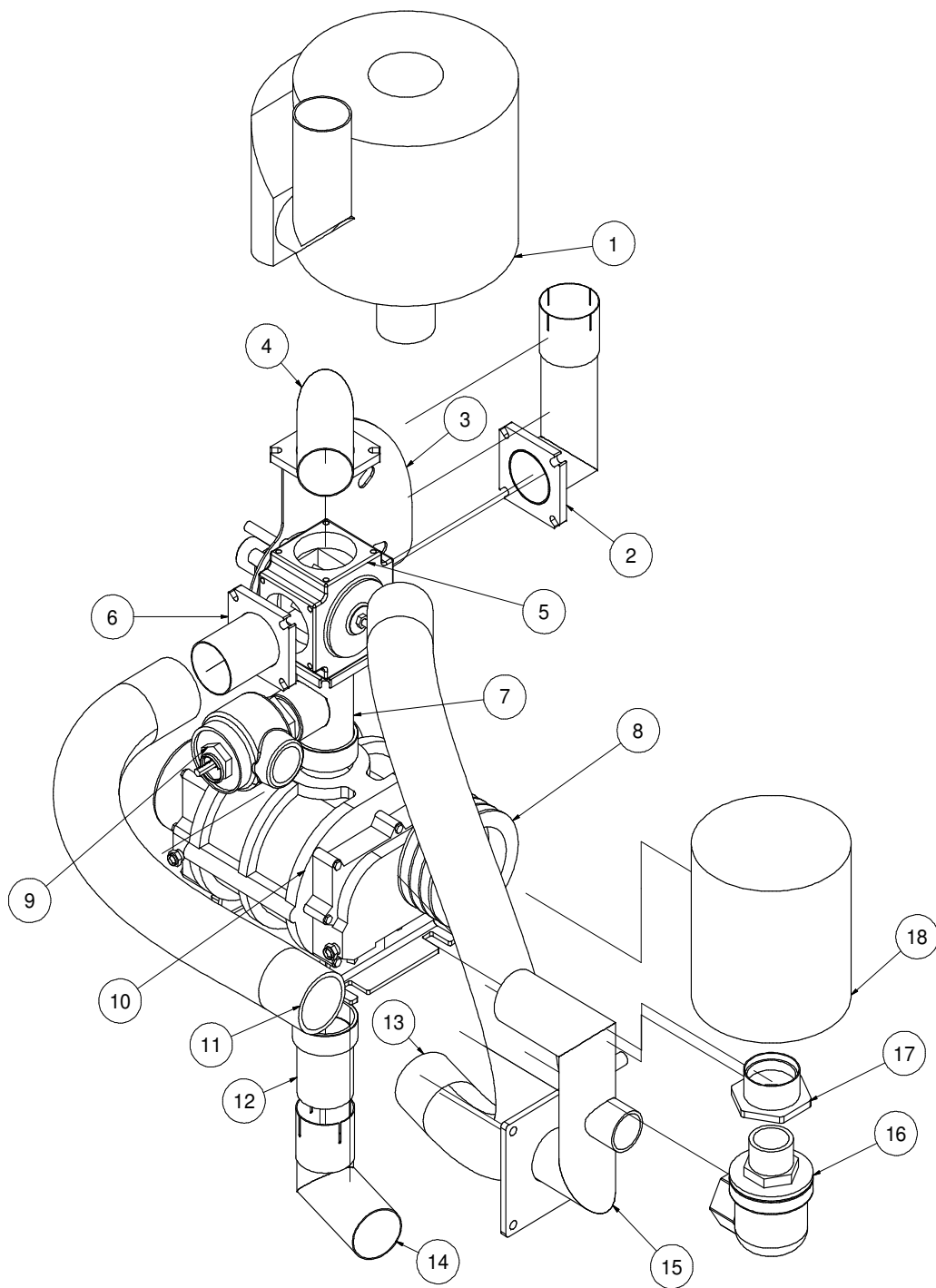

080812-E

VACASSY242

Blower Assembly

750RF

ITEM	QTY	NUMBER	DESCRIPTION
1	1	8030332	SILENCER, 500CFM, COWL
2	1	8046656	ELBOW, 90 SHARP, 3"OD-ID W/FLANGE
3	1	8046078	REV FLOW HANDLE FACE PLATE
4	1	8046658	ELBOW, 3" 90 4.5"LG X 5.5"LG W/FLANGE
5	1	8041030	3" 4-WAY VALVE W/O FLANGE
6	1	8046504	EXHAUST 3" FLANGE X 3" TUBE WELDMENT
7	1	8046654	ADAPTER 4-WAY VALVE 3" TO BLOWER
8	1	8040484	SHEAVE, 6.95"OD SDS 2-GROOVE
	1	8040642	BUSHING 7/8" SDS
	1	U410042	KEY, 3/16" X 3/16" X 2"
	1	8041797	RETAINER
	2	8041812	BX52 BELTS
9	1	8041034	PRESSURE RELIEF VALVE
10	1	8041250	BLOWER ASSEMBLY (MODEL 47)
	4	U000817	SCREW, HC 1/2"-13 X 1.00"
	4	U210100	WASHER, LOCK 1/2"
	4	U200100	WASHER, FLAT 1/2"
11	1	8048413	HOSE VAC AG SUCTION 3-31 1/2"LG
12	1	8046420	HOSE ADAPTER 3" HOSE - 3"MP
13	1	8046825	HOSE VAC AG SUCTION 3-48"LG
14	1	8045637	3" EXHAUST ELBOW TIGHT 90 ID-OD
15	1	8046657	3" HEADER AIR FILTER HDRF
16	1	8030337	VALVE, 2" AIR RELIEF
17	1	8044951	VACUUM RELIEF FILTER BUSHING
18	1	8043553	FILTER, AIR 3" 245CFM

REV.	PART NAME	DATE	BY	APP.

- NOTES:
- A- INSTALL ITEM #20 (SCREW) IN ASSEMBLY
 - C- 3-1/2 REQ'D SOC. HD. ON G.E. AND D.E.
 - E- REQ'D ON 42 ONLY
 - F- NUT TO BE TORQUED TO:
 3-1/2---110 LB.FT.
 4-----190 LB.FT.
 5-----250 LB.FT.
 - G- USE RED LOCKTITE ON SET SCREW THREADS.

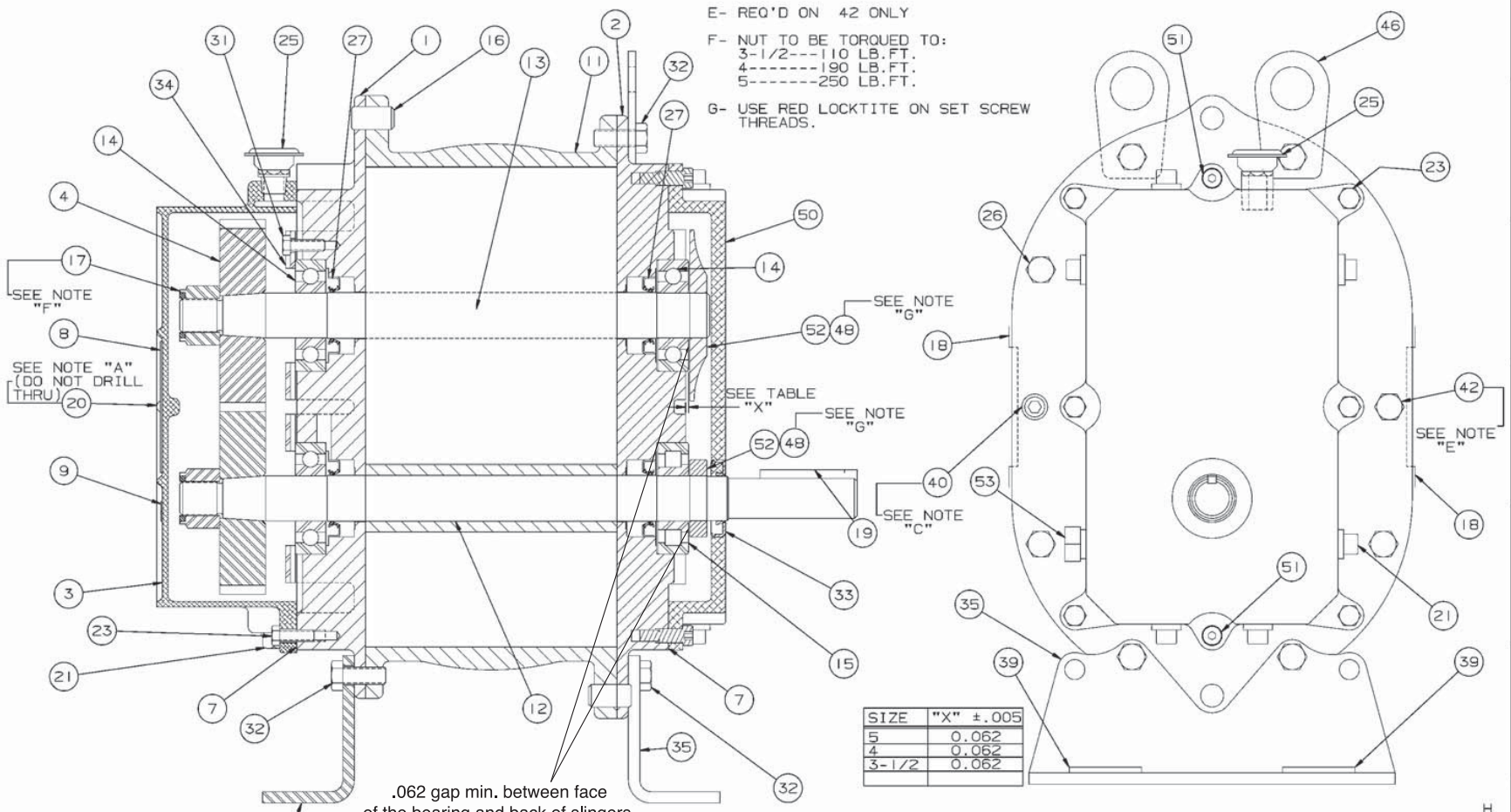

SIZE	"X" ±.005
5	0.062
4	0.062
3-1/2	0.062

.062 gap min. between face of the bearing and back of slingers.

CONFIDENTIAL THIS DOCUMENT CONTAINS CONFIDENTIAL INFORMATION OF DRESSER ROOTS. DRESSER, INC. IT SHALL BE HELD IN STRICTLY CONFIDENTIAL AND BE USED ONLY IN CONNECTION WITH DRESSER ROOTS BUSINESS.		DATE: 04-04-05 DRAWN: JC-04-05 APP. ASST: JC-04-05 DWG. NO.: T30356023	ALL DIMENSIONS UNLESS OTHERWISE SPECIFIED ARE IN INCHES. SECTIONAL ASSEMBLY 3-1/2 THRU 5" U-RAI DSL BLOWERS SCALE: FULL DRESSER ROOTS Dresser Roots, Dresser, Inc., Houston, TX, USA
REV. 1: BLOWN 2: ANALYTICAL 3: FINISHING 4: TIME POSITION 5: STRENGTHENED	6: CONFIDENTIALITY 7: PROFILE OF LINE 8: PROFILE OF A SURFACE 9: DIAMETER 10: FINISH IN MICRO INCHES	REVISIONS: 1. REMOVED ELSON FROM BREATHER & NOTE "M" 2. 05/04/05 3. 07/11/05 4. 07/27/05 5. 08/04/05 6. 08/04/05	T30356023 REV A

Assembly of URAI DSL Blowers with Splash Lubricated Drive End 3-5" Gear Diameter

**URAI-DSL Splash Lubricated Blowers
4" Gear Diameter**

Item #	Qty	Part #	Description
1	1	8041250-1	Headplate Gear End
2	1	8041250-2	Headplate Drive End
3	1	8041250-3	Gearbox
4	2	8041250-4	Timing Gears
7	1	8041250-7	Gasket, Gear Box, DE Cover
11	1	8041250-11	Cylinder
12	1	8041250-12	Impeller & Shaft Drive
13	1	8041250-13	Impeller & shaft Driven
14	3	8041250-14	Bearing, Ball
15	1	8041250-15	Bearing, Roller
16	4	8041250-16	Pin, Dowel
17	2	8041250-17	Gear Nut
19	1	8041250-19	Key
21	3	8041250-21	Plug, Pipe
23	6	8041250-23	Screw Hex
25	1	8041250-25	Breather (Plug Vent)
26	*	8041250-26	Screw, Hex
27	4	8041250-27	Seal, Lip Bearing
31	4	8041250-31	Screw, Hex, Nylock
32	6	8041250-32	Screw, Hex
33	1	8041250-33	Seal Lip-Drive
34	2	8041250-34	Clamp Plate
35	2	8041250-35	Foot
39	4	8041250-39	Washer Mounting
40	2	8041250-40	Screw Socket
42	2	8041250-42	Screw Hex
48	4	8041250-48	DE Oil Slinger Set Screw
50	1	8041250-50	Drive End Cover
52	2	8041250-52	Drive End Oil Slinger
53	2	8041250-53	Oil Sight Glass

*Quantities vary by blower.

Control Panel 750MS

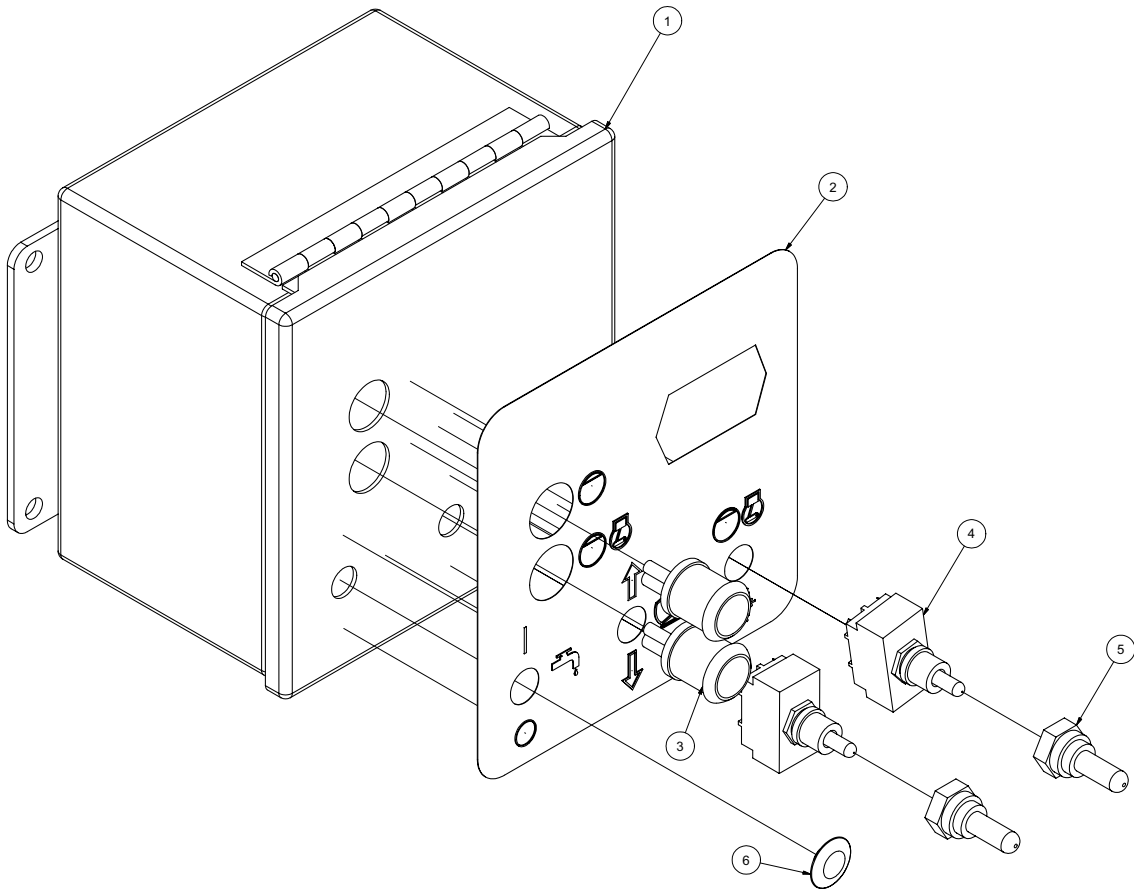
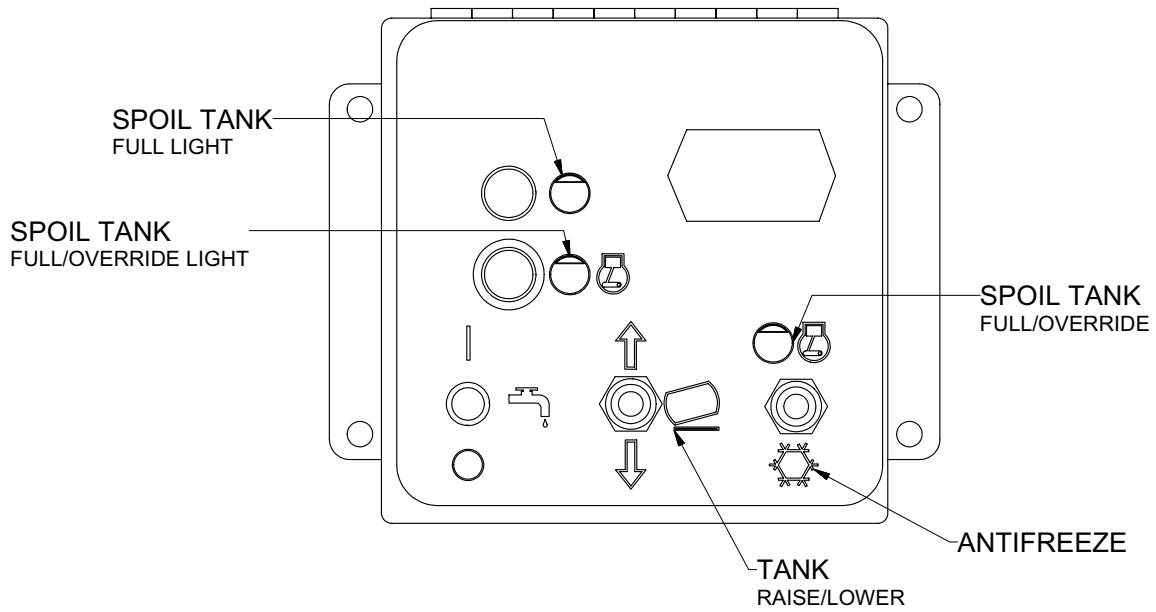

Control Panel 750MS

ITEM	QTY	PART NO.	DESCRIPTION
1	1	8046628	CONTROL BOX
2	1	J200028	DECAL, CONTROL PANEL 31LEG
3	2	8030457	PANEL LIGHT
4	2	8041077	SWITCH, TOGGLE TANK RAISE/LOWER
5	2	X000094	RUBBER BOOT
6	1	8041824	PLUG, PLASTIC PANEL 1/2"
*	3	8040184	RELAY SOCKET
*	3	8040185	RELAY
*	1	8030826	IN-LINE FUSE HOLDER
*	1	X130012	20AMP FUSE

* NOT SHOWN

Hydraulic Pump

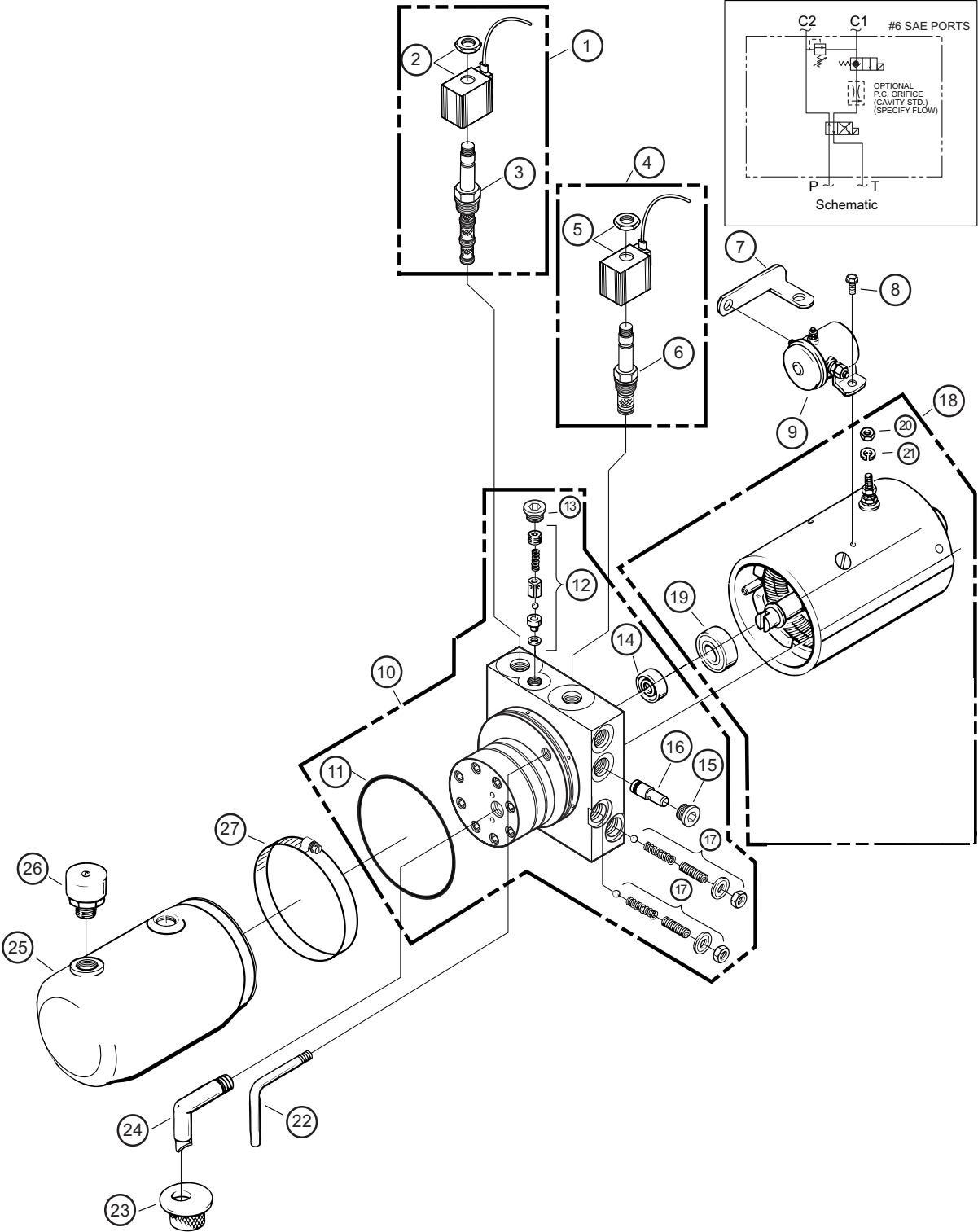

Hydraulic Pump

ITEM	QTY	NUMBER	DESCRIPTION
	1	8040486	HYDRAULIC PUMP 12V 3QT
		8041601	HYDRAULIC PUMP 12V 6QT (HYDRAULIC DOOR OPTION)
	2	U000420	SCREW, HC 3/8"-16 X 1
	2	U210060	WASHER, LOCK 3/8"
	2	U200600	WASHER, FLAT 3/8"
	2	T400037	UNION 6MB-6MJR
	2	8040973	HOSE ASSY VAC 6-20 ST-90
	2	T400391	BULKHEAD 6MP 6MP
1	1	8041601-14	VALVE, 4 WAY - 2 POSITION (12V)
2	1	8041601-15	COIL, 10 VDC GROUNDED W/DEUTSCH CONN
3	1	8041601-16	CARTRIDGE, 4 WAY - 2 POSITION
4	1	8041601-17	VALVE, 2 WAY - 2 POSITION (12V) GROUNDED
5	1	8041601-18	COIL, 10 VDC, 2 WAY-2 POS GRND W/DEUTSCH CONN
6	1	8041601-19	VALVE 12V HYD 2 WAY-2 POS
7	1	8041601-20	STRAP, MOTOR SOLENOID CONNECTING
8	2	8041601-21	SCREW, RND HD MACH 10-32 X 1/4"
9	1	8041601-22	SWITCH, SOLENOID 12VDC, 3 POST GRND
10	1	8041601-23	PUMP ASSY
11	1	8041601-24	O-RING INDUST 3-5/8 X 3-7/8 X 1/8
12	1	8041601-25	PARTS KIT-VALVE ASSY, POPPET/BALL CHECK
13	1	8041601-26	PLUG
14	1	8041601-27	SEAL
15	1	8041601-28	PLUG, #8 SAE
16	1	8041601-29	VALVE, PRESS, COMP ORIFICE
17	2	8041601-30	PARTS KIT, RELIEF VALVE
18	1	8041601-31	MOTOR, ELECTRIC 12 VDC
19	1	8041601-32	BEARING, BASE, MOTOR
20	1	8041601-33	NUT, HEX 5/16-24
21	1	8041601-34	WASHER, LOCK 5/16"
	2	8041601-38	SCREW, HEX HEAD, 1/4-20 X 1-3/8"
	1	8041601-41	PLUG, 3/8" NPTF
22	1	8041601-42	TUBE, RETURN (1/8")
23	1	8041601-43	SCREEN, FILTER (SUCTION)
24	1	8041601-44	TUBE, FILTER SUCTION 3/8 NPT 90 DEG
25	1	8041601-45	6QT RESEVOIR POLY
	*	8040486-45	3QT RESEVOIR POLY
26	1	8041601-46	PLUG, VENT, 3/8" NPT
27	1	8041601-47	CLAMP, HOSE WORM GEAR (IN SERIES)
*	1	X200002	HYDRAULIC PUMP WIRE HARNESS

* NOT SHOWN

Skid Assembly

V750MS

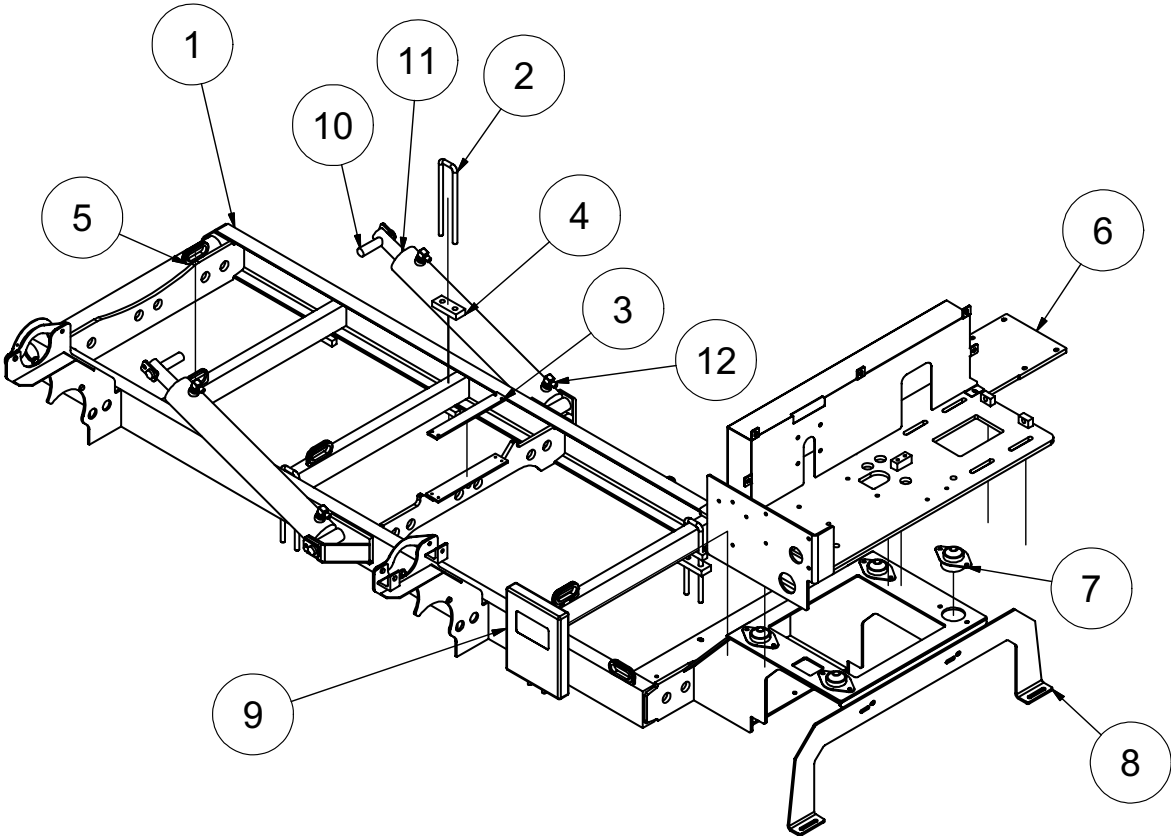

Skid Assembly

V750MS

ITEM	QTY	PART #	DESCRIPTION
1	1	8046462	TANK SKID WELDMENT - 750MUDSUCKER
2	6	8040038	U-BOLT, 1/2" - 13 X 10"LG - 1 5/8" GAP GR. 8
3	1	8045787	SKID FLAT TANK SEAT
4	6	8040240	U-BOLT MOUNTING BLOCK
5	7	8042812	GROMMET 2"ID 3"OD 1/4"WOG TRAILER SLOT MODEL
6	1	8045274	MAIN PLATE 24HP 750 MS - WELDMENT
	1	8045303	GUARD BASE PANEL
	1	8045304	GUARD ACCESS PANEL
7	4	8030904	ISOLATOR 840LB
	4	U000560	SCREW, HC 3/8" - 16 X 3"
	4	8030851	WASHER SNUBBLING
	4	U120110	NUT, LOCK 3/8"
	8	U000420	SCREW, HC 3/8" - 16 X 1"
	24	U200060	WASHER, FLAT 3/8" - 16
	8	U210060	WASHER, LOCK 3/8"
	8	U100060	NUT, HEX 3/8" - 16
8	1	8045245	BRACKET SUBFRAME STIFFENER LEG
9	1	E250210	BOX, PLASTIC FOR SAFETY MANAUL
10	4	8043844	CYLINDER PIN FLANGED 1"X5-1/2"
11	2	8030359	SPOIL TANK CYLINDER
12	4	T401270	ELBOW, 90 1/2"MB - 3/8"MJ
*	1	8041442	HOSE ASSY VAC 6-63" ST-90
*	1	8043301	HOSE ASSY VAC 6-56" ST-ST
*	1	8041453	HOSE ASSY VAC 6-89" ST-90
*	1	8043302	HOSE ASSY VAC 6-78" ST-ST
*	1	8045300	AIR FILTER BRACKET
*	1	X400050	BATTERY 31MHD

* NOT SHOWN

Trailer Assy 712

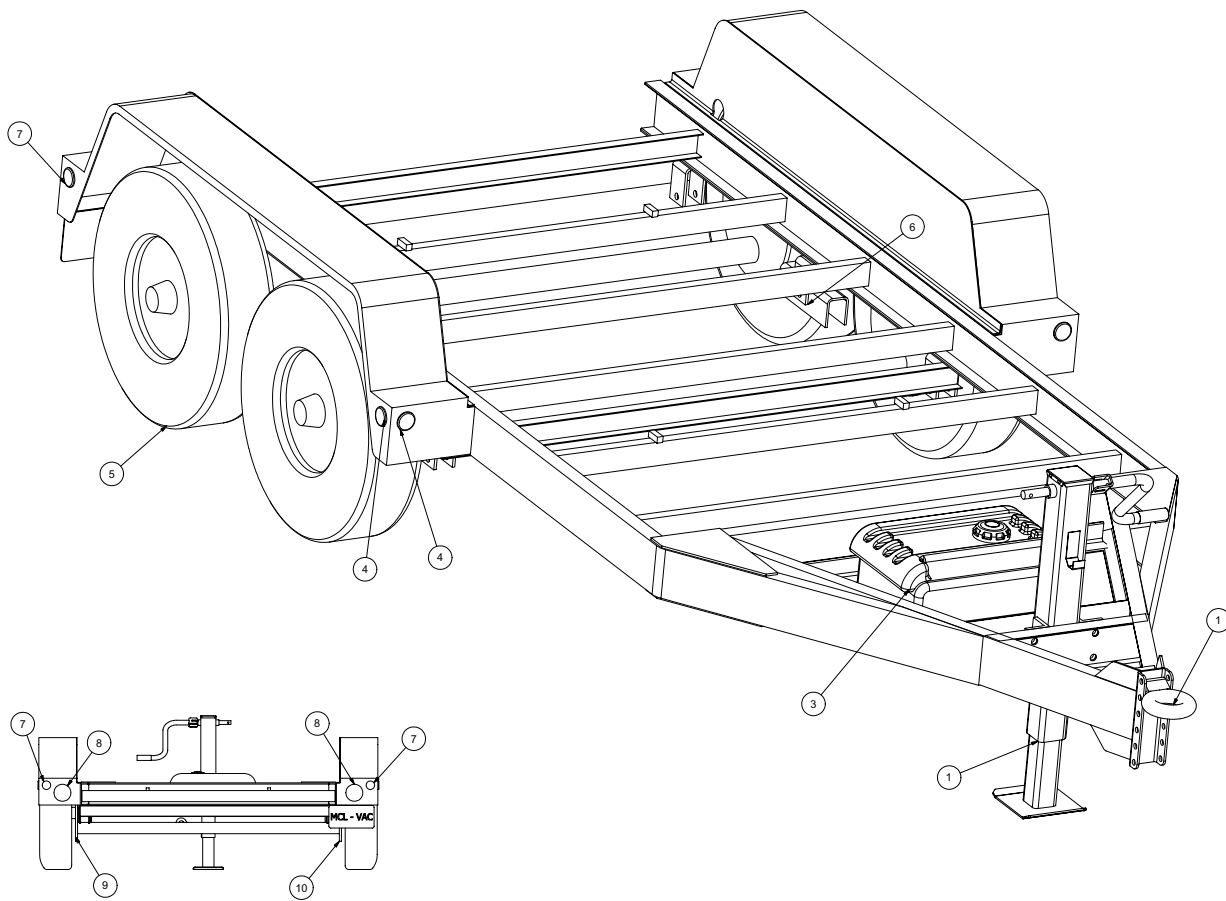

Trailer Assy 712

ITEM	QTY	PART #	DESCRIPTION
1	1	8043980	PINTLE EYE
2	1	8043548	JACK-MANUAL
	1	8043984	JACK HANDLE
3	1	8042381	TANK, FUEL PLASTIC 14GAL GAS
	1	8042381-1	TANK, FUEL CAP
	4	U000060	SCREW, HC 1/4-20 X 1.00"
	4	U200020	WASHER, FLAT 1/4"
4	4	8044000	2" YELLOW MARKER LIGHT
	4	8044002	2" RUBBER GROMMET
5	4	8045151	TIRE, ST 235/80 R16
	4	8045152	WHEEL, R16 X 6
	2	8045153	DROP AXLE
	4	8043986	HUB
	24	8043987	LUG NUT
	4	8047428	GREASE CAP
6	4	8043995	SPRING
	8	8043996	U-BOLT
	8	8043997	U-BOLT NUT
	4	8043998	TIE PLATE
7	4	8043999	2" RED MARKER LIGHT
	4	8044002	2" RUBBER GROMMET
8	2	8044001	4" STOP/TURN LIGHT
	2	8044003	4" GROMMET
9	1	8043990	LH BRAKE ASSEMBLY
	2	8043992	MAGNET KIT
	2	8043993	SHOE KIT
	1	8043994	ADJUSTER KIT
10	1	8043991	RH BRAKE ASSEMBLY
	2	8043992	MAGNET KIT
	2	8043993	SHOE KIT
	1	8043994	ADJUSTER KIT
*	1	8046992	TIRE, SPARE

Tools

3" Suction Tool

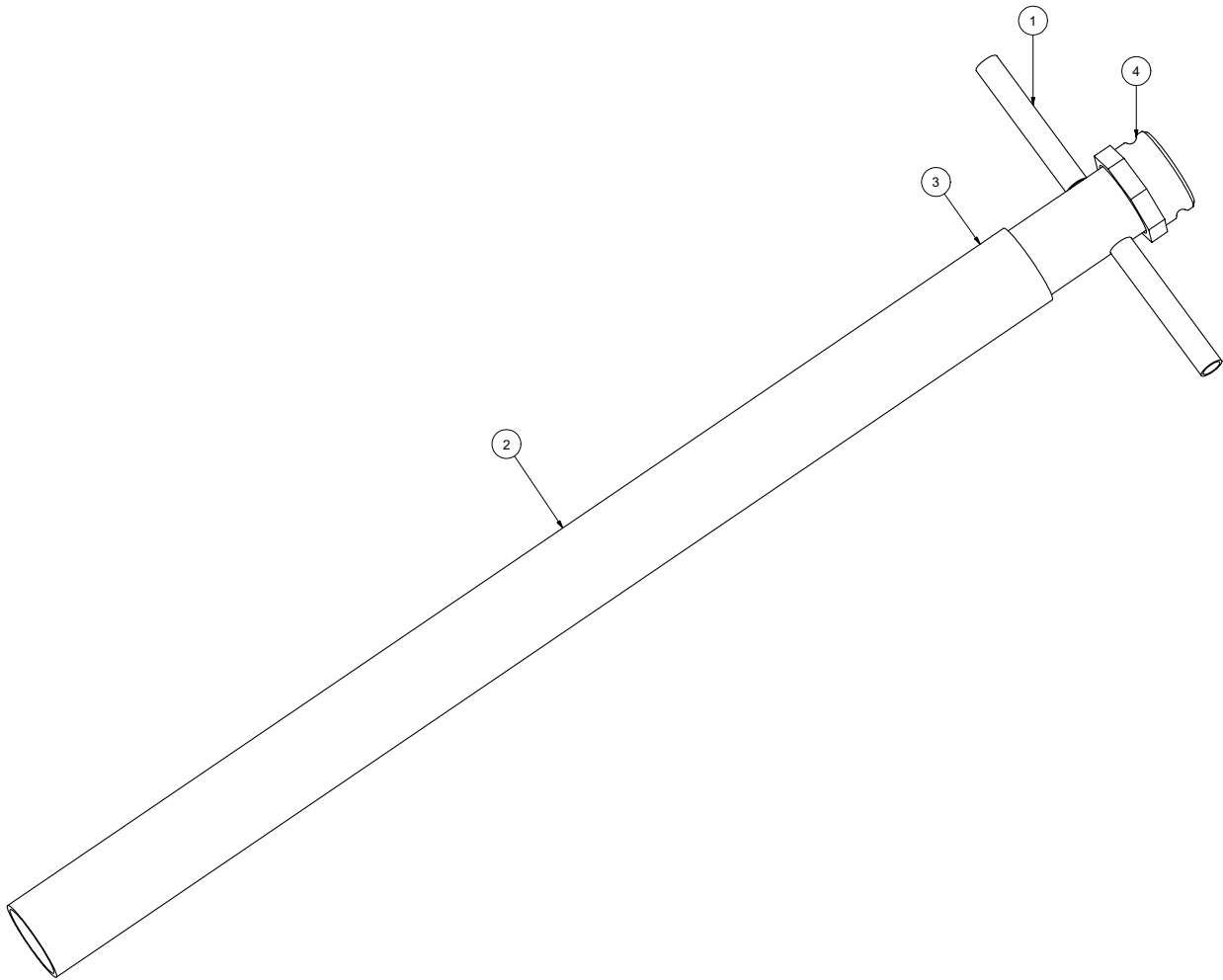

Tools

3" Suction Tool

ITEM	QTY	NUMBER	DESCRIPTION
	1	8030215	TOOL VAC SUCTION 3" COMPLETE
1	1	8030317	TOOL VAC HANDLE ASSEMBLY 3"
2	1	8030313	PVC VACUUM TUBE 3"
3	1	8030356	CLAMP,4"PUNCHLOCK P16-S
4	1	8030391	COUPLING, 3" BANJO

HOSES

3"

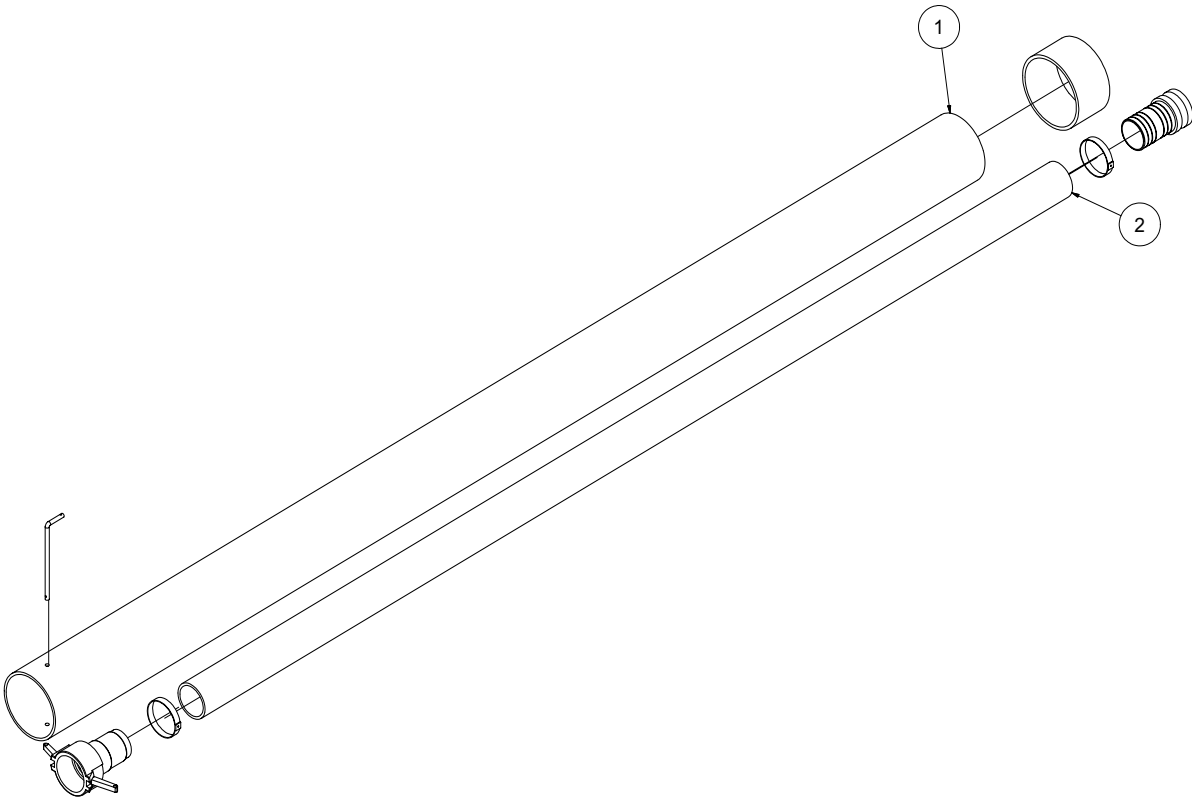

HOSES

3''

ITEM	QTY	PART NO.	DESCRIPTION
1	1	8041102	6" PVC STORAGE TUBE 10' LG
	1	8030925	END CAP 6"
	1	8041485	LANYARD CABLE
	1	8043198	HOSE STORAGE CLAMP
	2	U200060	WASHER. FLAT 3/8"
	2	U100060	NUT, HEX 3/8"
	1	8041101	HOSE STORAGE RETAINING ROD
	1	R700170	R-CLIP, 1/2 - 5/8 SHANK
2	1	8040338	HOSE VAC KANAFLEX 3-110"
	1	8046441	CAMLOCK, 3" AL FCAM X M BARB
	1	8046440	CAMCOCK, 3" AL MCAM X M BARB
	2	8030356	CLAMP, 4.5" PUNCHLOCK P18-S

PAGE LEFT BLANK

ROOTS

Blowers Compressors Exhausters

US \$3.00, Canada \$4.50

Universal RAI® and URAI DSL Blowers

Contents

Information Summary	1	Inspection & Maintenance.	10
Safety Precautions.	3	Figures.	11-13
Operating Limitations.	3	Tables.	14-15
Installation.	4-6	Assembly Drawings.	16
Lubrication.	7	Parts List.	17
Operation.	8	Basic Connection & Drive Shaft Information.	18
Troubleshooting.	9		

Do These Things To Get The Most From Your ROOTS™ blower

- Check shipment for damage. If found, file claim with carrier and notify Roots.
- Unpack shipment carefully, and check contents against Packing List. Notify Roots if a shortage appears.
- Store in a clean, dry location until ready for installation. Lift by methods discussed under INSTALLATION to avoid straining or distorting the equipment. Keep covers on all openings. Protect against weather and corrosion if outdoor storage is necessary.
- Read OPERATING LIMITATIONS and INSTALLATION sections in this manual and plan the complete installation.
- Provide for adequate safeguards against accidents to persons working on or near the equipment during both installation and operation. See SAFETY PRECAUTIONS.
- Install all equipment correctly. Foundation design must be adequate and piping carefully done. Use recommended accessories for operating protection.
- Make sure both driving and driven equipment is correctly lubricated before start-up. See LUBRICATION.**
- Read starting check points under OPERATION. Run equipment briefly to check for installation errors and make corrections. Follow with a trial run under normal operating conditions.
- In event of trouble during installation or operation, do not attempt repairs of Roots furnished equipment. Notify Roots, giving all nameplate information plus an outline of operating conditions and a description of the trouble. Unauthorized attempts at equipment repair may void Roots warranty.
- Units out of warranty may be repaired or adjusted by the owner. Good inspection and maintenance practices should reduce the need for repairs.

NOTE: Information in this manual is correct as of the date of publication. Roots reserves the right to make design or material changes without notice, and without obligation to make similar changes on equipment of prior manufacture.

For your nearest Roots Office, dial our Customer Service Hot Line toll free; 1 877 363 ROOT(S) (7668) or direct 832-590-2600.



Safety Precautions

It is important that all personnel observe safety precautions to minimize the chances of injury. Among many considerations, the following should be particularly noted:

- Blower casing and associated piping or accessories may become hot enough to cause major skin burns on contact.
- Internal and external rotating parts of the blower and driving equipment can produce serious physical injuries. Do not reach into any opening in the blower while it is operating, or while subject to accidental starting. Protect external moving parts with adequate guards.
- Disconnect power before doing any work, and avoid bypassing or rendering inoperative any safety or protective devices.
- If blower is operated with piping disconnected, place a strong coarse screen over the inlet and avoid standing in the discharge air stream. **CAUTION: Never cover the blower inlet with your hand or other part of body.**
- Stay clear of the blast from pressure relief valves and the suction area of vacuum relief valves.
- Use proper care and good procedures in handling, lifting, installing, operating and maintaining the equipment.
- Casing pressure must not exceed 25 PSI (1725 mbar) gauge. Do not pressurize vented cavities from an external source, nor restrict the vents without first consulting Roots.
- Do not use air blowers on explosive or hazardous gases.
- Other potential hazards to safety may also be associated with operation of this equipment. All personnel working in or passing through the area should be trained to exercise adequate general safety precautions.

Operating Limitations

A ROOTS blower or exhauster must be operated within certain approved limiting conditions to enable continued satisfactory performance. Warranty is contingent on such operation.

Maximum limits for pressure, temperature and speed are specified in TABLE 1 for various models & sizes of blowers & exhausters. These limits apply to all units of normal construction, when operated under standard atmospheric conditions. Be sure to arrange connections or taps for instruments, thermometers and pressure or vacuum gauges at or near the inlet and discharge connections of the unit. These, along with a tachometer, will enable periodic checks of operating conditions.

PRESSURE – The pressure rise, between inlet and discharge, must not exceed the figure listed for the specific unit frame size concerned. Also, in any system where the unit inlet is at a positive pressure above atmosphere a maximum case rating of 25 PSI gauge (1725 mbar) should not be exceeded without first consulting Roots. Never should the maximum allowable differential pressure be exceeded.

On vacuum service, with the discharge to atmospheric pressure, the inlet suction or vacuum must not be greater than values listed for the specific frame size.

TEMPERATURE – Blower & exhauster frame sizes are approved only for installations where the following temperature limitations can be maintained in service:

- Measured temperature rise must not exceed listed values when the inlet is at ambient temperature. Ambient is considered as the general temperature of the space around the unit. This is not outdoor temperature unless the unit is installed outdoors.
- If inlet temperature is higher than ambient, the listed allowable temperature rise values must be reduced by 2/3 of the difference between the actual measured inlet temperature and the ambient temperature.
- The average of the inlet and discharge temperature must not exceed 250°F. (121°C).
- The ambient temperature of the space the blower/motor is installed in should not be higher than 120°F (48.8°C).

SPEED – These blowers & exhausters may be operated at speeds up to the maximum listed for the various frame sizes. They may be direct coupled to suitable constant speed drivers if pressure/temperature conditions are also within limits. At low speeds, excessive temperature rise may be a limiting factor.

Special Note: The listed maximum allowable temperature rise for any particular blower & exhauster may occur well before its maximum pressure or vacuum rating is reached. This may occur at high altitude, low vacuum or at very low speed. The units' operating limit is always determined by the maximum rating reached first. It can be any one of the three: Pressure, Temperature or Speed.

Lubrication

For Units with Splash Lubrication on Both Ends

Bearings and oil seals are lubricated by the action of the timing gears or oil slingers which dip into the main oil sumps

causing oil to splash directly on gears and into bearings and seals. A drain port is provided below each bearing to prevent an excessive amount of oil in the bearings. Seals located inboard of the bearings in each headplate effectively retain oil within the sumps. Any small leakage that may occur should the seals wear passes into a cavity in each vented headplate and is drained downward.

Oil sumps on each end of the blower are filled by removing top vent plugs, Item (25), and filling until oil reaches the middle of the oil level sight gauge when the unit is not operating, Item (45 or 53), DO NOT FILL PAST THE MIDDLE OF THE SIGHT GLASS.

Initial filling of the sumps should be accomplished with the blower not operating, in order to obtain the correct oil level. Approximate oil quantities required for blowers of the various models and configurations are listed in Table 3. Use a good grade of industrial type non-detergent, rust inhibiting, anti-foaming oil and of correct viscosity per Table 2. ***ROOTS synthetic oil (Roots P/N 813-106-) is specified and recommended.** Roots does not recommend automotive type lubricants, as they are not formulated with the properties mentioned above.

The oil level may rise or fall on the gauge during operation, to an extent depending somewhat on oil temperature and blower speed.

Proper lubrication is usually the most important single consideration in obtaining maximum service life and satisfactory operation from the unit. Unless operating conditions are quite severe, a weekly check of oil level and necessary addition of lubricant should be sufficient. During the first week of operation, check the oil levels in the oil sumps about once a day, and watch for leaks. Replenish as necessary. Thereafter, an occasional check should be sufficient. It is recommended that the oil be changed after initial 100 hours of operation. Frequent oil changing is not necessary unless the blower is operated in a very dusty location.

Normal life expectancy of petroleum based oils is about 2000 hours with an oil temperature of about 180°F (82°C). As the oil temperature increases by increments of 15-18°F (8°C - 10°C), the life is reduced by half. Example: Oil temperatures of 210-216°F (99°C - 102°C) will produce life expectancy of 1/4 or 500 hours. Therefore, it is considered normal to have oil change periods of 500 hours with petroleum based oils.

Normal life expectancy of ROOTS™ Synthetic Oil is about 4000 to 8000 hours with an oil temperature of about 180°F (82°C). As the oil temperature increases by increments of 15-18°F (8°C - 10°C), the life is reduced by half. Example: Oil temperatures of 210-216°F (99°C - 102°C) will produce life expectancy of 1/4 or 1000 to 2000 hours.

NOTE: To estimate oil temperature, multiply the discharge temperature of the blower by 0.80. Example: if the discharge air temperature of the blower is 200° F, it is estimated that the oil temperature is 160° F.

*ROOTS™ Synthetic Oil & Grease is superior in performance to petroleum based products. It has high oxidation stability, excellent corrosion protection, extremely high film strength and low coefficient of friction. Typical oil change intervals are increased 2-3 times over petroleum based lubricants. Also, ROOTS™ Synthetic Oil is 100% compatible with petroleum based oils. Simply drain the oil in the blower and refill the reservoirs with ROOTS™ Synthetic Oil to maintain optimum performance of your ROOTS™ blower.

Operation

Before operating a blower under power for the first time, recheck the unit and the installation thoroughly to reduce the likelihood of avoidable troubles. Use the following procedure check list as a guide, but consider any other special conditions in the installation.

- Be certain that no bolts, tools, rags, or debris have been left in the blower air chamber or piping.
- If an outdoor intake without filter is used, be sure the opening is located so it cannot pick up dirt and is protected by a strong screen or grille. Use of the temporary protective screen as described under INSTALLATION is strongly recommended.
- Recheck blower leveling, drive alignment and tightness of all mounting bolts if installation is not recent. If belt drive is used, adjust belt tension correctly.
- Turn drive shaft by hand to make sure impellers still rotate without bumping or rubbing at any point.
- Ensure oil levels in the main oil sumps are correct.
- Check lubrication of driver. If it is an electric motor, be sure that power is available and that electrical overload devices are installed and workable.
- Open the manual unloading valve in the discharge air line. If a valve is in the inlet piping, be sure it is open.
- Bump blower a few revolutions with driver to check that direction of rotation agrees with arrow near blower shaft, and that both coast freely to a stop.

After the preceding points are cleared, blower is ready for trial operation under "no-load" conditions. The following procedure is suggested to cover this initial operation test period.

- a. Start blower, let it accelerate to full speed, then shut off. Listen for knocking sounds, both with power on and as speed slows down.
- b. After blower comes to a complete stop, repeat above, but let blower run 2 or 3 minutes. Check for noises, such as knocking sounds.
- c. After blower comes to a complete stop, operate blower for about 10 minutes unloaded. Check oil levels. Observe cylinder and headplate surfaces for development of hot spots such as burned paint, indicating impeller rubs. Be aware of any noticeable increase in vibration.

Assuming that all trials have been satisfactory, or that necessary corrections have been made, the blower should now have a final check run of at least one hour under normal operating conditions. After blower is restarted, gradually

close the discharge unloading valve to apply working pressure. At this point it is recommended that a pressure gauge or manometer be connected into the discharge line if not already provided, and that thermometers be in both inlet and discharge lines. Readings from these instruments will show whether pressure or temperature ratings of the blower are being exceeded.

During the final run, check operating conditions frequently and observe the oil levels at reasonable intervals. If excessive noise or local heating develops, shut down immediately and determine the cause. If either pressure rise or temperature rise across the blower exceeds the limit specified in this manual, shut down and investigate conditions in the piping system. Refer to the TROUBLESHOOTING CHECKLIST for suggestions on various problems that may appear.

The blower should now be ready for continuous duty operation at full load. During the first few days make periodic checks to determine whether all conditions remain steady, or at least acceptable. This may be particularly important if the blower is supplying air to a process system where conditions can vary. At the first opportunity, stop the blower and clean the temporary inlet protective screen. If no appreciable amount of debris has collected, the screen may be removed. See comments under INSTALLATION. At this same time, verify leveling, coupling alignment or belt tension, and mounting bolt tightness.

Should operating experience prove that blower capacity is a little too high for the actual air requirements, a small excess may be blown off continuously through the manual unloading or vent valve. Never rely on the pressure relief valve as an automatic vent. Such use may cause the discharge pressure to become excessive, and can also result in failure of the valve itself. If blower capacity appears to be too low, refer to the TROUBLESHOOTING CHECKLIST.

Vibration Assessment Criteria

With measurements taken at the bearing locations on the housings, see chart below for an appropriate assessment guide for rotary lobe blowers rigidly mounted on stiff foundations.

In general, blower vibration levels should be monitored on a regular basis and the vibration trend observed for progressive or sudden change in level. If such a change occurs, the cause should be determined through spectral analysis.

As shown on the chart below, the level of all pass vibration will determine the need to measure discrete frequency vibration levels and the action required.

All Pass Vibration (in/sec)	Discrete Frequency Vibration (in/sec)	Action
0.45 or less	N/R	Acceptable
Greater than 0.45 but 1.0 or less	0.45 or less @ any frequency	Acceptable
	Greater than 0.45 @ any frequency	Investigate
Greater than 1.0	Less than 1.0	Investigate
	Greater than 1.0	Investigate

Troubleshooting Checklist

Trouble	Item	Possible Cause	Remedy
No flow	1	Speed too low	Check by tachometer and compare with published performance
	2	Wrong rotation	Compare actual rotation with Figure 1 Change driver if wrong
	3	Obstruction in piping	Check piping, valves, silencer to assure open flow path
Low capacity	4	Speed too low	See item 1, If belt drive, check for slippage and readjust tension
	5	Excessive pressure rise	Check inlet vacuum and discharge pressure and compare with Published performance
	6	Obstruction in piping	See item 3
	7	Excessive slip	Check inside of casing for worn or eroded surfaces causing excessive clearances
Excessive power	8	Speed too high	Check speed and compare with published performance
	9	Excessive pressure rise	See Item 5
	10	Impeller rubbing	Inspect outside of cylinder for high temperature areas, then check for impeller contact at these points. Correct blower mounting, drive alignment
	11	Scale, sludge, rust or product build up	Clean blower appropriately
Damage to bearings or gears	12	Inadequate lubrication	Check oil sump levels in gear and drive end headplates
	13	Excessive lubrication	Check oil levels. If correct, drain and refill with clean oil of recommended grade
	14	Excessive pressure rise	See Item 5
	15	Coupling misalignment	Check carefully. Realign if questionable
	16	Excessive belt tension	Readjust for correct tension
Vibration	17	Misalignment	See Item 15
	18	Impellers rubbing	See Item 10
	19	Worn bearings/gears	Check gear backlash and condition of bearings, and replace as indicated
	20	Unbalanced or rubbing impeller	Scale or process material may build up on casing and impellers, or inside impellers. Remove build-up to restore original clearances and impeller balance
	21	Driver or blower loose	Tighten mounting bolts securely
	22	Piping resonances	Determine whether standing wave pressure pulsations are present in the piping
	23	Scale/sludge build-ups	Clean out interior of impeller lobes to restore dynamic balance
Driver stops, or will not start	24	Casing strain	Re-work piping alignment to remove excess strain
	25	Impeller stuck	Check for excessive hot spot on headplate or cylinder. See item 10. Look for defective shaft bearing and/or gear teeth
	26	Scale, sludge, rust or product build-up	Clean blower appropriately
Excessive breather Blow-by or excessive oil leakage to vent area Excessive oil leakage in vent area	27	Broken seal	Replace seals
	28	Defective O-ring	Replace seals and O-ring
	29	Defective/plugged breather	Replace breather and monitor oil leakage
	30	Oil level too high	Check sump levels in gear and drive headplates.
	31	Oil type or viscosity incorrect	Check oil to insure it meets recommendations. Drain then fill with clean oil of recommended grade.
	32	Blower running hot	Check blower operating conditions to ensure they are within the operating limitations defined in this manual.

Inspection & Maintenance: Universal RAI® series blowers

A good program of consistent inspection and maintenance is the most reliable method of minimizing repairs to a blower. A simple record of services and dates will help keep this work on a regular schedule. Basic service needs are:

- Lubrication
- Checking for hot spots
- Checking for increases or changes in vibration and noise
- Recording of operating pressures and temperatures

Above all, a blower must be operated within its specified rating limits, to obtain satisfactory service life.

A newly installed blower should be checked often during the first month of full-time operation. Attention there after may be less frequent assuming satisfactory performance.

Lubrication is normally the most important consideration and weekly checks of lubricant levels in the gearbox and bearing reservoirs should be customary. Complete oil change schedules are discussed under **LUBRICATION**.

Driver lubrication practices should be in accordance with the manufacturer's instructions. If direct connected to the blower through a lubricated type coupling, the coupling should be checked and greased each time blower oil is changed. This will help reduce wear and prevent unnecessary vibration. In a belted drive system, check belt tension periodically and inspect for frayed or cracked belts.

In a new, and properly installed, unit there is no contact between the two impellers, or between the impellers and cylinder or headplates. Wear is confined to the bearings (which support and locate the shafts) the oil seals, and the timing gears. All are lubricated and wear should be minimal if clean oil of the correct grade is always used. Seals are subject to deterioration as well as wear, and may require replacement at varying periods.

Shaft bearings are designed for optimum life under average conditions with proper lubrication and are critical to the service life of the blower. Gradual bearing wear may allow a shaft position to change slightly, until rubbing develops between impeller and casing. This will cause spot heating, which can be detected by observing these surfaces. Sudden bearing failure is usually more serious. Since the shaft and impeller are no longer supported and properly located, extensive general damage to the blower casing and gears is likely to occur.

Oil seals should be considered expendable items, to be replaced whenever drainage from the headplate vent cavity becomes excessive or when the blower is disassembled for

any reason. Some oil seal leakage may occur since an oil film under the lip is required for proper operation. Periodically leaked oil should be wiped off from surfaces. Minor seal leakage should not be considered as indicating seal replacement.

Timing gear wear, when correct lubrication is maintained, should be negligible. Gear teeth are cut to provide the correct amount of backlash, and gears correctly mounted on the shafts will accommodate a normal amount of tooth wear without permitting contact between lobes of the two impellers. However, too high an oil level will cause churning and excessive heating. This is indicated by unusually high temperature at the bottom of the gear housing. Consequent heating of the gears will result in loss of tooth-clearance, backlash and rapid wear of the gear teeth usually will develop. Continuation of this tooth wear will eventually produce impeller contacts (knocking), and from this point serious damage will be unavoidable if blower operation is continued. A similar situation can be produced suddenly by gear tooth fracture, which is usually brought on by sustained overloading or momentary shock loads.

Problems may also develop from causes other than internal parts failure. Operating clearances within a blower are only a few thousandths of an inch. This makes it possible for impeller interference or casing rubs to result from shifts in the blower mounting, or from changes in piping support. If this type of trouble is experienced, and the blower is found to be clean, try removing mounting strains. Loosen blower mounting bolts and reset the leveling and drive alignment. Then tighten mounting again, and make sure that all piping meets blower connections accurately and squarely. Foreign materials in the blower will also cause trouble, which can only be cured by disconnecting the piping and thoroughly cleaning the blower interior.

A wide range of causes & solutions for operating troubles are covered in the **TROUBLE SHOOTING CHECKLIST**. The remedies suggested should be performed by qualified mechanics with a good background. Major repairs generally are to be considered beyond the scope of maintenance, and should be referred to an authorized Roots distributor.

Warranty failures should not be repaired at all, unless specific approval has been obtained through Roots before starting work. Unauthorized disassembly within the warranty period may void the warranty.

Figure 2 - Allowable Overhung Loads for V-Belt Drives Universal RAI®/URAI®-DSL Units

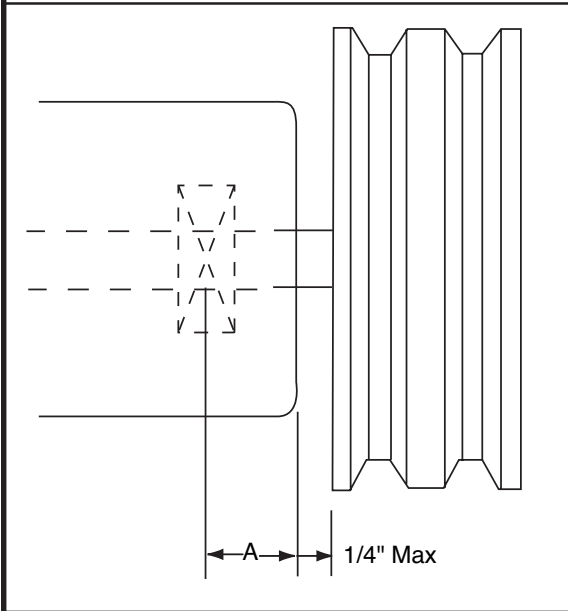

$$\text{Belt Pull lbs} = \frac{252100 \cdot \text{Motor HP}}{\text{Blower RPM} \cdot \text{Sheave Diameter}}$$

$$\text{Shaft Load (lb.in)} = \text{Belt Pull} \cdot \left(A + \frac{1}{4}'' + \frac{\text{Sheave Width}}{2} \right)$$

Frame Size	Dimension "A"	Max Allowable Shaft Load (lb-in)	Min Sheave Diameter
47	1.02	650	5.00

NOTE:

Arc of sheave belt contact on the smaller sheave not to be less than 170°

Driver to be installed on the inlet side for vertical units, and on the drive shaft side for horizontal units.

Roots recommends the use of two or more 3V, 5V or 8V matched set or banded belts and sheaves.

Specified Lubricants

ROOTS Synthetic Oil: ISO-VG-320 Grade

Part Number

Quart 13106004

Gallon 13106005

Case (12 qts) 13106007

ROOTS Synthetic Oil: ISO-VG-220 Grade

Part Number

Quart 13106001

Gallon 13106002

Case (12 qts) 13106008

ROOTS Synthetic Oil: ISO-VG-150 Grade

Part Number

Quart 13106020

Gallon 13106021

Case (12 qts) 13106023

5 Gallon Pail 13106022

55 Gallon Drum 13106025

Drive End Breather Orientation for URA-DSL blowers with Oil Lube

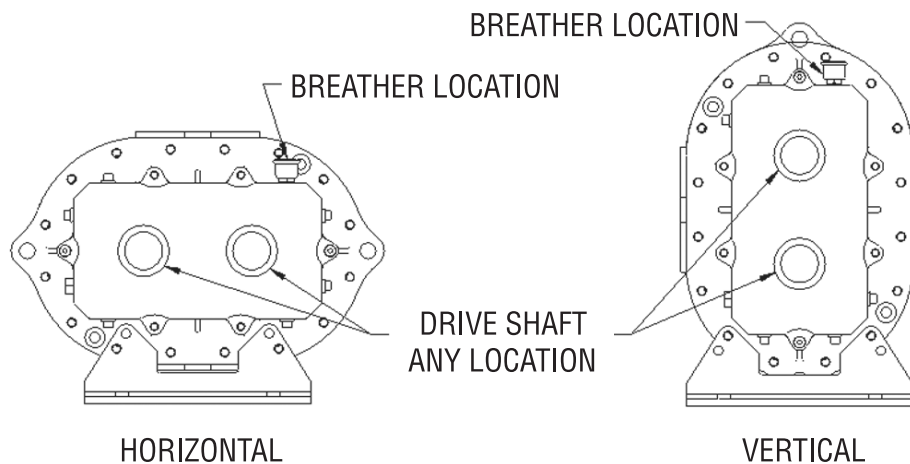

URAI DSL BREATHER ORIENTATION

**Table 1 - URAI, URAI-DSL Blowers,
Maximum Allowable Operating Conditions**

Frame Size	Gear Diameter (Inch)	Speed RPM	Temp. Rise Deg F (Deg C)	Delta Pressure PSI (mbar)	Inlet Vacuum INHG (mbar)
47	4	3,600	225 (125)	7 (483)	15 (500)

Table 2 - Recommended Oil Grades

Ambient Temperature °F (°C)	ISO Viscosity No.
Above 90° (32°)	320
32° to 90° (0° to 32°)	220
0° to 32° (-18° to 0°)	150
Below 0° (-18°)	100

Ambient temperature is defined as the temperature of the space in which the blower and drive are located.

Table 3 - Approximate Oil Sump Capacities

These capacities are provided to assist in stocking the correct amount of oil. Exact sump capacities may differ slightly. See "Lubrication" section for proper filling instructions.

URAI-DSL Splash Lubricated Blowers

Frame Size	Gear End Capacity Fl. Oz (Liters)	Drive End Capacity Fl. Oz. (Liters)
47	22.8 (.67)	10.8 (.32)

Basic Connection & Drive Shaft Information

URAI DSL AIR BLOWERS (with Dual Splash Lubrication DSL)

BOM#	FRAME SIZE	INLET/DISCHARGE CONN.	SHAFT DIAMETER	BARE WEIGHT
T30354020	47	3" NPT	.0875"	132

Universal RAI air blowers include detachable mounting feet which permit vertical or horizontal installation. The units are center timed for rotation in either direction. The bearings on the URAI are grease lubricated on the drive end and splash lubricated on the gear end. The URAI-DSL is splash lubricated on BOTH ends.

PAGE LEFT BLANK

V750 ELECTRICAL SCHEMATIC GX660

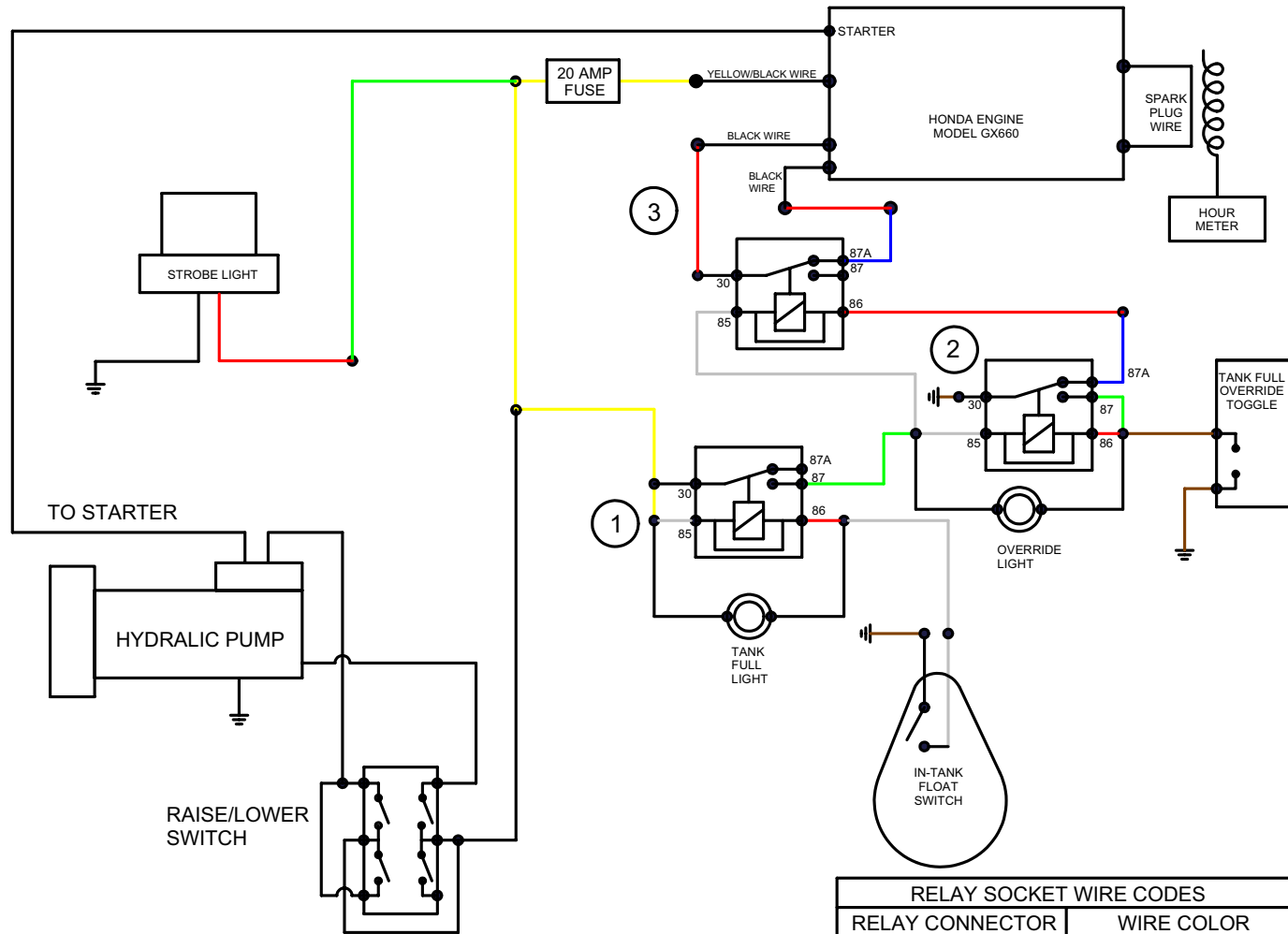

RELAY SOCKET WIRE CODES	
RELAY CONNECTOR	WIRE COLOR
30	BLACK
85	WHITE
86	RED
87A	BLUE
87	GREEN

PAGE LEFT BLANK

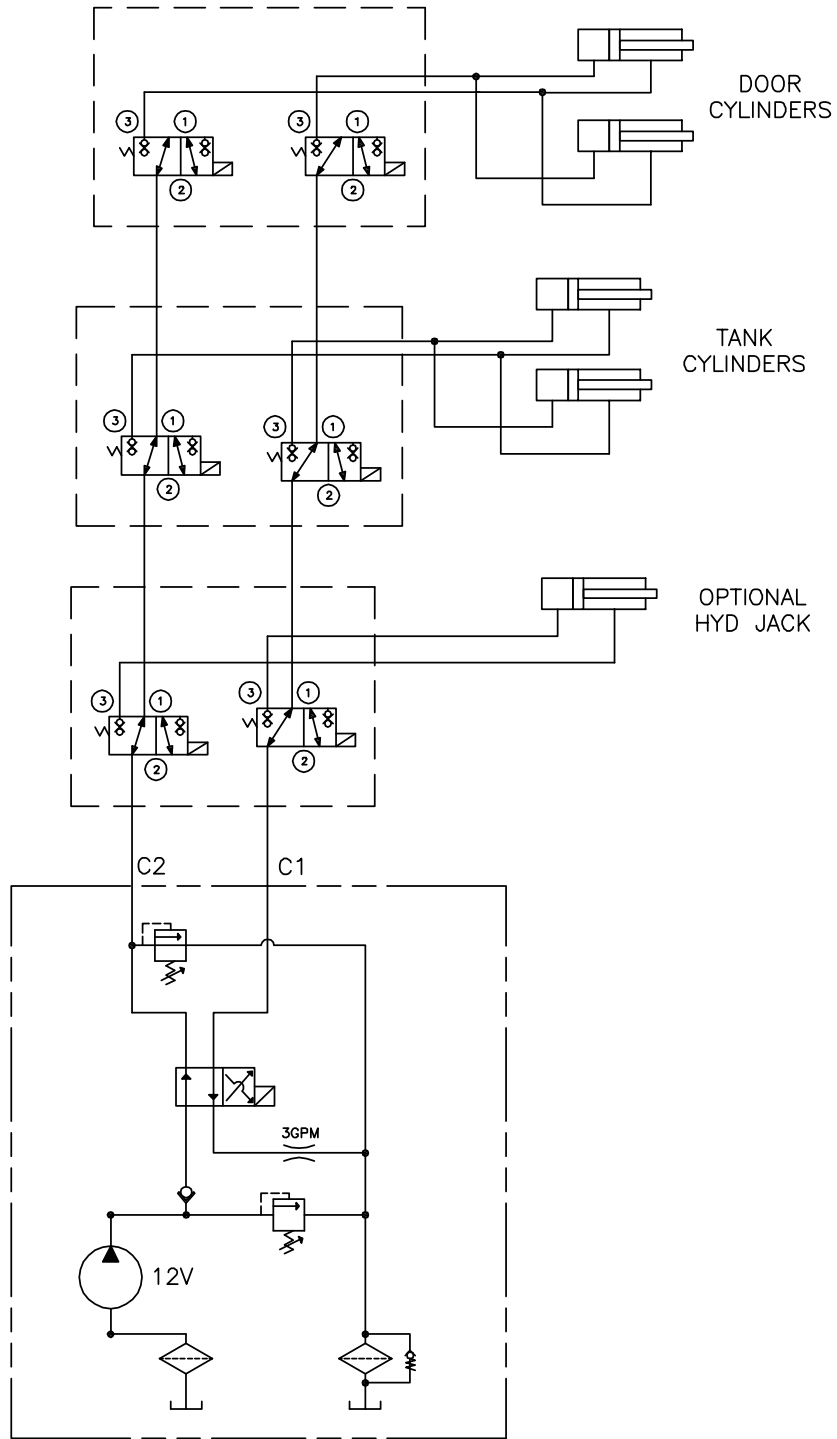

BASE HYDRAULIC MANIFOLD

VACUUM SYSTEM
 W/O BOOM
 12V HYDRAULIC SCHEMATIC

WARRANTY RETURN GOODS POLICY

LIMITED WARRANTY

The Manufacturer warrants its products to be free from defects in material and workmanship for a period of twelve months from the date of shipment from the factory. The Manufacturer shall not be responsible for any damage resulting to or caused by its products by reason of installation, improper storage, unauthorized service, alteration of the products, neglect or abuse, or use of the product in a manner inconsistent with its design. The warranty does not extend to any component parts not manufactured by Manufacturer; however, Manufacturer's warranty herein shall not limit any warranties made by manufacturers of component parts which extend to Buyer.

Claims for defects in material and workmanship shall be made in writing to Manufacturer within ten days of discovery of defect. Manufacturer may either send a service representative or have the product returned to its factory at Buyer's expense for inspection. Upon notification of defect, Manufacturer will issue a return goods authorization number to Buyer. The return goods authorization number must accompany the product returned. If judged by the Manufacturer to be defective in material or workmanship, the product will be replaced or repaired at the option of the Manufacturer, free from all charges except authorized transportation. Buyer shall be responsible for all maintenance services consisting of lubrication and cleaning of equipment, replacing expandable parts making minor adjustments, and performing operating checks, all in accordance with procedures outlined in Manufacturer's maintenance literature.

THE FOREGOING WARRANTY IS IN LIEU OF ALL OTHER WARRANTIES AND NO REPRESENTATIONS, GUARANTEES, OR WARRANTIES, EXPRESS OR IMPLIED, (INCLUDING BUT NOT LIMITED TO A WARRANTY OF MERCHANTABILITY OR FITNESS FOR A PARTICULAR PURPOSE), ARE MADE BY THE MANUFACTURER IN CONNECTION WITH THE MANUFACTURE OR SALE OF ITS PRODUCTS. NO EMPLOYEE, DISTRIBUTOR OR REPRESENTATIVE IS AUTHORIZED TO CHANGE THIS WARRANTY ON BEHALF OF MANUFACTURER. THE REMEDIES OF BUYER SET FORTH HEREIN ARE EXCLUSIVE AND ARE IN LIEU OF ALL OTHER REMEDIES. THE LIABILITY OF MANUFACTURER WHETHER IN CONTRACT, TORT, UNDER ANY WARRANTY, OR OTHERWISE SHALL NOT EXTEND BEYOND ITS OBLIGATION TO REPAIR OR REPLACE, AT ITS OPTION ANY PRODUCT OR PART FOUND BY MANUFACTURER TO BE DEFECTIVE IN MATERIAL OR WORKMANSHIP. MANUFACTURER SHALL NOT BE LIABLE FOR COST OF INSTALLATION AND/OR REMOVAL OR BE RESPONSIBLE FOR DIRECT, INDIRECT, SPECIAL OR CONSEQUENTIAL DAMAGES OF ANY NATURE.

GENERAL RETURNS OF MERCHANDISE

1. All returns must be pre-authorized
 - A. Please call our parts department for an RGA number
 - B. Please include RGA number on the outside of box
 - C. Include any required paper work or special instructions
 - D. Items returned without an RGA number will not be accepted
2. All returns are subject to a 20% restock charge.
3. Special items are non-returnable
 - A. Non-stock parts
 - B. Custom parts
 - C. If you are unsure about a parts status when ordering, ask your McLaughlin representative if the item fits on of the above conditions.
4. Items must be returned within thirty days of original order date.
5. Items not returned within 30 days from the date of RGA is issued will not be accepted.
6. The item(s) must be in new condition. Used item(s) are not returnable.

