



**McLAUGHLIN®**

2006 Perimeter Road. Greenville, SC 29605  
Toll Free: 800/435-9340 - Phone: 864/277-5870  
Fax: 864/235-9661 - Website address: [www.mightymole.com](http://www.mightymole.com)  
Email address: [mmole@mightymole.com](mailto:mmole@mightymole.com)

**Parts Manual**  
**Vermeer/ McLaughlin V800HD Vacuum Machine**  
**HD Reversible Flow Option**  
**SERIAL # 8DHD101606786 - Present**

© 2007 by McLaughlin Group, Inc.

52507

All rights reserved. No part of this manual may be reproduced in any form, or by any means without prior written permission of McLaughlin Group, Inc.

# Tank and Door Assembly

# V800HD

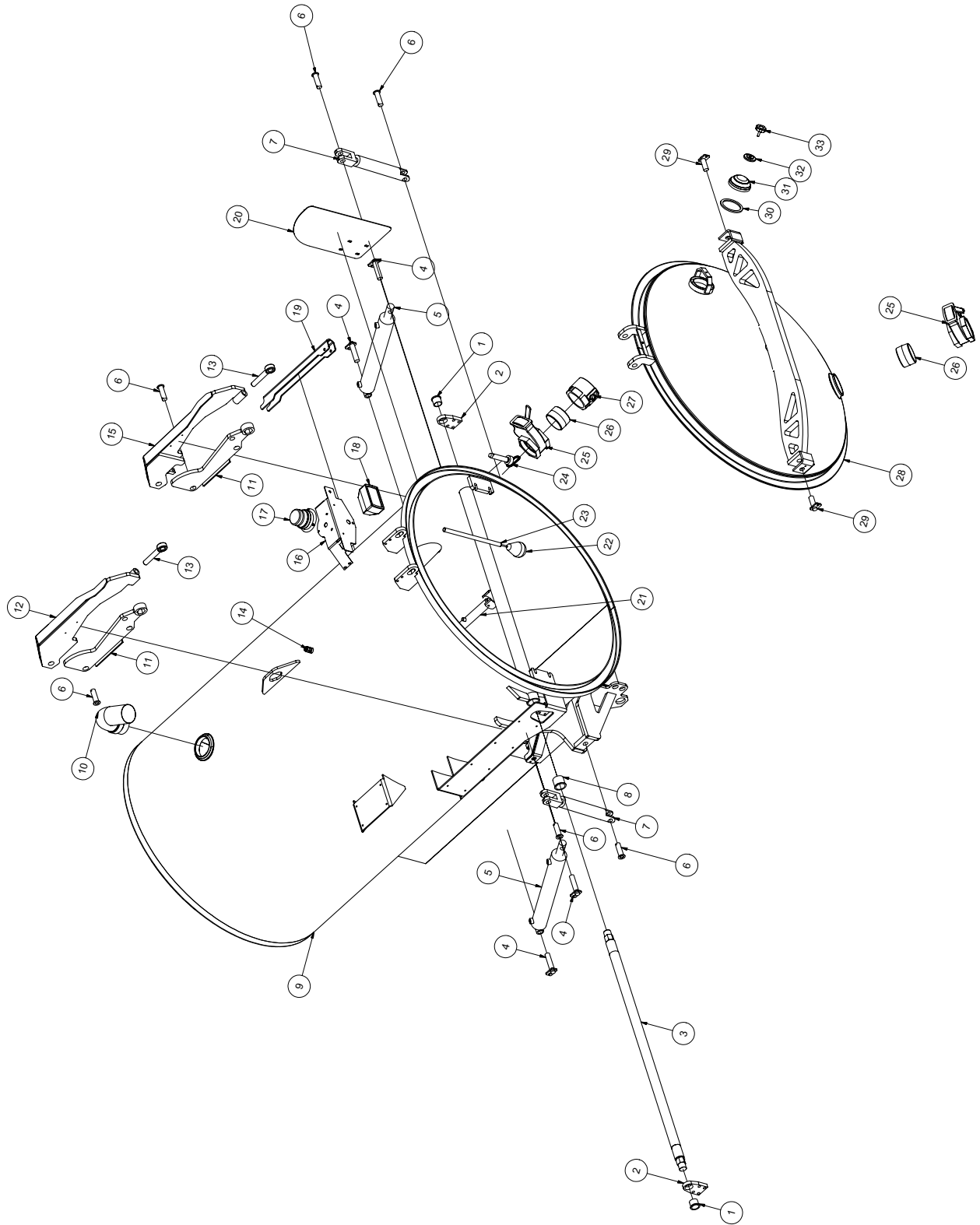

VACASSY014

# Tank and Door Assembly

# V800HD

ITEM	QTY	NUMBER	DESCRIPTION	ITEM	QTY	NUMBER	DESCRIPTION
1	2	8041610	BUSHING BRONZE FLANGED 1 1/2"	21	1	8041721	TANK ROD -800 HLD
2	2	8041621	OUTER BEARING PLATE	1	1	8030446	O-RING #328 BUNA
3	1	8041663	LINKAGE CROSS TUBE	4	4	U000880	SCREW, HC 1/2-13 X 2.00
4	4	8030128	CYLINDER PIN WELDMENT	4	4	U100120	NUT, HEX 1/2-13
5	2	8030359	SPOIL TANK CYLINDER	8	8	U200100	WASHER, FLAT 1/2"
	1	8041456	HOSE ASSY VAC 6-70 ST-90	3	3	U010055	SCREW, HSH 5/16-18 X 1.50
	1	8041457	HOSE ASSY VAC 6-90 ST-90	3	3	8030369	TANK CLEANOUT NOZZLES
	1	8041458	HOSE ASSY VAC 6-86 ST-ST	22	1	8030531	HIGH LEVEL FLOAT SWITCH
	1	8041459	HOSE ASSY VAC 6-105 ST-ST	23	1	8041471	FLOAT SWITCH TUBE V800
	4	T401270	ELBOW, 90 8MB-6MJ	1	1	8041291	BUSHING, RUBBER
6	6	8042489	HYD DOOR - PIN WELDMENT 1"DIA X 3"	24	1	8041626	1" x 4 1/2" HITCH PIN
7	2	8041327	HYD CYLINDER - 8" STROKE	25	2	8030916	4" GATE VALVE
8	2	8041602	BUSHING BRONZE FLANGED 2"	26	2	8030431	4" CLOSE NIPPLE
9	1	8041643	800 TANK - WELDMENT (54")	27	1	8030846	4" FEMALE COUPLER
	1	8030038	TANK PIVOT ROD	28	1	8041580	800 HYD LOCK DOOR
	2	8030363	2" SPIRAL SNAP RING	1	1	8040058	DOOR HINGE ROD
10	1	8040786	EXHAUST ELBOW 4"	2	2	U210200	DOOR HINGE WASHER
11	2	8041604	SHORT LINKAGE WELDMENT	2	2	U500020	1" SNAP RING
12	1	8041375	DOOR HYD LONG LINKAGE	1	1	8041767	DOOR SEAL
13	2	8041630	ROD END WITH BRONZE BUSHING	29	2	8042171	DOOR CAPTURE PIN
14	1	X000113	STRAIN RELIEF, 1/2"	30	1	8032007	GASKET, 4" COUPLER
15	1	8041369	DOOR HYD LONG LINKAGE	31	1	8031048	SIGHT GLASS
16	1	8041753	STROBE LIGHT BRACKET	32	1	8031047	SIGHT GLASS PLATE
	4	U000880	SCREW, HC 1/2-13 X 2.00	33	1	8031046	SIGHT GLASS HAND WHEEL
	4	U200100	WASHER, FLAT 1/2"	*	1	8041461	CABLE VAC SO4-216
	4	U210111	WASHER, LOCK 1/2"	*	1	8041354	LIGHT BRACKET
	4	U100120	NUT, HEX 1/2-13	*	1	8041839	DOOR SEAL GLUE
17	1	8030347	STROBE LIGHT				
	3	U010006	SCREW, PHILLIPS #10-24 X 1"				
	3	U210005	WASHER, LOCK #10				
	3	U100010	NUT, HEX #10-24				
18	1	8031242	WORK LIGHT				
19	1	8041212	TANK SAFETY BRACE				
	1	8041213	CLIP, SAFETY				
20	1	8041635	HYD ARM GUARD				

VACASSY014

# Power Pack Assembly

# V800HD

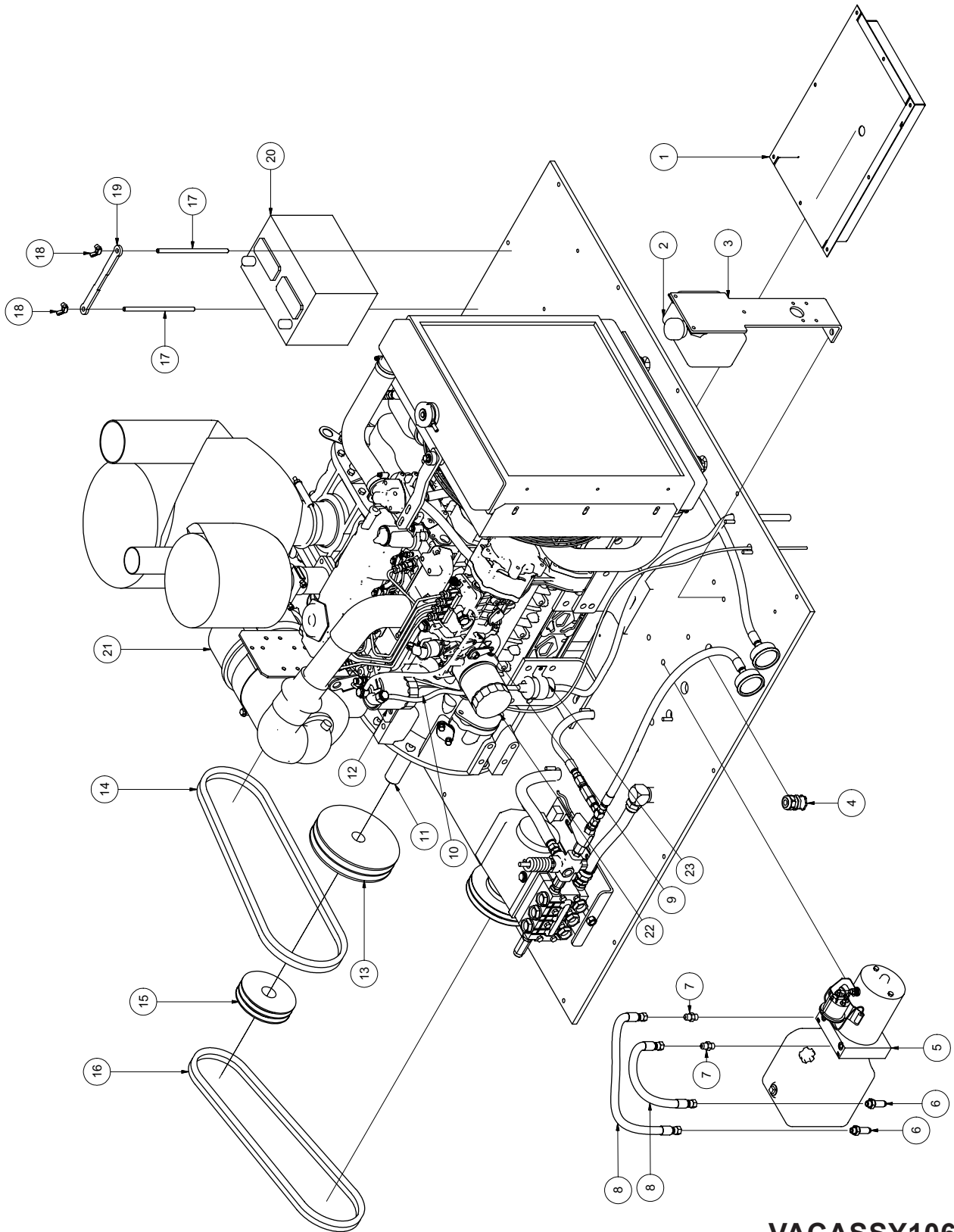

VACASSY106

# Power Pack Assembly

# V800HD

ITEM	QTY	NUMBER	DESCRIPTION	
1	1	8040694	DRIP PAN 73HP	
	8	U000040	SCREW, HC 1/4 - 20 X .750	
	8	U210020	WASHER, LOCK 1/4"	
	8	U200020	WASHER, FLAT 1/4"	
2	1	8040645	TANK, OVERFLOW COOLANT	
	3	U000040	SCREW, HC 1/4"-20 X 3/4"	
	6	U200020	WASHER, FLAT 1/4"	
	3	U210020	WASHER, LOCK 1/4"	
	3	U100020	NUT, HEX 1/4"-20	
3	1	8040577	WATER REGULATOR/OVERFLOW BRACKET	
	2	U000817	SCREW, HC 1/2"-13 X 1"	
	2	U210100	WASHER, LOCK 1/2"	
	2	U200100	WASHER, FLAT 1/2"	
4	1	X000112	CONNECTOR, PANEL 3/4 MNPT-3/4FNPT	
	1	X000109	STRAIN RELIEF, 3/4"	
	1	X000108	3/4" COUPLING NUT	
5	1	8041601	HYDRAULIC POWER PACK, 12V (KTI)	
	2	U000420	SCREW, HC 3/8"-16 X 1"	
	2	U210060	WASHER, LOCK 3/8"	
	2	U200600	WASHER, FLAT 3/8"	
6	2	T400391	BULKHEAD 6MP 6MP	
7	2	T400037	UNION 6MB-6MJ	
8	2	8040973	HOSE ASSY VAC 6-20 ST-90	
9	1	8041473	HOSE FUEL 5/16-18	
	2	8041472	HOSE FUEL 5/16-72	
	6	U800015	CLAMP, HOSE 04 - 5/8"	
10	1	8041474	HOSE FUEL 5/16-14	
	2	U800015	CLAMP, HOSE 04 - 5/8"	
11	1	8030908	KUBOTA V3300	
	1	8030908-1	MUFFLER	
	4	U000820	SCREW, HC 1/2"-13 X 1 1/4"	
	4	U210100	WASHER, LOCK 1/2"	
	4	U200100	WASHER, FLAT 1/2"	
12	1	8041053	KUBOTA FUEL FILTER	
13	1	8040482	SHEAVE 8.35 DIA 2 GROOVE	
	1	8040483	BUSHING 1 7/16" SK	
	1	U410125	KEY 3/8" X 3/8" X 2"	
14	2	8041081	BELT BX56	
15	1	8040480	SHEAVE 4.15 DIA 2 GROOVE	
	1	8040481	BUSHING 1 7/16" SH	
	1	U410125	KEY 3/8" X 3/8" X 2"	
16	2	8041082	BELT AX48	
17	2	8040684	ROD, BATTERY HOLD DOWN	
18	2	U130040	NUT, WING 3/8"-16	
19	1	8050016	BATTERY HOLD DOWN	
20	1	X400020	MT-34R 12V BATTERY	
	1	X300110	CABLE BATTERY VAC #711431 14"	
	1	X300001	CABLE BATTERY VAC #714134 41 1/2"	
21	1	8041054	KUBOTA AIR FILTER ELEMENT (PRIMARY)	
	1	8041055	KUBOTA AIR FILTER ELEMENT (SECONDARY)	
22	1	8032002	KUBOTA OIL FILTER	
23	1	8041056	PUMP, ELECTRIC FUEL	
	*	4	8030904	ISOLATOR
	4	U001320	SCREW, HC 5/8-11 X 4	
	4	8030851	WASHER, SNUBBING	
	4	U210140	WASHER, LOCK 5/8	
	4	U100180	NUT, HEX 5/8-11	
	8	U000420	SCREW, HC 3/8-16 X 1	
	16	U200060	WASHER, FLAT 3/8	
	8	U210060	WASHER, LOCK 3/8	
	8	U100060	NUT, HEX 3/8-16	

\* NOT SHOWN

**VACASSY106**

# Water Pump Assembly

## V800HD

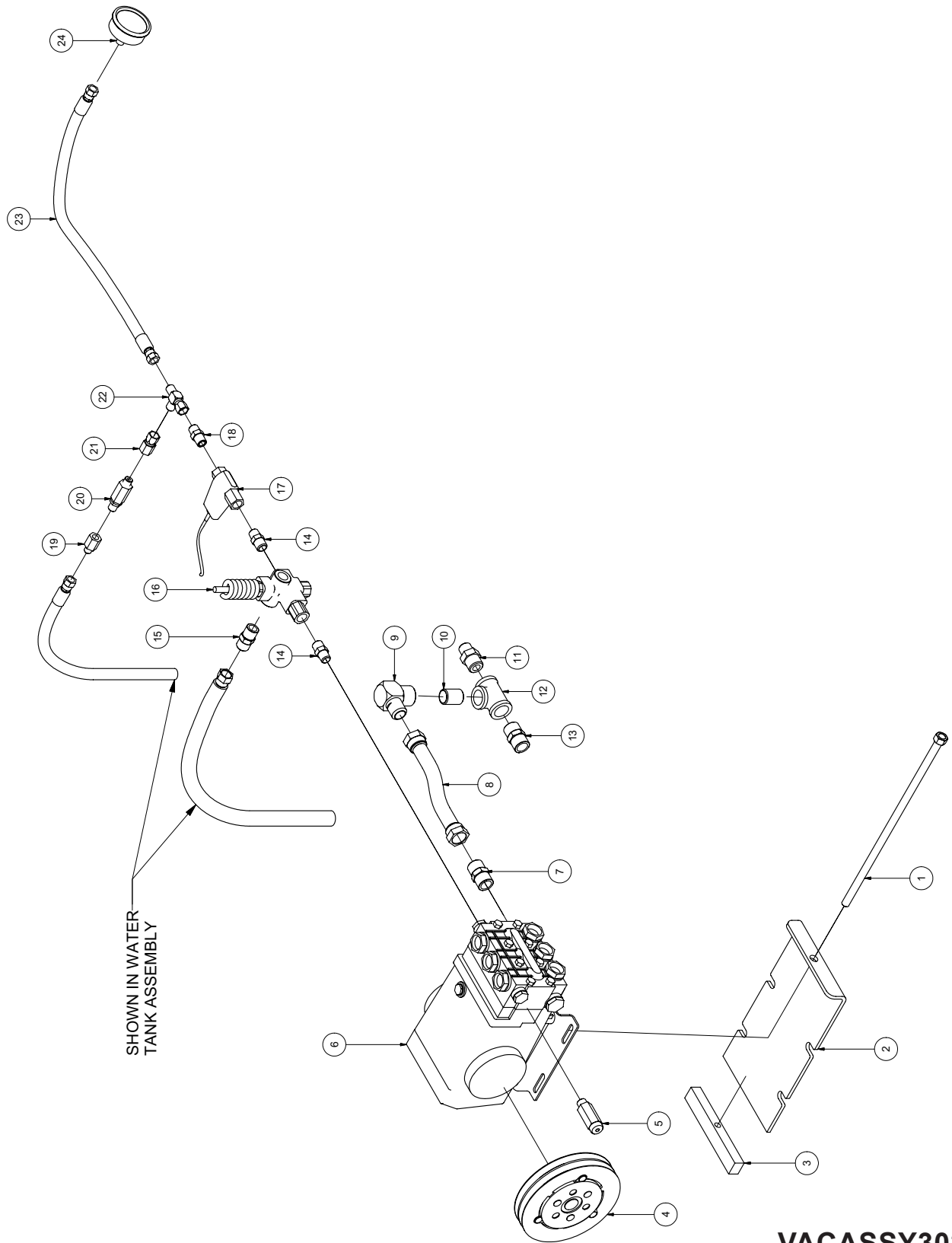

VACASSY302

# Water Pump Assembly

## V800HD

ITEM	QTY	NUMBER	DESCRIPTION
1	1	8040751	WATER PUMP TENSIONER ROD
2	1	8040892	WATER PUMP TENSIONER PLATE
3	1	8040893	WATER PUMP TENSIONER BLOCK
4	1	8030961	WATER PUMP CLUTCH
	1	U410094	KEY 5/16" X 5/16" X 1 3/8"
5	1	8030340	SAFETY RELIEF VALVE 6GPM
6	1	8031279	WATER PUMP
	4	U000420	SCREW, HC 3/8"-16 X 1"
	4	U210060	WASHER, LOCK 3/8"
	4	U200600	WASHER, FLAT 3/8"
7	1	T400070	UNION, 8MP 12MJ
8	1	8040972	HOSE VAC PUSH 12-8 1/2
	2	8030525	FITTING, HOSE #12FJ PUSH LOCK
9	1	T401180	ELBOW, 12MP 12MJ
10	1	T421020	NIPPLE, PIPE 12MP 12MP
11	1	T404030	UNION, 12MP 8MP
12	1	T402160	TEE 12FP 12FP 12FP
13	1	T400100	UNION, 12MP 12MJ
14	2	T400805	UNION, 8MP 6MP
15	1	T400040	UNION, 8MP 8MJ
16	1	8030341	UNLOADER VALVE
17	1	8031267	FLOW SWITCH
18	1	T400803	UNION, 6MP 6MP
19	1	8031126	UNION, 4FP 6MJ
20	1	8030923	HIGH PRESSURE WATER FILTER
21	1	8031125	UNION, 6FJ 4FP
22	1	T402153	TEE, 6MJ 6MJ 6FJ
23	1	8040971	HOSE ASSY VAC 4-19 ST-ST 6FJ
24	1	8030372	WATER PRESSURE GAUGE 1/4NPT

VACASSY302

# Enclosure Assembly

## V800HD

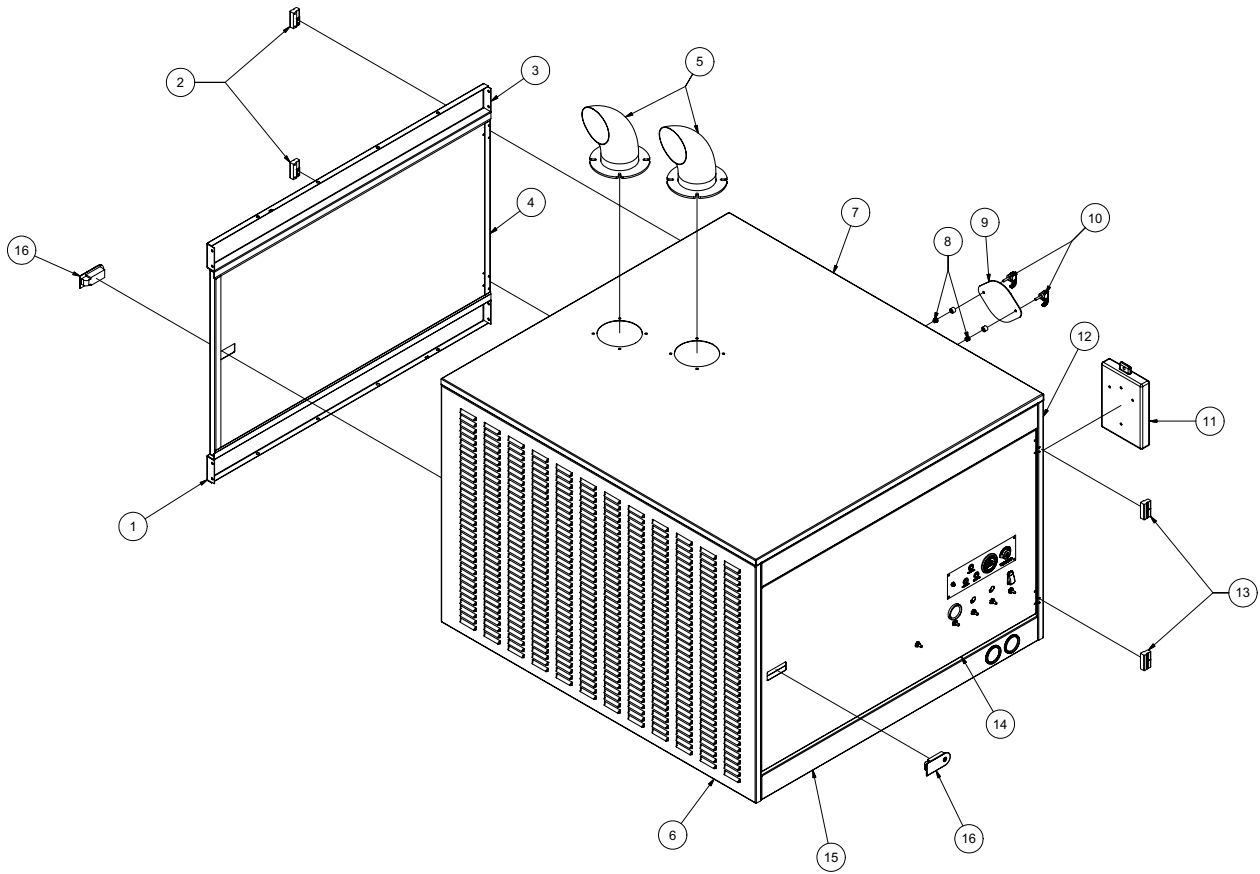

## VACASSY406

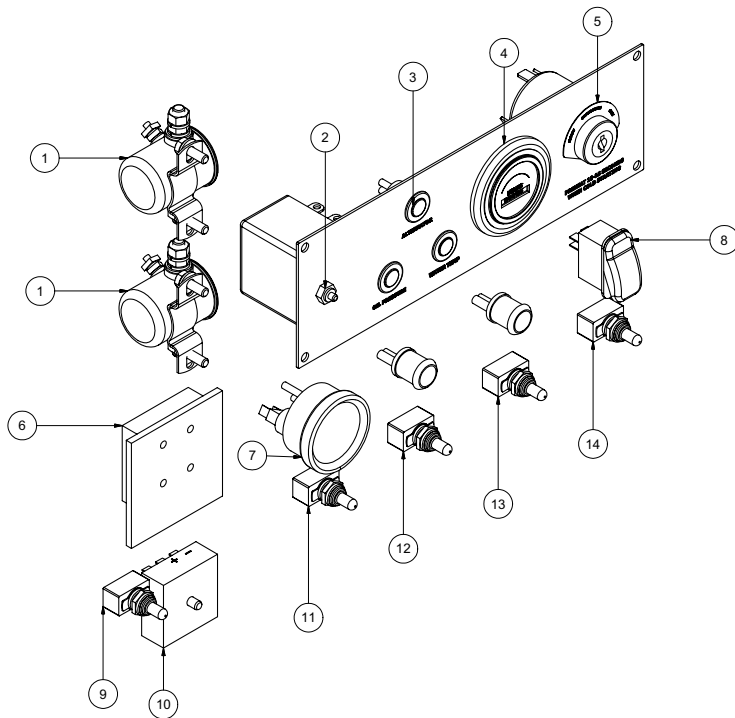

## VACASSY501



# Enclosure Assembly

## V800HD

ITEM	QTY	NUMBER	DESCRIPTION
1	1	8041014	SIDE PANEL
2	2	8040589	OFFSET HINGE TYPE A
	8	U030525	SCREW, PAN HD #10-32X1/2
3	2	8040692	UPPER SIDE PANEL
4	1	8040700	DOOR
5	2	8041195	EXHAUST WELDMENT
6	1	8041011	BACK SHEET
7	1	8040852	TOP SHEET
8	2	U120142	NUT, FLANGED LOCK 1/4-20
9	1	8040592	RADIATER ACCESS PLATE
10	2	8040334	LATCH, SWELL
11	1	E250211	MANUAL BOX
12	1	8041012	FRONT SHEET
13	2	8040588	OFFSET HINGE TYPE B
	8	U030525	SCREW, PAN HD #10-32X1/2
14	1	8040745	DOOR, CONTROL
15	1	8041013	SIDE PANEL W/ GAUGES
16	2	8040586	LATCH, LEVER LOCKABLE
*	72	U000060	SCREW, HC 1/4-20X1
*	126	U200020	WASHER, FLAT 1/4
*	72	U210020	WASHER, LOCK 1/4
*	54	U100020	NUT, HEX 1/4-20
*	1	8041171	HANDLE
	2	U001017	SCREW, HSH 1/4-20 X 1.25
	2	U200020	WASHER, FLAT 1/4
	2	U120100	NUT, HEX LOCK 1/4-20
*	4	8041483	DOOR SEAL VERTICAL
*	4	8041484	DOOR SEAL HORIZONTAL

\* NOT SHOWN

## VACASSY406

ITEM	QTY	NUMBER	DESCRIPTION
1	2	8030443	80-12V SOLENOID
2	1	8030455	MURPHY SWITCH
3	5	8030457	PANEL LIGHTS
4	1	8030456	HOUR METER
5	1	8030458	KEY SWITCH
	1	8030829	KEYS
6	1	8031257	FUSE PANEL 8 POS.
	7	8030461	5 AMP FUSE
7	1	8030330	FUEL GAUGE
8	1	X000021	ROCKER SWITCH THROTTLE HIGH/LOW
9	1	8041077	SWITCH, TANK RAISE/LOWER
10	1	8031231	SWITCH, DELAY RELAY
11	1	X000095	SWITCH, WORK LIGHTS
12	1	X000095	SWITCH, FULL TANK OVERRIDE
13	1	X000095	SWITCH, WATER PUMP CLUTCH
14	1	X000092	SWITCH, AUTOMATIC THROTTLE
	2	8030826	INLINE 20AMP FUSE
*	2	8030365	20 AMP FUSE
*	1	8041268	SWITCH, ANTIFREEZE
*	2	8031292	DIODE NTE 5809

\* NOT SHOWN

## VACASSY501

# Water Tank Assembly

# V800HD

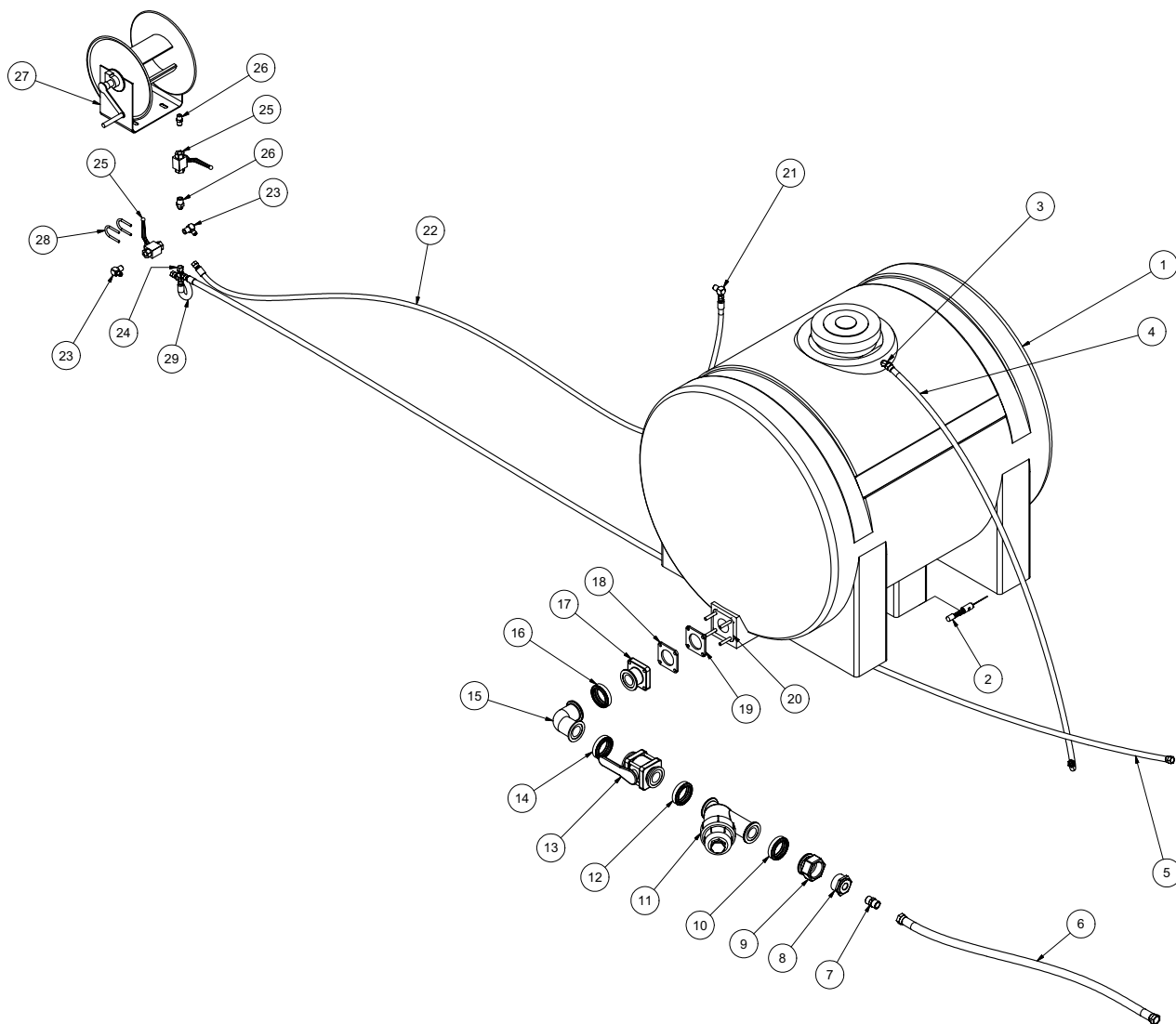

VACASSY604

# Water Tank Assembly

## V800HD

ITEM	QTY	NUMBER	DESCRIPTION
1	1	8030338	230 GALLON WATER TANK
	2	8040084	WATER TANK STRAP
	1	8030931	WATER TANK LID
2	1	8030343	LOW WATER LEVEL SWITCH
3	1	8030518	BULKHEAD 45 DEG, 8MJ
4	1	8041465	HOSE VAC PUSH 8-66
	2	8030524	PUSH LOCK HOSE FITTING 8FJ
5	1	8041466	HOSE ASSY VAC 8-160 ST-ST
6	1	8041467	HOSE VAC PUSH 12-36
	2	8030524	PUSH LOCK HOSE FITTING 12FJ
7	1	T400100	UNION, 3/4MP - 12MJ
8	1	8031134	BUSHING, 2" X 3/4" NPT BANJO
9	1	8030996	ADAPTER, FEMALE 2" BANJO
10	1	8031000	CLAMP, WATER MANIFOLD
11	1	8031001	Y-STRAINER, 2" BANJO
12	1	8031000	CLAMP, WATER MANIFOLD
13	1	8030998	BALL VALVE, 1-1/2 ID BANJO
14	1	8031000	CLAMP, WATER MANIFOLD
15	1	8030995	ELBOW, 2" BANJO
16	1	8031000	CLAMP, WATER MANIFOLD
17	1	80309971	FLANGE, 2" BANJO
18	1	80309972	FLANGE GASKET, 2" BANJO
19	1	80309972	FLANGE GASKET, 2" BANJO
20	1	80309973	FLANGE BOLTED, 2" BANJO
	4	U100060	NUT, HEX 3/8-16
	4	U210060	WASHER, LOCK 3/8
21	1	T401102	ELBOW, 6MJ - 3/8MP
22	1	8041468	HOSE ASSY VAC 8-130 ST-ST
23	2	T401102	ELBOW, 6MJ - 3/8MP
24	1	T402153	TEE, 6MJ - 6MJ - 6FJ
25	2	8030351	BALL VALVE, STEEL 3/8FJ
26	2	T400028	UNION, 6MJ - 3/8MP
27	1	8030346	HOSE REEL
	4	U000420	SCREW, HC 3/8"-16 X 1.0
	8	U200060	WASHER, FLAT 3/8"
	4	U210060	WASHER, LOCK 3/8"
	4	U100060	NUT, HEX 3/8"-16
28	2	U010017	UBOLT, 1/4 - 20 X 1-1/2
29	1	8041469	HOSE ASSY VAC 8-16 ST-ST

VACASSY604

# Reversible Flow

# V800HD

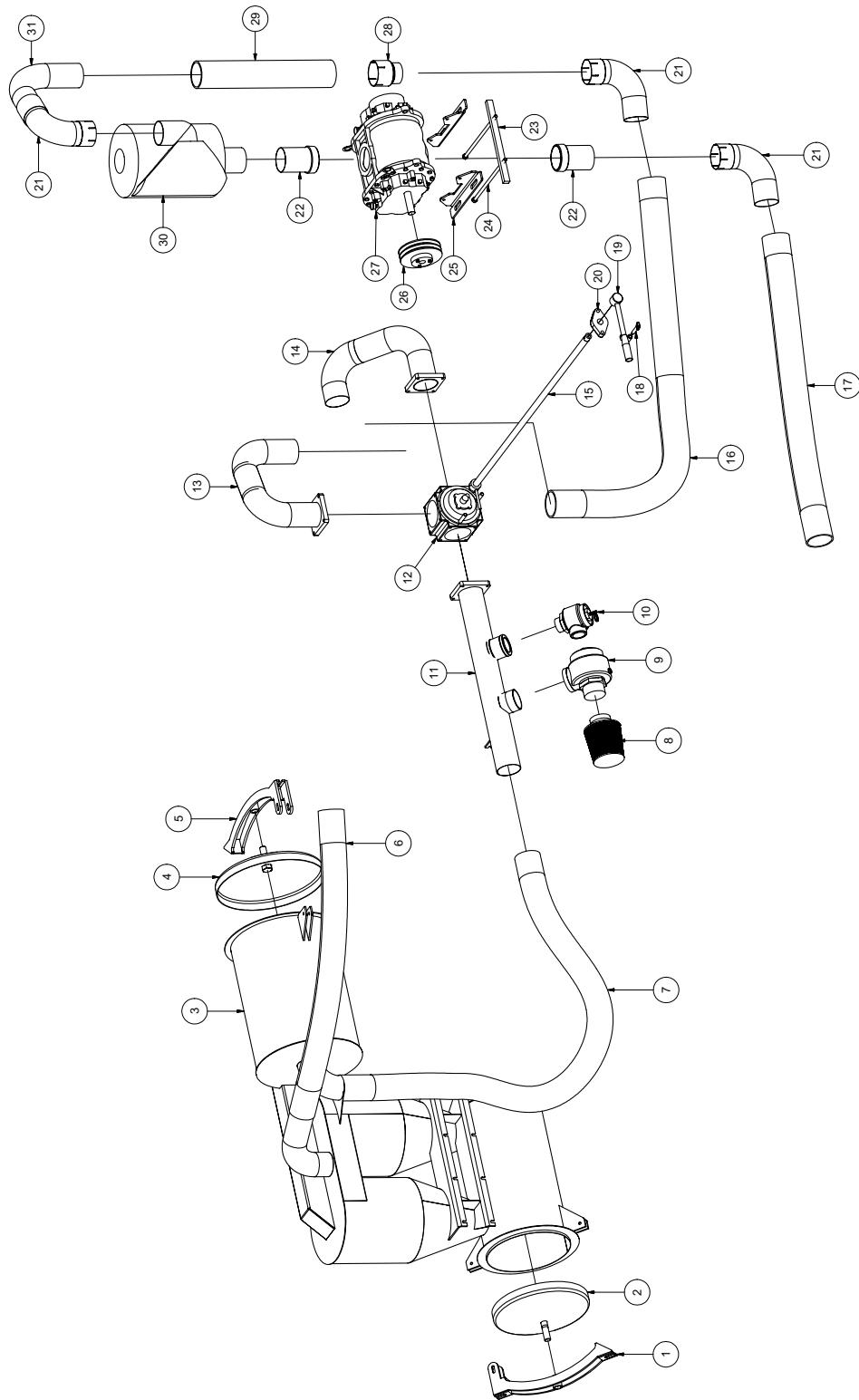

# Reversible Flow

# V800HD

ITEM	QTY	NUMBER	DESCRIPTION	ITEM	QTY	NUMBER	DESCRIPTION
1	1	8041552	DOOR LATCH CYCLONE	15	1	8042403	REV FLOW EXTENSION HANDLE
	1	U200170	WASHER, FLAT 1"	16	1	8042535	HOSE VAC WIREBRAID 4-80
	1	U120060	NUT,HEX NYLOCK 1"-8	17	1	8042536	HOSE VAC WIREBRAID 4-50
2	1	8041402	HD CYCLONE DOME ASSY	18	1	8041595	SPRING PLUNGER
3	1	8041659	CYCLONE/FILTER HOUSING		1	U160018	NUT, HEX NYLOCK 1/2"-13
	1	8031293	HD AIR FILTER	19	1	8041751	VALVE HANDLE
	1	8041612	CYCLONE SEAL	20	1	W030080	FLANGE BEARING
	1	8041613	AIR FILTER SEAL	21	3	8040929	4" ELBOW IDOD
	4	8041593	EYEBOLT 1/2"-13 X 6"	22	2	8030560	EXHAUST ADAPTER 4" MNPT - 4"OD
	4	8041594	HANDLE,WING 1/2"-13	23	1	8040904	TENSION BLOCK 1025CFM
	2	U000500	SCREW,HC 3/8"-16 X 2"	24	2	8041507	ROD TIGHTENER WELD'T
	2	U000560	SCREW,HC 3/8"-16 X 3"	25	2	8040710	BLOWER FOOT (MODEL 59)
	8	U00420	SCREW,HC 3/8"-16 X 1"	26	1	8040484	SHEAVE 6.95 OD SDS 2-GROOVE
	32	U200060	WASHER,FLAT 3/8"		1	8040485	BUSHING 1 1/8" SDS
	12	U210060	WASHER,LOCK 3/8"		1	U410090	KEY 1/4" X 1/4" X 2 3/4"
	4	U210061	NUT,HEX NYLOCK 3/8"-16	27	1	8040001	BLOWER (MODEL 59)
4	1	8041387	HD AIR FILTER DOME ASSY	4	U000817	SCREW, HC 1/2" - 13 X 1"	
5	1	8041554	DOOR LATCH HDAIR FILTER	4	U210100	WASHER, LOCK 1/2"	
	1	U200170	WASHER, FLAT 1"	4	U200100	WASHER, FLAT 1/2"	
	1	U120060	NUT,HEX NYLOCK 1"-8	28	1	8031044	ADAPTER 3"MNPT 4"ID
6	1	8042533	HOSE VAC WIREBRAID 4-54	29	1	8041742	HOSE VAC WIREBRAID 4-24
7	1	8042534	HOSE VAC WIREBRAID 4-97	30	1	8041611	SILENCER,1025 CFM,
8	1	8041598	KUNKLE FILTER 1025	31	1	8030398	ELBOW 4" (6"RAD ID-OD)
9	1	8030866	KUNKLE VALVE, 1025 CFM	*	11	8031193	EXHAUST CLAMP
10	1	8041035	PRESSURE RELIEF 1025	*	1	8030400	BAND CLAMP
11	1	8042395	REV FLOW HEADER	*	1	8042537	HOSE ASSY VAC 4-150 ST-ST
12	1	8041177	4 WAY VALVE	*	1	8041074	GAUGE, COMPOUND VAC/PRESSURE
	4	U001080	SCREW,HC 1/2"-13 X 7.5"	*	1	T401100	ELBOW, 90 4MP-4MJ
	12	U200100	WASHER,FLAT 1/2"				
	4	U210111	WASHER,LOCK 1/2"				
	4	U100120	NUT,HEX 1/2"-13				
13	1	8042396	REV FLOW INLET ELBOW				
14	1	8042417	REV FLOW INLET/OUTLET				

# Trailer Assembly

# V800HD

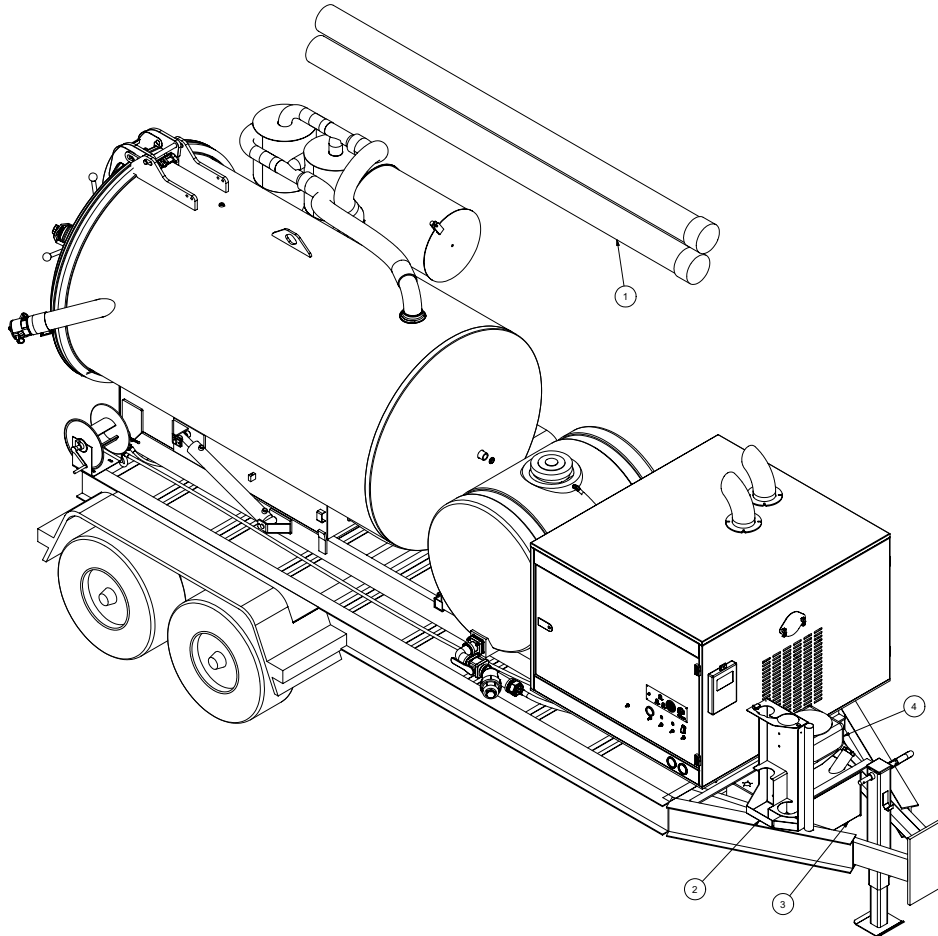

# Tools

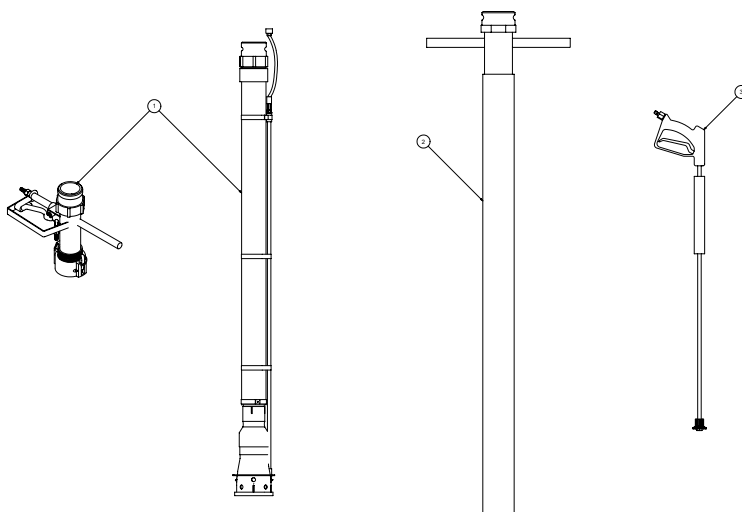

VACASSY702

# Trailer Assembly

# V800HD

ITEM	QTY	NUMBER	DESCRIPTION	
1	4	8041102	HOSE STORAGE 6" X 10'	
	4	8030925	END CAP 6"	
	4	R700160	R CLIP	
	4	8041101	HOSE STORAGE RETAINING ROD	
	4	8041485	LANYARD CABLE	
	6	8040959	HOSE STORAGE CLAMP	
	12	U200060	WASHER, FLAT 3/8	
	12	U100060	NUT, HEX 3/8	
	2	1	8040985	TOOL RACK
		1	8040989	TOOL RACK CLOSURE
		1	8041779	TOOL RACK BRACKET
		1	8041780	ENCLOSURE SUPPORT BRACKET
1		8041804	TOOL RACK PULL BAR	
1		R700175	R CLIP 7/8"	
1		8041259	STRAP, 10"	
1		8041485	LANYARD CABLE	
3		1	8040763	FUEL TANK (20 GAL)
		1	36201441	FUEL CAP
	1	8030697	FUEL SENDING UNIT	
	1	8030656	FUEL FILTER	
4	1	8030394	ANTI-FREEZE TANK (4 GAL)	
	4	U000180	SCREW, HC 5/16"-18 X .75"	
	4	U200040	WASHER, FLAT 5/16	
	4	U210040	WASHER, LOCK 5/16	
	1	T403100	UNION 12FP 20MP	
	1	T401040	ELBOW 90 12MP 12MP	
	1	T000185	BALL VALVE 3/4" FP	
	1	T400080	UNION 8MJ - 12MP	
	2	8030524	# 8 FJ PUSHLOCK	
	1	8041470	HOSE VAC PUSH 8-36	
	*	2	8041263	PLASTIC STRIP
	*	1	8042433	SKID WELDMENT
*	6	8040038	U-BOLT SKID TO TRAILER	
	6	8040240	U-BOLT MTG. BLOCK	
	12	U200100	WASHER, FLAT 1/2"	
	12	U100120	NUT, HEX 1/2"-13	
*	2	8042482	HOSE STORAGE BRACKETS	

\* NOT SHOWN

## Tools

Item	Qty	Number	Description	Item	Qty	Number	Description		
1	1	8041908	TOOL VAC REDUCTION HD COMPLETE	*	2	8041100	VACUUM HOSE ASSEMBLY 4" X 10'		
	1	8030635	TOOL VAC HEAD ASSY 3"		1	8030844	BANJO 4" MALE		
	2	8030486	QUICK DISCONNECT SS		1	8030846	BANJO 4" FEMALE		
	1	8031079	BANJO 3" MALE		2	8030560	HOSE ADAPTER 4"		
	1	8030392	BANJO 3" FEMALE		1	8040339	VACCUM HOSE 4" KANAFLEX		
	1	8030928	TRIGGER ASSEMBLY		*	1	8041080	ADAPTER 3" TO 4"	
	1	8041099	TOOL VAC REDUCTION HD LOWER ASSY		*	1	8041830	HIGH PRESSURE WATER HOSE	
	2	8030370	REDUCTION TOOL NOZZLE		*	1	8030504	REDUCER 3/8"FP - 1/4"MP	
	2	8031268	REDUCTION TOOL NOZZLE 45 DEG		*	1	8030487	Q.D. FEMALE 1/4"FP	
	1	8031079	BANJO 3" MALE						
			8040333		REDUCTION TOOL COLLAR				
	2	1	8040983		TOOL VAC SUCTION 4" COMPLETE	*			NOT SHOWN
	3	1	8030348		TOOL VAC SPRAY WAND COMPLETE				
		1	8030928		TRIGGER ASSEMBLY				
1		8030847	WAND						
	1	8031308	NOZZLE						

VACASSY702





# WIRING SCHEMATIC

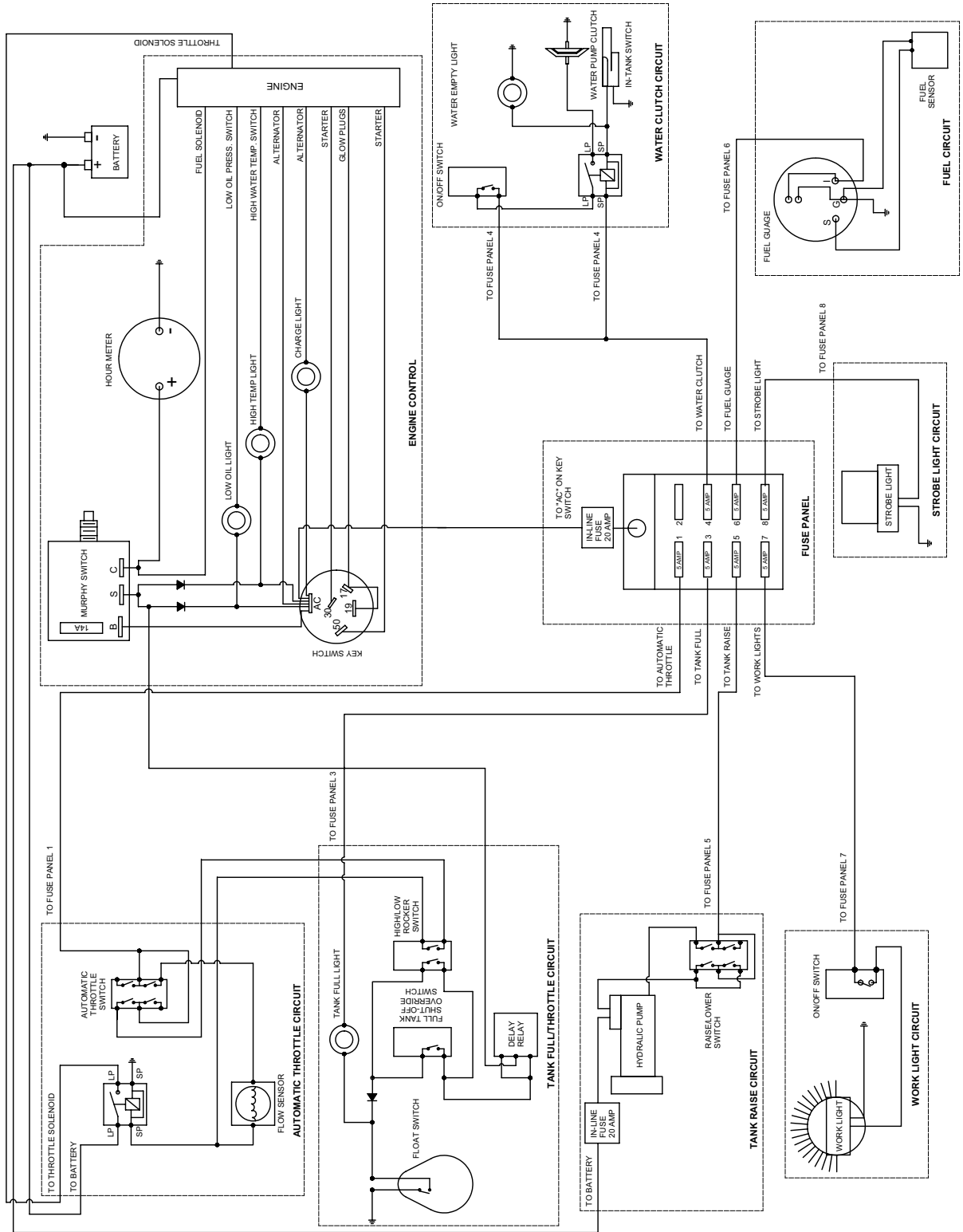



# WARRANTY RETURN GOODS POLICY

## LIMITED WARRANTY

The Manufacturer warrants its products to be free from defects in material and workmanship for a period of twelve months from the date of shipment from the factory. The Manufacturer shall not be responsible for any damage resulting to or caused by its products by reason of installation, improper storage, unauthorized service, alteration of the products, neglect or abuse, or use of the product in a manner inconsistent with its design. The warranty does not extend to any component parts not manufactured by Manufacturer; however, Manufacturer's warranty herein shall not limit any warranties made by manufacturers of component parts which extend to Buyer.

Claims for defects in material and workmanship shall be made in writing to Manufacturer within ten days of discovery of defect. Manufacturer may either send a service representative or have the product returned to its factory at Buyer's expense for inspection. Upon notification of defect, Manufacturer will issue a return goods authorization number to Buyer. The return goods authorization number must accompany the product returned. If judged by the Manufacturer to be defective in material or workmanship, the product will be replaced or repaired at the option of the Manufacturer, free from all charges except authorized transportation. Buyer shall be responsible for all maintenance services consisting of lubrication and cleaning of equipment, replacing expandable parts, making minor adjustments, and performing operating checks, all in accordance with procedures outlined in Manufacturer's maintenance literature.

THE FOREGOING WARRANTY IS IN LIEU OF ALL OTHER WARRANTIES AND NO REPRESENTATIONS, GUARANTEES, OR WARRANTIES, EXPRESS OR IMPLIED, (INCLUDING BUT NOT LIMITED TO A WARRANTY OF MERCHANTABILITY OR FITNESS FOR A PARTICULAR PURPOSE), ARE MADE BY THE MANUFACTURER IN CONNECTION WITH THE MANUFACTURE OR SALE OF ITS PRODUCTS. NO EMPLOYEE, DISTRIBUTOR, OR REPRESENTATIVE IS AUTHORIZED TO CHANGE THIS WARRANTY ON BEHALF OF MANUFACTURER. THE REMEDIES OF BUYER SET FORTH HEREIN ARE EXCLUSIVE AND ARE IN LIEU OF ALL OTHER REMEDIES. THE LIABILITY OF MANUFACTURER WHETHER IN CONTRACT, TORT, UNDER ANY WARRANTY, OR OTHERWISE SHALL NOT EXTEND BEYOND ITS OBLIGATION TO REPAIR OR REPLACE, AT ITS OPTION ANY PRODUCT OR PART FOUND BY MANUFACTURER TO BE DEFECTIVE IN MATERIAL OR WORKMANSHIP. MANUFACTURER SHALL NOT BE LIABLE FOR COST OF INSTALLATION AND/OR REMOVAL OR BE RESPONSIBLE FOR DIRECT, INDIRECT, SPECIAL OR CONSEQUENTIAL DAMAGES OF ANY NATURE.

## GENERAL RETURNS OF MERCHANDISE

1. All returns must be pre-authorized
  - A. Please call our parts department for an RGA number
  - B. Please include RGA number on the outside of box
  - C. Include any required paper work or special instructions
  - D. Items returned without an RGA number will not be accepted
2. All returns are subject to a 20% restock charge.
3. Special items are non-returnable
  - A. Non-stock parts
  - B. Custom parts
  - C. If you are unsure about a parts status when ordering, ask your McLaughlin representative if the item fits on of the above conditions.
4. Items must be returned within thirty days of original order date.
5. Items not returned within 30 days from the date of RGA is issued will not be accepted.
6. The item(s) must be in new condition. Used item(s) are not returnable.



# Notes

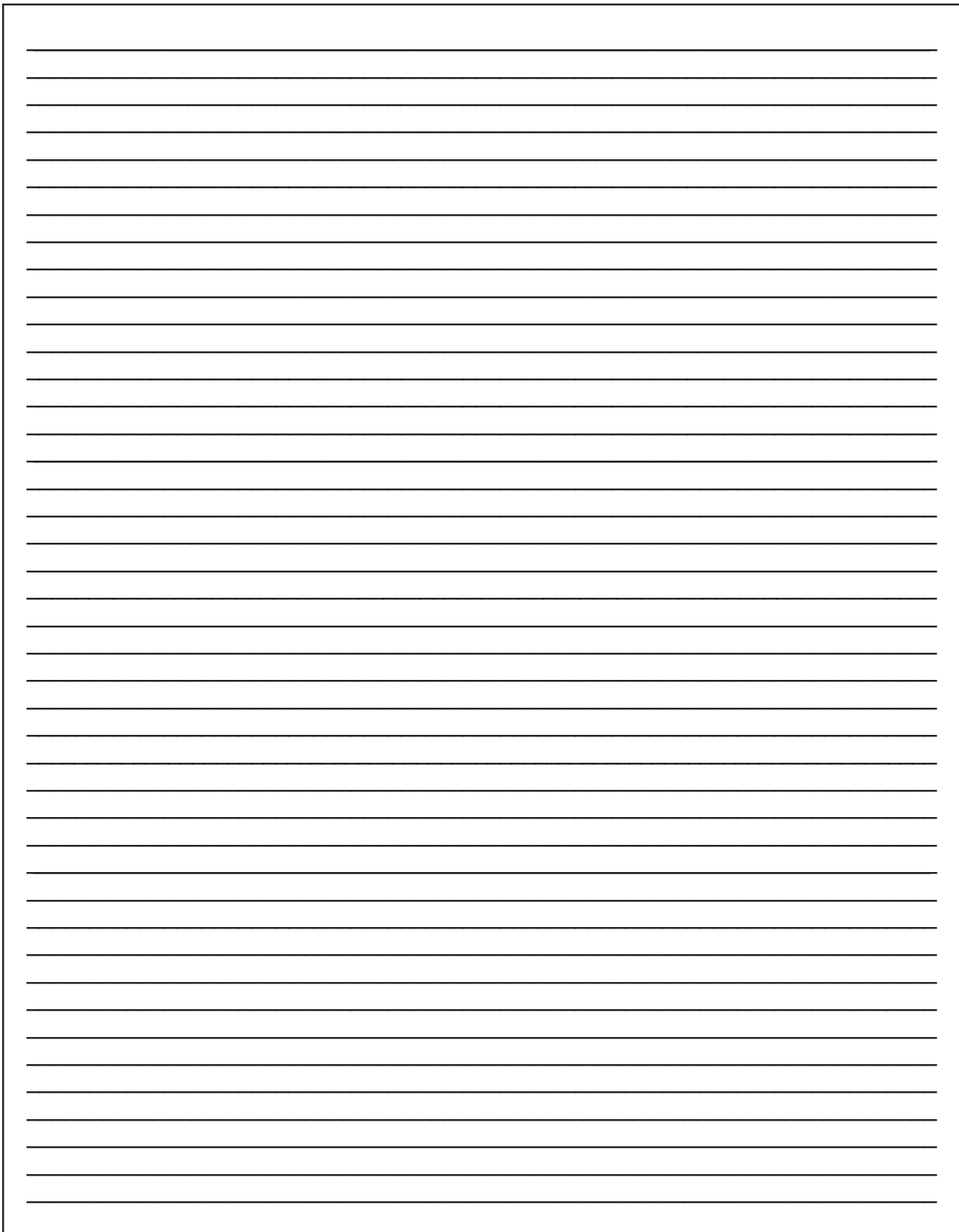

A large rectangular box containing 30 horizontal lines for writing notes. The lines are evenly spaced and extend across the width of the box. The box is empty, with no text or other markings inside.