



**McLAUGHLIN®**

2006 Perimeter Road. Greenville, SC 29605  
Toll Free: 800/435-9340 - Phone: 864/277-5870  
Fax: 864/235-9661 - Website address: [www.mclaughlinunderground.com](http://www.mclaughlinunderground.com)  
Email address: [mmole@mightymole.com](mailto:mmole@mightymole.com)

**Parts Manual  
Vermeer/ McLaughlin  
VX30-500G  
VX30-800G  
VX30-1200G  
Vacuum Machine  
Part #E850505  
(SERIAL # 091214773 - PRESENT)**

© 2014 by McLaughlin Group, Inc.

040414

All rights reserved. No part of this manual may be reproduced in any form, or by any means without prior written permission of McLaughlin Group, Inc.



# Table of Contents

## PARTS

### SPOIL TANK AND FILTRATION

MANUAL/HYDRAULIC DOOR .....	4
HYDRAULIC DOOR CYLNDER .....	10
FILTRATION .....	12

### ENGINE COMPARTMENT

ENGINE .....	14
BLOWER .....	16
WATER PUMP .....	20
REGULATOR .....	24
ELECTRICAL .....	26
HYDRAULIC PUMP .....	28

### WATER TANK AND ACCESSORIES

WATER TANKS - 125 GALLON SADDLE.....	30
WATER TANKS - 50 GALLON SADDLE.....	32
ANTIFREEZE ASSEMBLY .....	34
HOSE REEL .....	36

### TRAILER AND SKID ASSEMBLY

TRAILER .....	44
SKID ASSEMBLY .....	48
HYDRAULIC JACK OPTION .....	58
SURGE BREAK OPTION .....	60

### TOOLS

HOSES .....	62
REDUCTION TOOL .....	64
VACUUM TOOL .....	66
WASH WAND .....	68
VALVE BOX CLEAN OUT TOOL .....	70
ROTARY LANCE .....	72
LAWN SWEEPER .....	74
SURFACE CLEANER .....	76

## ELECTRICAL SCHEMATICS

ELECTRICAL .....	79
------------------	----

## HYDRAULIC SCHEMATICS

TANK AND OPTIONAL JACK .....	80
------------------------------	----

## MAINTENANCE MANUALS

ROOTS BLOWER .....	82
ENGINE .....	92

## WARRANTY

# Tank and Door Assembly

# V500

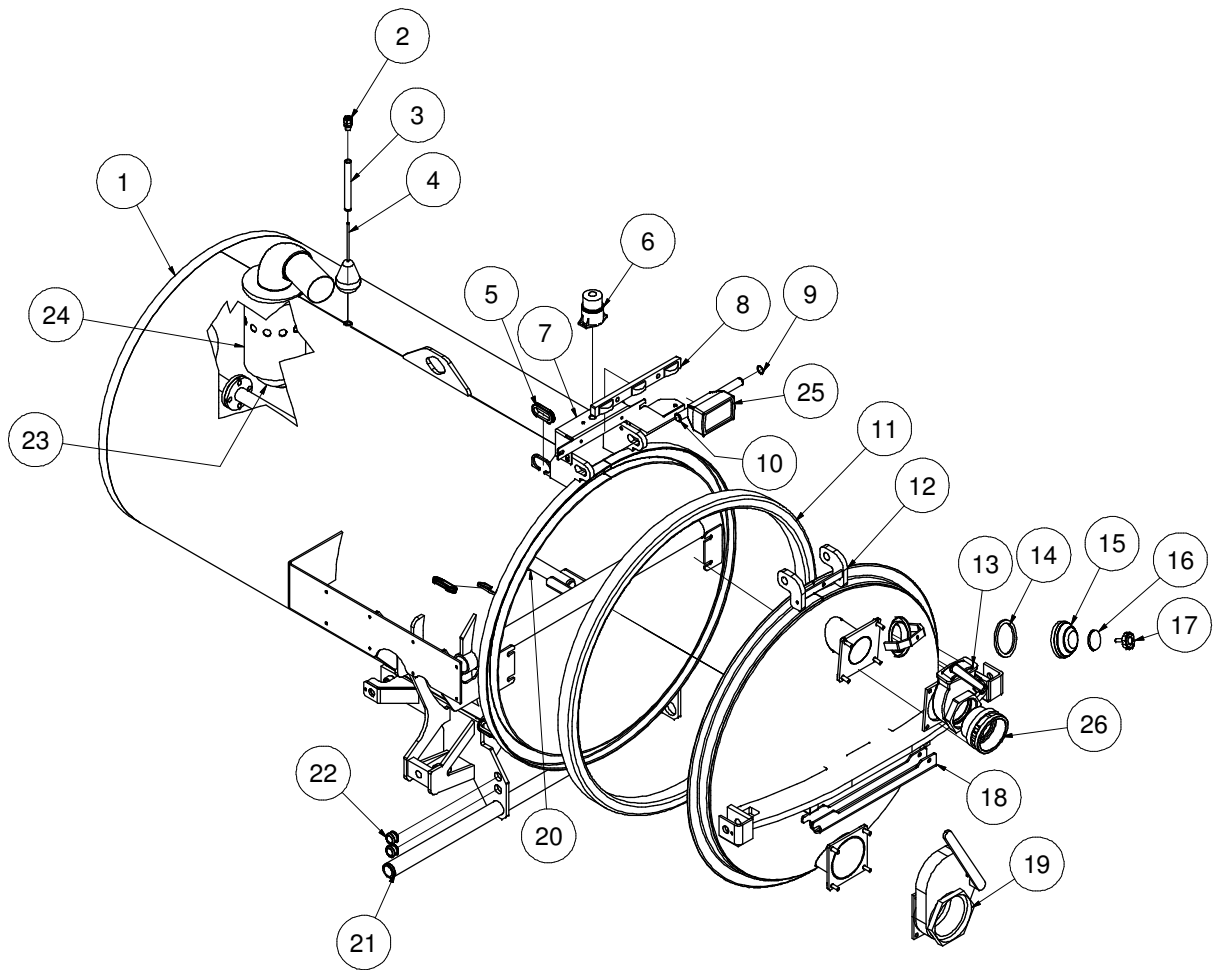

041015-E

VACASSY031

# Tank and Door Assembly

# V500

ITEM	QTY	PART NO.	DESCRIPTION
1	1	8045737	TANK WELDMENT - 500LE (42"DIA)
	1	T400310	REDUCER, 1"MB - 3/8"MJ
2	1	X000113	STRAIN RELIEF, 1/2"
3	1	8040769	HIGH LEVEL FLOAT SWITCH TUBE
	1	8041291	BUSHING, RUBBER
4	1	8030531	HIGH LEVEL FLOAT SWITCH
5	4	8042812	GROMMET 2"ID 3"OD 1/4"WOG TRAILER SLOT MODEL
6	1	8043139	STROBE LIGHT
	3	U010006	SCREW, PHILLIPS #10 - 24 X 1"
	3	U210005	WASHER, LOCK #10
	3	U100010	NUT, HEX #10 - 24
7	1	8046507	STROBE LIGHT BRACKET
	4	X000343	DT MOUNTING CLIP
	4	U000880	SCREW, HC 1/2" - 13 X 2.00"
	4	U200100	WASHER, FLAT 1/2"
	4	U210111	WASHER, LOCK 1/2"
	4	U100200	NUT, HEX 1/2" - 13
8	1	8041509	LIGHT CLEARANCE 3 BAR
9	2	U500080	RING,RET E-RING .375 SHAFT
10	1	8040058	DOOR HINGE ROD
11	1	8041765	DOOR SEAL 42" DIA TANK
12	1	8047770	DOOR WELDMENT - 500 (42" DIA)
13	1	8046215	VALVE, 4" GATE BRASS LEVER FLANGE (500LEHD/800LEHD)
*	1	8046231	O-RING, GATE VALVE FLANGE
*	1	8042408	VALVE, 3" GATE BRASS LEVEL TYPE (500LE/800LE)
*	1	8046197	GATE VALVE TANK FLANGE 3"
*	1	8046191	GASKET DOOR LE INLET/OUTLET
14	1	8031049	GASKET, 4" COUPLER
15	1	8031048	SIGHT GLASS
16	1	8031047	SIGHT GLASS PLATE
17	1	8031046	SIGHT GLASS HAND WHEEL
18	1	8041212	TANK SAFETY BRACE
19	1	8046214	VALVE, 6" GATE BRASS LEVER FLANGE
*	1	8030849-50	HANDLE, 6" GATE VALVE (RIV MODEL)
*	1	8046191	GASKET DOOR LE INLET/OUTLET
20	1	8043166	500HLD TANK ROD WELDMENT
*	3	8030369	NOZZLE, TANK CLEAN OUT
*	1	W200120	O-RING 1 7/8" X 2 1/8" X 1/8" (225)
21	1	8042648	TANK PIVOT ROD
	2	U200180	WASHER, FLAT 2"
	2	U120120	LOCK NUT
	2	U000900	SCREW, HC 1/2"-13 X 2 1/2"LG
22	4	8041686	GROMMET 1"ID - 1 1/4"DOG - 1/4"WOG
23	1	8043700	BALLFLOAT SHUTOFF WELDMENT
	2	U000420	SCREW, HC 3/8"-16 X 1.00"
	2	U210060	WASHER, LOCK 3/8"
	2	U200600	WASHER, FLAT 3/8"
	1	8043571	SEAT 4" RUBBER
	1	8043572	SEAT CLAMP 4"
24	1	8043570	BALL STRAINLESS FLOAT 6"
25	1	8043138	WORK LIGHT
26	1	8046445	CAMLOCK, 4" AL FCAM X MNPT

\* NOT SHOWN

041015-E

VACASSY031

# Tank and Door Assembly

# V800LE

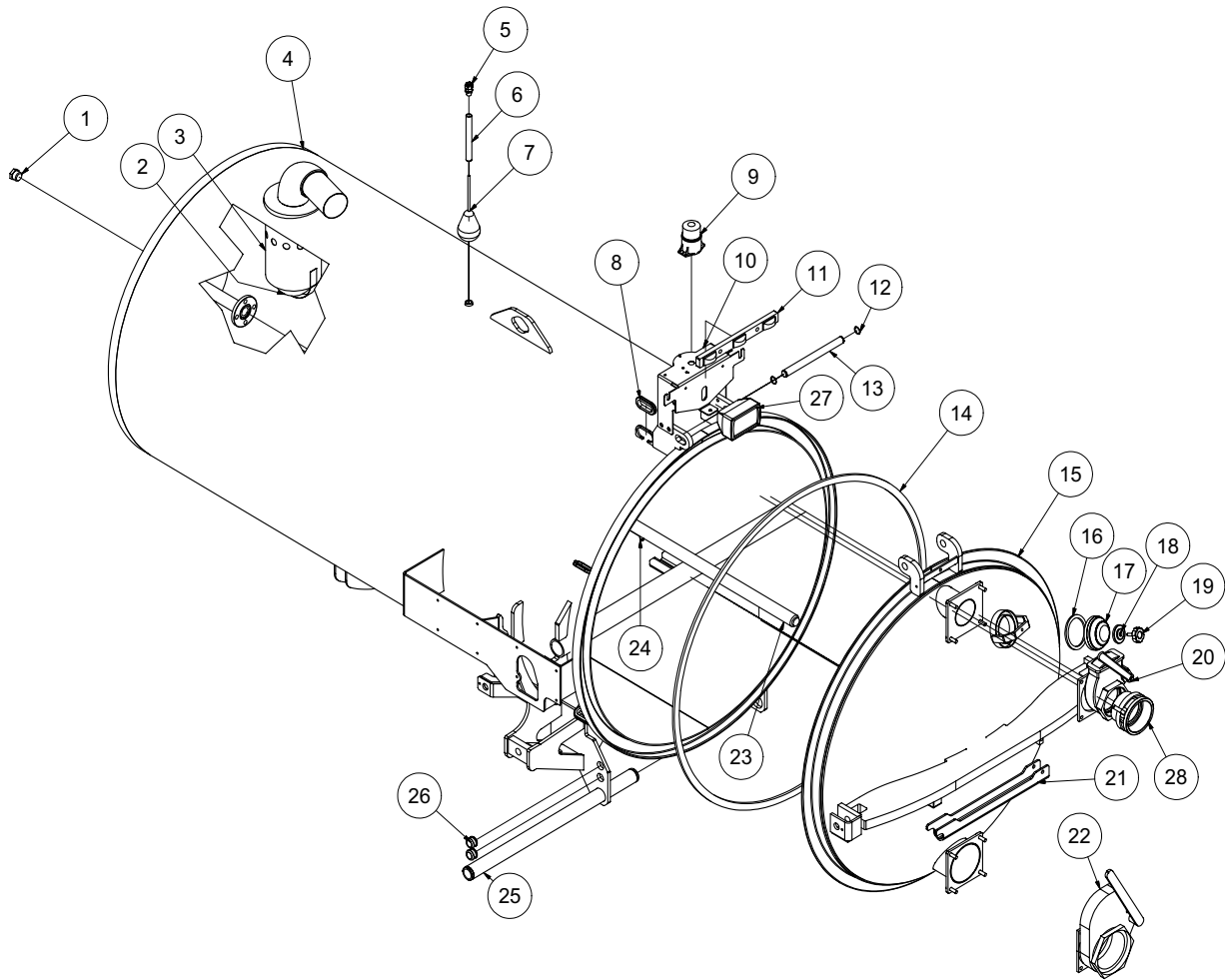

041315-E

VACASSY032

# Tank and Door Assembly

# V800LE

ITEM	QTY	PART NO.	DESCRIPTION
1	1	T400310	REDUCER, 1"MB - 3/8"MJ
2	1	8043570	BALL STAINLESS FLOAT 6"
3	1	8043700	BALL FLOAT SHUTOFF WELDMENT
	2	U000420	SCREW, HC 3/8"-16 X 1.00"
	2	U210060	WASHER, LOCK 3/8"
	2	U200600	WASHER, FLAT 3/8"
	1	8043571	SEAT 4" RUBBER
	1	8043572	SEAT CLAMP 4"
4	1	8046150	TANK WELDMENT - 800LE (48"DIA)
5	1	X000113	STRAIN RELIEF, 1/2"
6	1	8040769	HIGH LEVEL FLOAT SWITCH TUBE
7	1	8030531	HIGH LEVEL FLOAT SWITCH
8	4	8042812	GROMMET 2"ID3"OD1/4" WOG TRAILER SLOT MODEL
9	1	8043139	STROBE LIGHT
	3	U010006	SCREW, PHILLIPS #10-24 X 1"
	3	U210005	WASHER, FLAT 1/2"
	3	U100010	NUT HEX, #10 - 24
10	1	8046507	STROBE LIGHT BRACKET WELDMENT
	4	X000343	DT MOUNTING CLIP
	4	U000880	SCREW, HC 1/2"-13 X 2.00"
	4	U200100	WASHER, FLAT 1/2"
	4	U210111	WASHER, LOCK 1/2"
	4	U100200	NUT, HEX 1/2" - 13
11	1	8041509	LIGHT CLEARANCE 3 BAR
12	2	U500020	SNAP RING, EXT 1" SHAFT ZP
13	1	8040058	DOOR HINGE ROD
14	1	8041766	SEAL, DOOR SQ V750/V800LE 154"
15	1	8047771	DOOR 800 (48")- WELDMENT
16	1	8031049	GASKET, 4" COUPLER
17	1	8031048	SIGHT GLASS
18	1	8031047	SIGHT GLASS PLATE
19	1	8031046	SIGHT GLASS HAND WHEEL
20	1	8046215	VALVE, 4" GATE BRASS LEVER FLANGE (500LEHD/800LEHD)
*	1	8046231	O-RING, GATE VALVE FLANGE
*	1	8042408	VALVE, 3" GATE BRASS LEVER TYPE (500LE/800LE)
*	1	8046197	GATE VALVE TANK FLANGE 3"
*	1	8046191	GASKET DOOR LE INLET/OUTLET
21	1	8041212	TANK SAFETY BRACE
22	1	8046214	VALVE 6" GATE BRASS LEVER
	1	8030849-50	HANDLE, 6" GATE VALVE (RIV MODEL)
	1	8046191	GASKET DOOR LE INLET/OUTLET
23	1	8046172	TANK ROD 800LE WELDMENT
*	1	W200120	O-RING, 1 7/8" X 2 1/8" X 1/8" (225)
24	3	8030369	NOZZLE, TANK CLEANOUT
25	1	8042648	TANK PIVOT ROD
	2	U200180	WASHER FLAT 2"
	2	U120120	LOCK NUT
	2	U000900	SCREW, HC 1/2" - 13 X 2 1/2" LG
26	4	8041686	GROMMET 1"ID- 1 1/4"DOG - 1/4"WO
27	1	8043138	WORKLIGHT
28	1	8046445	CAMLOCK, 4" AL FCAM X MNPT

\* NOT SHOWN

041315-E

VACASSY032

# Tank and Door Assembly

1200

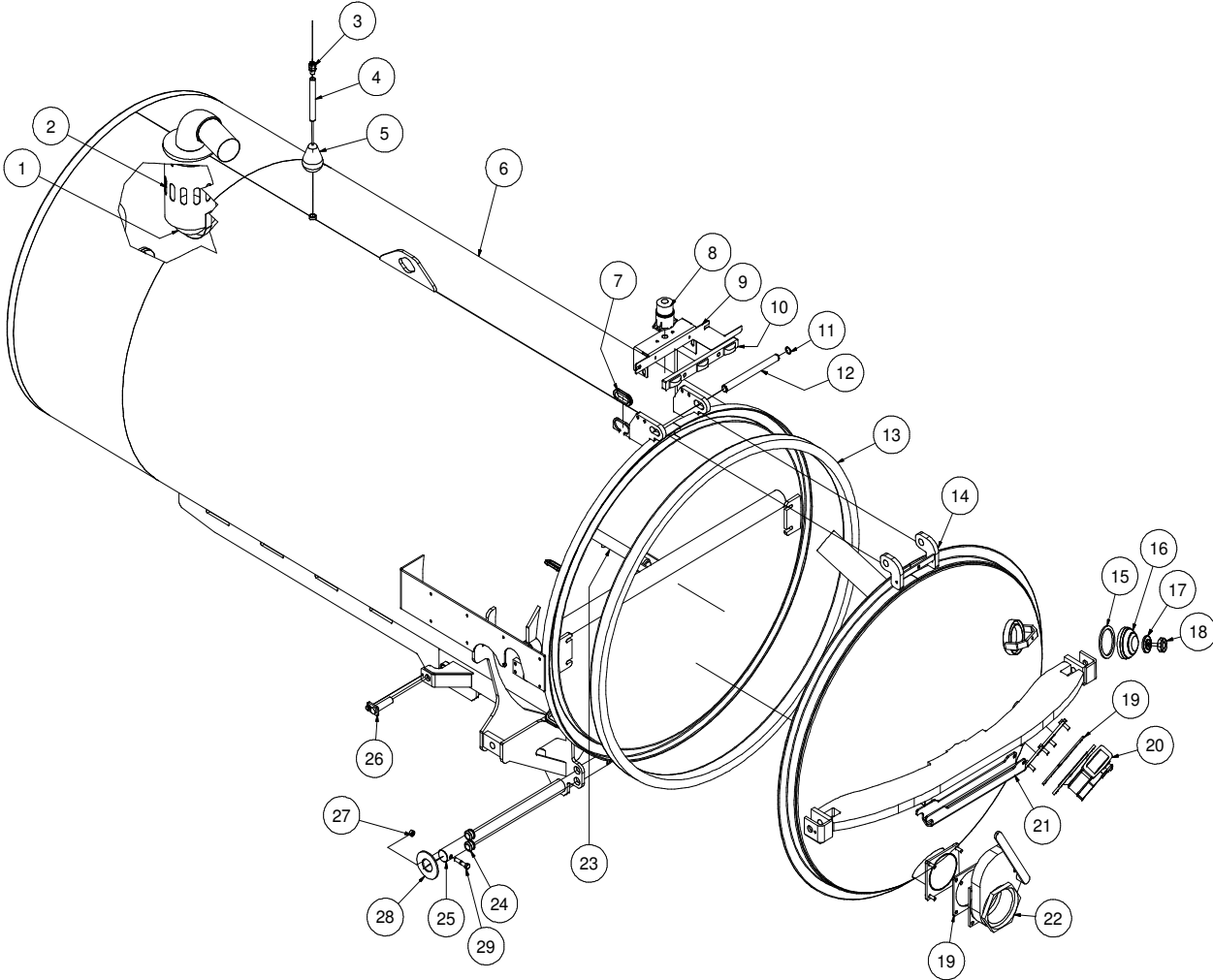

040413-E

VACASSY036



# Tank and Door Assembly

# 1200

ITEM	QTY	PART NO.	DESCRIPTION
1	1	8043570	BALL STRAINLESS FLOAT 6"
2	1	8043700	BALL FLOAT SHUTOFF WELDMENT
	2	U000420	SCREW, HC 3/8" - 16 X 1.00"
	2	U210060	WASHER, LOCK 3/8"
	1	8043571	SEAT 4" RUBBER
	1	8043572	SEAT CLAMP 4"
3	1	X000113	STRAIN RELIEF, 1/2"
4	1	8040769	HIGH LEVEL FLOAT SWITCH TUBE
5	1	8030531	HIGH LEVEL FLOAT SWITCH
6	1	8048450	TANK 1200 - WELDMENT
7	4	8042812	GROMMET 2"ID 3"OD 1/4"WOG TSM
8	1	8043139	LIGHT, STROBE LED DEUTSCH
	3	U010006	SCREW, PHILLIPS #10 - 24 X 1.00"
	3	U210005	WASHER, LOCK #10
	3	U100010	NUT, HEX #10 - 24
9	1	8046507	STROBE LIGHT BRACKET
	4	U000880	SCREW, HC 1/2" - 13 X 2.00"
	4	U200100	WASHER, FLAT 1/2"
	4	U210111	WASHER, LOCK 1/2"
	4	U100120	NUT, HEX 1/2"-13
	1	X000343	DT MOUNTING CLIP
10	1	8041509	LIGHT CLEARANCE BAR
11	2	8030362	1" SNAP RING
12	1	8040058	DOOR HINGE ROD
13	1	8041767	DOOR SEAL 54"DIA. TANK
14	1	8048453	DOOR 1200 WITH INLET (US)
	1	8048454	DOOR 1200 WITH INLET (AUS)
15	1	8032007	GASKET, 4" COUPLER
16	1	8031048	SIGHT GLASS
17	1	8031047	SIGHT GLASS PLATE
18	1	8031046	SIGHT GLASS HAND WHEEL
19	2	8046191	GASKET, INLET/OUTLET DOOR LE
20	1	8042408	3" GATE VALVE BRASS LEVEL TYPE
21	1	8041212	TANK SAFETY BRACE
22	1	8046214	VALVE, 6" GATE BRASS LEVER
	1	8030849-50	HANDLE, 6" GATE VALVE (RIV MODEL)
23	1	8043567	TANK ROD 1200 (54" DIA TANK)
	3	8030369	NOZZLE, TANK CLEANOUT
24	4	8041686	GROMMET 1"ID 1 1/4"DOG 1/4"WO
25	1	8047752	TANK PIVOT ROD
26	2	8040753	CYLINDER PIN WELDMENT
	2	U000400	SCREW, HC 3/8" - 16 X 1.00"
	2	U200600	WASHER, FLAT 3/8"
	2	U210060	WASHER, LOCK 3/8"
27	2	U160018	NUT, LOCK .500-13 NY ZP
28	2	U200180	WASHER FLAT 2.125ID X 4.5OD
29	2	U000900	SCREW, HC .500-13X2.50 ZP G5

\* NOT SHOWN

040413-E

VACASSY036

# Hyd. Door Cylinder Assembly

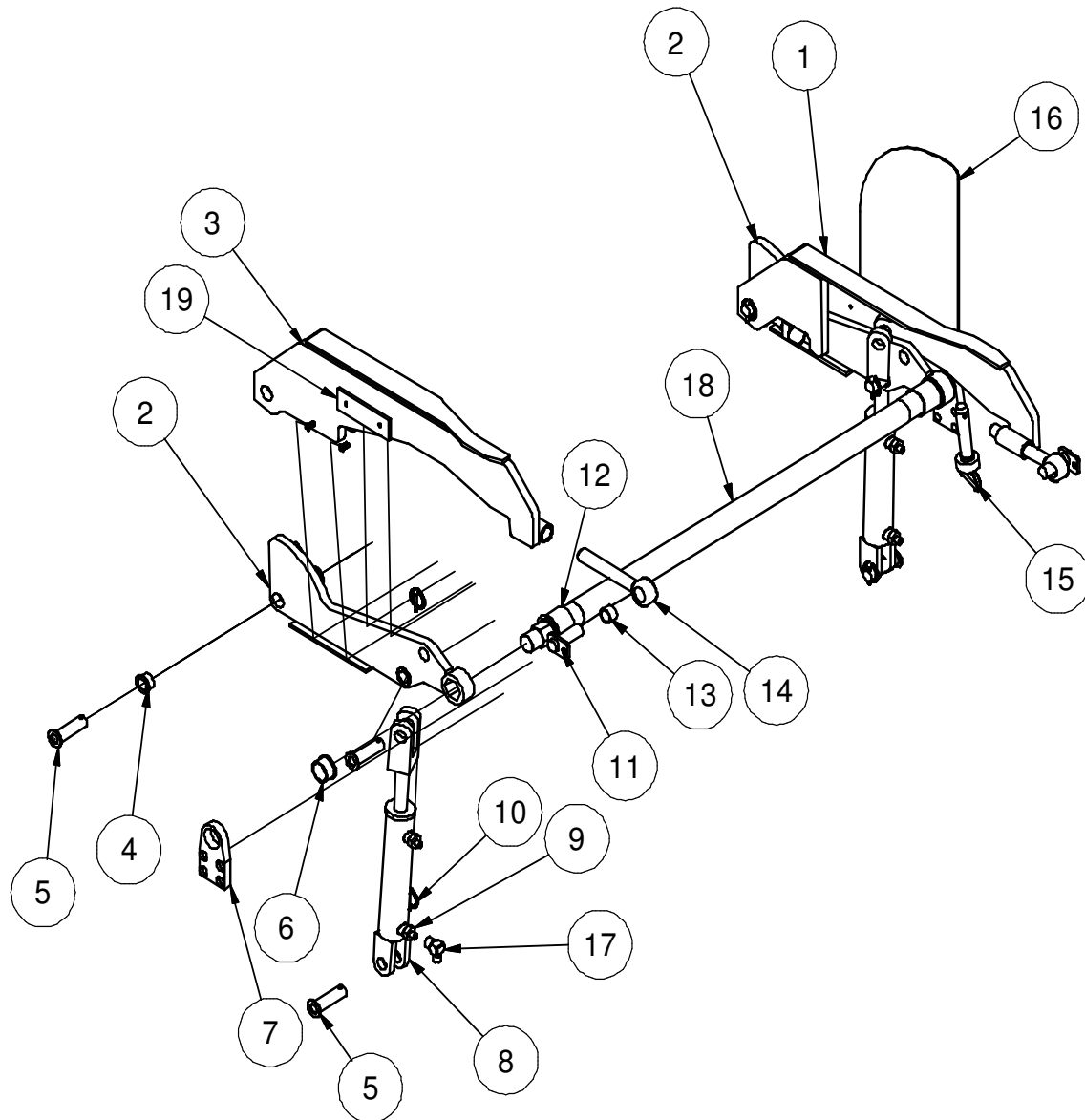

061413-E

VACASSY942

# Hyd. Door Cylinder Assembly

ITEM	QTY	PART NO.	DESCRIPTION
1	1	8041369	DOOR HYD LONG LINKAGE WELDMENT
2	2	8041604	SHORT LINKAGE WELDMENT
3	1	8041375	DOOR HYD LONG LINKAGE SS WELDMENT
4	6	8041883	BUSHING BRONZE FLANGED 1"
5	6	8042489	HYD DOOR - PIN WELDMENT 1"DIA X 3"
6	2	8041602	BUSHING 1 1/4" MODIFIED
7	1	8041783	OUTER BEARING PLATE
8	2	8041327	HYD CYLINDER - 8" STROKE
9	4	T400611	UNION 8MB - 4MJ
10	6	U340050	PIN LINCH 3/16 X 1 9/16
11	2	8043844	DOOR CAPTURE PIN
12	2	8041602	BUSHING BRONZE FLANGED 2"
13	2	8041524	BUSHING BRONZE 1 1/4" X 1.00 X 3/4"LG
14	2	8043131	ROD END 1" X 7 1/2"
	2	U160025	NUT, JAM 1.00"
	2	U120060	NUT, NY LOCK 1"
	4	U200170	WASHER, FLAT 1.00"
15	1	8041626	1" X 4 1/2" HITCH PIN
16	1	8041635	HYD ARM GUARD
17	1	T401225	ELBOW, 90 1/4MJ - 1/4FJ
18	1	8041607	LINKAGE CROSS TUBE V500
	1	8046186	LINKAGE CROSS TUBE V750 / V800LE
	1	8041663	LINKAGE CROSS TUBE V800 / V1200
19	2	8049376	PLASTIC STRIP, 1/4" X 2" X 6"LG
	4	U030017	SCREW,SFH .250-20X1.00 ZP
	4	U120000	NUT,LOCK, NY, .250-20 ZP G2
	4	U200020	WASHER FLAT .250 ZP

# Filtration

500/575

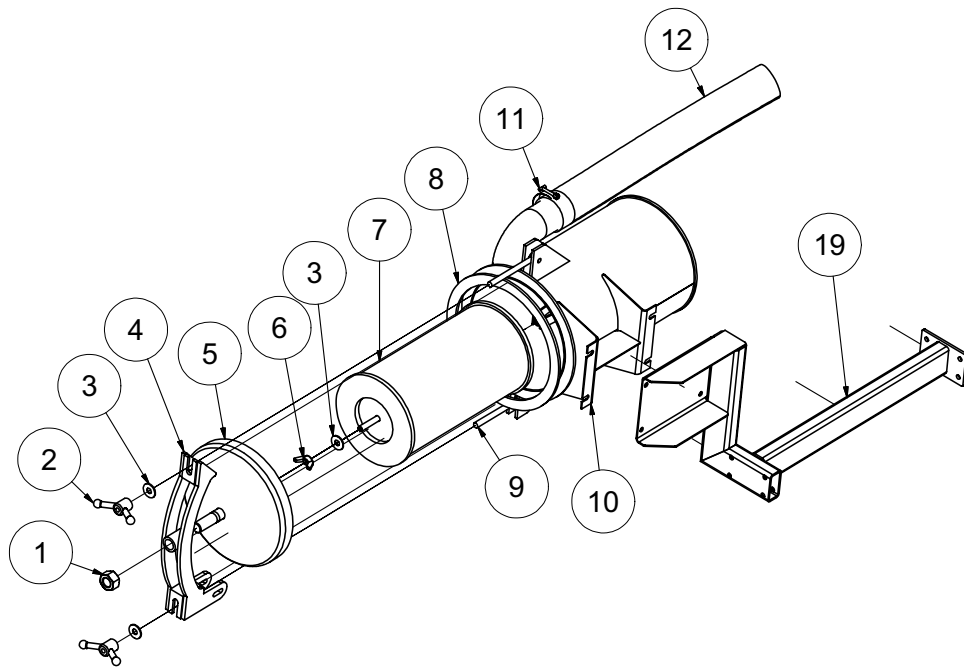
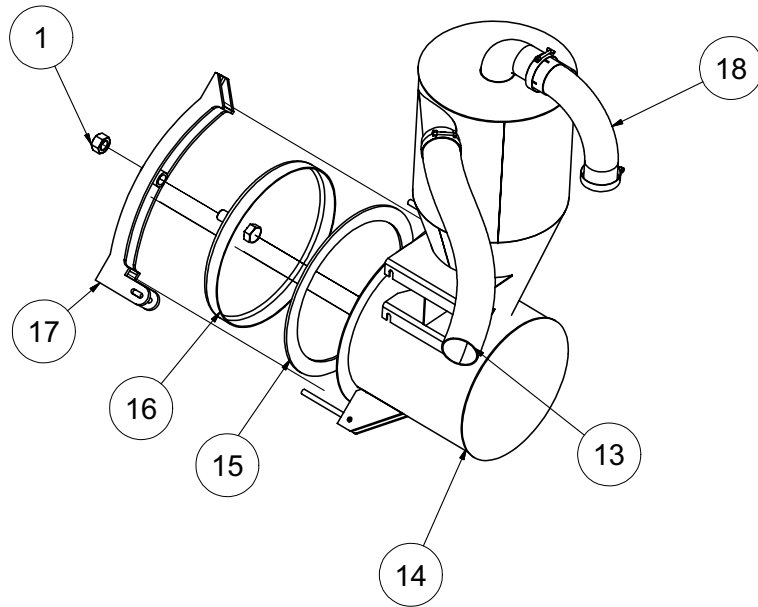

011112-E

VACASSY349

# Filtration

# 500/575

ITEM	QTY	PART #	DESCRIPTION
1	2	U120060	NUT, LOCK NY 1" - 8
2	4	8041594	Y - HANDLE
3	5	U200100	WASHER, FLAT 1/2"
4	1	8044622	DOOR LATCH (AIR FILTER) WELDMENT
5	1	8044620	575RF AIR FILTER DOME
6	1	8041219	NUT, WING 1/2-13
7	1	8031178	FILTER, ELEMENT 575 CFM
8	1	8044819	GASKET, REV FLOW AIR FILTER 575
9	4	8041593	EYE BOLT
10	1	8046337	FILTER HSG AIR 575RF
*	1	U000580	SCREW, HC 3/8"-16 X 3.5"
*	1	U000520	SCREW, HC 3/8"-16 X 2.25"
*	10	U200060	WASHER, FLAT 3/8"
*	2	U210061	NYLON LOCKNUT 3/8-16
11	4	8042605	CLAMP T-BOLT 3" (350)
12	1	8041325	HOSE VAC KANAFLEX 3-185"
13	1	8046825	HOSE AG SUCTION 3-48"
14	1	8044589	CYCLONE 575 REV FLOW
*	1	U000580	SCREW, HC 3/8"-16 X 3.5"
*	1	U000520	SCREW, HC 3/8"-16 X 2.25"
*	10	U200060	WASHER, FLAT 3/8"
*	2	U210061	NYLON LOCKNUT 3/8"-16
*	8	U000420	SCREW, HC 3/8"-16 X 1.00"
*	16	U200060	WASHER, FLAT 3/8"
*	8	U210061	NYLON LOCKNUT 3/8"-16
15	1	8041612	GASKET, REV FLOW CYCLONE
16	1	8041402	HD CYCLONE DOME DOOR ASSY
17	1	8041552	DOOR LATCH (CYCLONE WELDMENT)
18	1	8040682	3IN ELBOW 90 8IN LEG
19	1	8046243	AIR FILTER BRACKET LE
*	4	U000420	SCREW, HC 3/8"-16 X 1.00"
*	8	U200060	WASHER, FLAT 3/8"
*	4	U210061	NYLON LOCKNUT 3/8"-16

\* NOT SHOWN

011112-E

VACASSY349

# Engine Briggs & Stratton 31HP

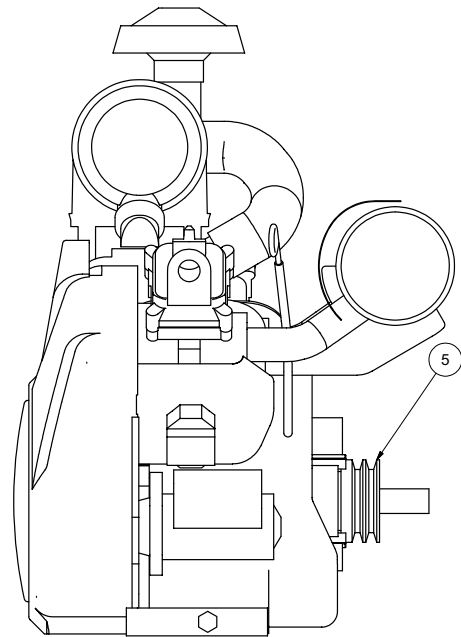
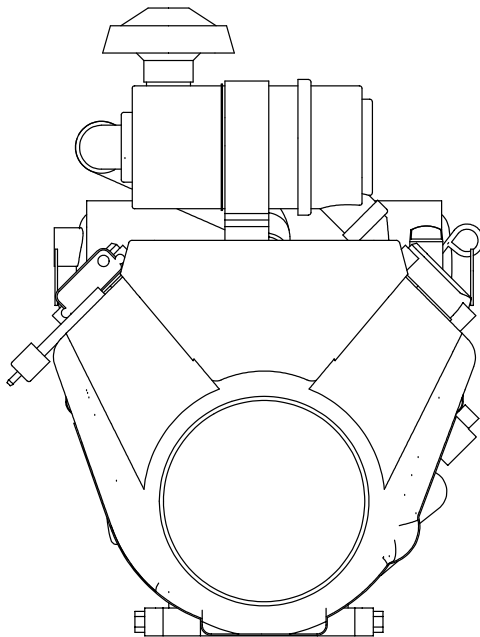
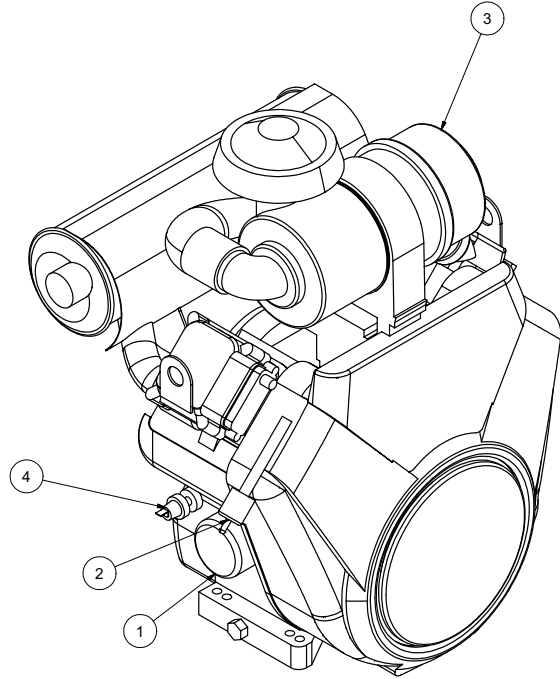

050809

VACASSY858

# Engine Briggs & Stratton 31HP

ITEM	QTY	NUMBER	DESCRIPTION
1	1	8045038-1	OIL FILTER
2	1	8045038-2	FUEL FILTER
3	1	8045038-3	AIR FILTER
4	1	8045038-4	OIL PRESURE SWITCH
5	1	8040695	SHEAVE, 6.55"OD SD 3-GROOVE
	1	8040696	BUSHING, 1 1/8" SD
*	1	8045321	KEY SET
*	1	8045322	SPARK PLUG

\* NOT SHOWN

# Blower Assembly

# 31LEG

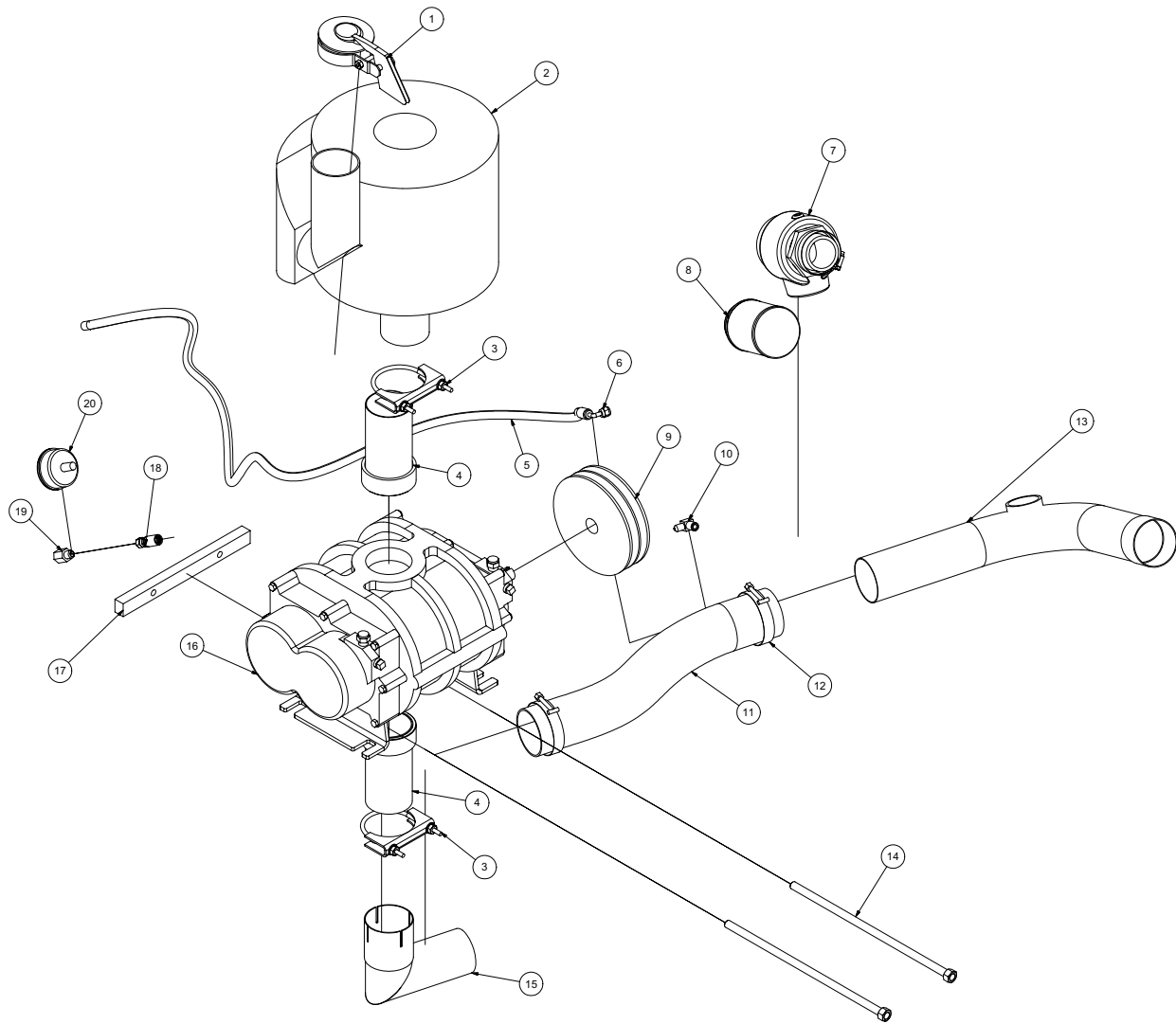

041414-E

VACASSY226



# Blower Assembly

# 31LEG

ITEM	QTY	PART NO.	DESCRIPTION
1	1	8044537	3" RAIN CAP SILENT
2	1	8030332	SILENCER, 500 CFM, COWL
3	2	8030395	3" U-BOLT CLAMP
4	2	8047478	UNION EXHAUST 3" OD-MNPT
5	1	8045254	HOSE VAC ASSY 4-55 ST-90
6	1	T320150	FITTING HOSE 4HO-4FJ 90
7	1	8030337	VALVE,2" AIR RELIEF SET 15"HG (STANDARD)
	1	8090946	VALVE,2" AIR RELIEF SET 13"HG (HIGH ALTITUDE)
8	1	8040340	KUNKLE VALVE FILTER
9	1	8040484	SHEAVE, 6.95" OD SDS 2-GROOVE
	1	8040696	BUSHING, 1 1/8" SD
	1	8041797	RETAINER
	2	8045217	BX50
10	1	T401100	ELBOW, 4MP-4MJ 90
11	1	8045255	HOSE VAC KANAFLEX 3-22
12	2	8042605	CLAMP T-BOLT 3" (350)
13	1	8044123	INLET ELBOW 31LEG
14	2	8040751	ROD TIGHTENER WELDMENT
15	1	8045637	EXHAUST 3" ELBOW TIGHT 90 ID-OD WELDMENT
16	1	8041250	BLOWER (MODEL47)
	4	U000817	SCREW, HC 1/2"-13 X 1"
	4	U210100	WASHER, LOCK 1/2"
	4	U200100	WASHER, FLAT 1/2"
17	1	8040702	TENSION BLOCK 575CFM
18	1	T320030	FITTING, HOSE 4HO-4FJ
19	1	T400110	UNION 4FP-4MJ
20	1	8041074	PRESSURE GAUGE

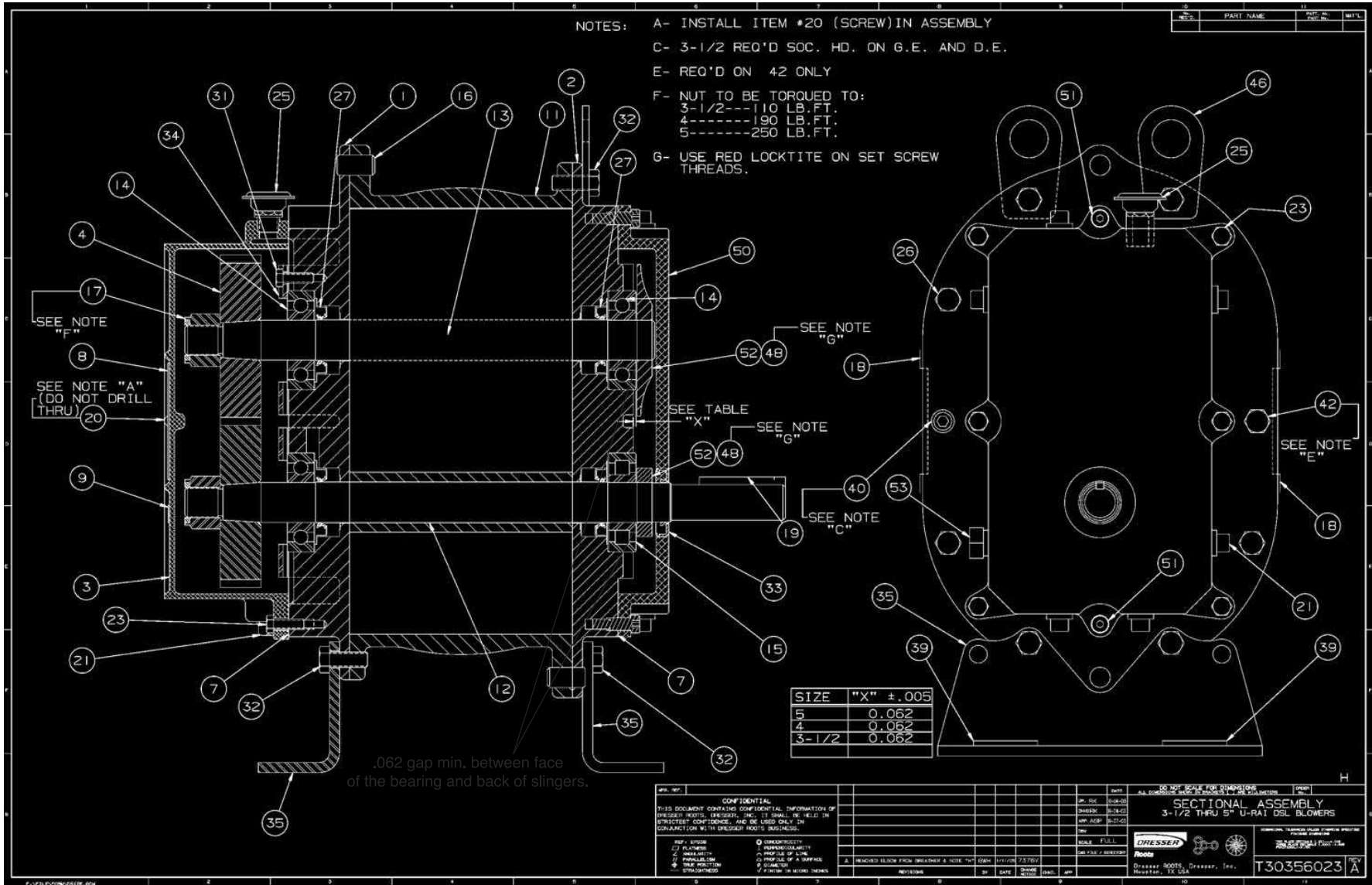

Assembly of URAI DSL Blowers with Splash Lubricated Drive End 3-5" Gear Diameter

**URAI-DSL Splash Lubricated Blowers  
4" Gear Diameter**

<b>Item #</b>	<b>Qty</b>	<b>Part #</b>	<b>Description</b>
1	1	8041250-1	Headplate Gear End
2	1	8041250-2	Headplate Drive End
3	1	8041250-3	Gearbox
4	2	8041250-4	Timing Gears
7	1	8041250-7	Gasket, Gear Box, DE Cover
11	1	8041250-11	Cylinder
12	1	8041250-12	Impeller & Shaft Drive
13	1	8041250-13	Impeller & shaft Driven
14	3	8041250-14	Bearing, Ball
15	1	8041250-15	Bearing, Roller
16	4	8041250-16	Pin, Dowel
17	2	8041250-17	Gear Nut
19	1	8041250-19	Key
21	3	8041250-21	Plug, Pipe
23	6	8041250-23	Screw Hex
25	1	8041250-25	Breather (Plug Vent)
26	*	8041250-26	Screw, Hex
27	4	8041250-27	Seal, Lip Bearing
31	4	8041250-31	Screw, Hex, Nylock
32	6	8041250-32	Screw, Hex
33	1	8041250-33	Seal Lip-Drive
34	2	8041250-34	Clamp Plate
35	2	8041250-35	Foot
39	4	8041250-39	Washer Mounting
40	2	8041250-40	Screw Socket
42	2	8041250-42	Screw Hex
48	4	8041250-48	DE Oil Slinger Set Screw
50	1	8041250-50	Drive End Cover
52	2	8041250-52	Drive End Oil Slinger
53	2	8041250-53	Oil Sight Glass

\*Quantities vary by blower.

# Water Pump Assembly

# TX1510 LEG

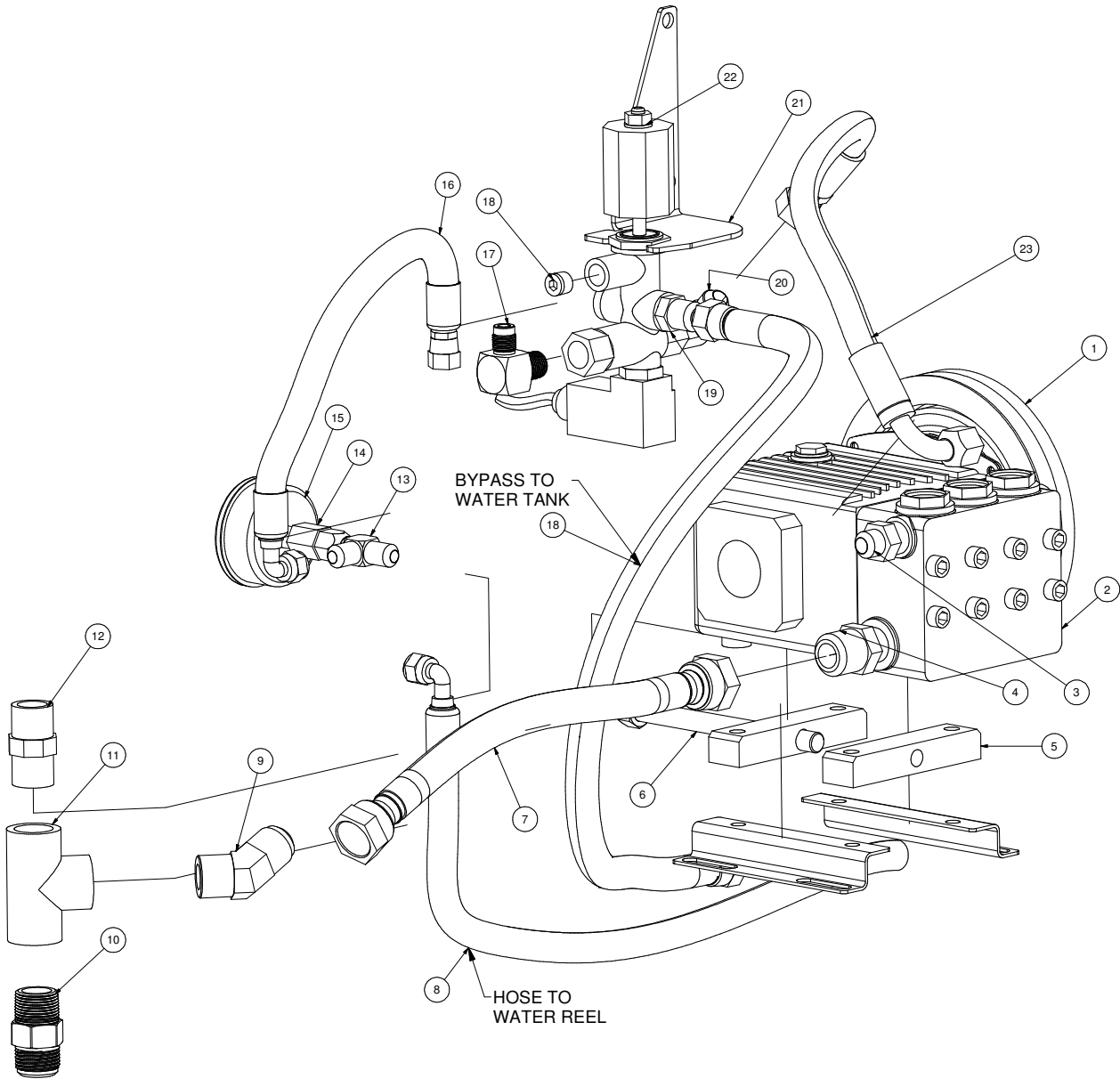

040114

VACASSY308

# Water Pump Assembly

# TX1510 LEG

ITEM	QTY	PART NO.	DESCRIPTION
1	1	8040176	SHEAVE, TX1512/10 CLUTCH
	1	8041803	BELT, AX47
2	1	8040834	PUMP, WATER TX1510 S34
3	1	T400028	UNION, 3/8MP - 3/8MJ
4	1	T400070	UNION, 1/2MP - 3/4MJIC
5	2	8040219	WATER PUMP ADJ BLOCK
6	1	8030020	ROD, TENSIONER WELDMENT
7	1	8045264	HOSE VAC PUSH 12-12
	2	8030525	FITTING, HOSE #12FJ PUSHLOCK
8	1	8090955	HOSE ASSY VAC 6-184"LG 90-90
9	1	8031252	ELBOW,45 12MP - 12MJ
10	1	T400100	UNION, 12MP-12MJ
11	1	T402160	TEE, 3/4"FP - 3/4"FP - 3/4"FP
12	1	T400800	UNION, 3/4"MP - 3/4"MP
13	1	T402153	TEE, 6MJ - 6MJ - 6FJ
14	1	8031126	REDUCER, 1/4"FP - 3/8" MJ
15	1	8030372	WATER PRESSURE GAUGE 1/4"NPT
16	1	8090956	HOSE ASSY VAC 6 - 15"LG ST-90
17	1	T401102	ELBOW,90 3/8"MP - 3/8" MJ
18	1	T405035	PLUG, 1/4"MP, SOCKET
19	1	T400030	REDUCER, 3/8"MP - 1/2" MJ
20	1	T401120	ELBOW, 90 3/8"MP - 1/2" MJ
21	1	8090903	BRACKET, UNLOADER (LEG)
22	1	8048979	VALVE, UNLOADER W/SWITCH
23	1	8049047	HOSE ASSY VAC 8 - 11 1/2"LG ST-90

040114

VACASSY308

# Water Pump TX1510

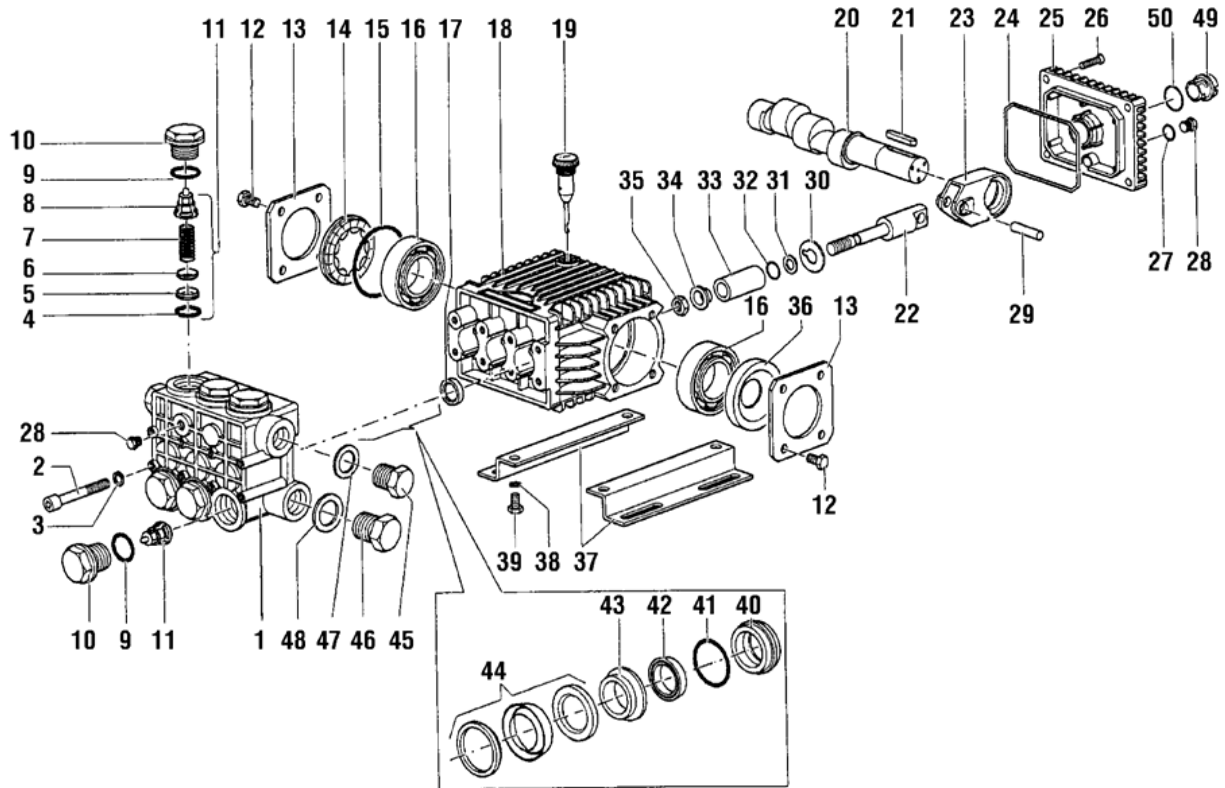

## TORQUE SPECS\*

\*Decrease torque by 20%  
if threads are lubricated

Pos.	Ft/lb	Nm
2	14.7	20
10	73.7	100
12	7.3	10
26	7.3	10
28	14.7	20
35	11.0	15
39	14.7	2
45	29.4	40
46	29.4	40

050409

VACASSY327

# Water Pump TX1510

ITEM	QTY.	PART #	DESCRIPTION	KIT #	ITEM #'S INCL'D IN KIT	NO. OF ASSY IN KIT	NO. OF CYL KIT WILL SERVICE
1	1	8040834-1	MANIFOLD, 15mm	8040834-KIT123	4,5,6,7,8,(11)	6	3
2	8	8040834-2	SCREW, M8 X 65	8040834-KIT124	9,10	6	3
3	8	8040834-3	LOCKWASHER, M8.4	8040834-KIT159	17	3	3
4	6	8040834-4	O-RING	8040834-KIT160	42,44	3	3
5	6	8040834-5	VALVE SEAT	8040834-KIT161	42,44	3	3
6	6	8040834-6	VALVE PLATE	8040834-KIT162	40	3	3
7	6	8040834-7	SPRING	8040834-KIT163	40	3	3
8	6	8040834-8	VALVE CAGE	8040834-KIT164	43	3	3
9	6	8040834-9	O-RING	8040834-KIT165	43	3	3
10	6	8040834-10	VALVE CAP	8040834-KIT166	40,41,42,43,44	1	1
11	6	8040834-11	VALVE ASSEMBLY	8040834-KIT167	40,41,42,43,44	1	1
12	8	8040834-12	SCREW, M6 X 10				
13	2	8040834-13	BEARING COVER				
14	1	8040834-14	OIL LEVEL INDICATOR				
15	1	8040834-15	O-RING				
16	2	8040834-16	BALL BEARING				
17	3	8040834-17	OIL SEAL				
18	1	8040834-18	CRANKCASE				
19	1	8040834-19	OIL DIP STICK				
20	1	8040834-20	CRANKSHAFT 10mm				
21	1	8040834-21	KEY				
22	3	8040834-22	PLUNGER GUIDE				
23	3	8040834-23	CONNECTING ROD				
24	1	8040834-24	O-RING COVER				
25	1	8040834-25	REAR CRANKCASE COVER				
26	4	8040834-26	SCREW, M6 X 14				
27	1	8040834-27	O-RING				
28	2	8040834-28	PLUG, 1/4"G				
29	3	8040834-29	CONNECTING ROD PIN				
30	3	8040834-30	FLINGER WASHER				
31	3	8040834-31	ANTI-EXTRUSION RING				
32	3	8040834-32	O-RING				
33	3	8040834-33	CERAMIC PLUNGER				
34	3	8040834-34	BUSHING				
35	3	8040834-35	NUT, M8				
36	1	8040834-36	OIL SEAL				
37	2	8040834-37	RAIL				
38	4	8040834-38	LOCK WASHER, M8				
39	4	8040834-39	SCREW, M8 X 16				
40	3	8040834-40	SEAL RETN'R 15mm				
41	3	8040834-41	O-RING				
42	3	8040834-42	SEAL, LP, 15mm				
43	3	8040834-43	INT. RING, 15mm				
44	3	8040834-44	PACKING ASSY, 15mm				
45	1	8040834-45	PLUG, 3/8"G				
46	1	8040834-46	PLUG, 1/2"G				
47	1	8040834-47	WASHER, M17.5				
48	1	8040834-48	WASHER, M21.5				
49	1	8040834-49	OIL LEVEL INDICATOR				
50	1	8040834-50	O-RING				

050409

VACASSY327

# Unloader Valve PULSAR4KHP

092413

VACASSY01305



# Unloader Valve PULSAR4KHP

ITEM	QTY	PART #	DESCRIPTION
1	1	8047993-1	PISTON HOLDER, BRASS
2	2	8047993-2	O-RING, 1.78 X 14MM
3	1	8047993-3	PISTON, SST
4	1	8047993-4	BACK-UP RING, OPN, 14 X 16 X 2MM
5	1	8047993-5	O-RING, 1.78 X 10.82MM
6	1	8047993-6	HOUSING, 3/8" NPT-F, BRASS
7	1	8047993-7	SEAT, 8MM + O-RING, 1.78MM
9	1	8047993-9	BALL, 13/32", SST
10	1	8047993-10	SPRING, 1.6 X 11.5 X 20MM, SST
11	1	8047993-11	INLET COUPLING, 3/8 NPT-F, BRASS
13	2	8047993-13	GRUB SCREW, 3/8N NPT
14	1	8047993-14	BACK-UP RING, OPN, 6.2 X 9 X 1.2MM
15	1	8047993-15	O-RING, 1.78 X 6.07MM
16	2	8047993-16	O-RING, 3 X 6MM
17	1	8047993-17	SHUTTER PIN, BRASS + O-RING 3 X 6MM
18	1	8047993-18	SPRING, 0.7 X 9 X 20 SST
19	1	8047993-19	O-RING, 1.78 X 15.6MM, NI
20	1	8047993-20	NIPPLE, 3/8 NPT-F
21	1	8047993-21	KNOB, 6 X 1
22	1	8047993-22	HEX, LOCKNUT, M8
24	1	8047993-24	KNOB + PLUG
25	1	8047993-25	WASHER, 9.2 X 24 X 0.5MM
26	2	8047993-26	HEX NUT, M8, BRASS
27	1	8047993-27	SPRING, 5 X 25 X 50MM, WHITE, PULSAR4KLP SPRING, 5 X 25 X 53MM, BLUE, PULSAR4KHP
30	1	8047993-30	SEAT FRAME

# Control Panel LEG-Series

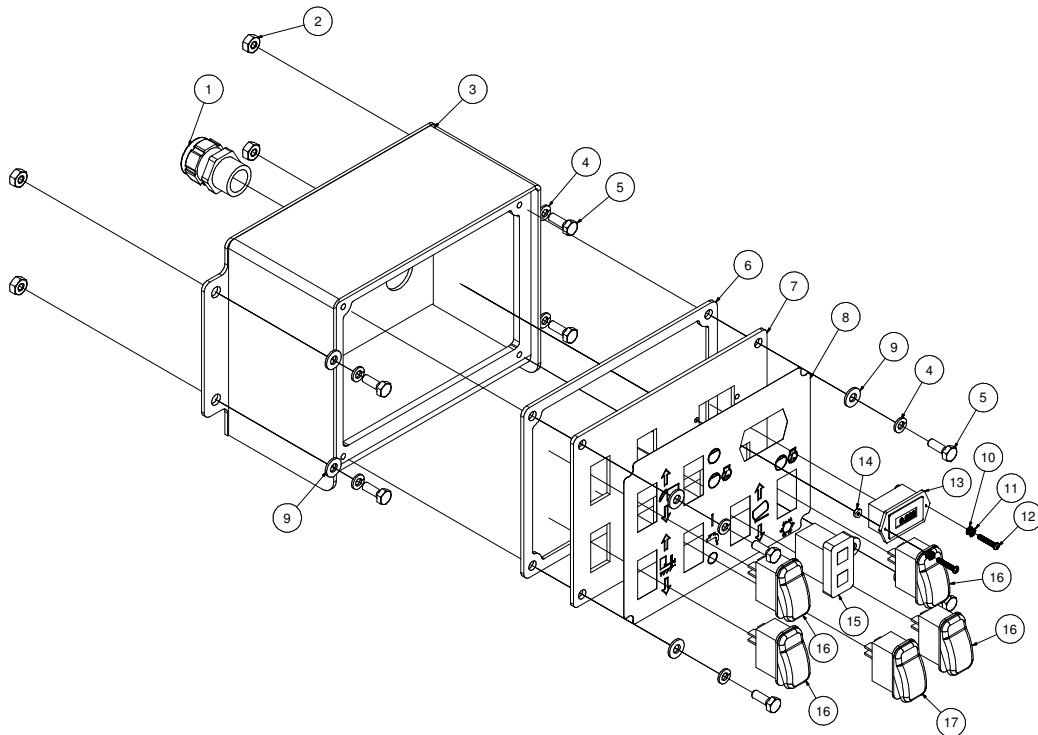
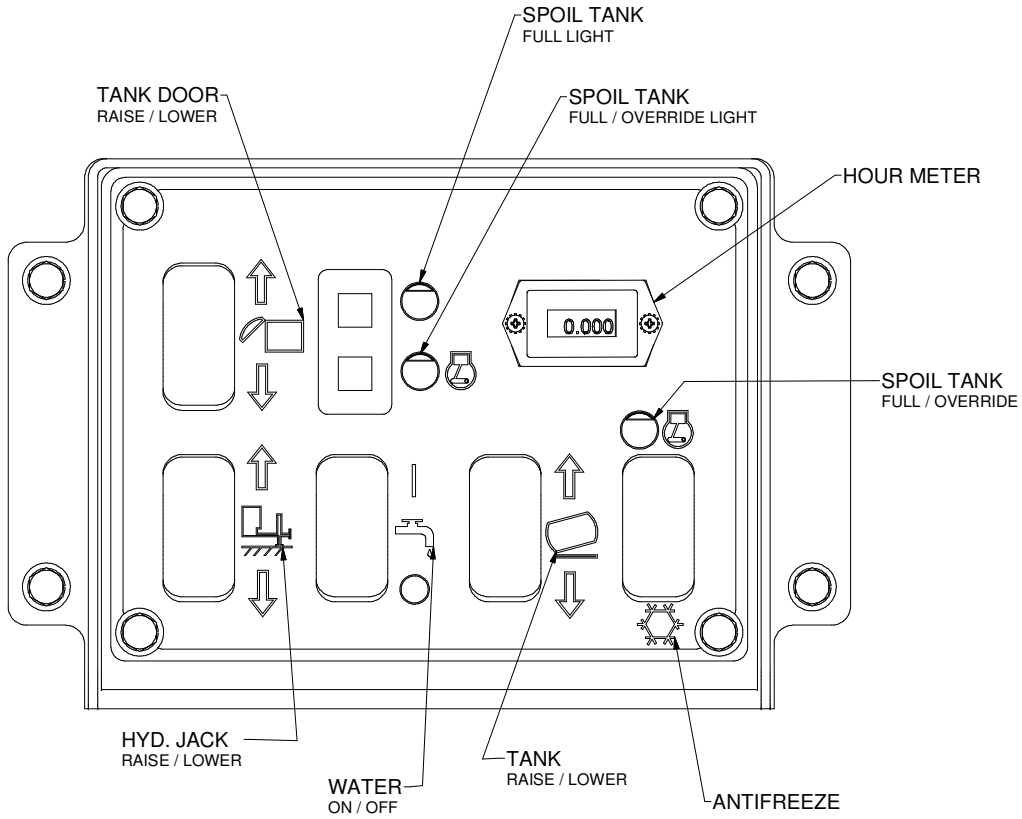

041713-E

VACASSY01506

# Control Panel LEG-Series

ITEM	QTY	PART NO.	DESCRIPTION
1	1	X000109	STRAIN RELIEF, 3/4"
2	4	U120100	NUT, LOCK 1/4"-20
3	1	8048631	LEG CONTROL BOX (LARGE)
4	8	U210020	WASHER, LOCK 1/4"
5	8	U000040	SCREW, HC 1/4"-20 X .750
6	1	8048627	COVER PLATE GASKET
7	1	8048626	COVER PLATE
8	1	J200635	DECAL, CONTROL PANEL LEG
9	8	U200020	WASHER, FLAT 1/4"
10	2	U210008	WASHER, LOCK #4 ZP INTERNAL
11	2	U210009	WASHER, LOCK #4 EXTERNAL TOOTH
12	2	U030502	SCREW, PAN HD PHIL #4-40 X .750
13	1	X000350	HOUR METER
14	2	U100004	NUT, HEX M/S #4-40
15	1	X000260	LIGHT, LED DUAL PANEL
16	4	X000274	SWITCH, ROCKER DPST (ON) OFF (ON)
17	1	X000270	SWITCH, ROCKER SPST ON - OFF

\* NOT SHOWN

# Hydraulic Pump

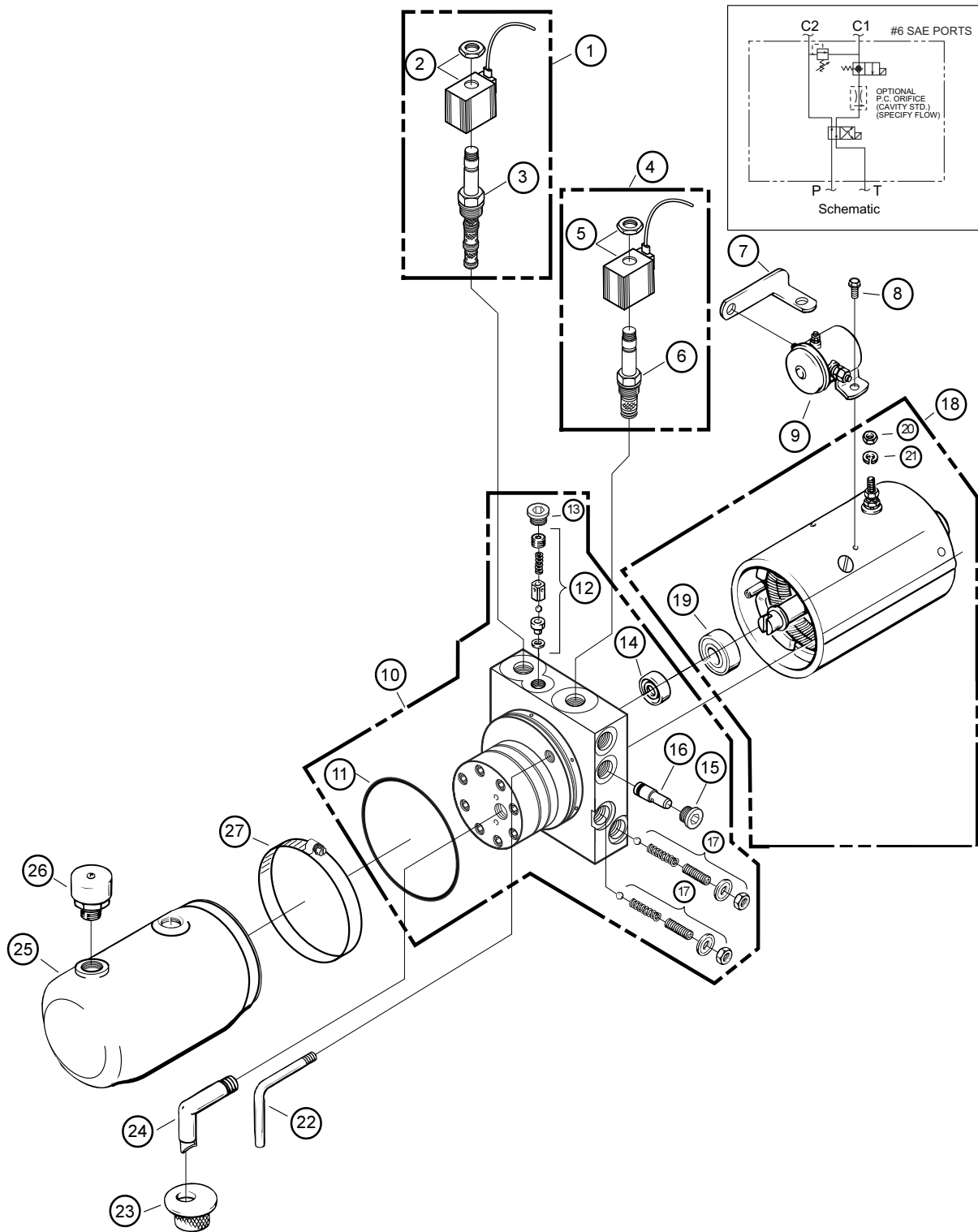

062409

VACASSY249

# Hydraulic Pump

ITEM	QTY	NUMBER	DESCRIPTION
	1	8041601	HYDRAULIC PUMP 12V 6QT
		8040486	HYDRAULIC PUMP 12V 3QT
	2	U000420	SCREW, HC 3/8"-16 X 1
	2	U210060	WASHER, LOCK 3/8"
	2	U200600	WASHER, FLAT 3/8"
	2	T400037	UNION 6MB-6MJR
	2	8040973	HOSE ASSY VAC 6-20 ST-90
	2	T400391	BULKHEAD 6MP 6MP
1	1	8041601-14	VALVE, 4 WAY - 2 POSITION (12V)
2	1	8041601-15	COIL, 10 VDC GROUNDED W/DEUTSCH CONN
3	1	8041601-16	CARTRIDGE, 4 WAY - 2 POSITION
4	1	8041601-17	VALVE, 2 WAY - 2 POSITION (12V) GROUNDED
5	1	8041601-18	COIL, 10 VDC, 2 WAY-2 POS GRND W/DEUTSCH CONN
6	1	8041601-19	VALVE 12V HYD 2 WAY-2 POS
7	1	8041601-20	STRAP, MOTOR SOLENOID CONNECTING
8	2	8041601-21	SCREW, RND HD MACH 10-32 X 1/4"
9	1	8041601-22	SWITCH, SOLENOID 12VDC, 3 POST GRND
10	1	8041601-23	PUMP ASSY
11	1	8041601-24	O-RING INDUST 3-5/8 X 3-7/8 X 1/8
12	1	8041601-25	PARTS KIT-VALVE ASSY, POPPET/BALL CHECK
13	1	8041601-26	PLUG
14	1	8041601-27	SEAL
15	1	8041601-28	PLUG, #8 SAE
16	1	8041601-29	VALVE, PRESS, COMP ORIFICE
17	2	8041601-30	PARTS KIT, RELIEF VALVE
18	1	8041601-31	MOTOR, ELECTRIC 12 VDC
19	1	8041601-32	BEARING, BASE, MOTOR
20	1	8041601-33	NUT, HEX 5/16-24
21	1	8041601-34	WASHER, LOCK 5/16"
	2	8041601-38	SCREW, HEX HEAD, 1/4-20 X 1-3/8"
	1	8041601-41	PLUG, 3/8" NPTF
22	1	8041601-42	TUBE, RETURN (1/8")
23	1	8041601-43	SCREEN, FILTER (SUCTION)
24	1	8041601-44	TUBE, FILTER SUCTION 3/8 NPT 90 DEG
25	1	8041601-45	6QT RESEVOIR POLY
	*	8040486-45	3QT RESEVOIR POLY
26	1	8041601-46	PLUG, VENT, 3/8" NPT
27	1	8041601-47	CLAMP, HOSE WORM GEAR (IN SERIES)
*	1	X200002	HYDRAULIC PUMP WIRE HARNESS

\* NOT SHOWN

# Water Tank Assembly

# 125 Gallon Saddle Tanks 31LEG/LE

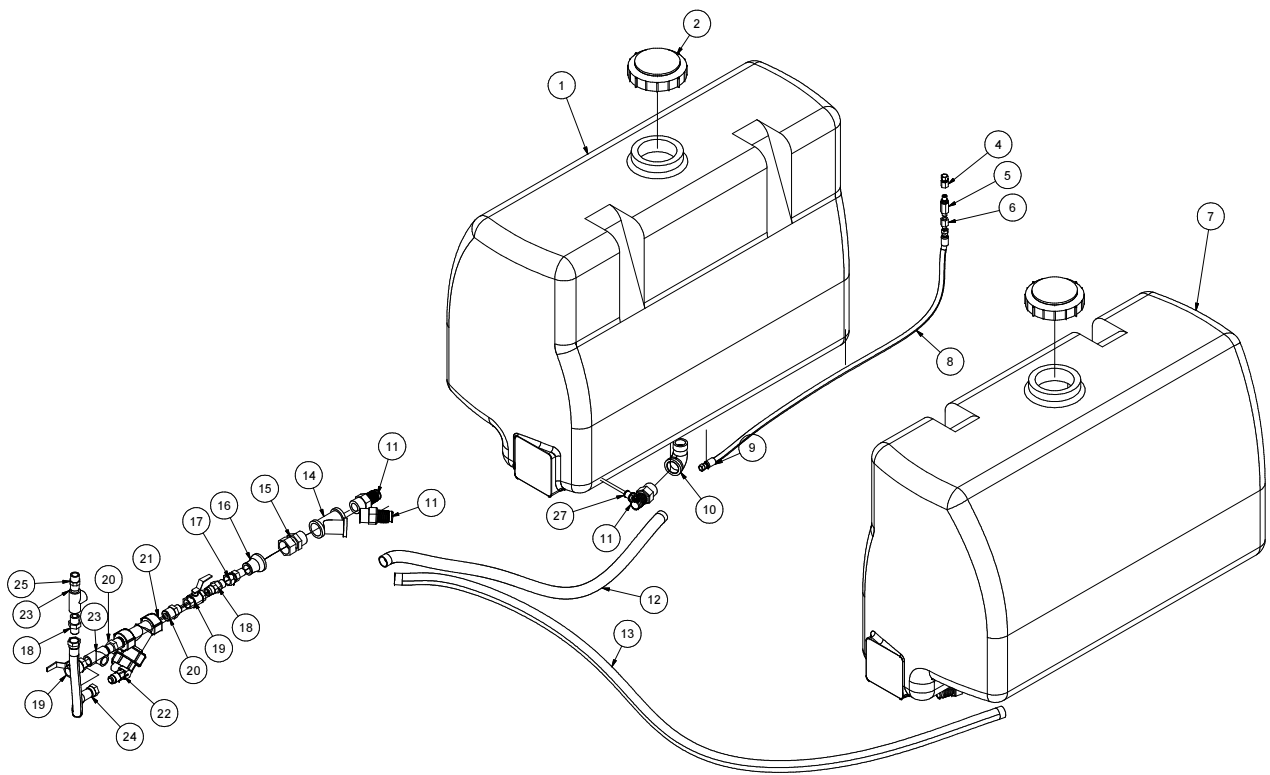

091914-E

VACASSY611

# Water Tank Assembly

# 125 Gallon Saddle Tanks 31LEG/LE

ITEM	QTY	NUMBER	DESCRIPTION
1	1	8040782-1	TANK, WATER SADDLE (125 GAL) CURB SIDE
2	2	8041119	LID, 125 GAL TANK
3	1	8030394	ANTI-FREEZE TANK 4GAL
4	1	8031125	UNION, 4FP - 6FJ
5	1	8030923	FILTER, WATER HIGH PRESSURE
6	1	8031126	UNION, 4FP - 6MJ
7	1	8040782	TANK, WATER SADDLE
8	1	8045262	HOSE ASSY VAC 6 - 125" ST-ST
9	2	T320040	FITTING, HOSE 6HO - 6FJ
10	2	T420120	STREET ELBOW 90 - 1 1/4"
11	4	8041312	FITTING, HOSE BARB 20HB - 20MP
12	1	8044637	HOSE VAC VINYL 1 1/4" - 30"
13	1	8045263	HOSE VAC VINYL 1 1/4" - 54"
14	1	8045201	WYE, 1 1/4"FP 45DEG BLACK PIPE
15	1	8045203	UNION, 1 1/4"MP - 1 1/4"FP SWIVL
16	1	8045202	COUPLING, PIPE 1 1/4" - 3/4"
17	1	T400101	UNION, 3/4"FJ - 3/4"MP
18	2	T400100	UNION, 12MP - 12MJ
19	3	T000185	VALVE, BALL 3/4" FNPT BRASS
20	2	T404060	UNION, 16MP - 12MP
21	1	8040186	STRAINER "Y" BANJO
	1	8040186-1	END CAP
	1	8040186-2	GASKET
	1	8040186-3	STRAINER PLUG
	1	8040186-4	FKM O-RING
	1	8040186-5	STRAINER MESH SCREEN 80
	1	8040186-6	Y-BODY
	1	8040186-7	EPDM O-RING
22	1	T401180	ELBOW, 90 3/4"MP - 3/4"MJ
23	2	T402160	TEE, 3/4"FP - 3/4"FP - 3/4"FP
24	1	8043688	HOSE VAC PUSH 12-20"
25	1	T400800	UNION, 12MP - 12MP
26	1	T403100	REDUCER, 20MP - 12FP
27	1	8090896	SWITCH, WATER TANK HORIZ

# Water Tank Assembly

# 50Gallon Saddle Tanks LE

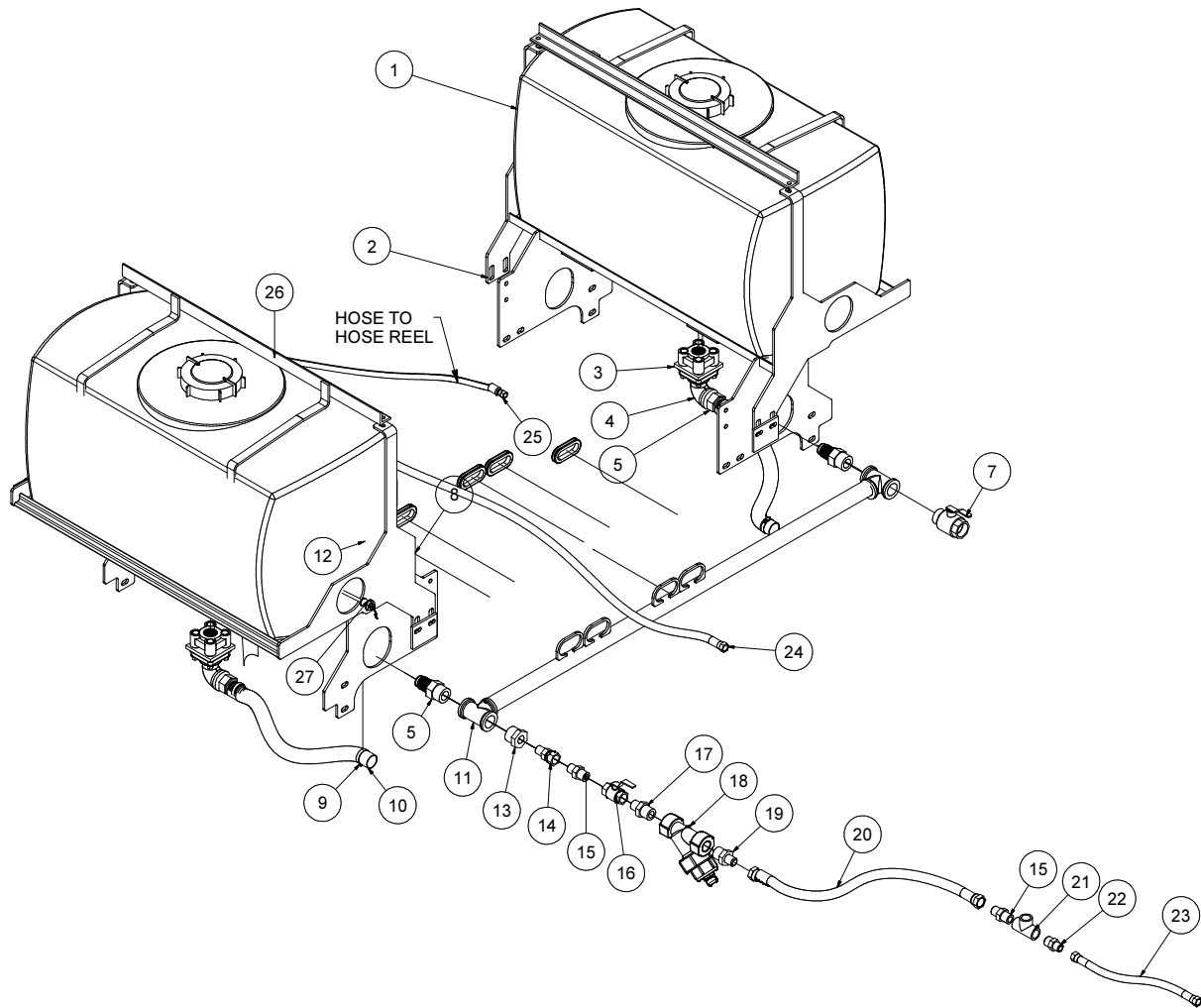

091814-E

VACASSY610



# Water Tank Assembly

# 50Gallon Saddle Tanks 31LE

ITEM	QTY	PART NO.	DESCRIPTION
1	2	8034151	50 GALLON WATER TANK
2	1	8045815	WATER TANK FRAME (STREET)
	1	8046631	WATER TANK HOLD DOWN
3	2	8045093	BULKHEAD, 1 1/4" BOTTOM DRAIN BANJO
4	2	8041311	ELBOW, 90 1 1/4" STREET GALVAN
5	4	8041312	FITTING, 1 1/4"MP - 1 1/4"HB
6	2	T405065	PLUG #12MP
7	1	8045813	VALVE, BALL 1 1/4" M x F BRASS
8	1	8045816	WATER TANK FRAME (CURB)
	1	8046631	WATER TANK HOLD DOWN
9	4	8040677	CLAMP, HOSE 1 1/4" - 2 1/8" HD
10	2	8041523	HOSE VAC CLEAR VINYL 1 1/4" - 24"
11	1	8045810	WATER HEADER LE
12	5	8042812	GROMMET 2" ID X 3" OD X 1 1/4"WOG
13	1	T403100	REDUCER, 1 1/4"MP - 3/4"FP
14	1	T400101	UNION, 3/4"FJ - 3/4"MP
15	2	T400100	UNION, 3/4"MP - 3/4"MJ
16	1	T000185	VALVE, BALL 3/4" FNPT BRASS
17	1	T404060	REDUCER, 1"MP - 3/4"MP
18	1	8040186	STRAINER, Y 1" BANJO
	1	8040186-1	END CAP
	1	8040186-2	GASKET
	1	8040186-3	STRAINER PLUG
	1	8040186-4	FKM-O-RING
	1	8040186-5	STRAINER MESH SCREEN 80
	1	8040186-6	Y-BODY
	1	8040186-7	EPMD O-RING
19	1	T400450	REDUCER 1"MP - 3/4"MJ
20	1	8044638	HOSE VAC PUSH 12 - 40"
21	1	T402160	TEE, 3/4"FP - 3/4"FP - 3/4"FP
22	1	T400080	REDUCER, 12MP - 8MJ
23	1	8041322	HOSE VAC PUSH 8 - 20"
24	1	8041059	HOSE VAC PUSH 8 - 66"
25	1	8041476	HOSE ASSY VAC 6 - 150" ST-90
26	1	8030518	ELBOW, 45 1/2" MJ BULKHEAD
27	1	8090896	SWITCH, WATER TANK HORIZ

# Antifreeze Assembly

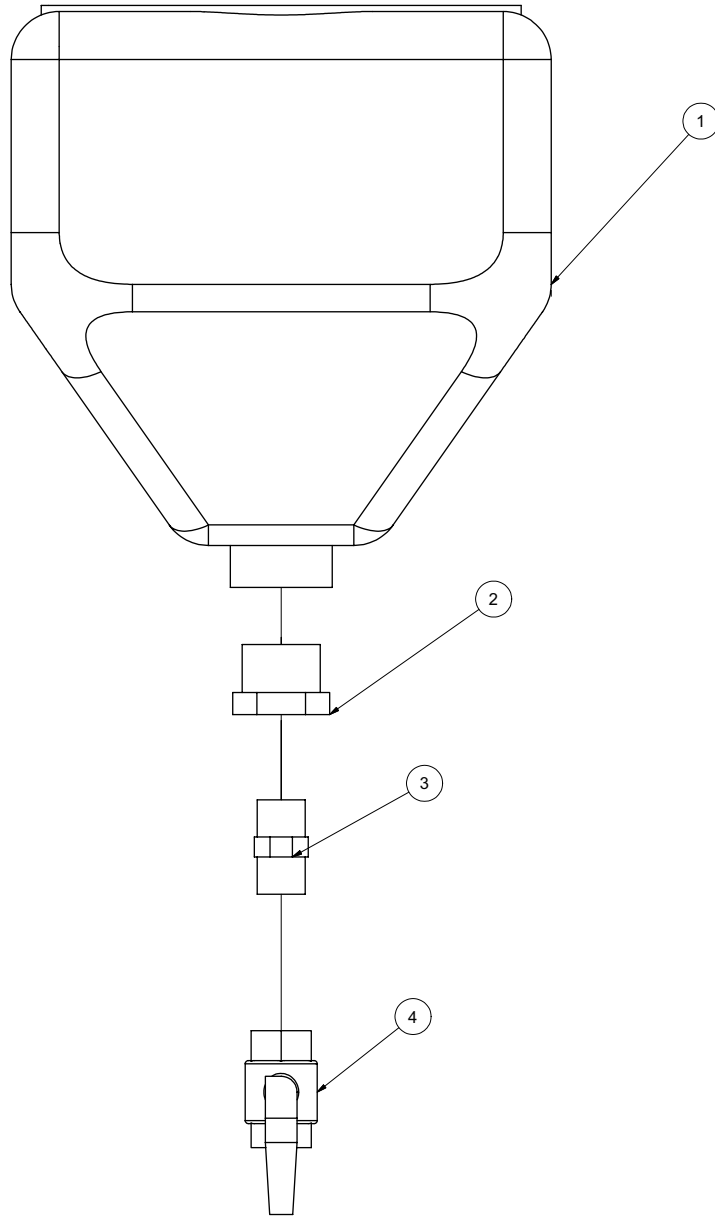

060309

VACASSY943

# Antifreeze Assembly

ITEM	QTY	PART NO.	DESCRIPTION
1	1	8030394	ANTI-FREEZE TANK 4 GAL.
	4	U000180	SCREW, HC .312 -18 X .750
	4	U200040	WASHER, FLAT 5/16"
	4	U210040	WASHER, LOCK 5/16"
2	1	T400585	REDUCER, 20MP-12FP
3	1	T400800	UNION, 12MP-12MP
4	1	T000185	BALL VALVE, BRASS 3/4" FP

060309

VACASSY943

# Hose Reel Assembly

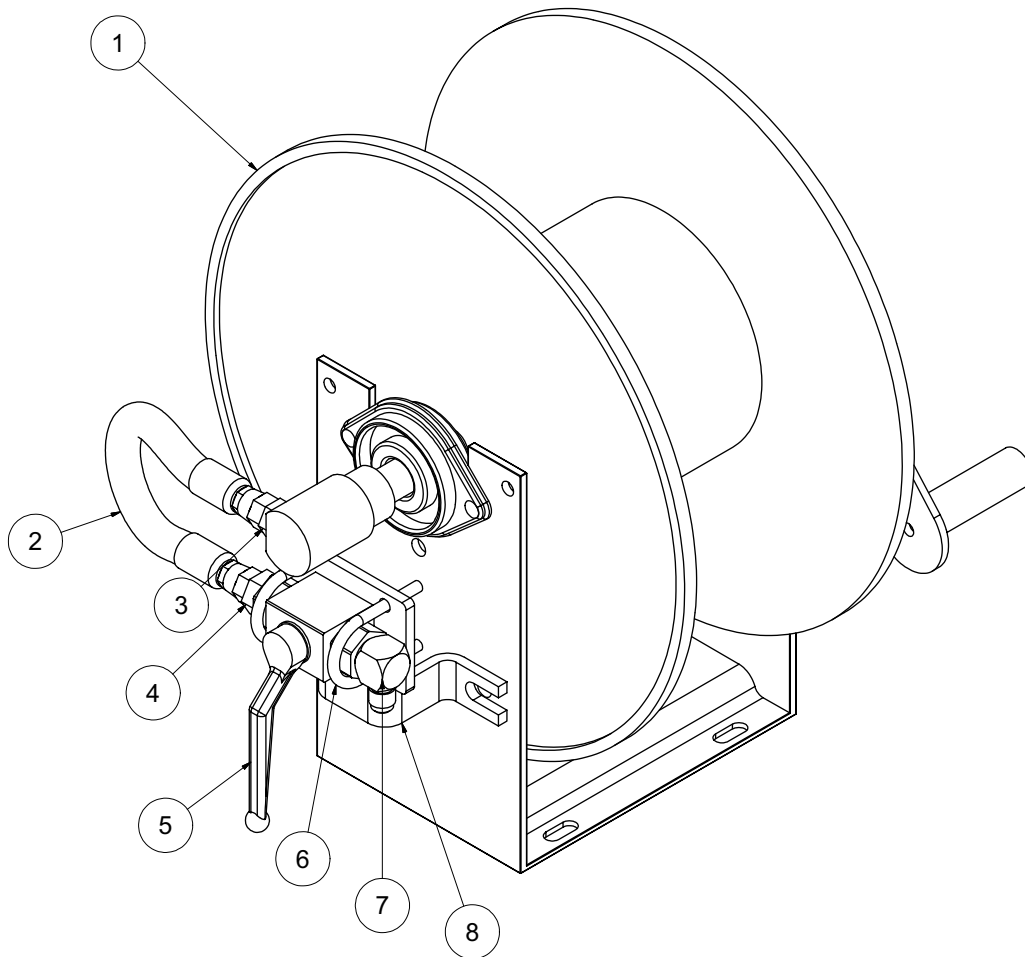

101112-E

VACASSY762

# Hose Reel Assembly

ITEM	QTY	NUMBER	DESCRIPTION
1	1	8030879	HOSE REEL, WATER 3/8" X 100
2	1	8044147	HOSE ASSY VAC 6-10 ST-ST
	2	T320040	FITTING, HOSE 6HO-6FJ
3	1	8031291	UNION, 1/2"MP - 3/8"MJ
4	1	T400028	UNION, 3/8"MP - 3/8"MJ
5	1	8030351	STEEL BALL VALVE - 3/8"NPT
6	2	U010017	1 1/2" CLAMP HOOK 1/4 - 20 THD
7	1	T401102	ELBOW 6MJ - 6MP
8	1	8046740	BALL VALVE BRACKET
*	1	8041830	HOSE ASSY 3/8" X 50' 4000PSI
*	1	8030504	REDUCER, 3/8" FP - 1/4"MP
*	1	8030526	FITTING, QD WATER 1/4"FJ - 1/4"FP SS

101112-E

VACASSY762

# Hose Reel (Components)

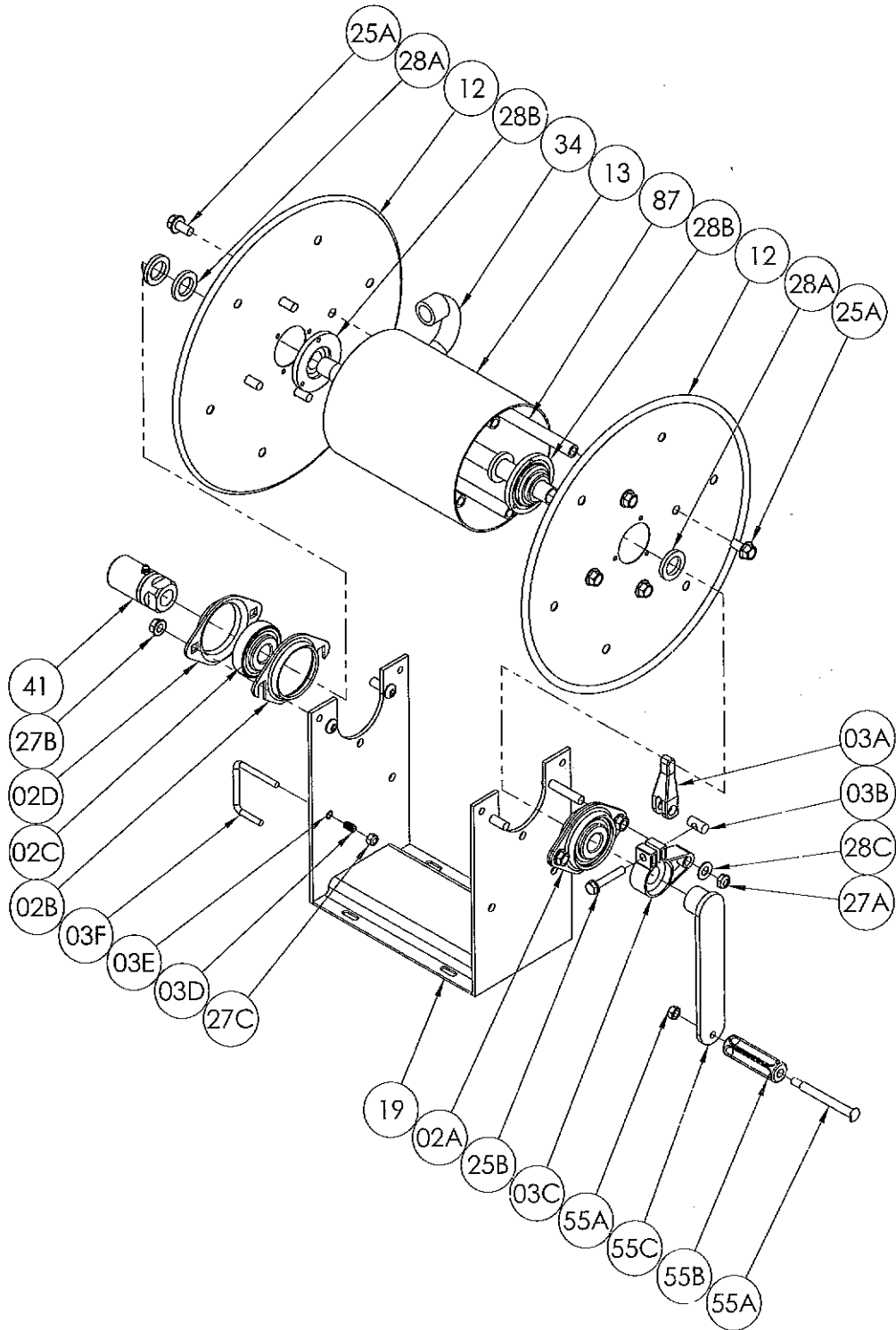

072210-E

VACASSY761

# Hose Reel Assembly

ITEM	QTY	NUMBER	DESCRIPTION
	1	8030879	HOSE REEL, WATER 3/8" X 100
1	2	8030879-02A	1/2" SELF ALIGNING BEARING for 1000 SERIES (INCLUDES 02B, 02C and 02D)
2	2	8030879-02B	SELF ALIGNING BEARING HOLDER SLOTTED
3	2	8030879-02C	1/2" SELF ALIGNING BEARING INSERT
4	2	8030879-02D	SELF ALIGNING BEARING HOLDER
5	1	8030879-03A	CAM LOCK LEVER
6	1	8030879-03B	BRASS BARREL NUT for CAM LOCK BRAKE
7	1	8030879-03C	CAM LOCK DRAG BRAKE BODY for 1/2" HUBS
8	1	8030879-03D	SPRING for PL-3 PINLOCK (1" LONG X 0.32"OD X 0.26"ID)
9	1	8030879-03E	PINLOCK MOUNTING SLEEVE (NOT FIELD INSTALLABLE)
10	1	8030879-03F	PL-3 PINLOCK
11	1	8030879-03G	CAM LOCK KIT (INCLUDES 03A, 03B, 03C and 25B)
12	1	8030879-03H	PL-3 PINLOCK KIT (INCLUDES 03D, 03E, 03F and 27C)
13	2	8030879-12	(14-16) 14.25" DIAMETER DISC 18GA STEEL - SPECIFY MODEL
14	1	8030879-13	DRUM, 6" DIAMETER ALUMINUM - SPECIFY MODEL
15	1	8030879-19	STEEL FRAME ASSY. FOR 1000 SERIES REEL - SPECIFY MODEL
16	8	8030879-25A	3/8"-16 X 3/4" SPINLOCK BOLT
17	1	8030879-25B	5/16" -18 X 1 3/4" HEX HEAD BOLT w/ NYLOCK PATCH
18	1	8030879-27A	3/8" - 16 HEX HEAD NUT (ESNA)
19	4	8030879-27B	3/8"- 16 SPINLOCK NUT
20	1	8030879-27C	1/4"-20 HEX HEAD HUT (ESNA)
21	3	8030879-28A	1 3/8"OD X 7/8"ID X 3/16" HUB SPACER WASHER
22	2	8030879-28B	1/2" HUB DISC WASHER, per P28A-00050
23	1	8030879-28C	3/8" SAE FLAT WASHER (13/16"OD)
24	1	8030879-34	1/2" WELDED STEEL HUB - SPECIFY MODEL and OUTLET FITTING
25	1	8030879-41	1/2" 90 DEGREE F x F SUPER SWIVEL (AFLAS PACKING)
26	1	8030879-55A	3/8" SHOULDER BOLT and NUT for plastic crank handle
27	1	8030879-55B	BLACK PLASTIC CRANK HANDLE
28	1	8030879-55C	HAND CRANK (INCLUDES 55A and 55B)
29	4	8030879-87	ANODIZED ALUMINUM THREADED SPACER TUBE

072210-E

VACASSY761

# Hose Reel Assembly

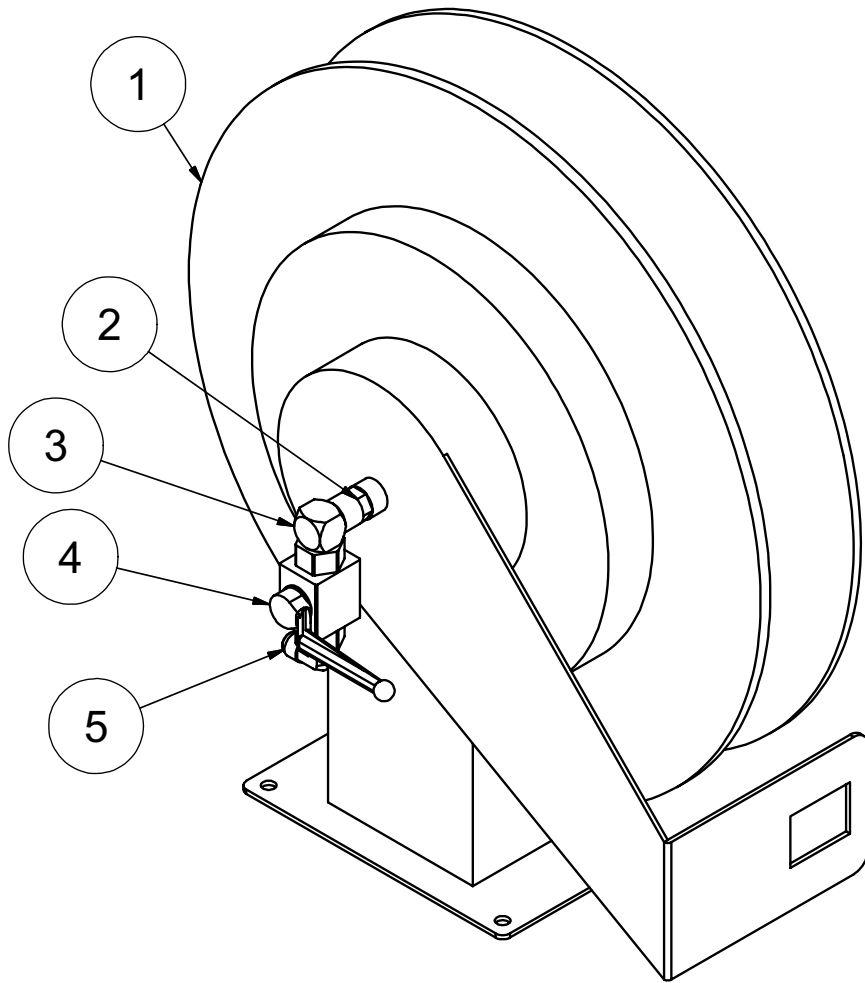

081010-E

VACASSY763



# Hose Reel Assembly

ITEM	QTY	NUMBER	DESCRIPTION
1	1	8031240	REEL with HOSE SPRINGDRIVEN 3/8" X 50'
2	1	8031269	UNION, 1/2"MP - 3/8"MP
3	1	T401065	ELBOW, 3/8"MP - 3/8"FP
4	1	8030351	STEEL BALL VALVE - 3/8"NPT
5	1	8030498	ELBOW, 3/8"MP - 3/8"MJ 90

081010-E

VACASSY763

# Hose Reel

# Components

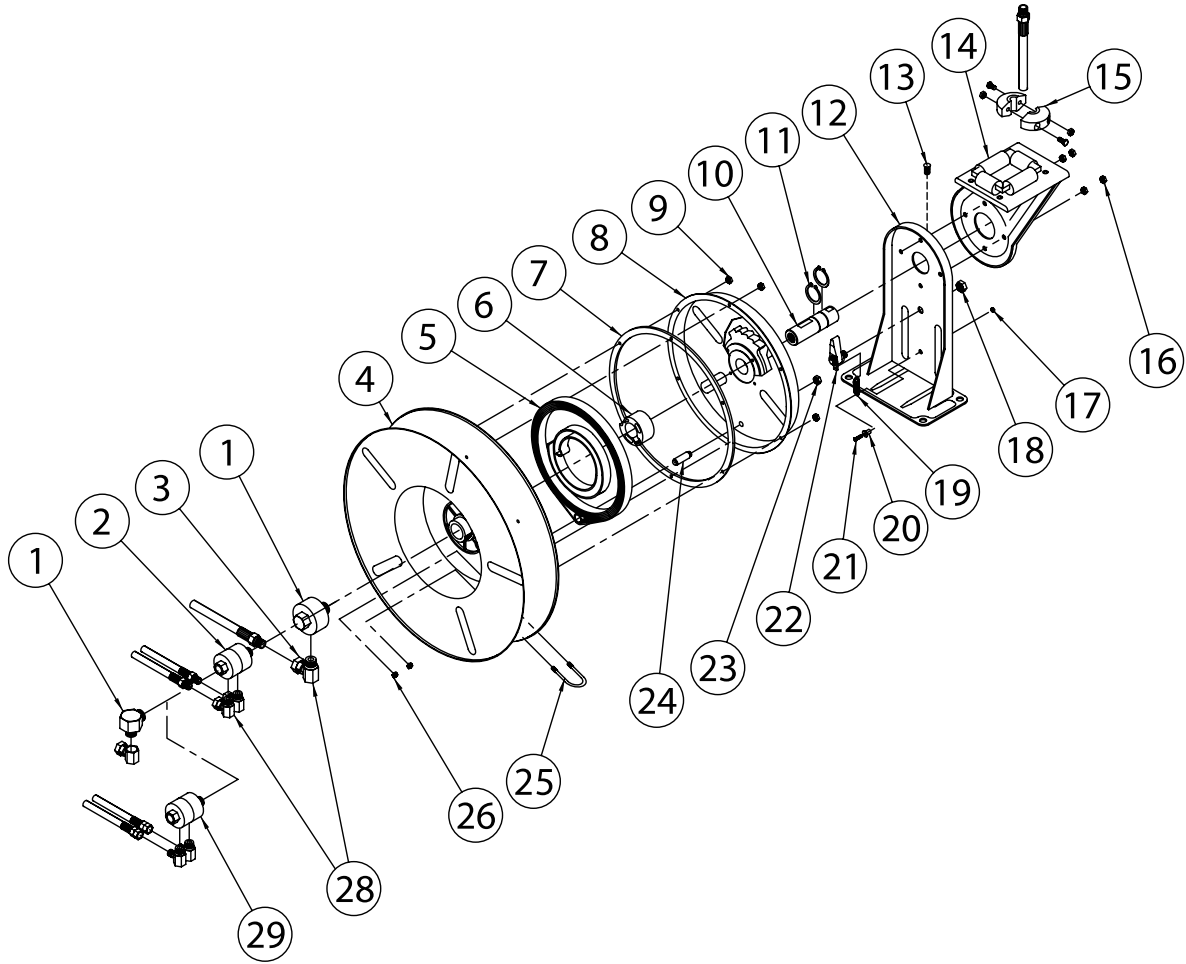

081010-E

VACASSY764

# Hose Reel

# Components

ITEM	QTY	NUMBER	DESCRIPTION
		8031240	REEL with HOSE SPRINGDRIVEN 3/8" X 50'
1	1	8031240-1	SWIVELASSEMBLY
2	1	8031240-2	SWIVEL & ELLASSEMBLY
3	1	8031240-3	90 DEG ELL
4	1	8031240-4	SHEAVEASSEMBLY
5	1	8031240-5	DRIVE SPRINGASSEMBLY
6	1	8031240-6	SPRING ARBORASSEMBLY
7	1	8031240-7	GASKET
8	1	8031240-8	SPRING CASE ASSEMBLY
9	6	8031240-9	10-32 HEX LOCKNUT
10	1	8031240-10	MAIN SHAFT
11	2	8031240-11	1 1/4" SNAP RING
12	1	8031240-12	BASE ASSEMBLY
13	1	8031240-13	1/2"-13 SET SCREW
14	1	8031240-14	GUIDE ARM W/ ROLLERS
15	1	8031240-15	HOSE BUMPERASSEMBLY
16	4	8031240-16	5/16"-18 LOCKNUT
17	1	8031240-17	10-32 X 3/8" NYLOCK NUT
18	1	8031240-18	1/2"-20 X 5/8" HEX NUT
19	1	8031240-19	LATCH SPRING
20	1	8031240-20	BUSHING
21	1	8031240-21	10-32 X 7/8" SCREW
22	1	8031240-22	LATCH PAWLASSEMBLY
23	1	8031240-23	3/8"-24 JAM NUT
24	1	8031240-24	SPRING CASE STUD
25	1	8031240-25	U-BOLT
26	4	8031240-26	1/4"-20 X 3/8" LOCKNUT
28	1	8031240-28	SWIVEL UNION

081010-E

VACASSY764

# Trailer Assy 512/599LEG

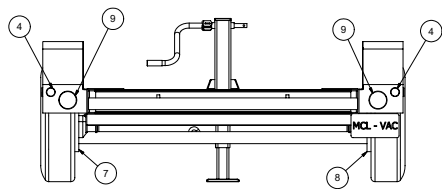
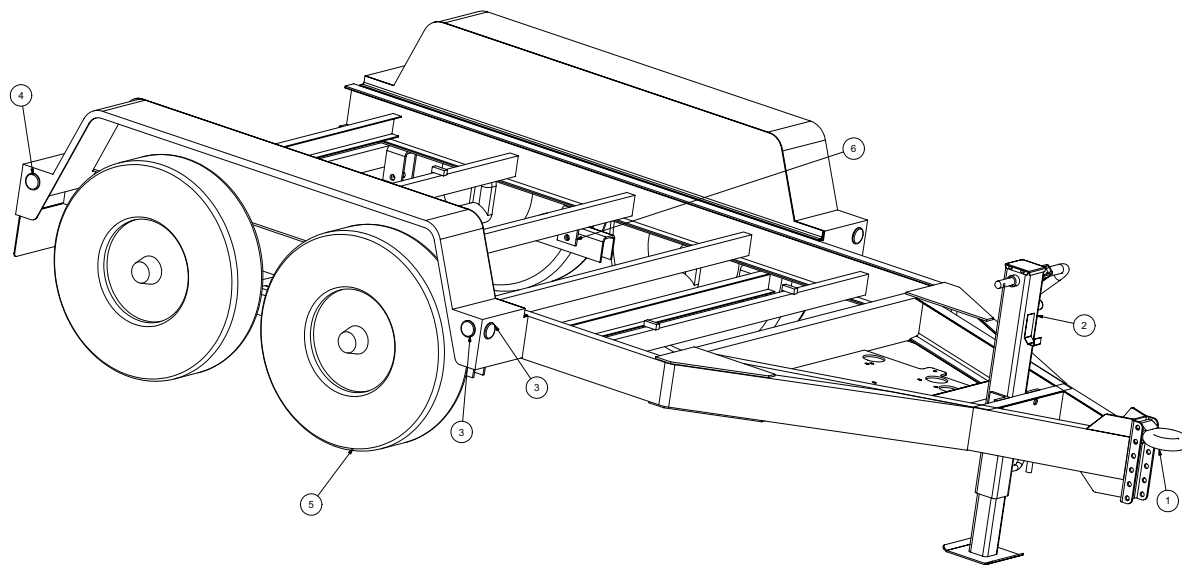

030314-E

VACASSY907

# Trailer Assy 512/599LEG

ITEM	QTY	PART #	DESCRIPTION
1	1	8043980	PINTLE EYE
2	1	8043548	JACK - MANUAL
	1	8043984	JACK HANDLE
3	4	8044000	2" YELLOW MARKER LIGHT
	4	8044002	2" RUBBER GROMMET
4	4	8043999	2" RED MARKER LIGHT
	4	8044002	2" RUBBER GROMMET
5	4	8045151	TIRE, ST235/80 R16
	4	8045152	WHEEL, R16 X 6
	2	8045153	DROP AXLE, LE/LEG
	4	8043986	HUB
	24	8043987	LUG NUT
	4	8047428	GREASE CAP
6	4	8043995	SPRING
	8	8043996	U-BOLT
	8	8043997	U-BOLT NUT
	4	8043998	TIE PLATE
7	1	8043990	LH BRAKE ASSEMBLY
	2	8043992	MAGNET KIT
	2	8043993	SHOE KIT
	1	8043994	ADJUSTER KIT
8	1	8043991	RH BRAKE ASSEMBLY
	2	8043992	MAGNET KIT
	2	8043993	SHOE KIT
	1	8043994	ADJUSTER KIT
9	2	8044001	4" STOP/TURN LIGHT
	2	8044003	4" GROMMET
*	1	8042381	FUEL TANK (14 GAL)
*	4	U000060	SCREW, HC 1/4-20 X 1"
*	4	U200020	WASHER, FLAT 1/4"

\* NOT SHOWN

# Trailer Assy

# 1200LEG

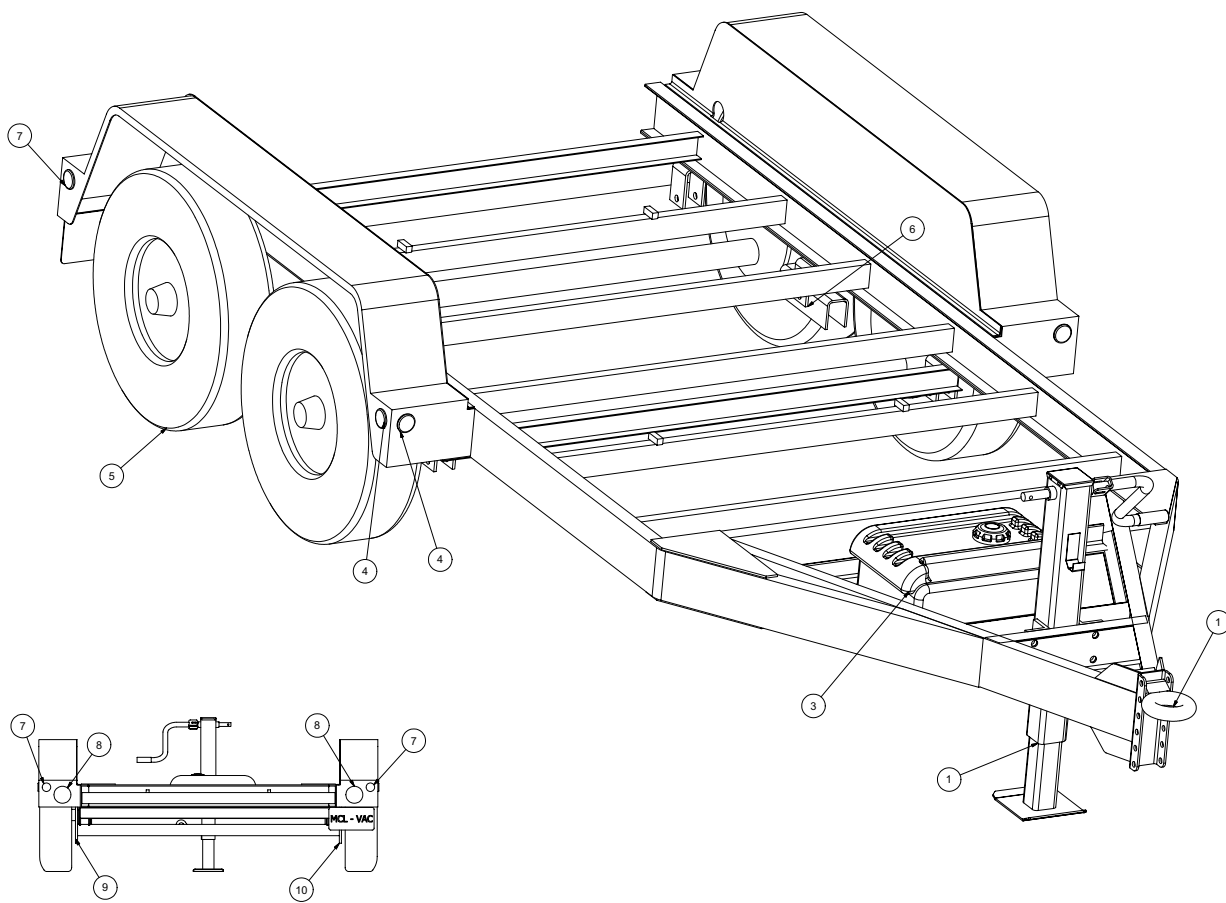

030314-E

VACASSY9300

# Trailer Assy

## 1200LEG

ITEM	QTY	PART #	DESCRIPTION
	1	8047881	TRAILER, 1200LEG
1	1	8043980	PINTLE EYE
2	1	8043548	JACK-MANUAL
	1	8043984	JACK HANDLE
3	1	8042381	TANK, FUEL PLASTIC 14GAL GAS
	1	8042381-1	TANK, FUEL CAP
	4	U000060	SCREW, HC 1/4-20 X 1.00"
	4	U200020	WASHER, FLAT 1/4"
4	4	8044000	2" YELLOW MARKER LIGHT
	4	8044002	2" RUBBER GROMMET
5	4	8046294	TIRE, ST 215 / 75 R 17.5
	4	8046295	WHEEL, R17.5 X 6.75
	2	8046296	DROP AXLE
	4	8046297	HUB
	24	8046298	LUG NUT
	4	8047429	GREASE CAP
6	4	8046299	SPRING
	8	8046301	U-BOLT
	8	8046302	U-BOLT NUT
	4	8046303	TIE PLATE
7	4	8043999	2" RED MARKER LIGHT
	4	8044002	2" RUBBER GROMMET
8	2	8044001	4" STOP/TURN LIGHT
	2	8044003	4" GROMMET
9	1	8046307	LH BRAKE ASSEMBLY
	2	8046304	MAGNET KIT
	2	8046305	SHOE KIT
	1	8046306	ADJUSTER KIT
10	1	8046308	RH BRAKE ASSEMBLY
	2	8046304	MAGNET KIT
	2	8046305	SHOE KIT
	1	8046306	ADJUSTER KIT
*	1	8046994	TIRE, SPARE

# Skid Assembly

# 500LEG 50GAL SADDLE

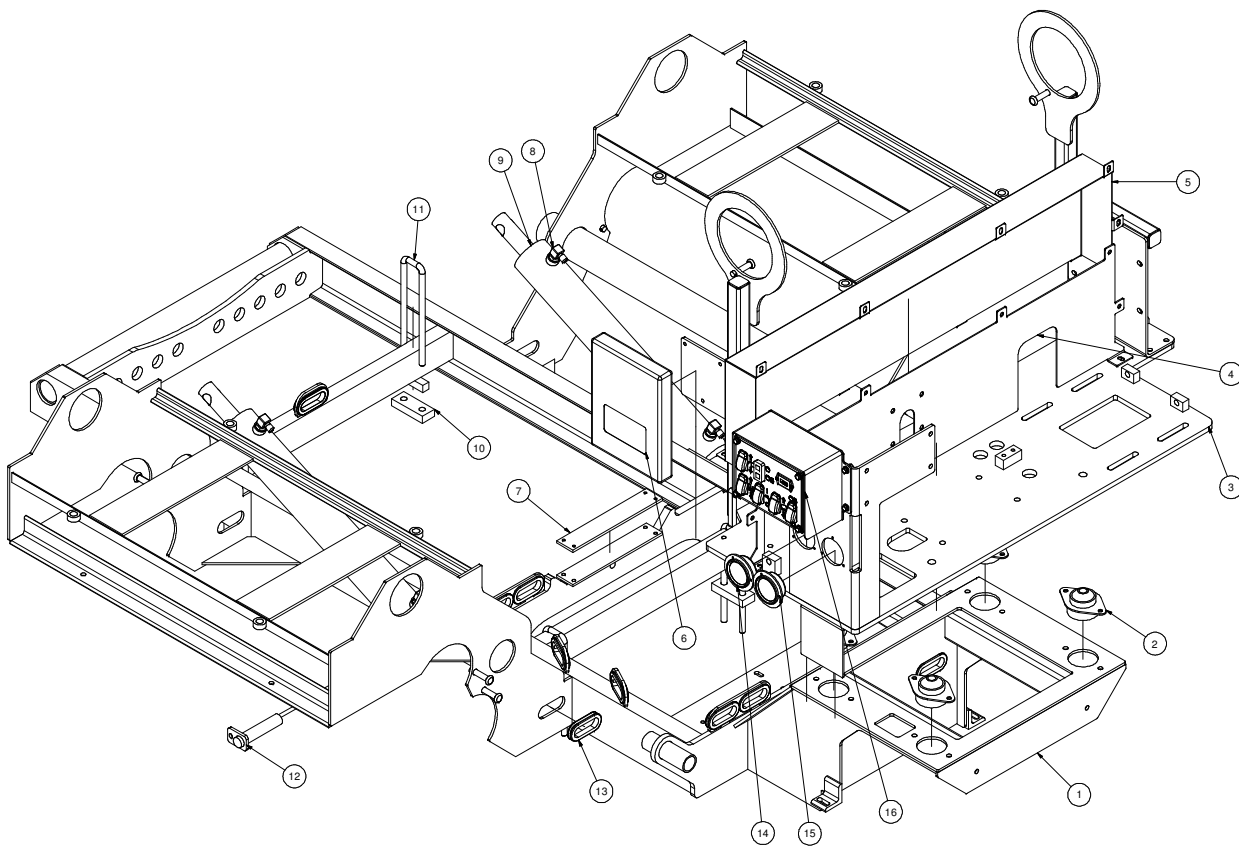

053013-E

VACASSY918



# Skid Assembly

# 500LEG 50GAL SADDLE

ITEM	QTY	PART #	DESCRIPTION
1	1	8044729	TANK SKID V500LEG
2	4	8030904	ISOLATOR 840LB
	4	U000560	SCREW, HC 3/8-16 X 3"
	4	8030851	WASHER, SNUBBLING
	4	U120110	NUT, LOCK 3/8"
	8	U000420	SCREW, HC 3/8-16 X 1"
	24	U200060	WASHER, FLAT 3/8"
	8	U210060	WASHER, LOCK 3/8"
	8	U100060	NUT, HEX 3/8-16
3	1	8045048	MAIN PLATE V750
4	1	8045303	GUARD BASE PANEL
5	1	8045304	GUARD ACCESS PANEL
6	1	E250210	BOX, PLASTIC FOR SAFETY MANUAL
7	1	8041376	PLASTIC STRIP, 1/4" X 2" X 11"
8	4	T401270	ELBOW, 90 1/2"MB - 3/8"MJ
9	2	8030359	CYLINDER, SPOIL TANK
10	4	8040240	U-BOLT MOUNTING BLOCK
11	4	8040038	U-BOLT, 1/2-13 X 10"LG - 1 5/8" GAP GR.8
	4	8040038-1	WASHER, 1/2"
	4	8040038-2	NUT, 1/2-20
12	2	8030128	CYLINDER PIN WELDMENT
	2	U000400	SCREW, HC 3/8"-16 X .750
13	14	8042812	GROMMET 2"ID 3"OD 1/4"WOG TRAILER SLOT MODEL
14	1	8030372	GAUGE, 5000PSI 2.5"LF CBM
15	1	8041074	GAUGE, PRESSURE/VACUUM
16	1	8048625	LEG CONTROL BOX LG COMPLETE
*	1	X300297	CABLE BATTERY KIT 31HP

\* NOT SHOWN

# Skid Assembly

# 500LEG 125GAL SADDLE

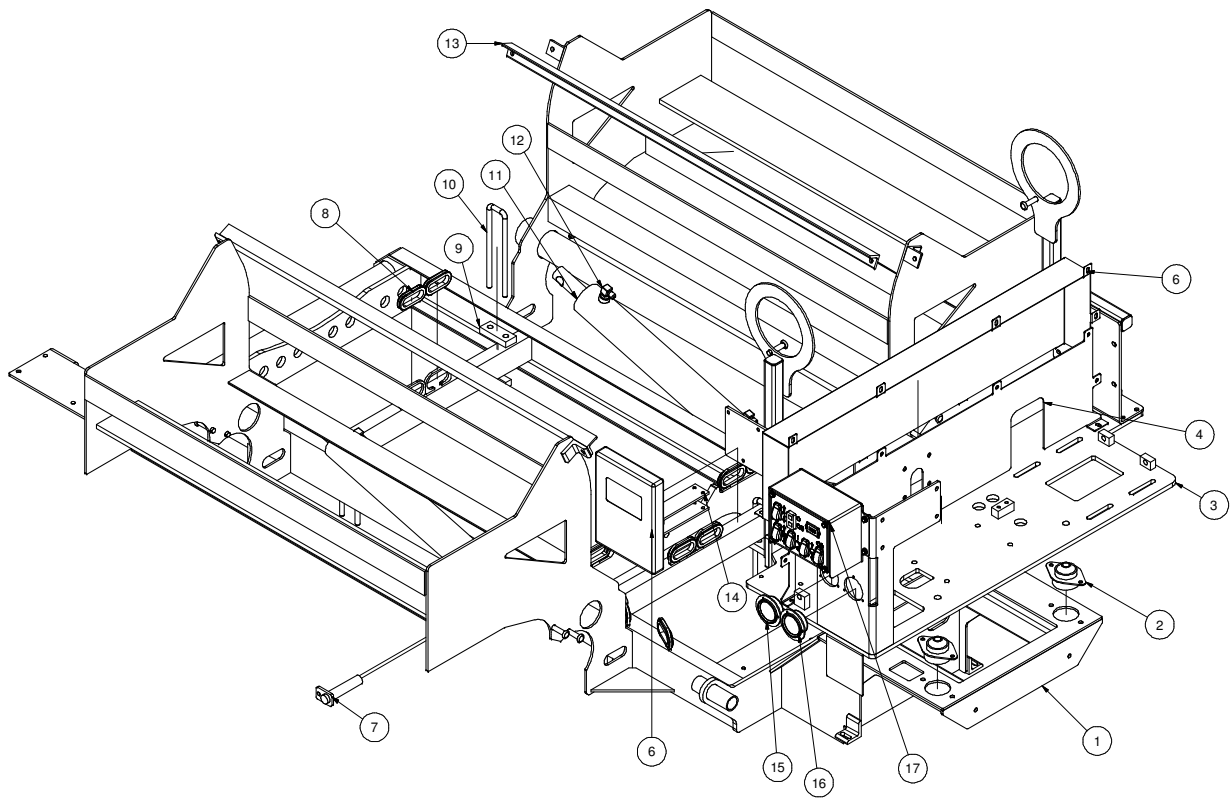

052913-E

VACASSY919

# Skid Assembly

# 500LEG 125GAL SADDLE

ITEM	QTY	PART #	DESCRIPTION
1	1	8045136	TANK SKID V500LEG
2	4	8030904	ISOLATOR 840LB
	4	U000560	SCREW, HC 3/8-16 X 3"
	4	8030851	WASHER, SNUBBLING
	4	U120110	NUT, LOCK 3/8"
	8	U000420	SCREW, HC 3/8-16 X 1"
	24	U200060	WASHER, FLAT 3/8"
	8	U210060	WASHER, LOCK 3/8"
	8	U100060	NUT, HEX 3/8-16
3	1	8045048	MAIN PLATE 750MS
4	1	8045303	GUARD BASE PANEL
5	1	8045304	GUARD ACCESS PANEL
6	1	E250210	BOX, PLASTIC FOR SAFETY MANUAL
7	2	8030128	CYLINDER PIN WELDMENT
	2	U000400	SCREW, HC 3/8"-16 X .750
8	12	8042812	GROMMET 2"ID 3"OD 1/4"WOG TRAILER SLOT MODEL
9	4	8040240	U-BOLT MOUNTING BLOCK
10	4	8040038	U-BOLT, 1/2-13 X 10"LG - 1 5/8" GAP GR.8
	4	8040038-1	WASHER, 1/2"
	4	8040038-2	NUT, 1/2-20
11	2	8030359	CYLINDER, SPOIL TANK
12	4	T401270	ELBOW, 90 1/2"MB - 3/8"MJ
13	2	8044456	WATER TANK ANGLE 125 GAL
14	2	8041376	PLASTIC STRIP, 1/4" X 1 1/2" X 30"
	6	U030015	SCREW SOCKET FLAT HEAD 1/4-20 X 3/4"
15	1	8030372	GAUGE, 5000PSI 2.5"LF CBM
16	1	8041074	GAUGE, PRESSURE/VACUUM
17	1	8048625	LEG CONTROL BOX LG COMPLETE

\* 1 X300297 CABLE BATTERY KIT 31HP

\* NOT SHOWN

# Skid Assembly

# 500LEG 125GAL SADDLE (HYD DOOR)

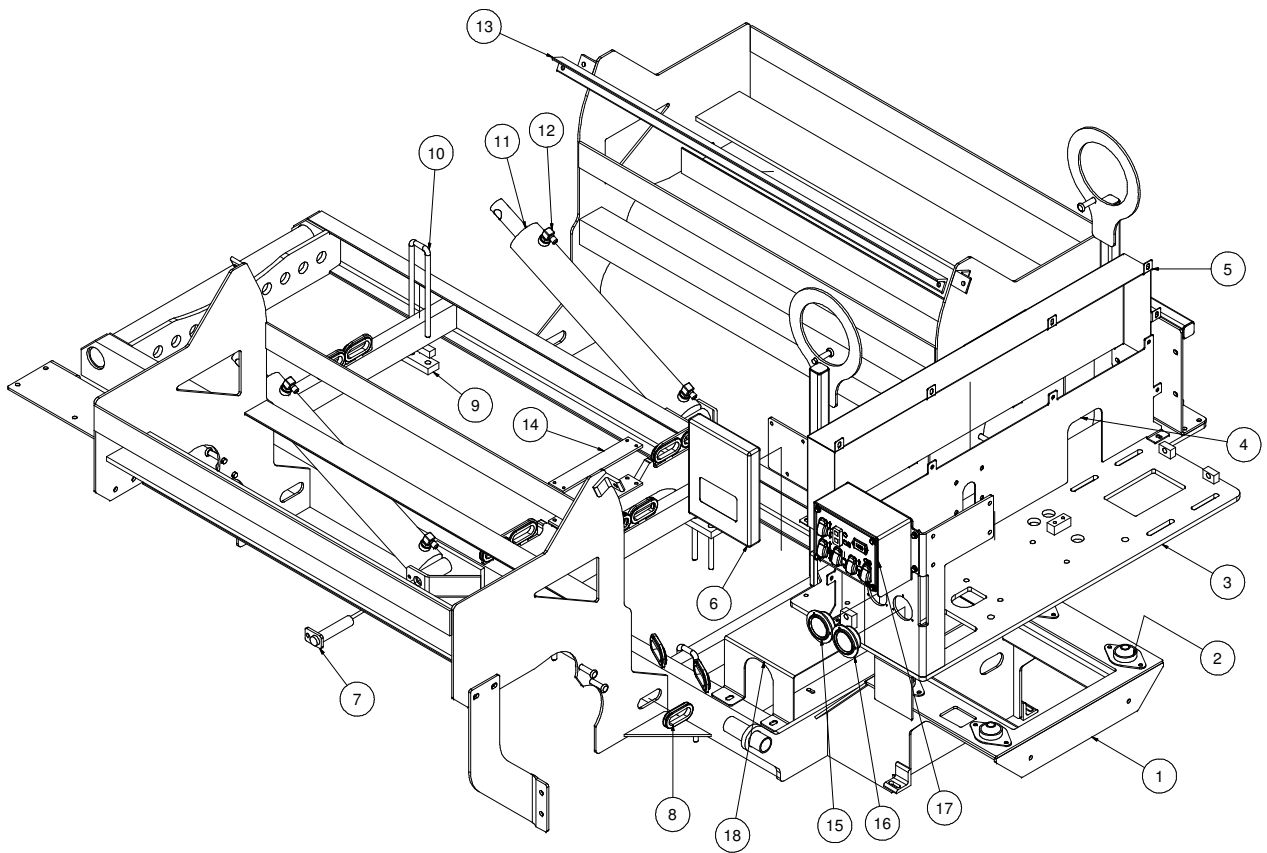

053013-E

VACASSY01105

# Skid Assembly

# 500LEG 125GAL SADDLE (HYD DOOR)

ITEM	QTY	PART #	DESCRIPTION
1	1	8048392	TANK SKID V500LEG
2	4	8030904	ISOLATOR 840LB
	4	U000560	SCREW, HC 3/8-16 X 3"
	4	8030851	WASHER, SNUBBLING
	4	U120110	NUT, LOCK 3/8"
	8	U000420	SCREW, HC 3/8-16 X 1"
	24	U200060	WASHER, FLAT 3/8"
	8	U210060	WASHER, LOCK 3/8"
	8	U100060	NUT, HEX 3/8-16
3	1	8045048	MAIN PLATE 750MS
4	1	8045303	GUARD BASE PANEL
5	1	8045304	GUARD ACCESS PANEL
6	1	E250210	BOX, PLASTIC FOR SAFETY MANUAL
7	2	8030128	CYLINDER PIN WELDMENT
	2	U000400	SCREW, HC 3/8"-16 X .750
8	12	8042812	GROMMET 2"ID 3"OD 1/4"WOG TRAILER SLOT MODEL
9	4	8040240	U-BOLT MOUNTING BLOCK
10	4	8040038	U-BOLT, 1/2-13 X 10"LG - 1 5/8" GAP GR.8
	4	8040038-1	WASHER, 1/2"
	4	8040038-2	NUT, 1/2-20
11	2	8030359	CYLINDER, SPOIL TANK
12	4	T401270	ELBOW, 90 1/2"MB - 3/8"MJ
13	2	8044456	WATER TANK ANGLE 125 GAL
14	2	8041376	PLASTIC STRIP, 1/4" X 1 1/2" X 30"
	6	U030015	SCREW SOCKET FLAT HEAD 1/4-20 X 3/4"
15	1	8030372	GAUGE, 5000PSI 2.5"LF CBM
16	1	8041074	GAUGE, PRESSURE/VACUUM
17	1	8048625	LEG CONTROL BOX LG COMPLETE
18	1	8048447	HYD. PUMP COVER LEG 125 HYD.
*	1	X300297	CABLE BATTERY KIT 31HP

\* NOT SHOWN

053013-E

VACASSY01105

# Skid Assembly

# 800LEG 50GAL SADDLE

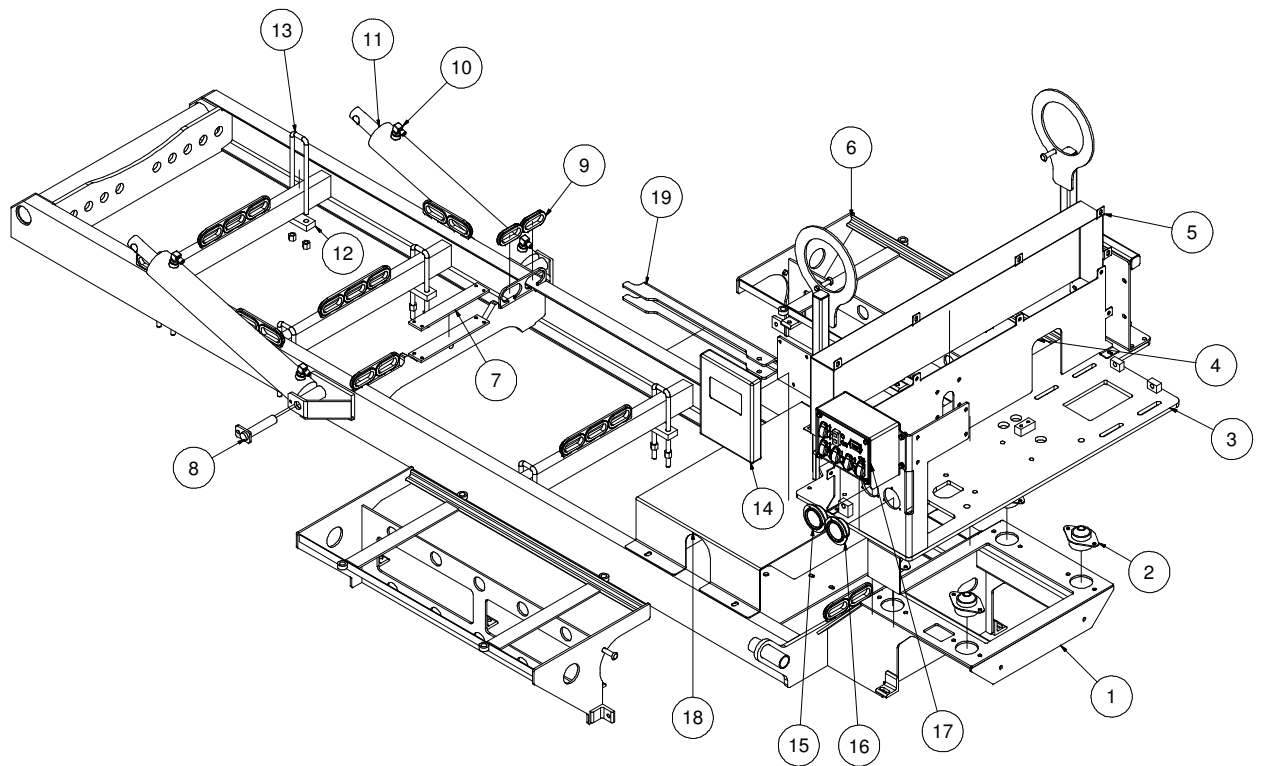

053013-E

VACASSY01100

# Skid Assembly

# 800LEG 50GAL SADDLE

ITEM	QTY	PART #	DESCRIPTION
1	1	8048723	TANK SKID V800LEG
2	4	8030904	ISOLATOR 840LB
	4	U000560	SCREW, HC 3/8-16 X 3"
	4	8030851	WASHER, SNUBBLING
	4	U120110	NUT, LOCK 3/8"
	8	U000420	SCREW, HC 3/8-16 X 1"
	24	U200060	WASHER, FLAT 3/8"
	8	U210060	WASHER, LOCK 3/8"
	8	U100060	NUT, HEX 3/8-16
3	1	8045048	MAIN PLATE V750
4	1	8045303	GUARD BASE PANEL
5	1	8045304	GUARD ACCESS PANEL
6	2	8047933	WATER TANK BRACKET 50 GAL
7	1	8041376	PLASTIC STRIP, 1/4" X 2" X 11"
8	2	8030128	CYLINDER PIN WELDMENT
	2	U000400	SCREW, HC 3/8"-16 X .750
9	18	8042812	GROMMET 2"ID 3"OD 1/4"WOG TRAILER SLOT MODEL
10	4	T401270	ELBOW, 90 1/2"MB - 3/8"MJ
11	2	8030359	CYLINDER, SPOIL TANK
12	4	8040240	U-BOLT MOUNTING BLOCK
13	4	8040038	U-BOLT, 1/2-13 X 10"LG - 1 5/8" GAP GR.8
	4	8040038-1	WASHER, 1/2"
	4	8040038-2	NUT, 1/2-20
14	1	E250210	BOX, PLASTIC FOR SAFETY MANUAL
15	1	8030372	GAUGE, 5000PSI 2.5"LF CBM
16	1	8041074	GAUGE, PRESSURE/VACUUM
17	1	8048625	LEG CONTROL BOX LG COMPLETE
18	1	8048726	HYD. PUMP COVER V800LEG
19	1	8041212	TANK SAFETY BRACE
*	1	X300297	CABLE BATTERY KIT 31HP

\* NOT SHOWN

053013-E

VACASSY01100

# Skid Assembly

# 1200LEG 50GAL SADDLE

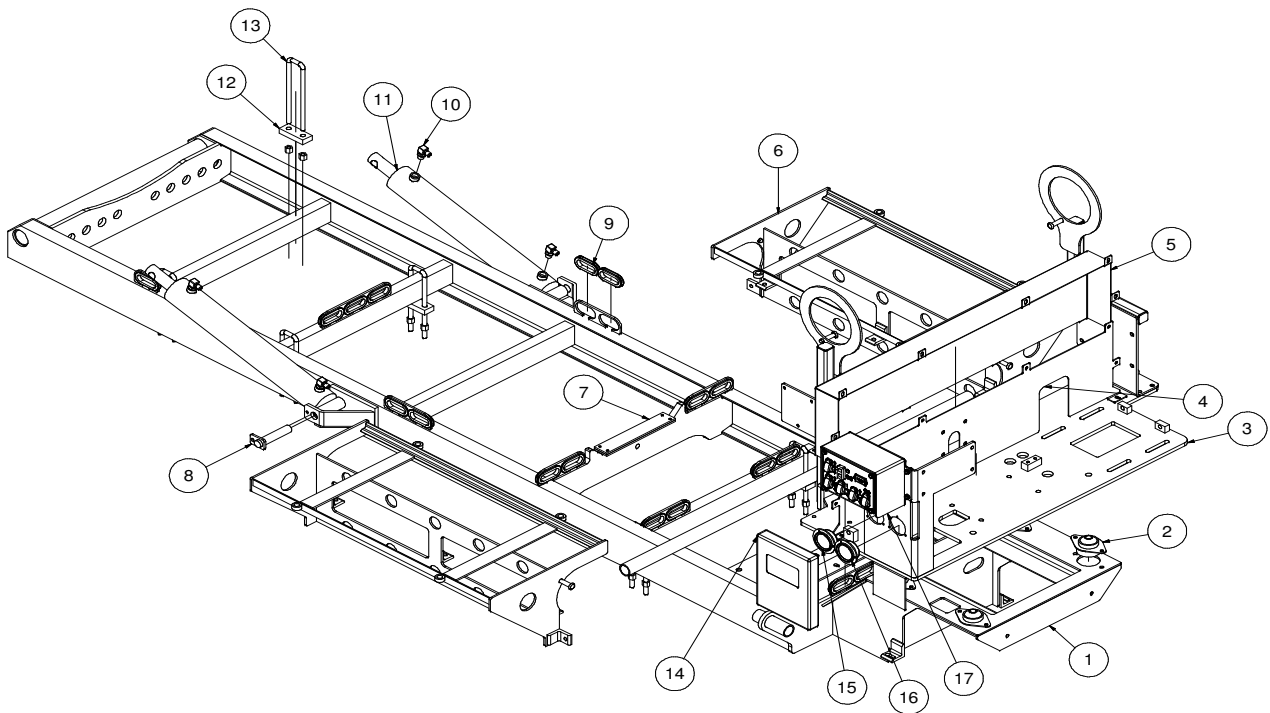

052913-E

VACASSY885



# Skid Assembly

# 1200LEG 50GAL SADDLE

ITEM	QTY	PART #	DESCRIPTION
1	1	8047880	TANK SKID V1200LEG
2	4	8030904	ISOLATOR 840LB
	4	U000560	SCREW, HC 3/8-16 X 3"
	4	8030851	WASHER, SNUBBLING
	4	U120110	NUT, LOCK 3/8"
	8	U000420	SCREW, HC 3/8-16 X 1"
	24	U200060	WASHER, FLAT 3/8"
	8	U210060	WASHER, LOCK 3/8"
	8	U100060	NUT, HEX 3/8-16
3	1	8045048	MAIN PLATE V750
4	1	8045303	GUARD BASE PANEL
5	1	8045304	GUARD ACCESS PANEL
6	2	8047933	WATER TANK BRACKET 50 GAL
7	1	8041376	PLASTIC STRIP, 1/4" X 2" X 11"
8	2	8030128	CYLINDER PIN WELDMENT
	2	U000400	SCREW, HC 3/8"-16 X .750
9	18	8042812	GROMMET 2"ID 3"OD 1/4"WOG TRAILER SLOT MODEL
10	4	T401270	ELBOW, 90 1/2"MB - 3/8"MJ
11	2	8030359	CYLINDER, SPOIL TANK
12	4	8040240	U-BOLT MOUNTING BLOCK
13	4	8040038	U-BOLT, 1/2-13 X 10"LG - 1 5/8" GAP GR.8
	4	8040038-1	WASHER, 1/2"
	4	8040038-2	NUT, 1/2-20
14	1	E250210	BOX, PLASTIC FOR SAFETY MANUAL
15	1	8030372	GAUGE, 5000PSI 2.5"LF CBM
16	1	8041074	GAUGE, PRESSURE/VACUUM
17	1	8048625	LEG CONTROL BOX LG COMPLETE
*	1	X300297	CABLE BATTERY KIT 31HP

\* NOT SHOWN

# Hydraulic Jack Option

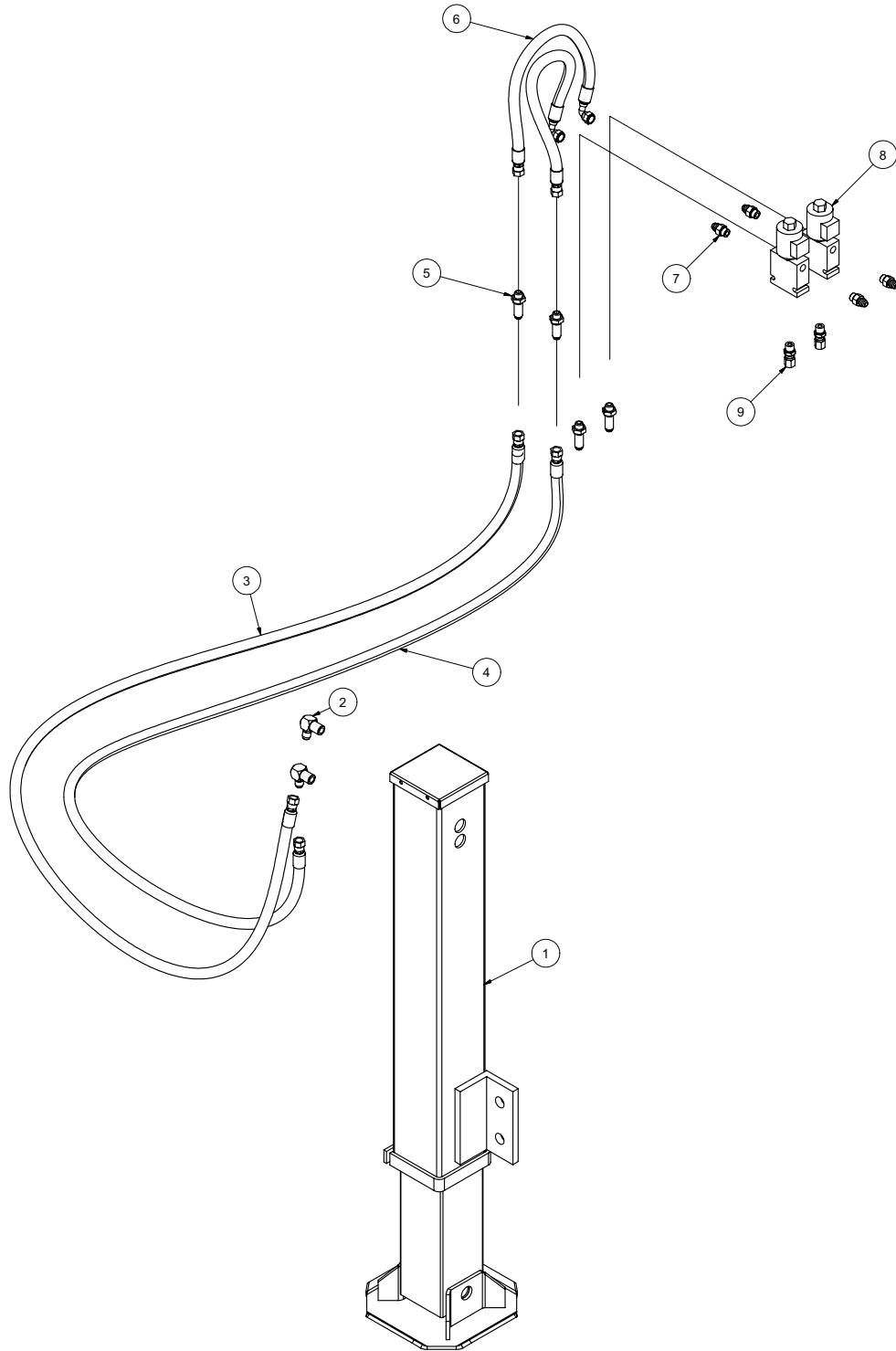

072808

VACASSY956

# Hydraulic Jack Option

ITEM	QTY	PART #	DESCRIPTION
1	1	8043653	HYDRAULIC JACK CYLINDER
2	2	T401103	ELBOW 90 DEG 3/8"MJ - 1/4"FJ
3	1	8042661	HOSE ASSY VAC 6-66 ST-90
4	1	8041442	HOSE ASSY VAC 6-60 ST-90
5	2	T400391	BULKHEAD, 3/8"MJ - 3/8"MJ
6	2	8040973	HOSE ASSY VAC 6-20 ST-90
7	4	T400037	UNION, 3/8"MB - 3/8"MJ
8	2	8041788	SOLENOID VALVE
9	2	8030512	UNION, 3/8"MB - 3/8"FJ
*	1	X000274	SWITCH ROCKER DPDT

\* NOT SHOWN

072808

VACASSY956

# Surge Brake Option

# V500

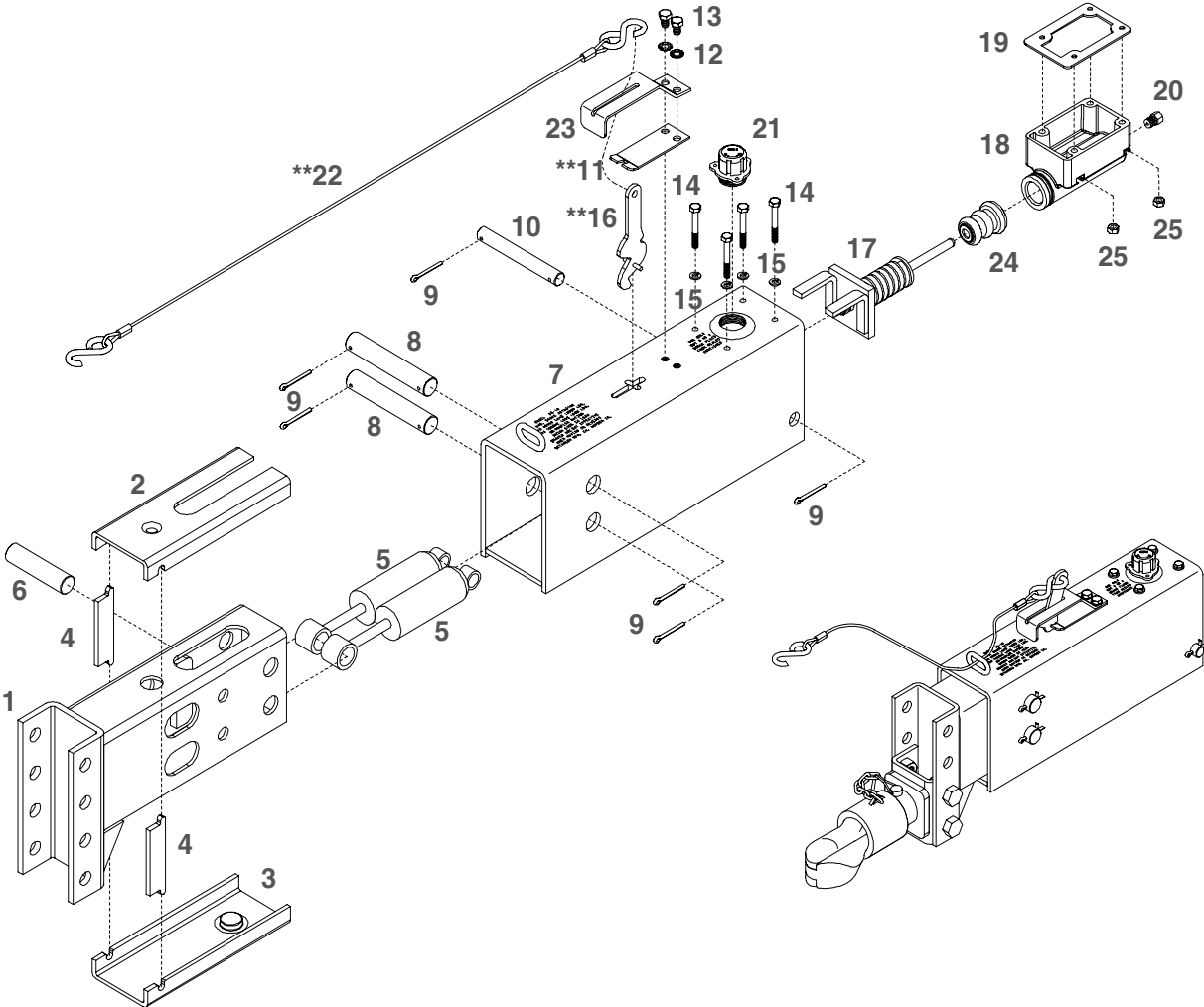

051408

VACASSY948

# Surge Brake Option

# V500

ITEM	QTY	NUMBER	DESCRIPTION
1	1	8040790-1	INNER SLIDER TUBE CHAN. DOWN
2	1	8040790-2	TOP WEAR PAD
3	1	8040790-3	BOTTOM WEAR PAD
4	2	8040790-4	SPACER BLOCK
5	2	8040790-5	DAMPER SHOCK
6	1	8040790-6	FRONT SHOCK PIN (ZINC PLATED)
7	1	8040790-7	OUTER CASE
8	2	8040790-8	CONNECTING PIN (ZINC PLATED)
9	6	8040790-9	5/32" X 1-1/4" COTTER PIN
10	1	8040790-10	REAR SHOCK PIN (ZINC PLATED)
11	1	8040790-11	EMERGENCY LEVER SPRING (ZINC PLATED)
12	2	8040790-12	5/16" EXTERNAL TOOTH LOCK WASHER
13	2	8040790-13	5/16"-18 UNC X 5/8" HEX HEAD BOLT GR.5
14	4	8040790-14	1/4"-20 UNC X 2" HEX HEAD BOLT GR.5
15	4	8040790-15	1/4" LOCK WASHER
16	1	8040790-16	EMERGENCY LEVER (ZINC PLATED)
17	1	8040790-17	PUSH ROD ASSEMBLY
18	1	8040790-18	COMPOSITE MASTER CYLINDER (DRUM BRAKES)
19	1	8040790-19	REPLACEMENT MASTER CYL. GASKET ONLY
20	1	8040790-20	1/8" PIPE-3/16" FITTING W/ORIFICE (DRUM)
21	1	8040790-21	MASTER CYLINDER CAP W/DIAPHRAGM AND O-RING
22	1	8040790-22	3/32" CABLE WITH HOOKS (BOTH ENDS)
23	1	8040790-23	LEVER GUIDE (ZINC PLATED)
24	1	8040790-24	MASTER CYL. PROTECTIVE BOOT
25	4	8040790-25	1/4"-20 UNC HEX NUTS

051408

VACASSY948

# HOSES

3"

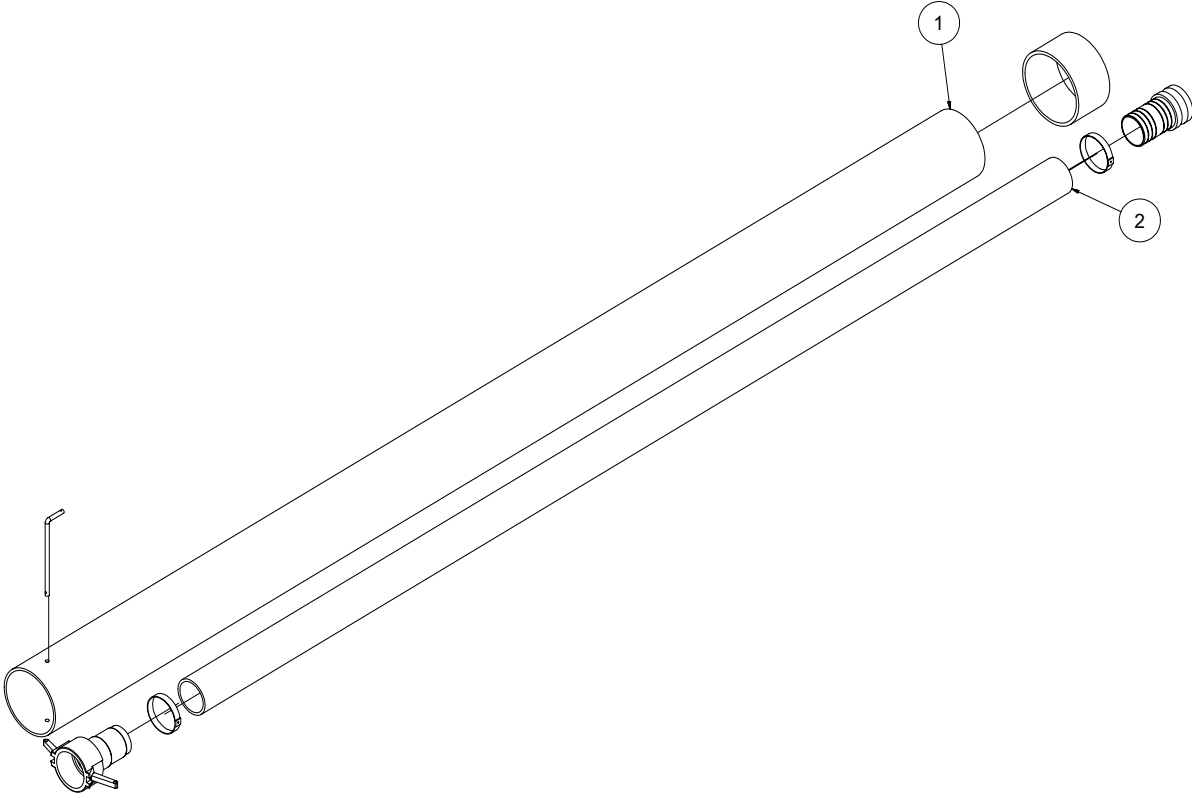

# HOSES

# 3''

ITEM	QTY	PART NO.	DESCRIPTION	
1	1	8041102	6" PVC STORAGE TUBE 10' LG	
	1	8030925	END CAP 6"	
	1	8041485	LANYARD CABLE	
	1	8043198	HOSE STORAGE CLAMP	
	2	U200060	WASHER. FLAT 3/8"	
	2	U100060	NUT, HEX 3/8"	
	1	8041101	HOSE STORAGE RETAINING ROD	
	1	R700170	R-CLIP, 1/2 - 5/8 SHANK	
	2	1	8040338	HOSE VAC KANAFLEX 3-110"
		1	8046441	CAMLOCK, 3" AL FCAM X M BARB
1		8046440	CAMCOCK, 3" AL MCAM X M BARB	
2		8030356	CLAMP, 4.5" PUNCHLOCK P18-S	

# Tools (Option)

# Reduction Tool 100G/LEG

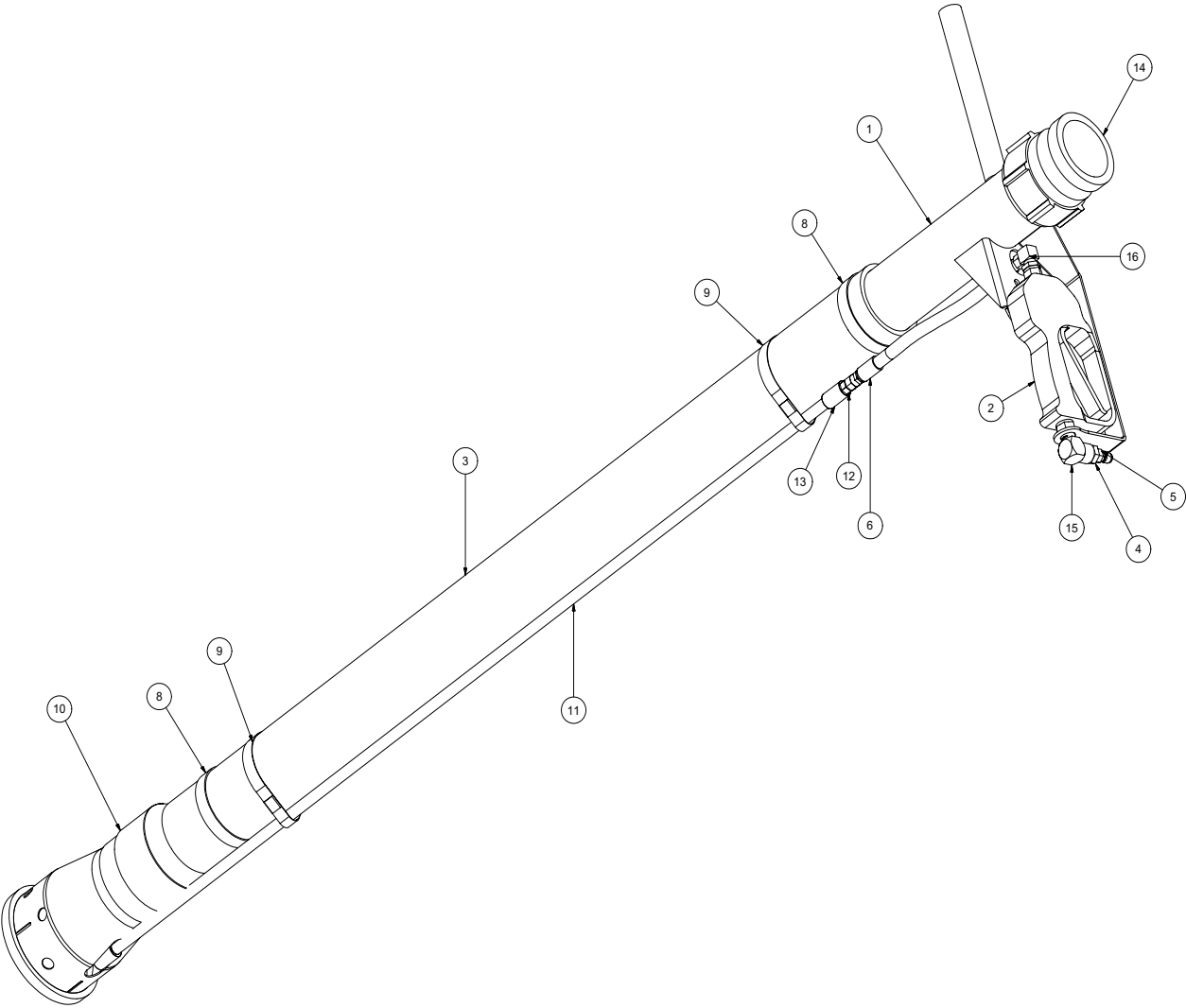

012213-E

VACASSY01700



# Tools(Optional)

# Reduction Tool 100G/LEG

ITEM	QTY	PART NO.	DESCRIPTION
-	-	8043113	TOOL VAC REDUCTION 100G/LEG COMPLETE
1	1	8042862	TOOL VAC HEAD ASSY 3"
2	1	8048567	STRAIGHT SPRAY GUN
3	1	8042811	TOOL VAC REDUCTION PVC 3" X 48"
4	1	T400023	UNION 6MP 4FP
5	1	8030486	WATER QD 1/4 MNPT SS
6	2	T320030	FITTING, HOSE 4HO 4FJ
7	1	8031278	HOSE ASSEMBLY REDUCTION TOOL
8	2	8042605	CLAMP HOSE T BOLT 350
9	2	8042855	CLAMP HOSE T BOLT 375
10	1	8030627	TOOL VAC REDUCTION LOWER ASSY
11	1	8043764	VAC WATER SUPPLY TUBE CHROME 1/4NPT
12	1	T400020	UNION 1/4" MP-1/4" MJ STRAIGHT
13	2	T422010	COUPLING PIPE 1/4"FP
14	1	8030391	BANJO 3" MALE 3" FNPT
15	1	T401065	ELBOW, 3/8 MP - 3/8 FP
16	1	T401100	ELBOW 4MP 4MJ 90
*	2	8030370	REDUCTION TOOL NOZZLE #2 0DEG

\* NOT SHOWN

**Tools**

**3" Suction Tool**

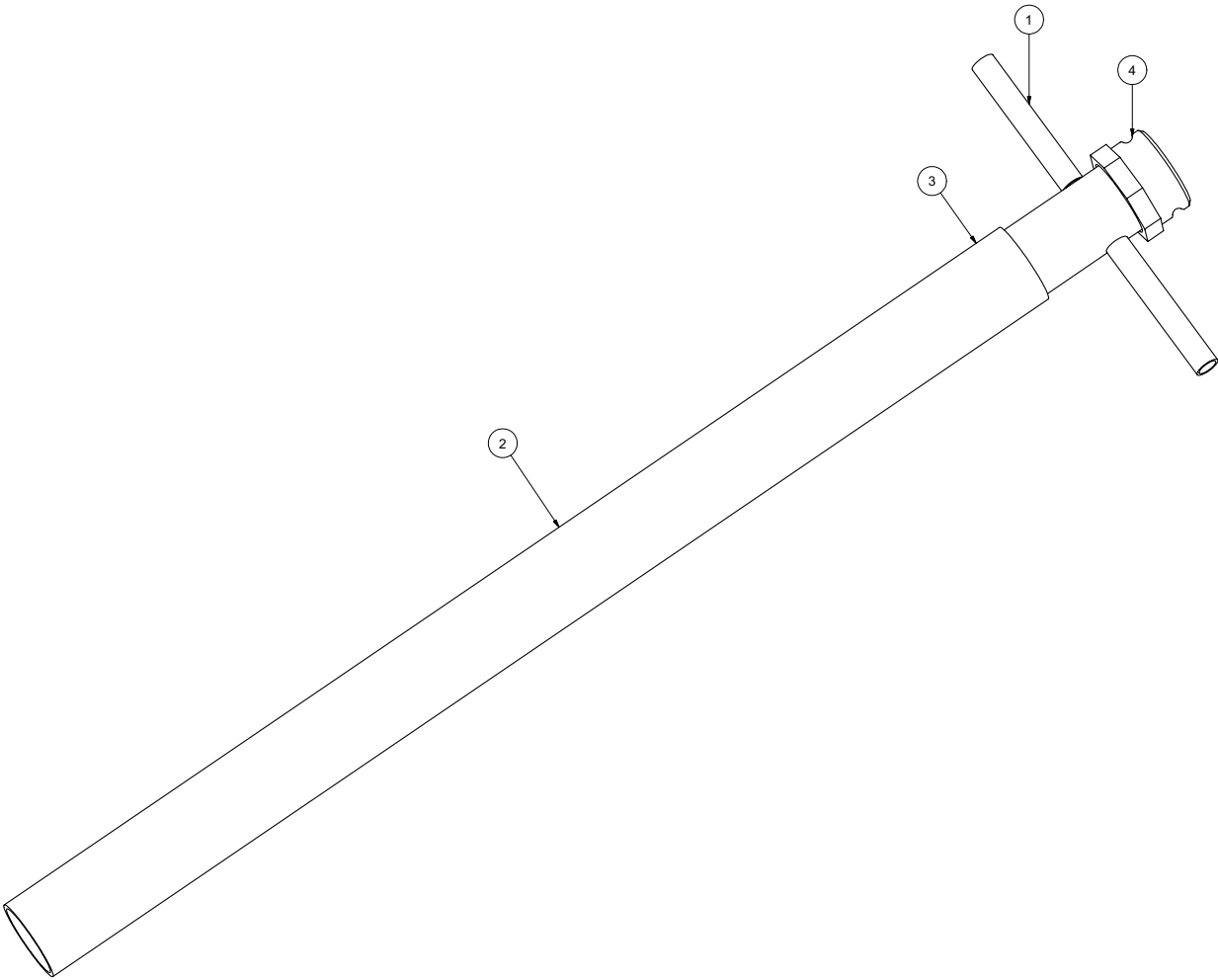

111210-E

VACASSY712

# Tools

# 3" Suction Tool

ITEM	QTY	NUMBER	DESCRIPTION
	1	8030215	TOOL VAC SUCTION 3" COMPLETE
1	1	8030317	TOOL VAC HANDLE ASSEMBLY 3"
2	1	8030313	PVC VACUUM TUBE 3"
3	1	8030356	CLAMP,4"PUNCHLOCK P16-S
4	1	8030391	COUPLING, 3" BANJO

111210-E

VACASSY712

# Tools

# Wash Wand

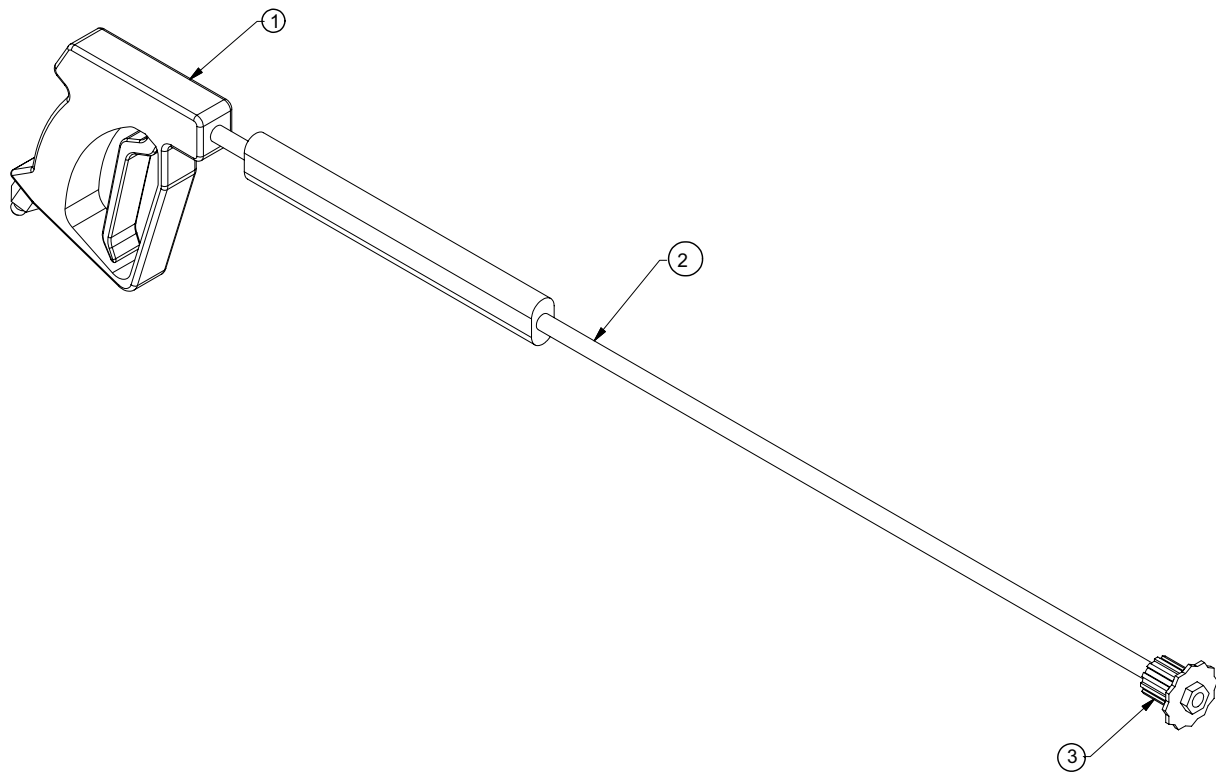

042610-E

VACASSY711

# Tools

# Wash Wand

<b>Item</b>	<b>Qty</b>	<b>Number</b>	<b>Description</b>
1	1	8030348	TOOL VAC SPRAY WAND COMPLETE
2	1	8030928	TRIGGERASSEMBLY
3	1	8030847	WAND
		8031308	NOZZLE,#6 40 DEGREE FOR WAND

042610-E

VACASSY711

# Valve Box Cleanout Tool

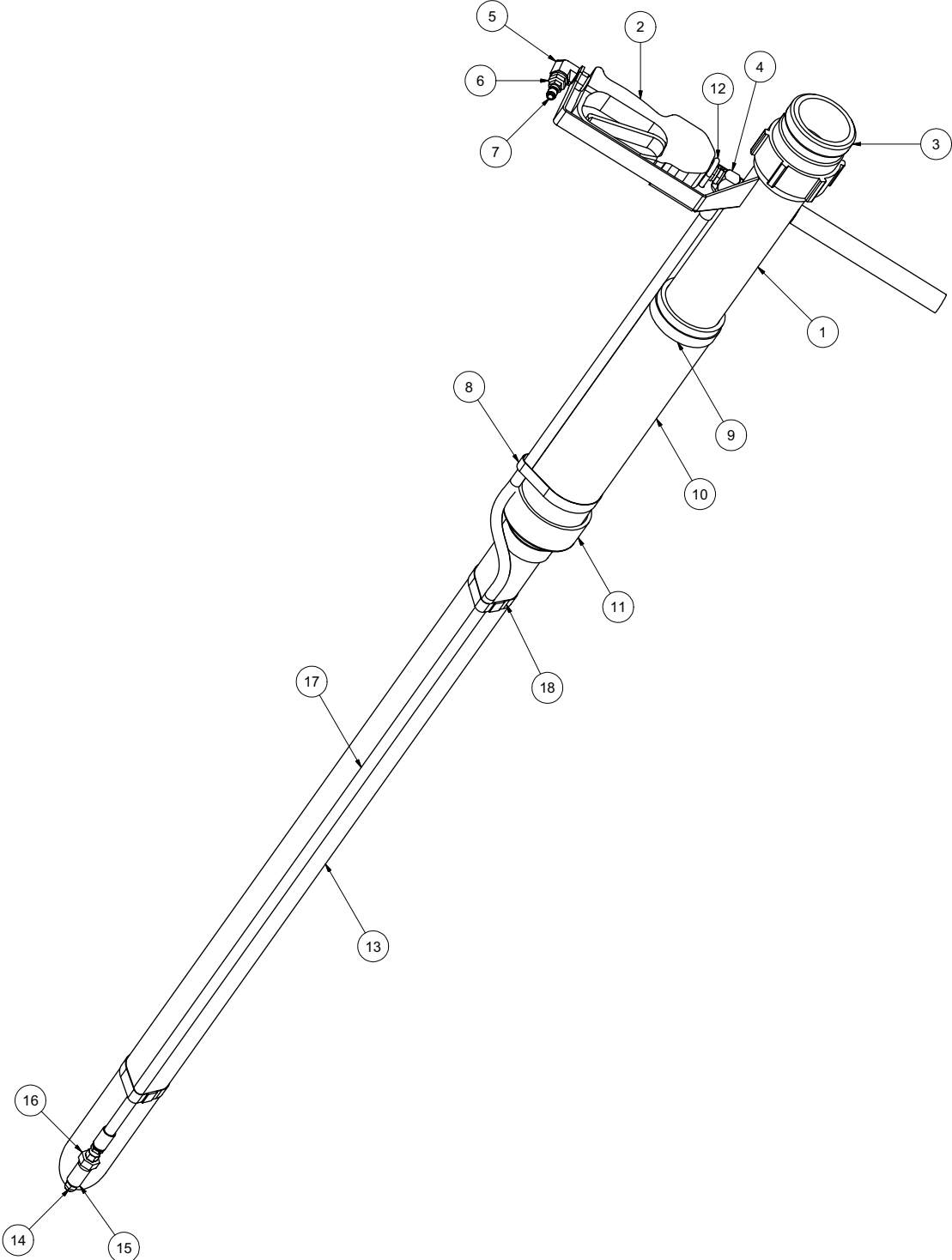

101812-E

VACASSY714

# Valve Box Cleanout Tool

ITEM	QTY	PART NO.	DESCRIPTION
	1	8043384	VAC TOOL VALVEBOX CLEANOUT COMPLETE
1	1	8042862	REDUCTION TOOL HEAD WELD'T
2	1	8048567	STRAIGHT SPRAY GUN
3	1	8030391	BANJO 3" MALE FNPT
4	1	T401100	ELBOW 4MP 4MJ 90
5	1	T401065	ELBOW, 3/8 MP - 3/8 FP
6	1	T400023	REDUCER 6MP 4FP
7	1	8030486	WATER QD 1/4 MNPT SS
8	1	8042855	CLAMP HOSE T-BOLT 375
9	1	8042605	CLAMP HOSE T-BOLT 350
10	1	8044096	PVC 3" DIA X 9" LONG
11	1	8030669	REDUCER PVC 3" TO 2" SLIP ON
12	1	U010019	U-BOLT 1_4-20 X 3_4 WIDE X 2 1_4 LONG
13	1	8044097	PVC 2" DIA X 42.5" LG
14	1	8031246	NOZZLE, .100 X 0 DEG
15	1	T422010	COUPLING 1/4"FP
16	1	U400020	UNION, 1/4" MP - 1/4" MJ
17	1	8044098	HOSE ASSY VALVE BOX CLEANOUT TOOL
18	2	8045316	CLAMP, HOSE T-BOLT 275

# Tools

# Rotary Lance 100G & LEG

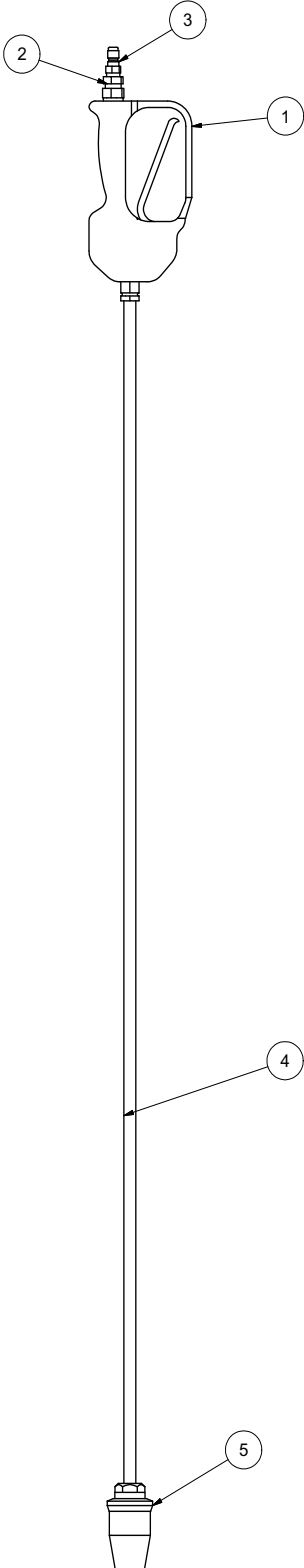



# Tools

# Rotary Lance 100G & LEG

ITEM	QTY	PART NO.	DESCRIPTION
*		8042082	TOOL VAC ROTARY LANCE COMPLETE
1	1	8048567	STRAIGHT SPRAY GUN
2	1	T400023	UNION 6MP-4FP
3	1	8030486	WATER QD 1/4MNPT SS
4	1	8043765	TUBE,CHROME 1/4NPT ENDS 60"
5	1	8048739	NOZZLE ROTATING 055

# Tools

# Lawn Sweeper 3''

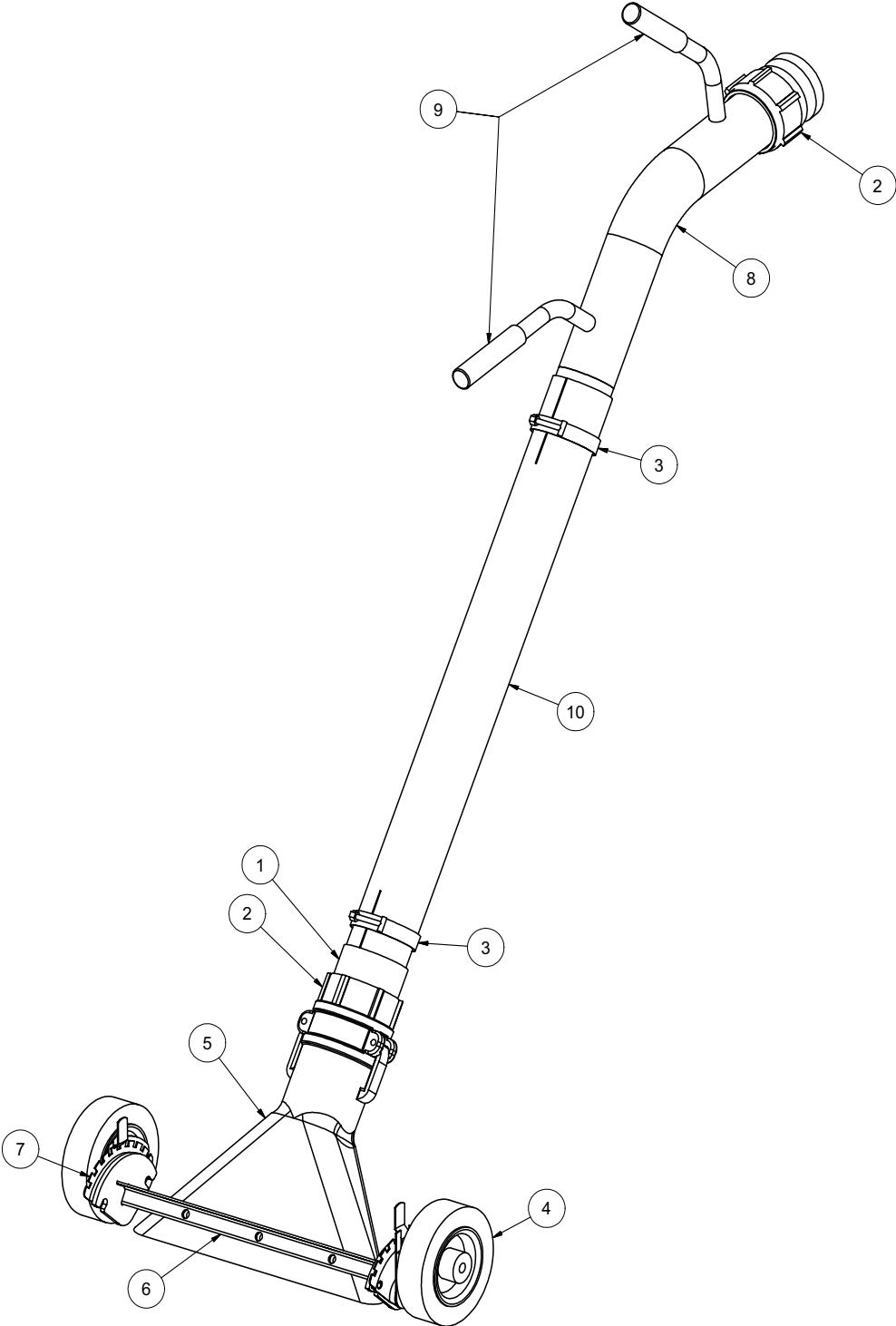

101512-E

VACASSY713

# Tools

# Lawn Sweeper 3''

ITEM	QTY	PART #	DESCRIPTION
	1	8043935	VAC TOOL LAWN SWEEPER COMPLETE
1	1	8030287	3" HOSE X 3" MNPT ADAPTER
2	2	8030391	BANJO 3" MALE 3" FNPT
3	2	8042605	CLAMP T-BOLT 3" (350)
4	2	8043887	WHEEL 6" PNEUMATIC
5	1	8043925	DUCKBILL 3" ALUMINUM
6	1	8043928	LS WHEEL WELDMENT
7	1	8043931	WHEELADJUSTERS (1 LEFT/1 RIGHT)
8	1	8043933	LS HANDLE WELDMENT
9	2	J300080	HANDLE GRIP
10	1	8043932	PVC 3" X 30"

101512-E

VACASSY713

# Surface Cleaner

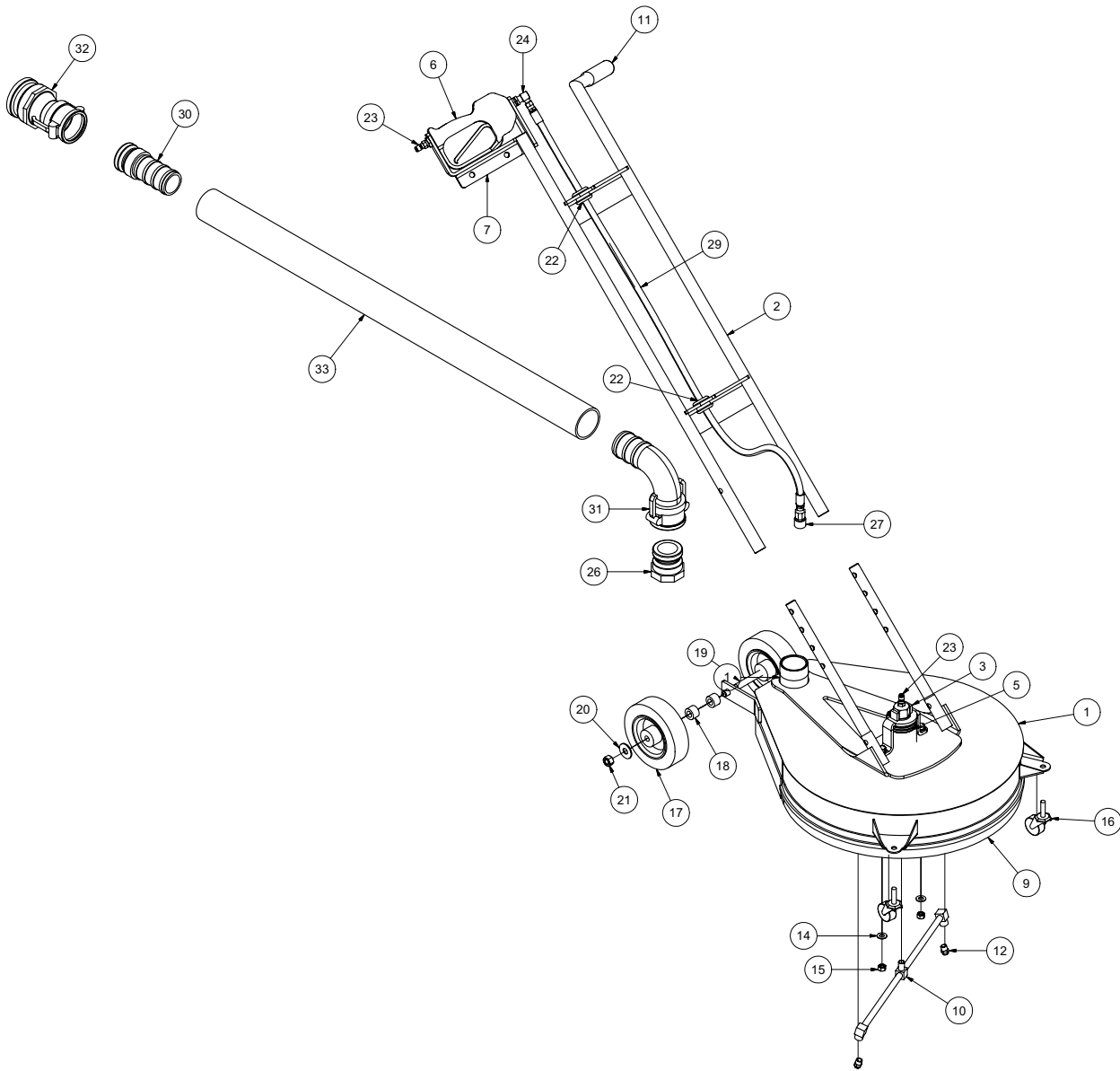

101812-E

VACASSY715

# Surface Cleaner

ITEM	QTY	PART NO.	DESCRIPTION
	1	8043480	VAC TOOL SURFACE CLEANER COMPLETE
1	1	8041887	SURFACE CLEANER - HEAD ASSY
2	1	8042019	HANDLE ASSY
3	1	8041890	ROTARY RETAINER
4	2	8042022	HANDLE ADJ. TUBE
5	1	8042027	ROTARY HEAD
6	1	8048567	STRAIGHT SPRAY GUN
7	1	8042020	GUN CAPTURE BRACKET
8	1	8043467	SQUEEGEE
9	1	8042030	FLEXIBLE BRUSH
10	1	8042028	ROTARY ARM
11	1	J300080	GRIPHANDLE
12	2	8031419	NOZZLE, #4.0 25 DEG
13	2	U000420	SCREW, HC 3/8-16 X 1.00
14	4	U200600	WASHER, FLAT 3/8"
15	2	U100060	NUT, HEX 3/8-16
16	2	8043387	SWIVEL CASTER 1 5/8"
17	2	8043887	WHEEL 6" PNEUMATIC
18	2	8043591	SURFACE CLEANER REAR WHEEL SPACER
19	1	U001060	SCREW, HC 1/2-13 X 6.0
20	2	U200100	WASHER, FLAT 1/2"
21	1	U120120	NUT, LOCK 1/2-13
22	2	8041686	GROMMET 1"ID- 1 1/4"DOG-1/4"WO
23	2	8030486	WATER QD 1/4 MNPT SS
24	1	T401100	ELBOW 4MP 4MJ 90
25	1	T320030	FITTING, HOSE 4HO 4FJ
26	1	8043389	ADAPTER M2" F THREAD
27	1	8030526	FITTING, QD WATER 1/4"F-1/4"FP
28	1	T320300	FITTING, HOSE 4HO 4MP
29	1	8044108	HOSE VAC SURFACE CLEANER
30	1	8043392	ADAPTER M2" F THREAD
31	1	8043391	REDUCER COUPLER 2"F 90 DEG - 3"M
32	1	8043395	REDUCER COUPLER 2" X 3" ADAPTER
33	1	8043398	HOSE VAC CLEAR 2"
*	2	8043397	CLAMP VAC CLEAR HOSE 2"
*	4	U360020	PIN, U-LOCK 3/8 X 1.5

**PAGE LEFT BLANK**

# 31LEG ELECTRICAL SCHEMATIC

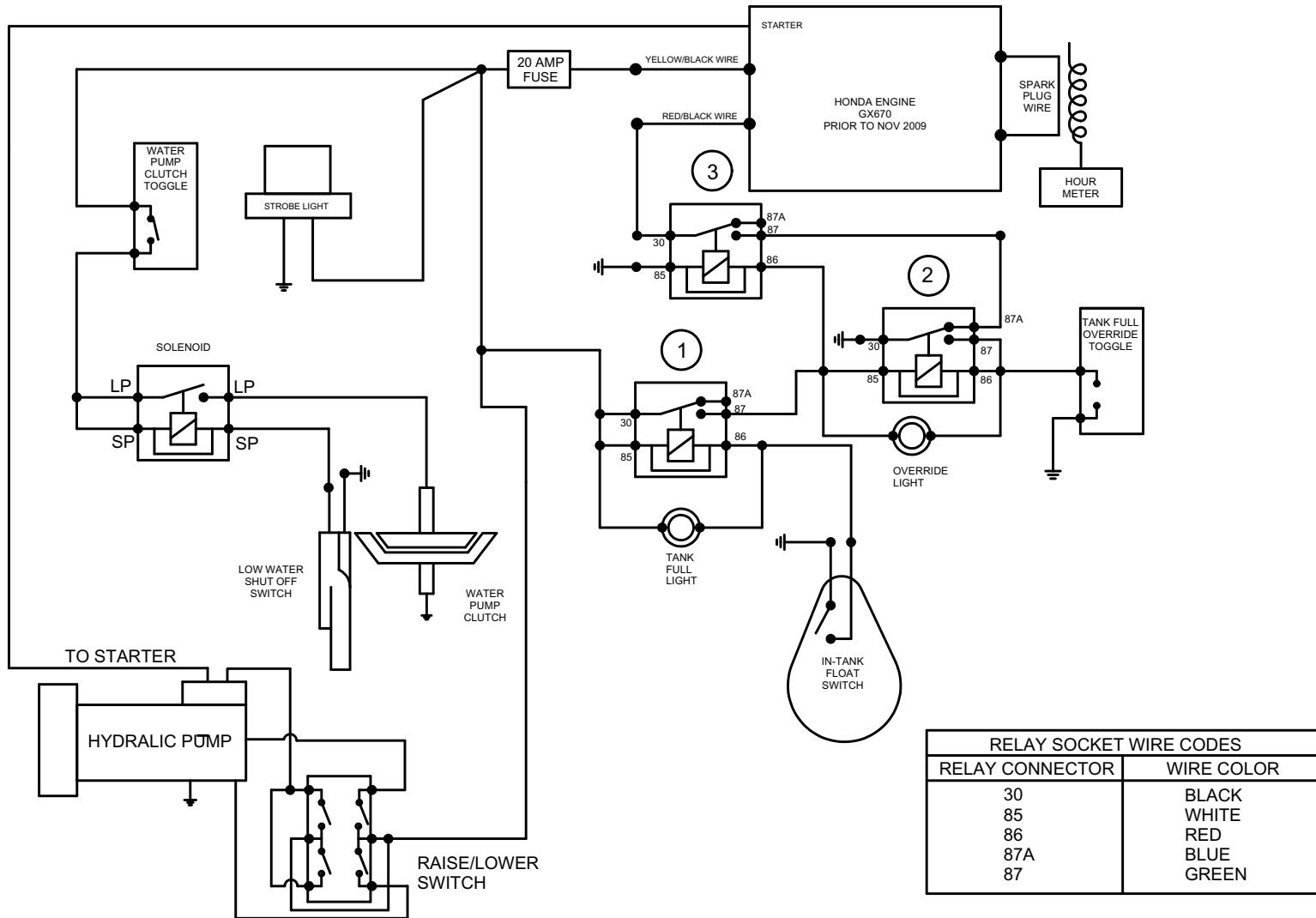

# TANK AND OPTIONAL JACK HYDRAULIC SCHEMATIC (2-Stage)

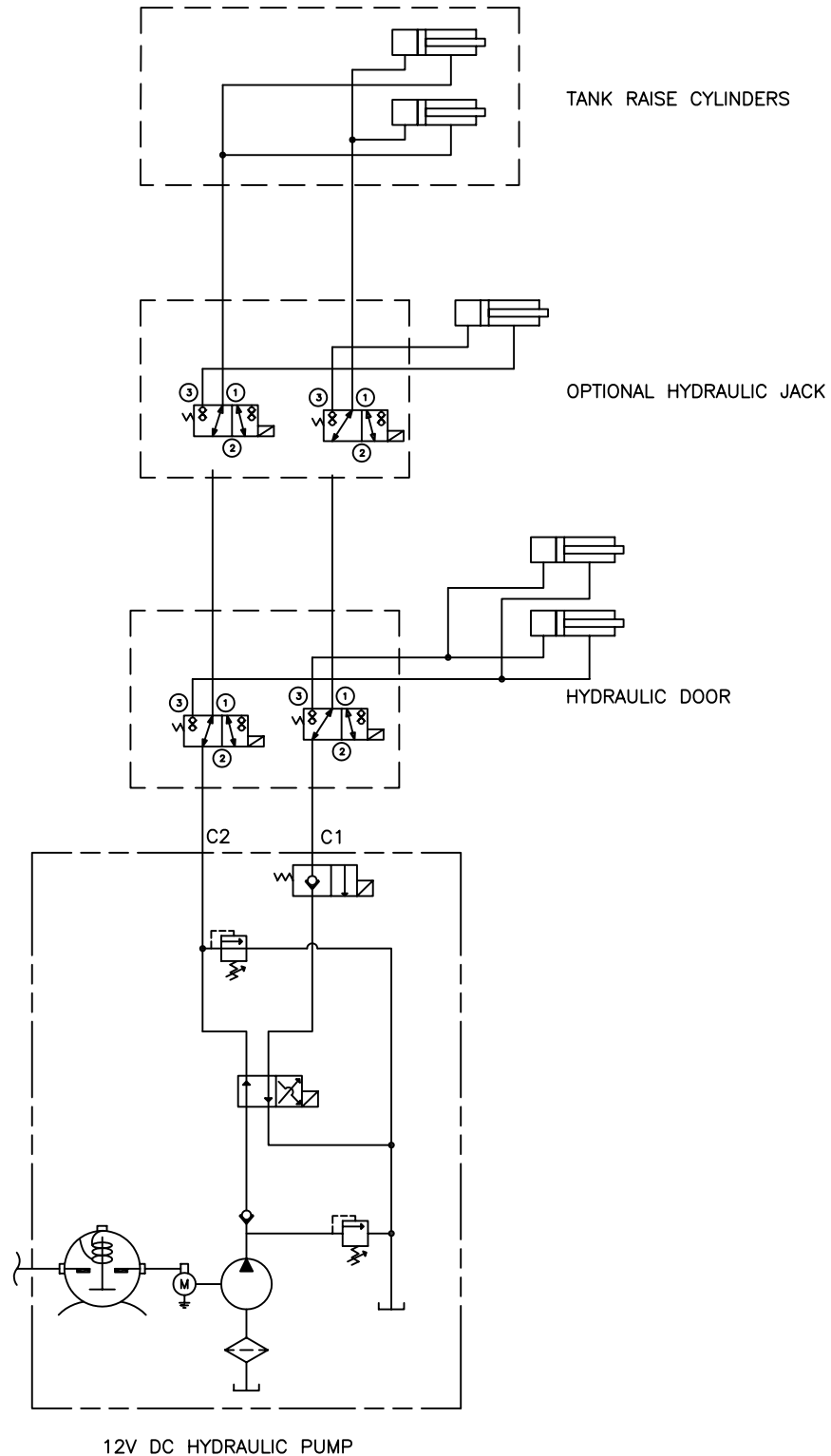

051410-E



**PAGE LEFT BLANK**

# ROOTS

Blowers Compressors Exhausters

## Universal URAI-DSL

### Contents

---

Information Summary	Troubleshooting
Safety Precautions	Inspection & Maintenance
Operating Limitations	Data
Lubrication	Assembly Drawings
Operation	Parts List

### Do These Things To Get The Most From Your ROOTS™ blower

---

- **Make sure both driving and driven equipment is correctly lubricated before start-up. See LUBRICATION.**
- In event of trouble during installation or operation, do not attempt repairs of ROOTS furnished equipment. Notify ROOTS, giving all nameplate information plus an outline of operating conditions and a description of the trouble. Unauthorized attempts at equipment repair may void ROOTS warranty.
- Units out of warranty may be repaired or adjusted by the owner. Good inspection and maintenance practices should reduce the needs for repairs.

**NOTE:** Information in this manual is correct as of the date of publication. ROOTS reserves the right to make design or material changes without notice, and without obligation to make similar changes without notice, and without obligation to make similar changes on equipment of prior manufacture.

## Safety Precautions

It is important that all personnel observe safety precautions to minimize the chances of injury. Among many considerations, the following should be particularly noted:

- Blower casing and associated piping or accessories may become hot enough to cause major skin burns on contact.
- Internal and external rotating parts of the blower and driving equipment can produce serious physical injuries. Do not reach into any opening in the blower while it is operating, or while subject to accidental starting. Protect external moving parts with adequate guards.
- Disconnect power before doing any work, and avoid bypassing or rendering inoperative any safety or protective devices.
- If blower is operated with piping disconnected, place a strong coarse screen over the inlet and avoid standing in the discharge air stream. **CAUTION: Never cover the blower inlet with your hand or other part of body.**
- Stay clear of the blast from pressure relief valves and the suction area of vacuum relief valves.
- Use proper care and good procedures in handling, lifting, installing, operating and maintaining the equipment.
- Casing pressure must not exceed 25 PSI (1725 mbar) gauge. Do not pressurize vented cavities from an external source, nor restrict the vents without first consulting Roots.
- Do not use air blowers on explosive or hazardous gases.
- Other potential hazards to safety may also be associated with operation of this equipment. All personnel working in or passing through the area should be trained to exercise adequate general safety precautions.

## Operating Limitations

A ROOTS blower or exhauster must be operated within certain approved limiting conditions to enable continued satisfactory performance. Warranty is contingent on such operation.

Maximum limits for pressure, temperature and speed are specified in TABLE 1 for various models & sizes of blowers & exhausters. These limits apply to all units of normal construction, when operated under standard atmospheric conditions. Be sure to arrange connections or taps for instruments, thermometers and pressure or vacuum gauges at or near the inlet and discharge connections of the unit. These, along with a tachometer, will enable periodic checks of operating conditions.

**PRESSURE** – The pressure rise, between inlet and discharge, must not exceed the figure listed for the specific unit frame size concerned. Also, in any system where the unit inlet is at a positive pressure above atmosphere a maximum case rating of 25 PSI gauge (1725 mbar) should not be exceeded without first consulting Roots. Never should the maximum allowable differential pressure be exceeded.

On vacuum service, with the discharge to atmospheric pressure, the inlet suction or vacuum must not be greater than values listed for the specific frame size.

**TEMPERATURE** – Blower & exhauster frame sizes are approved only for installations where the following temperature limitations can be maintained in service:

- Measured temperature rise must not exceed listed values when the inlet is at ambient temperature. Ambient is considered as the general temperature of the space around the unit. This is not outdoor temperature unless the unit is installed outdoors.
- If inlet temperature is higher than ambient, the listed allowable temperature rise values must be reduced by 2/3 of the difference between the actual measured inlet temperature and the ambient temperature.
- The average of the inlet and discharge temperature must not exceed 250°F. (121°C).
- The ambient temperature of the space the blower/motor is installed in should not be higher than 120°F (48.8°C).

**SPEED** – These blowers & exhausters may be operated at speeds up to the maximum listed for the various frame sizes. They may be direct coupled to suitable constant speed drivers if pressure/temperature conditions are also within limits. At low speeds, excessive temperature rise may be a limiting factor.

**Special Note:** The listed maximum allowable temperature rise for any particular blower & exhauster may occur well before its maximum pressure or vacuum rating is reached. This may occur at high altitude, low vacuum or at very low speed. The units' operating limit is always determined by the maximum rating reached first. It can be any one of the three: Pressure, Temperature or Speed.

## Lubrication

### For Units with Splash Lubrication on Both Ends

Bearings and oil seals are lubricated by the action of the timing gears or oil slingers which dip into the main oil sumps

causing oil to splash directly on gears and into bearings and seals. A drain port is provided below each bearing to prevent an excessive amount of oil in the bearings. Seals located inboard of the bearings in each headplate effectively retain oil within the sumps. Any small leakage that may occur should the seals wear passes into a cavity in each vented headplate and is drained downward.

Oil sumps on each end of the blower are filled by removing top vent plugs, Item (25), and filling until oil reaches the middle of the oil level sight gauge when the unit is not operating, Item (45 or 53), DO NOT FILL PAST THE MIDDLE OF THE SIGHT GLASS.

Initial filling of the sumps should be accomplished with the blower not operating, in order to obtain the correct oil level. Approximate oil quantities required for blowers of the various models and configurations are listed in Table 3. Use a good grade of industrial type non-detergent, rust inhibiting, anti-foaming oil and of correct viscosity per Table 2. **\*ROOTS synthetic oil (Roots P/N 813-106-) is specified and recommended.** Roots does not recommend automotive type lubricants, as they are not formulated with the properties mentioned above.

The oil level may rise or fall on the gauge during operation, to an extent depending somewhat on oil temperature and blower speed.

Proper lubrication is usually the most important single consideration in obtaining maximum service life and satisfactory operation from the unit. Unless operating conditions are quite severe, a weekly check of oil level and necessary addition of lubricant should be sufficient. During the first week of operation, check the oil levels in the oil sumps about once a day, and watch for leaks. Replenish as necessary. Thereafter, an occasional check should be sufficient. It is recommended that the oil be changed after initial 100 hours of operation. Frequent oil changing is not necessary unless the blower is operated in a very dusty location.

Normal life expectancy of petroleum based oils is about 2000 hours with an oil temperature of about 180°F (82°C). As the oil temperature increases by increments of 15-18°F (8°C - 10°C), the life is reduced by half. Example: Oil temperatures of 210-216°F (99°C - 102°C) will produce life expectancy of 1/4 or 500 hours. Therefore, it is considered normal to have oil change periods of 500 hours with petroleum based oils.

Normal life expectancy of ROOTS™ Synthetic Oil is about 4000 to 8000 hours with an oil temperature of about 180°F (82°C). As the oil temperature increases by increments of 15-18°F (8°C - 10°C), the life is reduced by half. Example: Oil temperatures of 210-216°F (99°C - 102°C) will produce life expectancy of 1/4 or 1000 to 2000 hours.

NOTE: To estimate oil temperature, multiply the discharge temperature of the blower by 0.80. Example: if the discharge air temperature of the blower is 200° F, it is estimated that the oil temperature is 160° F.

\*ROOTS™ Synthetic Oil & Grease is superior in performance to petroleum based products. It has high oxidation stability, excellent corrosion protection, extremely high film strength and low coefficient of friction. Typical oil change intervals are increased 2-3 times over petroleum based lubricants. Also, ROOTS™ Synthetic Oil is 100% compatible with petroleum based oils. Simply drain the oil in the blower and refill the reservoirs with ROOTS™ Synthetic Oil to maintain optimum performance of your ROOTS™ blower.

## Operation

Before operating a blower under power for the first time, recheck the unit and the installation thoroughly to reduce the likelihood of avoidable troubles. Use the following procedure check list as a guide, but consider any other special conditions in the installation.

- Be certain that no bolts, tools, rags, or debris have been left in the blower air chamber or piping.
- If an outdoor intake without filter is used, be sure the opening is located so it cannot pick up dirt and is protected by a strong screen or grille. Use of the temporary protective screen as described under INSTALLATION is strongly recommended.
- Recheck blower leveling, drive alignment and tightness of all mounting bolts if installation is not recent. If belt drive is used, adjust belt tension correctly.
- Turn drive shaft by hand to make sure impellers still rotate without bumping or rubbing at any point.
- Ensure oil levels in the main oil sumps are correct.
- Check lubrication of driver. If it is an electric motor, be sure that power is available and that electrical overload devices are installed and workable.
- Open the manual unloading valve in the discharge air line. If a valve is in the inlet piping, be sure it is open.
- Bump blower a few revolutions with driver to check that direction of rotation agrees with arrow near blower shaft, and that both coast freely to a stop.

After the preceding points are cleared, blower is ready for trial operation under "no-load" conditions. The following procedure is suggested to cover this initial operation test period.

- a. Start blower, let it accelerate to full speed, then shut off. Listen for knocking sounds, both with power on and as speed slows down.
- b. After blower comes to a complete stop, repeat above, but let blower run 2 or 3 minutes. Check for noises, such as knocking sounds.
- c. After blower comes to a complete stop, operate blower for about 10 minutes unloaded. Check oil levels. Observe cylinder and headplate surfaces for development of hot spots such as burned paint, indicating impeller rubs. Be aware of any noticeable increase in vibration.

Assuming that all trials have been satisfactory, or that necessary corrections have been made, the blower should now have a final check run of at least one hour under normal operating conditions. After blower is restarted, gradually

close the discharge unloading valve to apply working pressure. At this point it is recommended that a pressure gauge or manometer be connected into the discharge line if not already provided, and that thermometers be in both inlet and discharge lines. Readings from these instruments will show whether pressure or temperature ratings of the blower are being exceeded.

During the final run, check operating conditions frequently and observe the oil levels at reasonable intervals. If excessive noise or local heating develops, shut down immediately and determine the cause. If either pressure rise or temperature rise across the blower exceeds the limit specified in this manual, shut down and investigate conditions in the piping system. Refer to the TROUBLESHOOTING CHECKLIST for suggestions on various problems that may appear.

The blower should now be ready for continuous duty operation at full load. During the first few days make periodic checks to determine whether all conditions remain steady, or at least acceptable. This may be particularly important if the blower is supplying air to a process system where conditions can vary. At the first opportunity, stop the blower and clean the temporary inlet protective screen. If no appreciable amount of debris has collected, the screen may be removed. See comments under INSTALLATION. At this same time, verify leveling, coupling alignment or belt tension, and mounting bolt tightness.

Should operating experience prove that blower capacity is a little too high for the actual air requirements, a small excess may be blown off continuously through the manual unloading or vent valve. Never rely on the pressure relief valve as an automatic vent. Such use may cause the discharge pressure to become excessive, and can also result in failure of the valve itself. If blower capacity appears to be too low, refer to the TROUBLESHOOTING CHECKLIST.

### Vibration Assessment Criteria

With measurements taken at the bearing locations on the housings, see chart below for an appropriate assessment guide for rotary lobe blowers rigidly mounted on stiff foundations.

In general, blower vibration levels should be monitored on a regular basis and the vibration trend observed for progressive or sudden change in level. If such a change occurs, the cause should be determined through spectral analysis.

As shown on the chart below, the level of all pass vibration will determine the need to measure discrete frequency vibration levels and the action required.

All Pass Vibration (in/sec)	Discrete Frequency Vibration (in/sec)	Action
0.45 or less	N/R	Acceptable
Greater than 0.45 but 1.0 or less	0.45 or less @ any frequency	Acceptable
	Greater than 0.45 @ any frequency	Investigate
Greater than 1.0	Less than 1.0	Investigate
	Greater than 1.0	Investigate

## Troubleshooting Checklist

Trouble	Item	Possible Cause	Remedy
No flow	1	Speed too low	Check by tachometer and compare with published performance
	2	Wrong rotation	Compare actual rotation with Figure 1 Change driver if wrong
	3	Obstruction in piping	Check piping, valves, silencer to assure open flow path
Low capacity	4	Speed too low	See item 1, If belt drive, check for slippage and readjust tension
	5	Excessive pressure rise	Check inlet vacuum and discharge pressure and compare with Published performance
	6	Obstruction in piping	See item 3
	7	Excessive slip	Check inside of casing for worn or eroded surfaces causing excessive clearances
Excessive power	8	Speed too high	Check speed and compare with published performance
	9	Excessive pressure rise	See Item 5
	10	Impeller rubbing	Inspect outside of cylinder for high temperature areas, then check for impeller contact at these points. Correct blower mounting, drive alignment
	11	Scale, sludge, rust or product build up	Clean blower appropriately
Damage to bearings or gears	12	Inadequate lubrication	Check oil sump levels in gear and drive end headplates
	13	Excessive lubrication	Check oil levels. If correct, drain and refill with clean oil of recommended grade
	14	Excessive pressure rise	See Item 5
	15	Coupling misalignment	Check carefully. Realign if questionable
	16	Excessive belt tension	Readjust for correct tension
Vibration	17	Misalignment	See Item 15
	18	Impellers rubbing	See Item 10
	19	Worn bearings/gears	Check gear backlash and condition of bearings, and replace as indicated
	20	Unbalanced or rubbing impeller	Scale or process material may build up on casing and impellers, or inside impellers. Remove build-up to restore original clearances and impeller balance
	21	Driver or blower loose	Tighten mounting bolts securely
	22	Piping resonances	Determine whether standing wave pressure pulsations are present in the piping
	23	Scale/sludge build-ups	Clean out interior of impeller lobes to restore dynamic balance
Driver stops, or will not start	24	Casing strain	Re-work piping alignment to remove excess strain
	25	Impeller stuck	Check for excessive hot spot on headplate or cylinder. See item 10. Look for defective shaft bearing and/or gear teeth
	26	Scale, sludge, rust or product build-up	Clean blower appropriately
Excessive breather	27	Broken seal	Replace seals
Blow-by or excessive oil leakage to vent area	28	Defective O-ring	Replace seals and O-ring
Excessive oil leakage in vent area	29	Defective/plugged breather	Replace breather and monitor oil leakage
	30	Oil level too high	Check sump levels in gear and drive headplates.
	31	Oil type or viscosity incorrect	Check oil to insure it meets recommendations. Drain then fill with clean oil of recommended grade.
	32	Blower running hot	Check blower operating conditions to ensure they are within the operating limitations defined in this manual.

## Inspection & Maintenance: Universal RAI® series blowers

A good program of consistent inspection and maintenance is the most reliable method of minimizing repairs to a blower. A simple record of services and dates will help keep this work on a regular schedule. Basic service needs are:

- Lubrication
- Checking for hot spots
- Checking for increases or changes in vibration and noise
- Recording of operating pressures and temperatures

Above all, a blower must be operated within its specified rating limits, to obtain satisfactory service life.

A newly installed blower should be checked often during the first month of full-time operation. Attention there after may be less frequent assuming satisfactory performance.

Lubrication is normally the most important consideration and weekly checks of lubricant levels in the gearbox and bearing reservoirs should be customary. Complete oil change schedules are discussed under **LUBRICATION**.

Driver lubrication practices should be in accordance with the manufacturer's instructions. If direct connected to the blower through a lubricated type coupling, the coupling should be checked and greased each time blower oil is changed. This will help reduce wear and prevent unnecessary vibration. In a belted drive system, check belt tension periodically and inspect for frayed or cracked belts.

In a new, and properly installed, unit there is no contact between the two impellers, or between the impellers and cylinder or headplates. Wear is confined to the bearings (which support and locate the shafts) the oil seals, and the timing gears. All are lubricated and wear should be minimal if clean oil of the correct grade is always used. Seals are subject to deterioration as well as wear, and may require replacement at varying periods.

Shaft bearings are designed for optimum life under average conditions with proper lubrication and are critical to the service life of the blower. Gradual bearing wear may allow a shaft position to change slightly, until rubbing develops between impeller and casing. This will cause spot heating, which can be detected by observing these surfaces. Sudden bearing failure is usually more serious. Since the shaft and impeller are no longer supported and properly located, extensive general damage to the blower casing and gears is likely to occur.

Oil seals should be considered expendable items, to be replaced whenever drainage from the headplate vent cavity becomes excessive or when the blower is disassembled for

any reason. Some oil seal leakage may occur since an oil film under the lip is required for proper operation. Periodically leaked oil should be wiped off from surfaces. Minor seal leakage should not be considered as indicating seal replacement.

Timing gear wear, when correct lubrication is maintained, should be negligible. Gear teeth are cut to provide the correct amount of backlash, and gears correctly mounted on the shafts will accommodate a normal amount of tooth wear without permitting contact between lobes of the two impellers. However, too high an oil level will cause churning and excessive heating. This is indicated by unusually high temperature at the bottom of the gear housing. Consequent heating of the gears will result in loss of tooth-clearance, backlash and rapid wear of the gear teeth usually will develop. Continuation of this tooth wear will eventually produce impeller contacts (knocking), and from this point serious damage will be unavoidable if blower operation is continued. A similar situation can be produced suddenly by gear tooth fracture, which is usually brought on by sustained overloading or momentary shock loads.

Problems may also develop from causes other than internal parts failure. Operating clearances within a blower are only a few thousandths of an inch. This makes it possible for impeller interference or casing rubs to result from shifts in the blower mounting, or from changes in piping support. If this type of trouble is experienced, and the blower is found to be clean, try removing mounting strains. Loosen blower mounting bolts and reset the leveling and drive alignment. Then tighten mounting again, and make sure that all piping meets blower connections accurately and squarely. Foreign materials in the blower will also cause trouble, which can only be cured by disconnecting the piping and thoroughly cleaning the blower interior.

A wide range of causes & solutions for operating troubles are covered in the **TROUBLE SHOOTING CHECKLIST**. The remedies suggested should be performed by qualified mechanics with a good background. Major repairs generally are to be considered beyond the scope of maintenance, and should be referred to an authorized Roots distributor.

Warranty failures should not be repaired at all, unless specific approval has been obtained through Roots before starting work. Unauthorized disassembly within the warranty period may void the warranty.

Figure 2 - Allowable Overhung Loads for V-Belt Drives Universal RAI®/URAI®-DSL Units

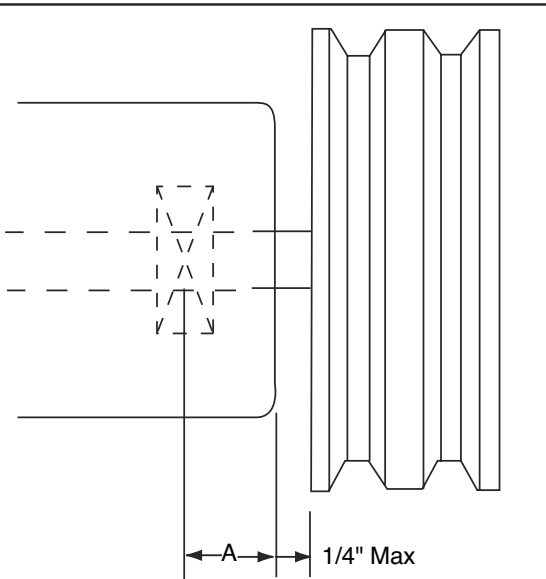

$$\text{Belt Pull lbs} = \frac{252100 \cdot \text{Motor HP}}{\text{Blower RPM} \cdot \text{Sheave Diameter}}$$

$$\text{Shaft Load (lb.in)} = \text{Belt Pull} \cdot \left( A + \frac{1}{4} + \frac{\text{Sheave Width}}{2} \right)$$

Frame Size	Dimension "A"	Max Allowable Shaft Load (lb-in)	Min Sheave Diameter
47	1.02	650	5.00

**NOTE:**

Arc of sheave belt contact on the smaller sheave not to be less than 170°  
 Driver to be installed on the inlet side for vertical units, and on the drive shaft side for horizontal units.  
 Roots recommends the use of two or more 3V, 5V or 8V matched set or banded belts and sheaves.

**Specified Lubricants**

**ROOTS Synthetic Oil: ISO-VG-320 Grade**

	Part Number
Quart	13106004
Gallon	13106005
Case (12 qts)	13106007

**ROOTS Synthetic Oil: ISO-VG-220 Grade**

	Part Number
Quart	13106001
Gallon	13106002
Case (12 qts)	13106008

**ROOTS Synthetic Oil: ISO-VG-150 Grade**

	Part Number
Quart	13106020
Gallon	13106021
Case (12 qts)	13106023
5 Gallon Pail	13106022
55 Gallon Drum	13106025



**Drive End Breather Orientation for URA-DSL blowers with Oil Lube**

BREATHER LOCATION  
BREATHER LOCATION

DRIVE SHAFT  
ANY LOCATION

HORIZONTAL

VERTICAL

**URAI DSL BREATHER ORIENTATION**

**Table 1 - URAI, URAI-DSL Blowers,  
Maximum Allowable Operating Conditions**

<b>Frame Size</b>	<b>Gear Diameter (Inch)</b>	<b>Speed RPM</b>	<b>Temp. Rise Deg F (Deg C)</b>	<b>Delta Pressure PSI (mbar)</b>	<b>Inlet Vacuum INHG (mbar)</b>
47	4	3,600	225 (125)	7 (483)	15 (500)

**Table 2 - Recommended Oil Grades**

Ambient Temperature °F (°C)	ISO Viscosity No.
Above 90° (32°)	320
32° to 90° (0° to 32°)	220
0° to 32° (-18° to 0°)	150
Below 0° (-18°)	100

Ambient temperature is defined as the temperature of the space in which the blower and drive are located.

**Table 3 - Approximate Oil Sump Capacities**

These capacities are provided to assist in stocking the correct amount of oil. Exact sump capacities may differ slightly. See "Lubrication" section for proper filling instructions.

**URAI-DSL Splash Lubricated Blowers**

Frame Size	Gear End Capacity Fl. Oz (Liters)	Drive End Capacity Fl. Oz. (Liters)
47	22.8 (.67)	10.8 (.32)

Basic Connection & Drive Shaft Information

**URAI DSL AIR BLOWERS (with Dual Splash Lubrication DSL)**

BOM#	FRAME SIZE	INLET/DISCHARGE CONN.	SHAFT DIAMETER	BARE WEIGHT
T30354020	47	3" NPT	.0875"	132

Universal RAI air blowers include detachable mounting feet which permit vertical or horizontal installation. The units are center timed for rotation in either direction. The bearings on the URAI are grease lubricated on the drive end and splash lubricated on the gear end. The URAI-DSL is splash lubricated on BOTH ends.

**PAGE LEFT BLANK**

**PAGE LEFT BLANK**

# **WARRANTY RETURN GOODS POLICY**

## **LIMITED WARRANTY**

The Manufacturer warrants its products to be free from defects in material and workmanship for a period of twelve months from the date of shipment from the factory. The Manufacturer shall not be responsible for any damage resulting to or caused by its products by reason of installation, improper storage, unauthorized service, alteration of the products, neglect or abuse, or use of the product in a manner inconsistent with its design. The warranty does not extend to any component parts not manufactured by Manufacturer; however, Manufacturer's warranty herein shall not limit any warranties made by manufacturers of component parts which extend to Buyer.

Claims for defects in material and workmanship shall be made in writing to Manufacturer within ten days of discovery of defect. Manufacturer may either send a service representative or have the product returned to its factory at Buyer's expense for inspection. Upon notification of defect, Manufacturer will issue a return goods authorization number to Buyer. The return goods authorization number must accompany the product returned. If judged by the Manufacturer to be defective in material or workmanship, the product will be replaced or repaired at the option of the Manufacturer, free from all charges except authorized transportation. Buyer shall be responsible for all maintenance services consisting of lubrication and cleaning of equipment, replacing expandable parts making minor adjustments, and performing operating checks, all in accordance with procedures outlined in Manufacturer's maintenance literature.

THE FOREGOING WARRANTY IS IN LIEU OF ALL OTHER WARRANTIES AND NO REPRESENTATIONS, GUARANTEES, OR WARRANTIES, EXPRESS OR IMPLIED, (INCLUDING BUT NOT LIMITED TO A WARRANTY OF MERCHANTABILITY OR FITNESS FOR A PARTICULAR PURPOSE), ARE MADE BY THE MANUFACTURER IN CONNECTION WITH THE MANUFACTURE OR SALE OF ITS PRODUCTS. NO EMPLOYEE, DISTRIBUTOR, OR REPRESENTATIVE IS AUTHORIZED TO CHANGE THIS WARRANTY ON BEHALF OF MANUFACTURER. THE REMEDIES OF BUYER SET FORTH HEREIN ARE EXCLUSIVE AND ARE IN LIEU OF ALL OTHER REMEDIES. THE LIABILITY OF MANUFACTURER WHETHER IN CONTRACT, TORT, UNDER ANY WARRANTY, OR OTHERWISE SHALL NOT EXTEND BEYOND ITS OBLIGATION TO REPAIR OR REPLACE, AT ITS OPTION ANY PRODUCT OR PART FOUND BY MANUFACTURER TO BE DEFECTIVE IN MATERIAL OR WORKMANSHIP. MANUFACTURER SHALL NOT BE LIABLE FOR COST OF INSTALLATION AND/OR REMOVAL OR BE RESPONSIBLE FOR DIRECT, INDIRECT, SPECIAL OR CONSEQUENTIAL DAMAGES OF ANY NATURE.

## **GENERAL RETURNS OF MERCHANDISE**

1. All returns must be pre-authorized
  - A. Please call our parts department for an RGA number
  - B. Please include RGA number on the outside of box
  - C. Include any required paper work or special instructions
  - D. Items returned without an RGA number will not be accepted
2. All returns are subject to a 20% restock charge.
3. Special items are non-returnable
  - A. Non-stock parts
  - B. Custom parts
  - C. If you are unsure about a parts status when ordering, ask your McLaughlin representative if the item fits on of the above conditions.
4. Items must be returned within thirty days of original order date.
5. Items not returned within 30 days from the date of RGA is issued will not be accepted.
6. The item(s) must be in new condition. Used item(s) are not returnable.



