



Providing Solutions Since 1921

2006 Perimeter Road. Greenville, SC 29605

Toll Free: 800/435-9340 – Phone: 864/277-5870

Fax: 864/235-9661 – Website address: www.mclaughlinunderground

Email address: mmole@mightymole.com

PARTS MANUAL

VSK200-1600

E850619

SERIAL NUMBER V2001002193393 TO PRESENT

10/10/2019

2019 by McLaughlin Group, Inc. REV. 2

All rights reserved. No part of this manual may be reproduced in any form, or by any means without prior written permission of McLaughlin Group, Inc.

Table of Contents

DECAL LAYOUT	7
SKID ASSEMBLY.....	14
REMOTE DRAIN ASSEMBLY.....	18
ANTIFREEZE ASSEMBLY.....	20
ENCLOSURE ASSEMBLY	22
CONTROL BOX ASSEMBLY.....	24
ENGINE ASSEMBLY	26
BLOWER ASSEMBLY.....	28
WATER PUMP ASSEMBLY.....	30
HYDRAULIC PUMP ASSEMBLY.....	32
TANK & DOOR ASSEMBLY.....	34
HYDRAULIC ARM ASSEMBLY.....	36
FILTRATION ASSEMBLY	38
WATER TANK ASSEMBLY.....	40
WATER REEL ASSEMBLY.....	44
VAC TOOLS ASSEMBLY.....	46
BOOM TURRET ASSEMBLY.....	49
BOOM PIVOT ARM ASSEMBLY.....	50
BOOM EXTENSION ARM ASSEMBLY.....	51
HOTBOX ASSEMBLY	53

SYSTEM OPERATIONS SPECIFICATIONS

Part	Part #	First 50 hrs	Every 500 hrs	AS REQUIRED
Engine Oil	10W30 ACEA E9	✓Daily		
Engine Coolant	40/60 mixture of PROPYLENE GLYCOL AND WATER (must meet ASTM D6210 specifications)	✓Daily		X
Oil Filter (John Deere)	8092260-05	✓Daily	X	
Fuel Filter (primary) (John Deere)	8092260-02	✓Daily	X	
Air Filter (element) (John Deere)	8092260-22	✓Daily		X
Fuel-Water Separator Filter	8092260-01	X		
Hydraulic Oil	Industrial Type Hydraulic Fluid	✓Daily		
Water Pump Oil	General Pump Series 100 Oil or SAE30, Non- Detergent, Motor oil	✓Daily		
Blower Oil	Industrial Type, Heavy Duty, Non-Detergent Motor Oil	✓Daily, X		

HYDRAULIC TEMPERTURE RANGE	0-120°F (-18°-40°C) SAE 10 GRADE HYDRAULIC OIL or DEXTRON II ATF 32-175°F (0-80°C) SAE 20 GRADE HYDRAULIC OIL 3QTS (2.8L)
---------------------------------------	--

BLOWER TEMPERTURE RANGE	0°F (-1°C) AND UNDER SAE 20 30-90°F (-1-32°C) SAE 30 90°F (32°C) AND ABOVE SAE 40
------------------------------------	---

******WATER PUMP – (Remove fill cap and fill crankcase to dot on oil gauge window.)**

******Refer to Component Manual specific Component Specifications.**

GREASE GUN LUBE POINTS

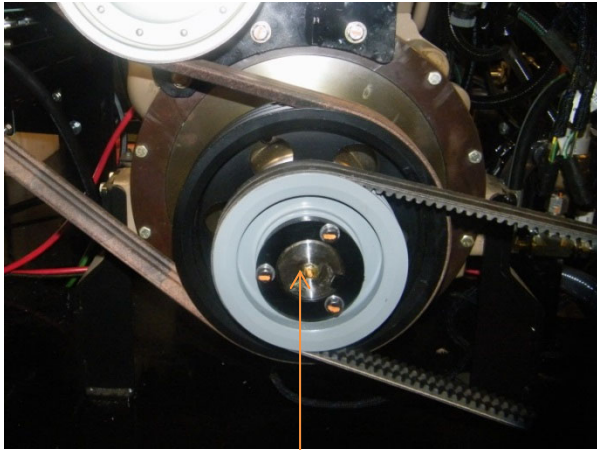

ENGINE GREASE POINT

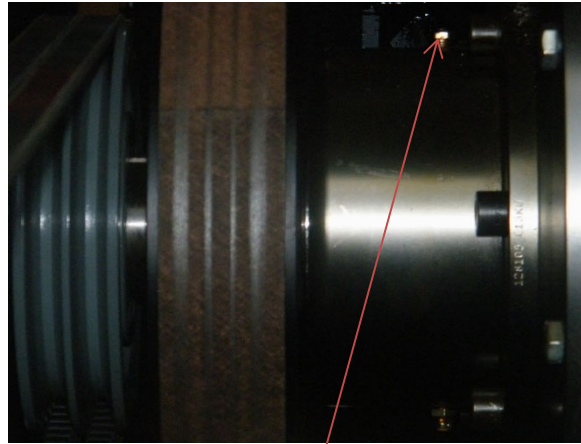

ENGINE HUB GREASE POINT



TANK PIVOT TUBE GREASE POINT

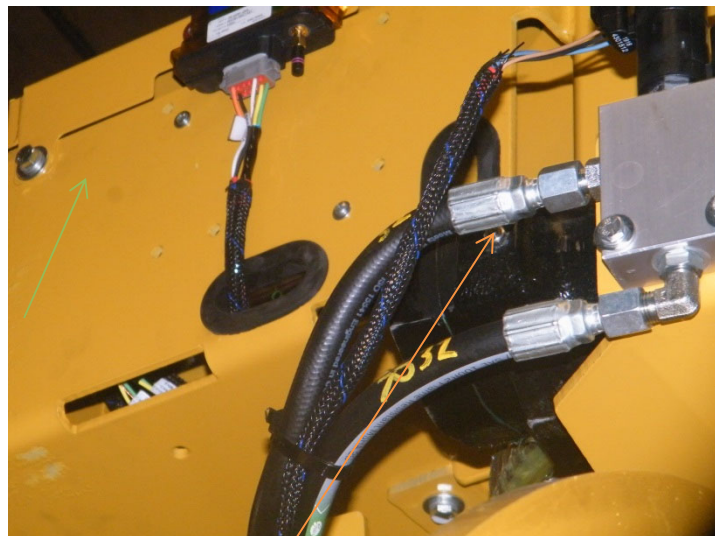

BOOM GREASE POINT

⚠ WARNING



ENTANGLEMENT HAZARD
Rotating pulleys and belts could cause serious injury.
Do not operate without guards in place.

J200445

J200445

⚠ WARNING

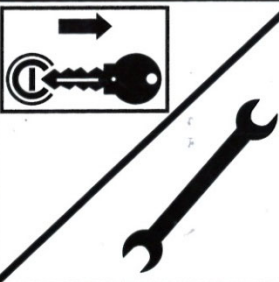

Moving parts.
Death or serious injury may result.
Stop engine before servicing.

J200425

J200425



	<p>⚠ WARNING</p> <p>Flammable fumes. Fumes may explode or catch fire. Keep away from sparks and open flame.</p>
	<p>Battery acid. Battery acid can burn skin and eyes. Protect face, hands and body when servicing.</p>

J200430

⚠ WARNING

Electricity, or Gas
Explosion Can Kill

Locate Utilities
Call 811

J200210

⚠ WARNING

Read manual.
Death or serious injury may result.
Read and understand
all safety and operating instructions
BEFORE operating any equipment.

J200420

J200420

⚠ WARNING

Hot fluid
under pressure.
Hot coolant and steam
can burn or scald.
NEVER open when hot.

J200435



⚠ WARNING

ENTANGLEMENT HAZARD
Rotating pulleys and belts
could cause serious injury.
Do not operate
without guards in place.

J200445

J200445

INSTRUCTIONS

DUMP PROCEDURE HYDRAULIC DOOR

1. Open gate valve on tank inlet - tank will not build vacuum
2. Click FULL TANK OVERRIDE switch to ON position
3. Start engine
4. Open door gate valve to drain liquids
5. Hold DOOR OPEN switch to open door
6. Hold TANK RAISE switch to raise tank
7. After dumping, hold TANK LOWER switch down to lower tank and DOOR CLOSE switch to close door
8. Shut off engine

J200481

J200481

⚠ WARNING

Moving parts.
Death or serious injury
may result.
Stop engine
before servicing.

J200425

J200425

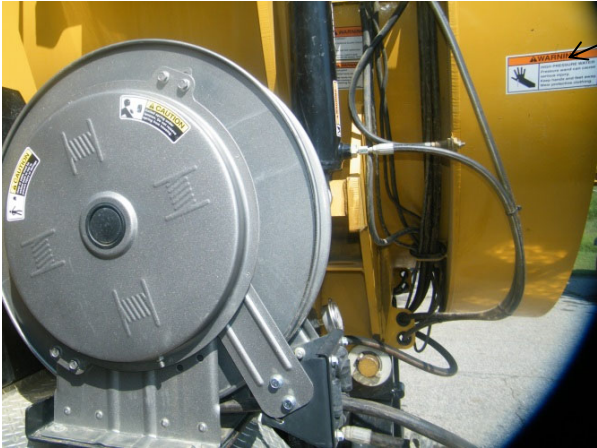

⚠ WARNING	
	<p>HIGH PRESSURE WATER Pressure wand can cause serious injury. Keep hands and feet away. Wear protective clothing.</p>

J200450



⚠ WARNING	
<p>Flammable liquid. Fuel and fumes can explode or catch fire. Turn off engine BEFORE fueling. Wipe up spilled fuel immediately.</p>	

J200440



	⚠ DANGER
	<p>CRUSH HAZARD.</p> <ul style="list-style-type: none"> • Moving clamp can crush and cut. • DO NOT operate with access cover removed.

J200411

⚠ DANGER	
<p>ELECTROCUTION HAZARD Death or serious injury will result if boom approaches or touches overhead electrical power lines. Keep boom away from overhead utilities. Use caution when operating boom.</p>	

J200403

DECAL LAYOUT



	WARNING
	<p>FIRE OR EXPLOSION POSSIBLE.</p> <p>Do not vacuum flammable or combustible substances.</p> <p style="text-align: right;"><small>J200473</small></p>

J200473

INSTRUCTIONS
<p style="text-align: center;">DUMP PROCEDURE HYDRAULIC DOOR</p> <ol style="list-style-type: none"> 1. Open gate valve on tank inlet - tank will not build vacuum 2. Click FULL TANK OVERRIDE switch to ON position 3. Start engine 4. Open door gate valve to drain liquids 5. Hold DOOR OPEN switch to open door 6. Hold TANK RAISE switch to raise tank 7. After dumping, hold TANK LOWER switch down to lower tank and DOOR CLOSE switch to close door 8. Shut off engine <p style="text-align: right;"><small>J200481</small></p>

J200481

DANGER

<p>EXPLOSION HAZARD! CONTENTS UNDER PRESSURE!</p> <p>Relieve tank pressure before opening.</p> <p>Failure to comply will result in death or serious injury.</p> <p style="text-align: right;"><small>J200423 rev.1</small></p>

J200423

DANGER

<p>Crushing weight.</p> <p>Spoil and door will cause death or serious injury.</p> <p>Unlock door only under vacuum.</p> <p>Stay away from door when dumping.</p>

J200410

	WARNING
	<p>Pinch point.</p> <p>Serious injury may result.</p> <p>Keep hands clear when closing door or lowering tank.</p> <p style="text-align: right;"><small>J200455</small></p>

J200455



DANGER

<p>SUFFOCATION HAZARD.</p> <p>Vacuum hoses will cause death or serious injury.</p> <p>Keep hoses and tools away from face and body.</p>

J200415

	WARNING
	<p>CRUSHING WEIGHT</p> <p>DEATH OR SERIOUS INJURY COULD RESULT</p> <p>EMPTY TANK BEFORE SERVICING</p> <p>ALWAYS INSTALL SAFETY BAR WHEN WORKING ON RAISED TANK</p> <p style="text-align: right;"><small>J200458</small></p>

J200458

PAGE LEFT BLANK

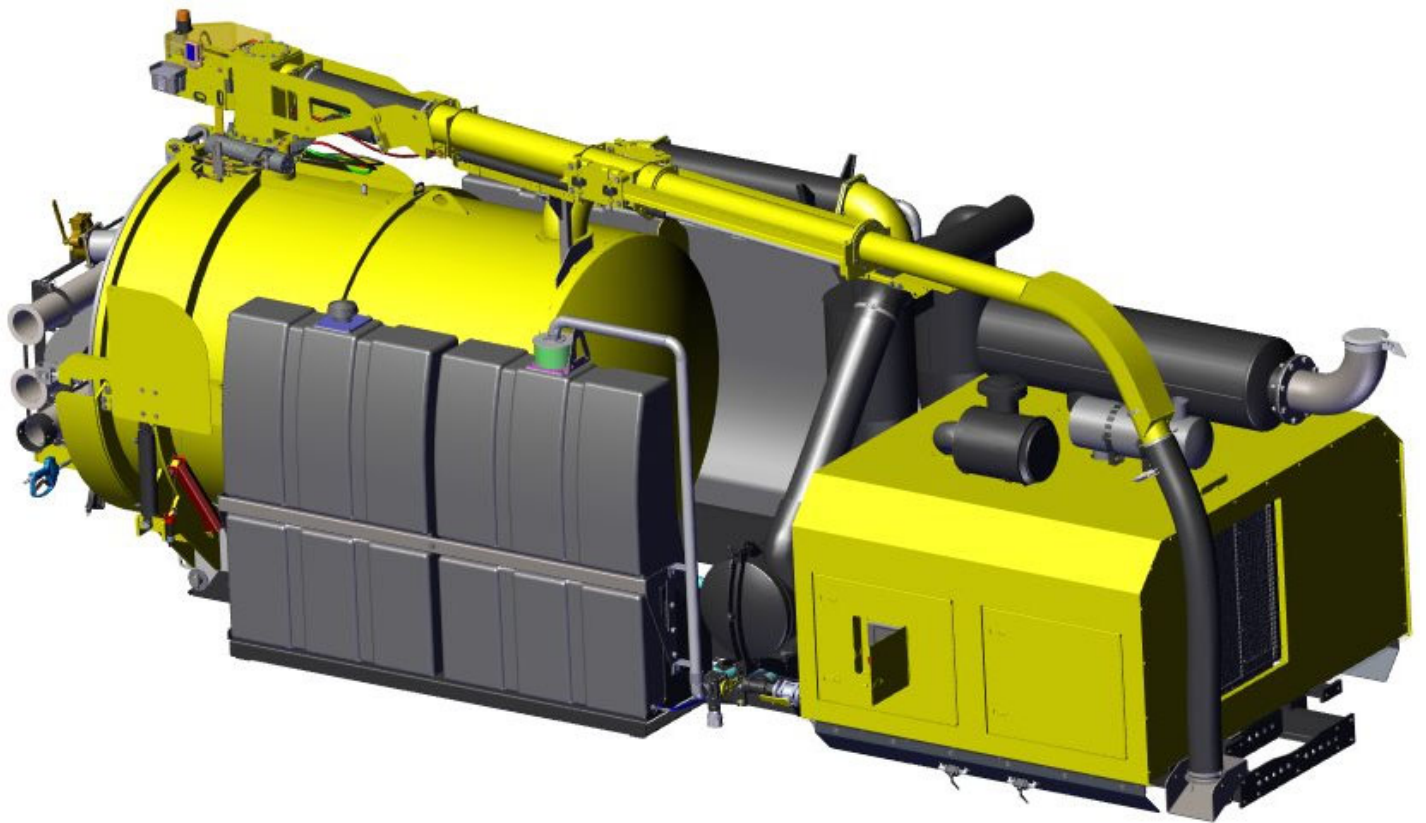

PAGE LEFT BLANK

VX200 SPOIL TANK SKID ASSEMBLY

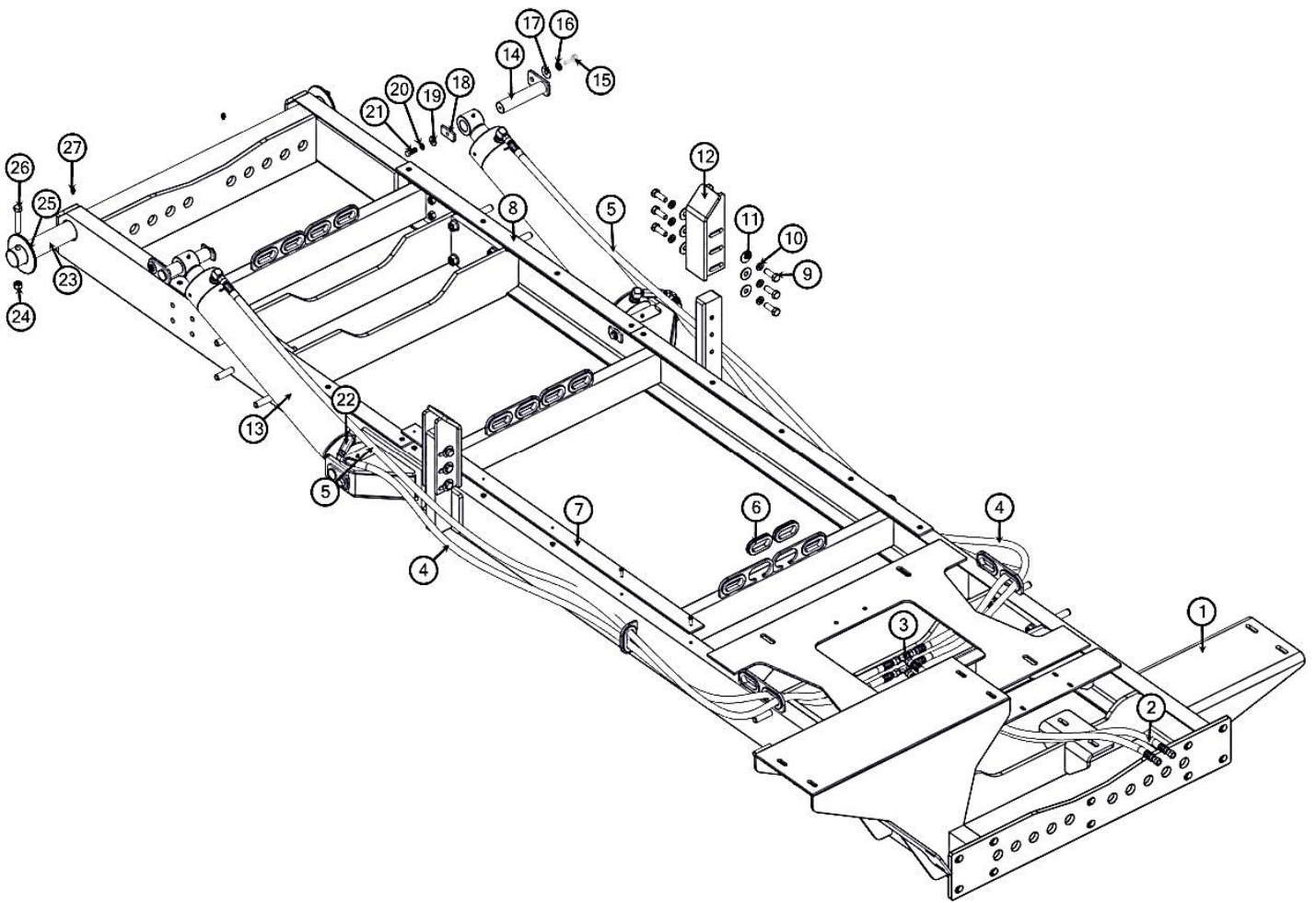

VX200 SPOIL TANK SKID ASSEMBLY

BOM ID	Qty	Name
1	1	8092682 WELDMENT, SKID (SPOIL) VX200
2	2	8045871 HOSE ASSY VAC 6-40" ST-ST
3	2	T402154 TEE, 6MJ-6MJ-6MJ
4	2	8046819 HOSE ASSY VAC 6-79" ST-90
5	2	8093486 HOSE ASSY VAC 6-110" ST-ST
6	18	8042812 GROMMET, 2"ID X 3"OD X 1/4"WOG
7	2	8093839 STRIP, PLASTIC SKID/TANK
8	2	8093840 STRIP, PLASTIC SKID/TANK 2
9	12	U000840 SCREW, HC .500-13 X 1.50 ZP G5
10	12	U210100 WASHER, LOCK .500 ZP
11	12	U200100 WASHER, FLAT .500 ZP
12	2	8092998 TANK GUIDE HEAVY WELDMENT
13	2	8044825 CYLINDER, HYD 4" X 20"
14	4	8094489 WELDMENT, TANK PIVOT PIN
15	4	U000820 SCREW, HC .500-13 X 1.25 ZP G5
16	4	U210100 WASHER, LOCK .500 ZP
17	4	U200100 WASHER, FLAT .500 ZP
18	4	8091173 PIN RETENTION PLATE
19	4	U200060 WASHER, FLAT .375 ZP
20	4	U210060 WASHER, LOCK .375 ZP
21	4	U000420 SCREW, HC .375-16 X 1.00 ZP G5
22	2	8048286 VALVE CHECK VELOCITY 6.0GPM
23	1	8092765 ROD, TANK PIVOT
24	2	U160018 NUT, LOCK .500-13 NY ZP
25	2	U200180 WASHER, FLAT 2.125"ID X 4.50"OD
26	2	U000930 SCREW, HC .500-13 X 3.00 ZP G5
27	2	T500030 FITTING, GREASE .125 NPT STR

VX200 POWERPACK SKID ASSEMBLY

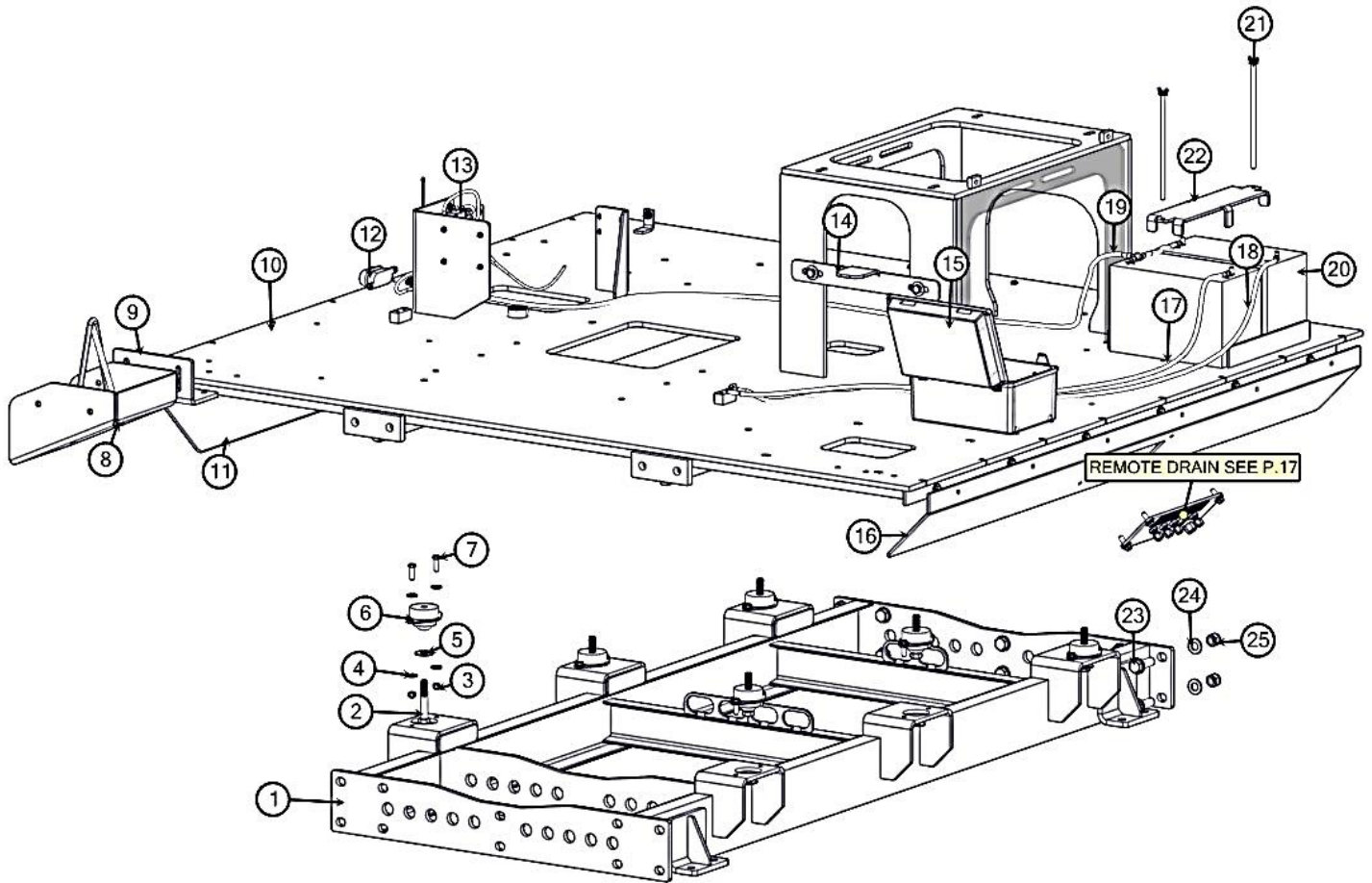

VX200 POWERPACK SKID ASSEMBLY

BOM ID	Qty	Name
1	1	8091957 SKID, POWERPACK VSK200
2	6	U001300 SCREW, HC .625-11 X 3.75 ZP G5
3	12	U120110 NUT, LOCK .375-16 NY ZP
4	24	U200060 WASHER, FLAT .375 ZP
5	12	U200140 WASHER, FLAT .625 ZP
6	6	8094547 ISOLATOR, 1200 LBS
7	12	U000440 SCREW, HC .375-16 X 1.25 ZP G5
8	1	8094634 HOSE STORAGE TRAY WELDMENT
9	1	8094630 HOSE STORAGE MOUNT BRACKET
10	1	8092201 MAIN PLATE WELDMENT VX200
11	1	8091965 ENCLOSURE SKIRT VX200
12	1	8043800 FUSE HOLDER AMG
13	1	X000030 RELAY, POWER SPST 75A DUAL CONT
14	1	8094280 MOUNT, PIPE 6"
15	1	8094271 TOOL BOX, ENCLOSURE
16	1	8092832 SKIRT DRAIN PANEL WELDMENT
17	1	X300341 CABLE, BATTERY GND 1GA 62" 3/8"-3/8"
18	1	X300340 CABLE, BATTERY GND 1GA 70" 3/8"-3/8"
19	1	X300345 CABLE, BATTERY HOT 1GA 95" 3/8"-3/8"
20	2	X400050 BATTERY, 31-MHD WORKAHOLIC
21	2	8043742 BATTERY ROD HOLD DOWN VK
22	1	8092857 DUAL BATTERY HOLD DOWN PLATE
23	10	U001425 SCREW, HC .750-10 X 2.50 ZP G8
24	20	U200165 WASHER, FLAT .750 ZP SAE HARD
25	10	U120041 NUT, LOCK NY .750-10 ZP G8

VX200 REMOTE DRAIN ASSEMBLY

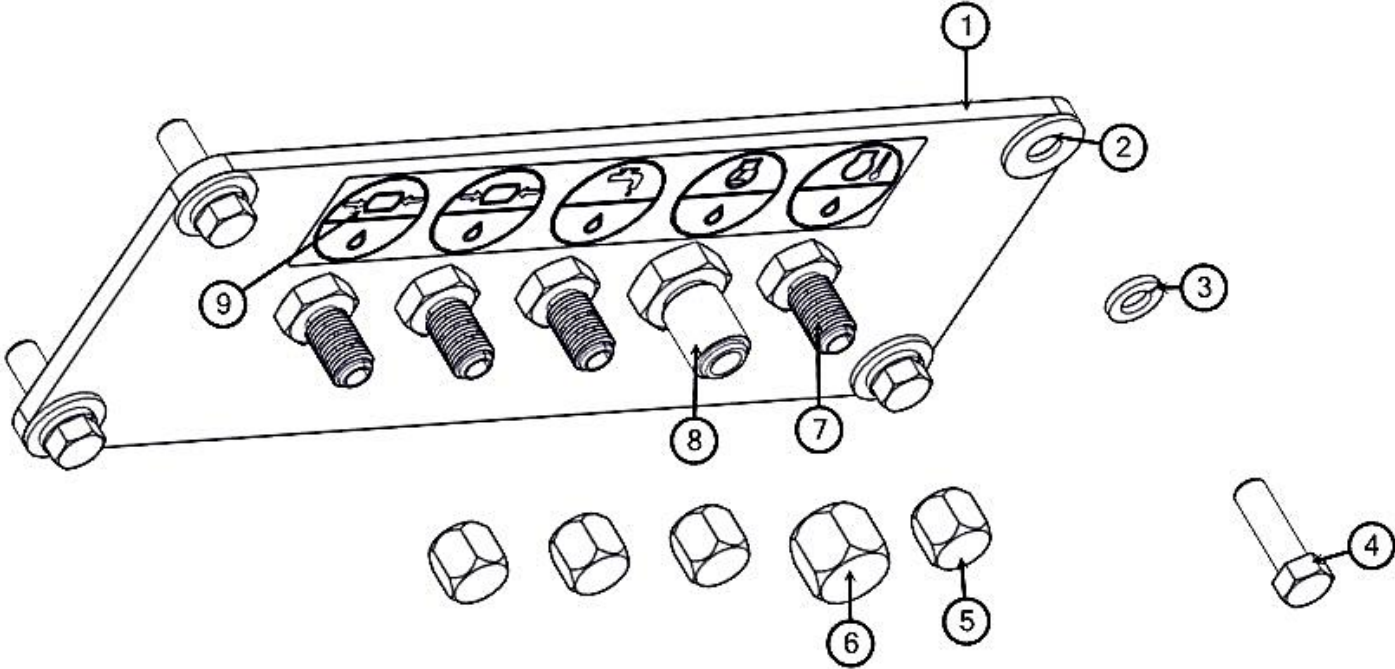

VX200 REMOTE DRAIN
ASSEMBLY

BOM ID	Qty	Name
1	1	8092829 DRAIN PLATE VX200
2	4	U200060 WASHER, FLAT .375 ZP
3	4	U210060 WASHER, LOCK .375 ZP
4	4	U000440 SCREW, HC .375-16 X 1.25 ZP G5
5	4	T405203 CAP, 3/8"FJIC HEX HEAD
6	1	T405205 CAP, 1/2"FJIC HEX HEAD
7	4	T400391 BULKHEAD 6MJ_6MJ
8	1	T400387 BULKHEAD 8MJ_8MJ
9	1	J200032 DECAL, REMOTE DRAIN

VX200 ANTIFREEZE ASSEMBLY

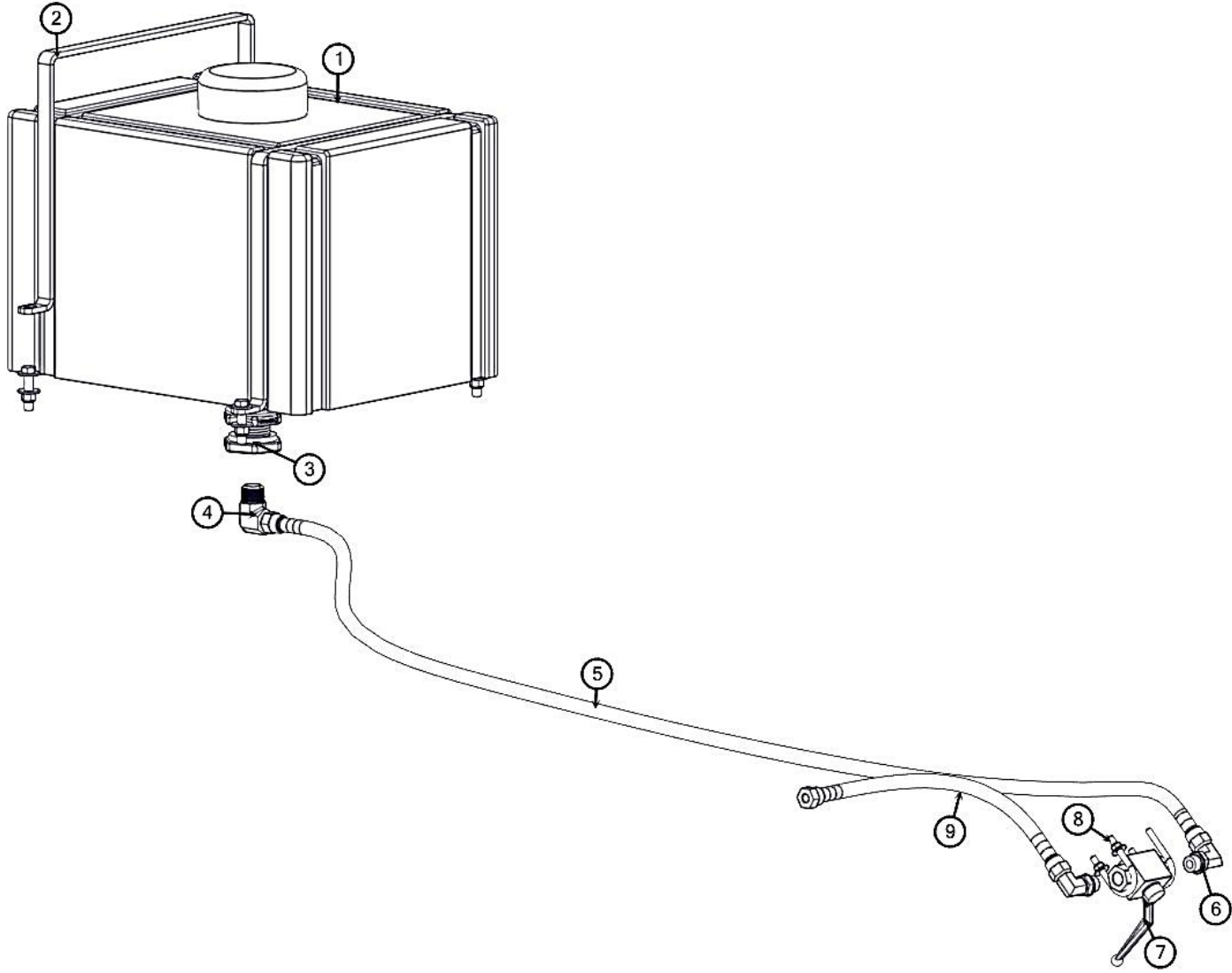

VX200 ANTIFREEZE
ASSEMBLY

BOM ID	Qty	Name
1	1	8048810 TANK, ANTIFREEZE 12GAL W/CAP
2	2	8094267 HOLD DOWN PLATE (ANTIFREEZE)
3	1	8041148 BULKHEAD 3/4"NPT PLASTIC
4	1	T401160 ELBOW, 90 12MP-8MJ
5	1	8046803 HOSE VAC PUSH 8-79"LG
6	2	T401280 ELBOW, 90 8MB(ADJ) - 8MJ
7	1	8031197 VALVE, BALL 1/2" 3000 PSI.MIN
8	2	U010017 U-BOLT .250-20
9	1	8090212 HOSE VAC PUSH 8-24"LG

VX200 ENCLOSURE ASSEMBLY

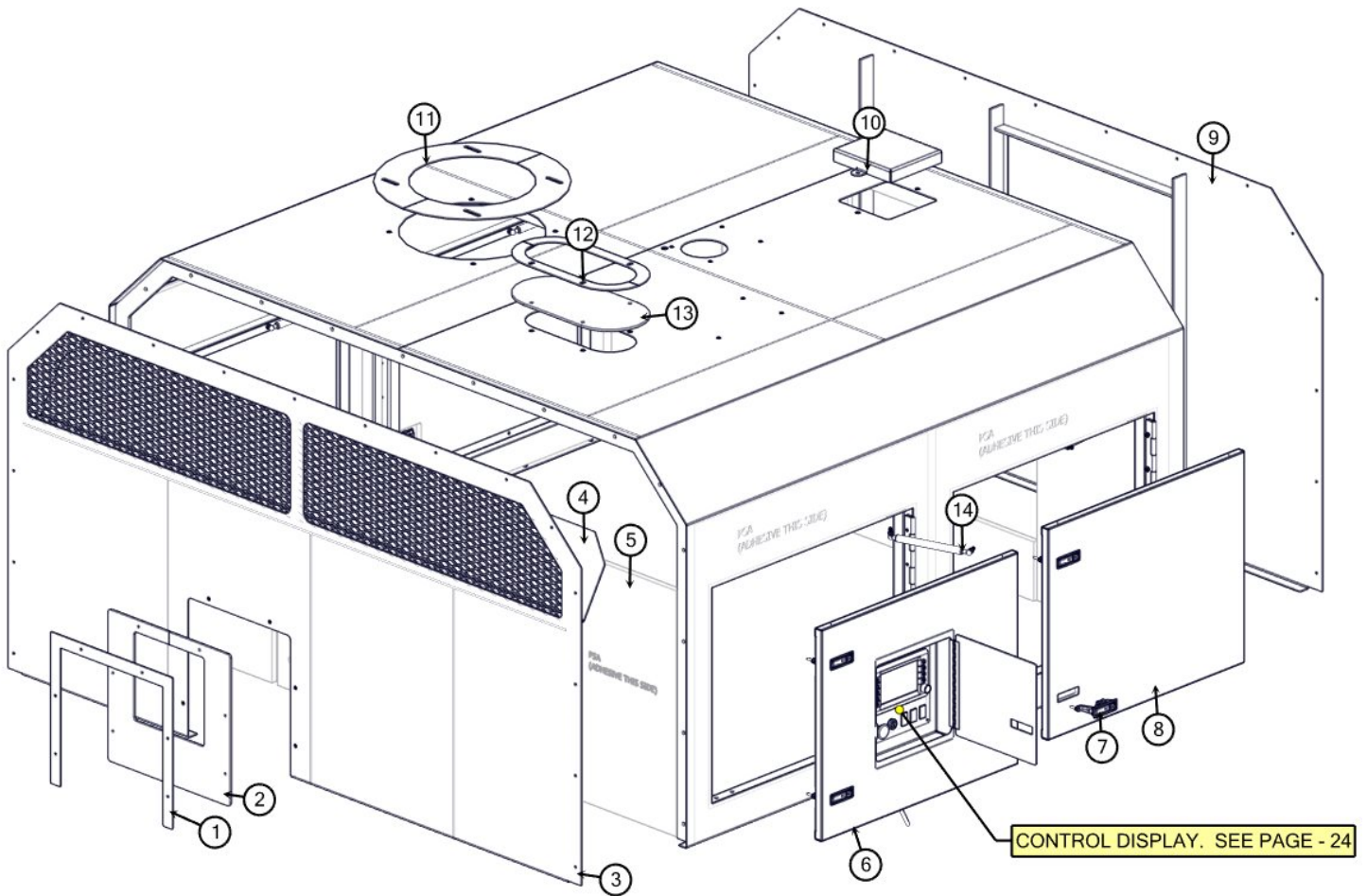

VX200 ENCLOSURE ASSEMBLY

BOM ID	Qty	Name
1	1	8093100 BLOWER AG SEAL PLATE
2	1	8093760 SEAL, BLOWER AG HOSE
3	1	8092445 ENCLOSURE REAR PANEL WELDMENT
4	1	8092198 SOUND DIFFUSER
5	1	8092594 SOUND INSULATION VX200
7	8	8092725 LATCH, KEY LOCKING
8	3	8093086 ENCLOSURE DOOR
9	1	8092446 ENCLOSURE FRONT PANEL WELDMENT
10	1	8092481 ENCLOSURE COVER (RADIATOR ACCESS)
11	2	8092479 ADJUSTABLE FLANGE
12	2	8093293 AIR FILTER PIPE PLATE
13	1	8092801 SEAL, RUBBER
14	4	8093730 SPRING, GAS W/BALL-JOINT FITTINGS

VX200 CONTROL BOX ASSEMBLY

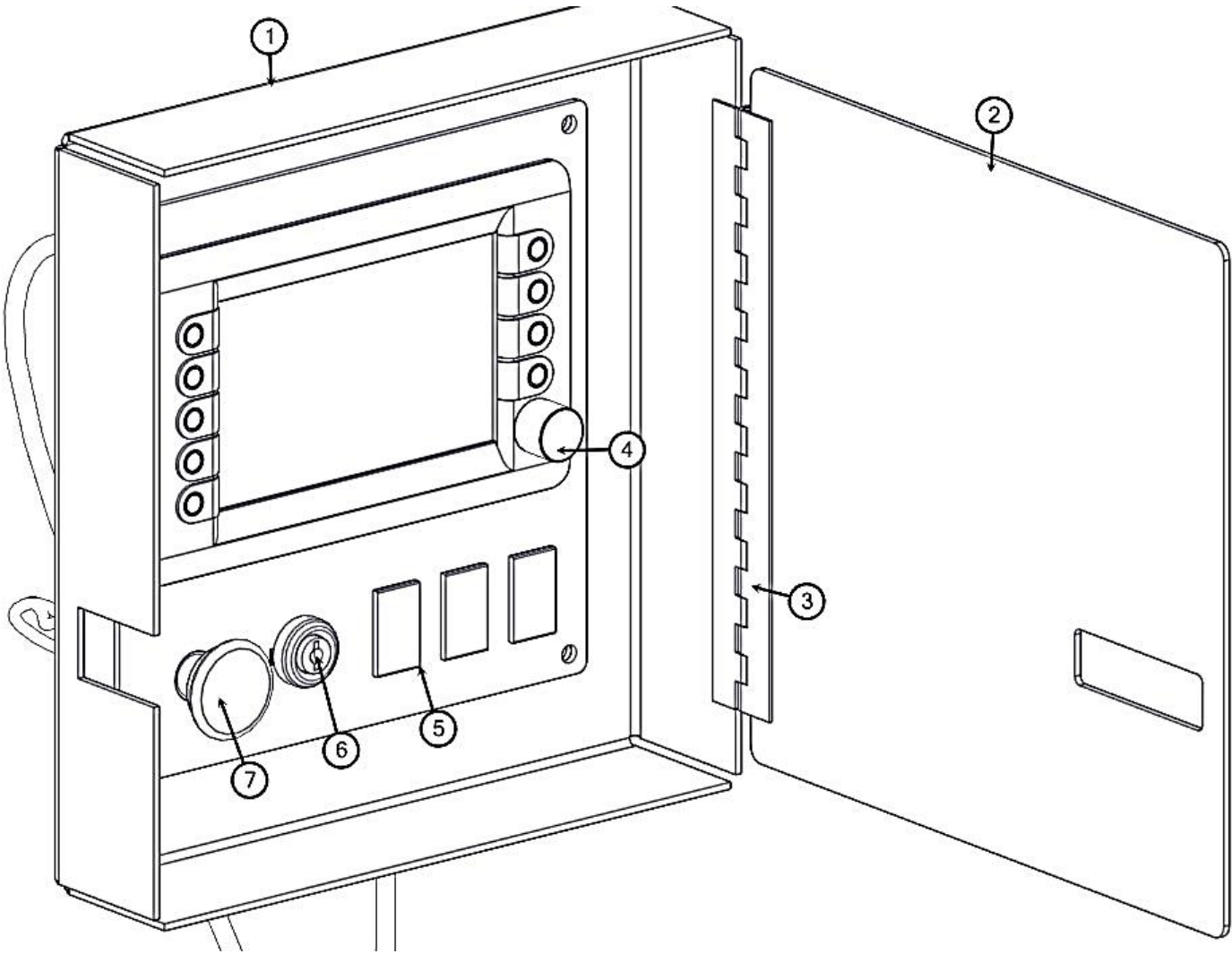

VX200 CONTROL BOX ASSEMBLY

BOM ID	Qty	Name
1	1	8092696 CONTROL BOX
2	1	8092700 DOOR, CONTROL BOX
3	1	8092723 HINGE, CONTROL BOX
4	1	8092954 DISPLAY, 7" IFM COLOR
5	3	X000290 PLUG, ROCKER HOLE
6	1	8030458 SWITCH, IGNITION 3000PP
7	1	X000280 EMERGENCY STOP

VX200 ENGINE ASSEMBLY

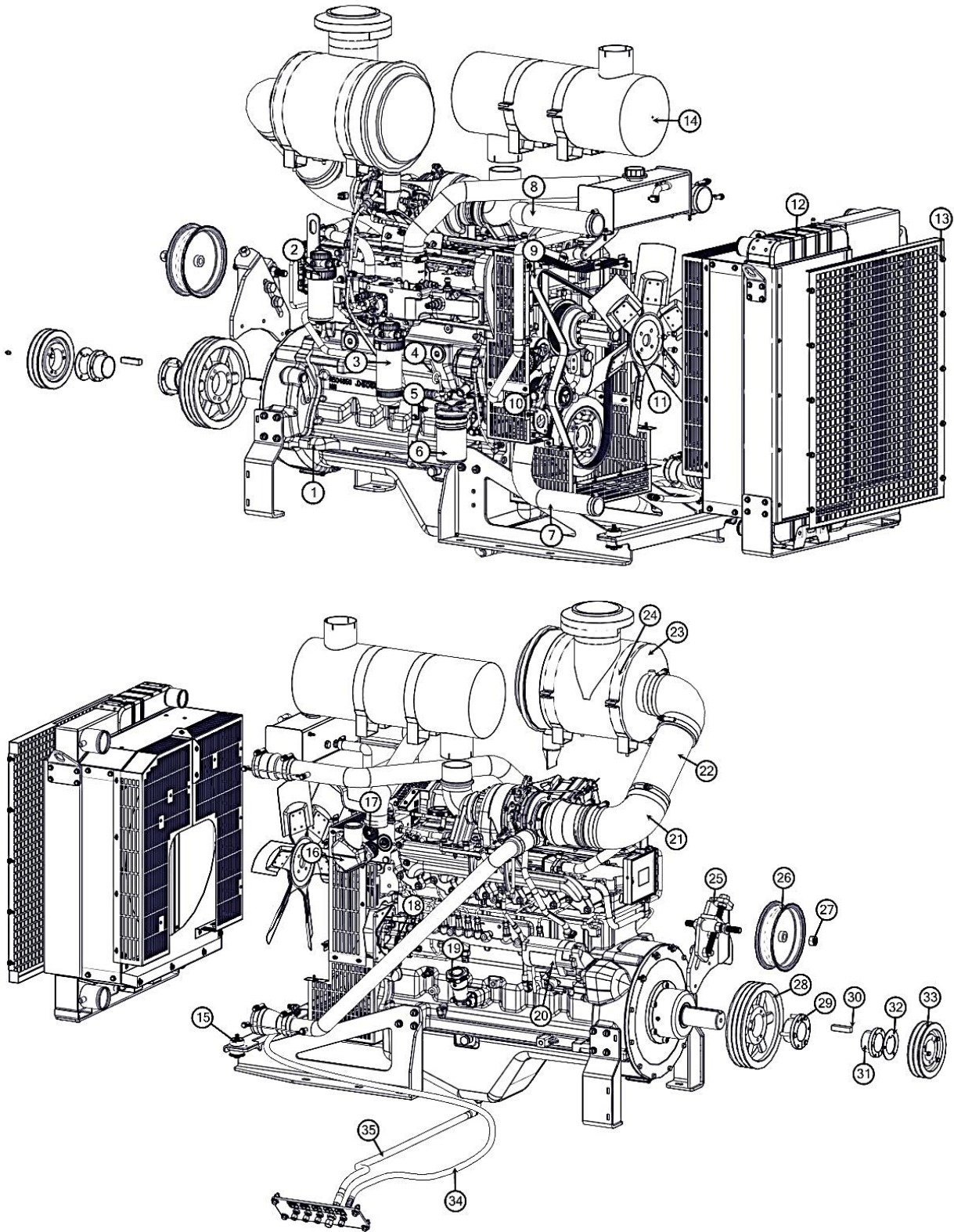

VX200 ENGINE ASSEMBLY

BOM ID	Qty	Name
1	1	8092260 ENGINE, DEERE 200HP PWR UNIT
2	1	8092260-01 FILTER, FUEL WATER SEPARATOR
3	1	8092260-02 FILTER, FUEL
4	1	8092260-03 DIPSTICK, OIL
5	1	8092260-04 HEADER, OIL FILTER
6	1	8092260-05 FILTER, OIL
7	1	8092260-06 HOSE, RADIATOR LOWER
8	1	8092260-11 HOSE, RADIATOR UPPER
9	1	8092260-08 BELT, FAN
10	1	8092260-07 PUMP, WATER
11	1	8092260-09 FAN
12	1	8092260-10 RADIATOR
13	1	8092260-23 GUARD, RADIATOR
14	1	8092260-12 MUFFLER
15	2	8092260-17 MOUNT, RADIATOR
16	1	8092260-13 COVER, THERMOSTAT
17	1	8092260-14 ASSEMBLY, THERMOSTAT
18	1	8092260-15 PUMP, FUEL
19	1	8092260-16 CAP, OIL FILL
20	1	8092260-18 STARTER
21	1	8092260-19 ELBOW, AIR CLEANER ASSEMBLY
22	1	8092260-20 STRAIGHT, AIR CLEANER ASSEMBLY
23	1	8092260-21 AIR FILTER OUTER
24	1	8092260-22 ELEMENT, AIR FILTER
25	1	8094543 WELDMENT, PULLEY TENSIONER STATIONARY
26	1	8093169 PULLEY, 9" TENSIONER MOUNT
27	1	U100200 NUT, HEX .750-10 ZP G5
28	1	8093954 SHEAVE, 3-5VX1130
29	1	8093955 BUSHING, SF 2 1/2"
30	1	8093955-01 KEY, BUSHING 5/8" - 3/16"
31	1	8094122 BUSHING, SK 2 1/2"
32	1	8094136 RETAINER, 2.5" SHAFT
33	1	8093956 SHEAVE, 2BX0700
34	1	8041452 HOSE ASSY VAC 6-70" ST-90
35	1	8041490 HOSE ASSY VAC 6-52" ST-90

* NOT SHOWN:
ASSEMBLY, ENGINE BAY HARNESS VX200 - X200202

VX200 BLOWER ASSEMBLY

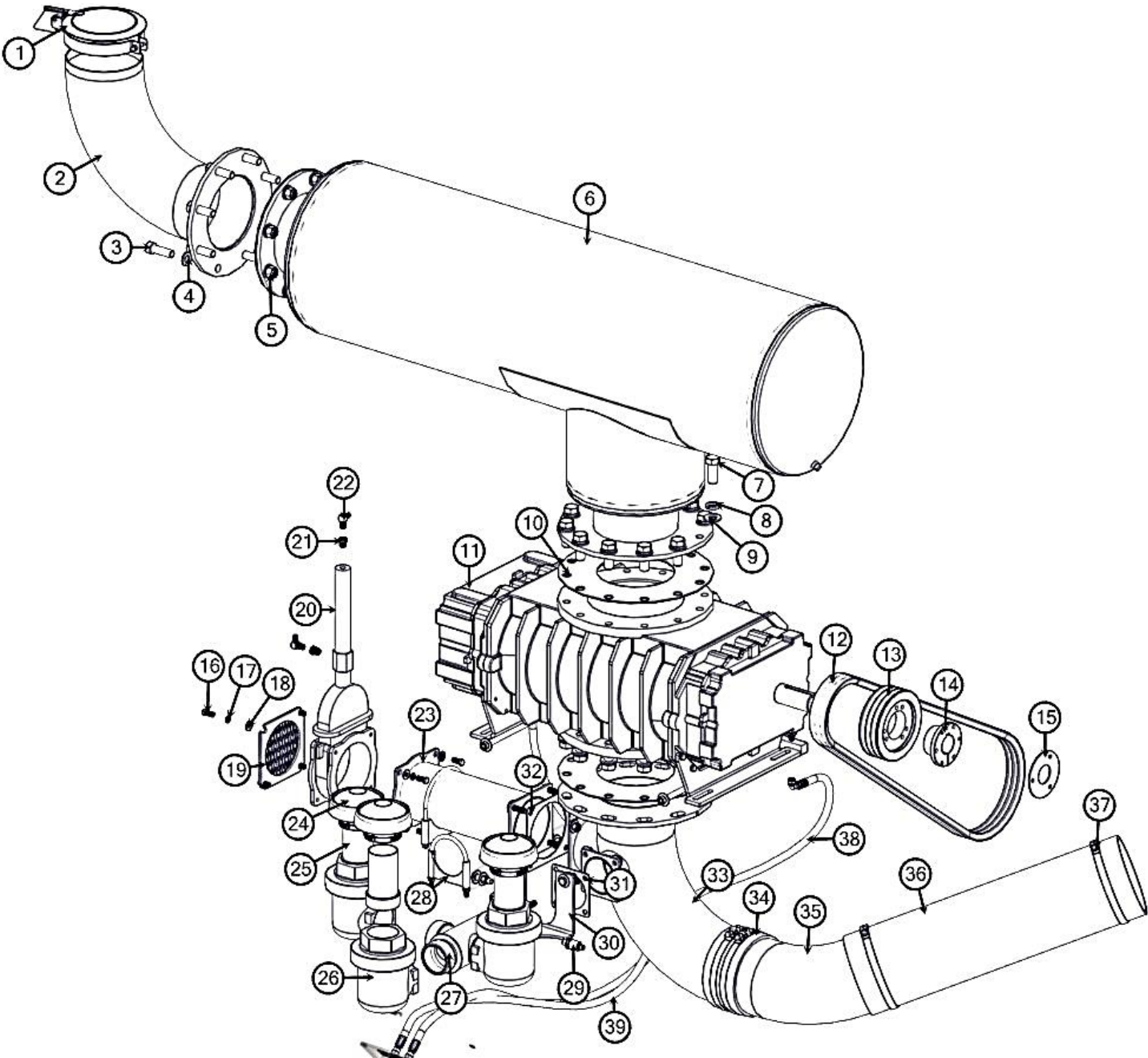

VX200 BLOWER ASSEMBLY

BOM ID	Qty	Name
1	1	8094195 RAIN CAP, 8" SILENT
2	1	8092519 SILENCER OUTLET WELDMENT
3	8	U001420 SCREW, HC .750-10 X 2.50 ZP G5
4	16	U200160 WASHER, FLAT .750 ZP
5	8	U120040 NUT, LOCK NY .750-10 ZP G2
6	1	8092091 SILENCER, AIR 10" IN - 8" OUT
7	24	U001551 SCREW, HC .875-9 X 2.25 ZP G5
8	24	U210180 WASHER, LOCK .875 ZP
9	24	U200168 WASHER, FLAT .875 ZP SAE HARD
10	2	8092811 GASKET, BLOWER FLANGE
11	1	8092099 BLOWER, RAM 624 3200CFM
12	1	8093952 BELT, 3-5VP870 BANDED
13	1	8093950 SHEAVE, 3-5VX0750 SF
14	1	8093951 BUSHING, SF 2
15	1	8092817 RETAINER, 2" BUSHING (3 HOLE)
16	8	U000420 SCREW, HC .375-16 X 1.00 ZP G5
17	8	U210060 WASHER, LOCK .375 ZP
18	8	U200060 WASHER, FLAT .375 ZP
19	1	8049371 BOTTOM PLATE WELDMENT 6" VALVE
20	1	8043577 VALVE, GATE 6" W/HYD. CYLINDER DBL ACT
21	2	T400023 REDUCER 6MP_4FP
22	2	T401100 ELBOW 90 4MP_4MJ
23	1	8091659 WELDMENT, 6" PIPE EXTENSION
24	3	8091506-01 CAP, AIR IN-TAKE 3"ID
25	3	8045238 UNION EXHAUST 3" OD-MNPT
26	3	8092079 VALVE, 3" AIR RELIEF SET 18"HG
27	1	8092573 VAC RELIEF WELDMENT
28	1	8031193 CLAMP, U-BOLT 4" EXHAUST
29	1	X000085 PRESSURE TRANSDUCER
30	1	8092307 PIPE MOUNT 4"
31	1	8092812 GASKET, 4" PIPE
32	1	8092813 GASKET, 6" PIPE
33	1	8092319 INTAKE WELDMENT
34	1	8092966-004.00 TUBE, TEX-AQUA-HD 8" X 4"LG
35	1	8094401 ELBOW, 45 8"OD X 4"LEG
36	1	8092966-030.00 TUBE, TEX-AQUA-HD 8" X 30"LG
37	4	8092896 CLAMP, T-BOLT 8" HOSE
38	1	8049140 HOSE ASSY VAC 6-85" ST-90
39	1	8047171 HOSE ASSY VAC 6-96" ST-ST

VX200 WATER PUMP TSF2421 ASSEMBLY

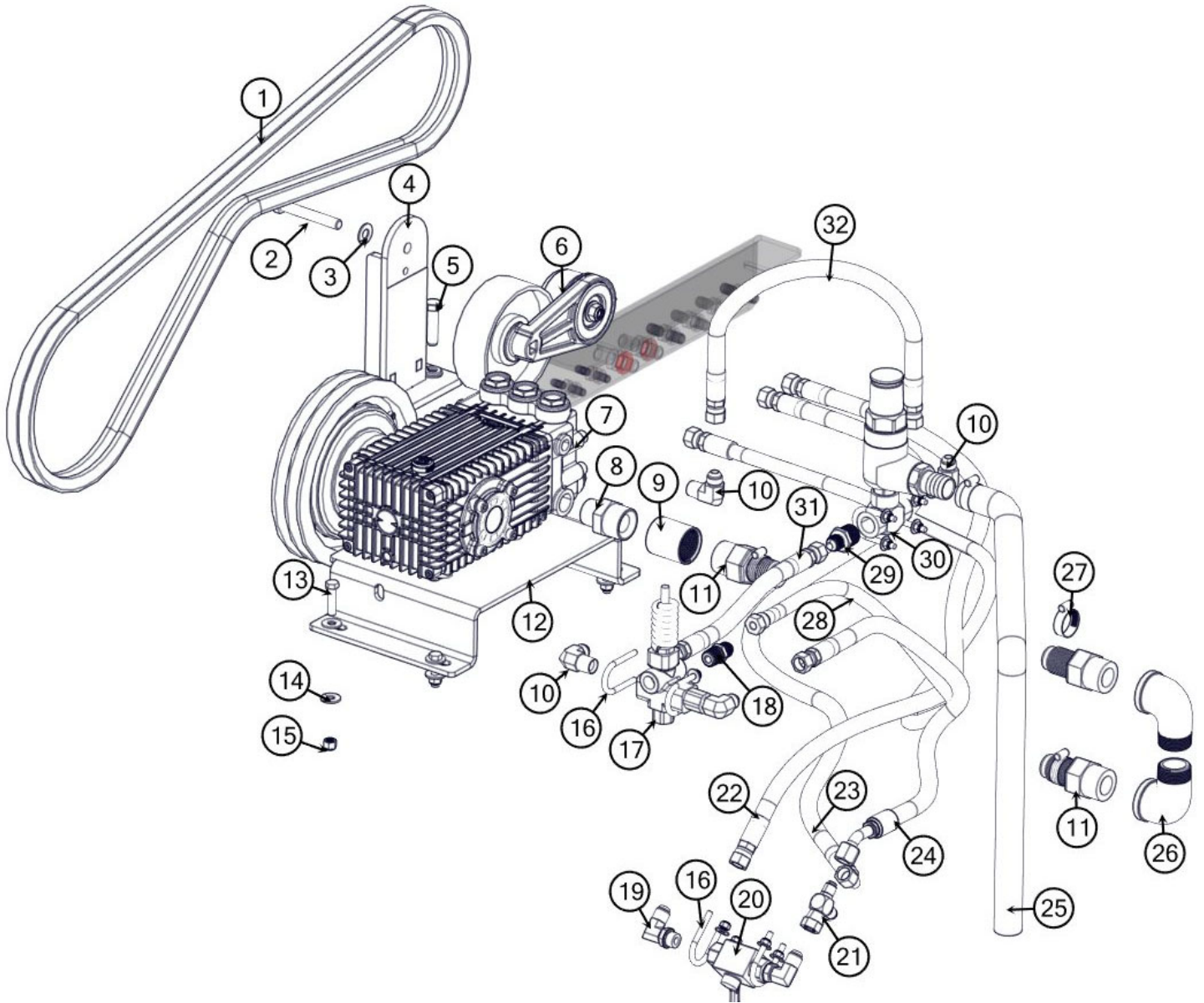

VX200 WATER PUMP TSF2421 ASSEMBLY

BOM ID	Qty	Name
1	2	8097334 BELT, BP85 PREDATOR GATES ONLY
2	1	U001655 SCREW, HC 12MM X 1.75 X 90MM G8.8
3	4	U200110 WASHER FLAT .500 ZP SAE HARD
4	1	8097112 WELDMENT, AUTO TENSIONER, ECO200
5	2	U000880 SCREW, HC 1/2-13 X 2.00 ZP G5
6	1	8096205 AUTO TENSIONER FLAT FACED PULLEY
7	1	8093712 PUMP, WATER TSF2421 W/CLUTCH
8	1	T400618 REDUCER, 1"MP-1-1/4"MP
9	1	T422080 COUPLING PIPE 1 1/4" STEEL
10	4	T401140 FITTING, ELBOW 90°, 8MP-8MJ 90°
11	3	8041312 FITTING, 1-1/4"MP-1-1/4"HB
12	1	8093520 PUMP BRACKET TSF2421
13	4	U000460 SCREW, HC .375-16 X 1.50 ZP G5
14	12	U200060 WASHER, 3/8" USS FLAT ZP
15	4	U110060 NUT, ST .375-16 ZP G2
16	6	U010017 U-BOLT, .250-20 X .75
17	1	8030341 VALVE, UNLOADER, GREEN SPRING
18	1	T400040 UNION, 8MP - 8MJ
19	2	T401280 ELBOW, 90 8MB-8MJ
20	1	8031197 VALVE, BALL 1/2" 3000 PSI
21	1	T402155 TEE 8FJ_8MJ_8MJ
22	1	8041489 HOSE ASSY VAC 8-60" ST-ST
23	1	8043055 HOSE ASSY VAC 8-60" ST-45
24	1	8094059 HOSE ASSY VAC 8-23.5" ST-90
25	1	8042941 HOSE VAC CLEAR VINYL 1-1/4-27
26	2	8041311 ELBOW, 90 1.25 STREET EL GALVAN
27	3	8040677 CLAMP, HOSE 1 1/4 - 2 1/8 HD
28	1	8041489 HOSE ASSY VAC 8-60" ST-ST
29	1	T400080 REDUCER, 3/4"MP-1/2"MJ (12MP-8MJ)
30	1	T402160 TEE 12FP_12FP_12FP
31	1	8042934 HOSE ASSY VAC 4-12" ST-ST
32	1	8044749 HOSE ASSY VAC 4-23.5" ST-90

VX200 HYDRAULIC PUMP ASSEMBLY

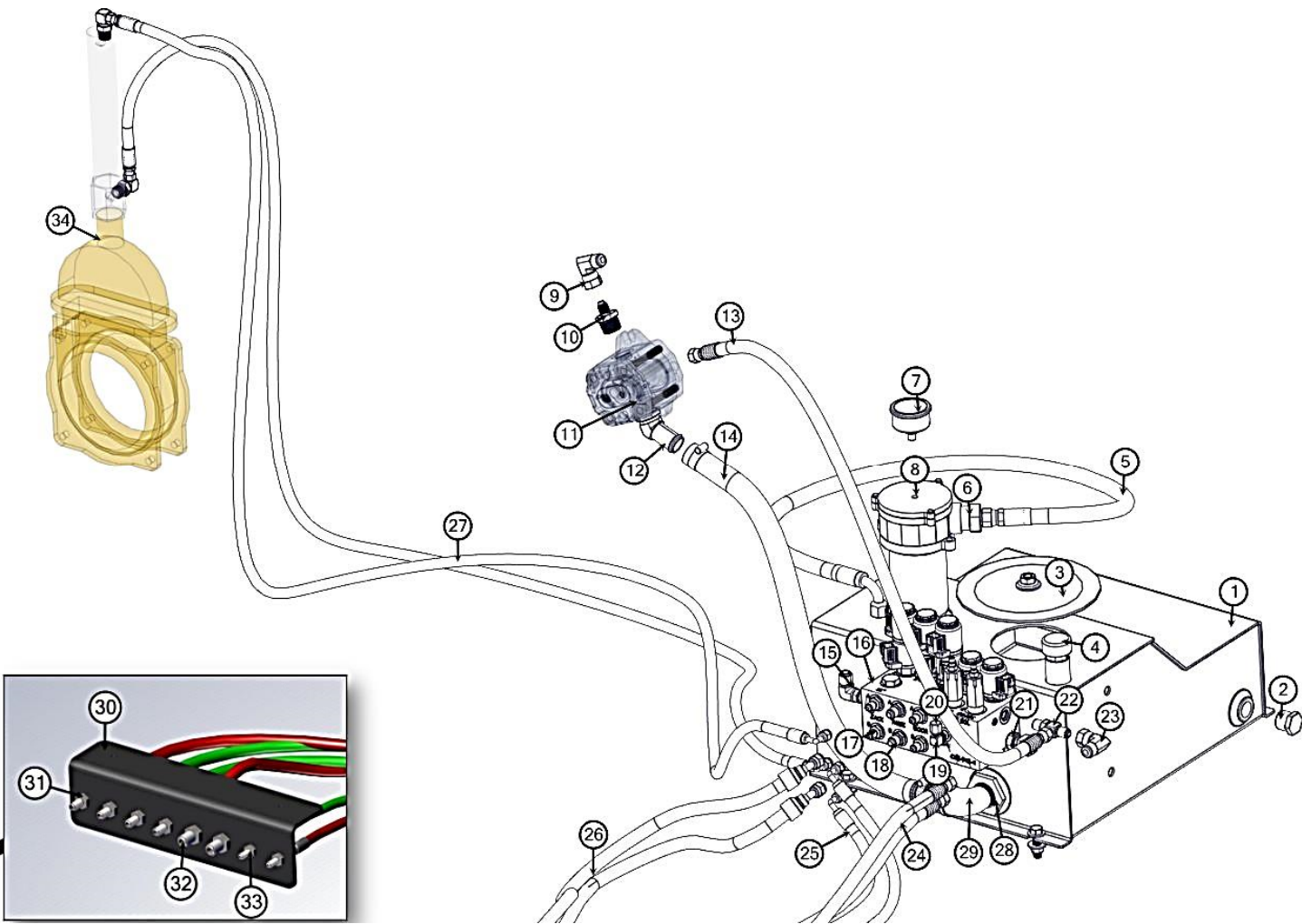

VX200 HYDRAULIC PUMP ASSEMBLY

BOM ID	Qty	Name
1	1	8093054 WELDMENT, TANK HYD 9 GAL.
2	1	T405065 PLUG, 3/4"MP
3	1	4800758 CLEANOUT COVER
4	1	8047330-14 CAP, PLASTIC GRAY
5	1	8047766 HOSE ASSY VAC 8-20" ST-90
6	1	T400240 REDUCER, 16MB-8MJ
7	1	8047456-1 GAUGE, FILTER DIAL
8	1	8047456 FILTER, HYD OIL AUX HYD
9	1	T401228 ELBOW 90 6MJ-6FJ
10	1	T400085 REDUCER 12MP_6MJ
11	1	8092259 PUMP, GEAR 8.4CC CCW DEERE
12	1	8043964 ELBOW, 45 1"HB-3/4"MB
13	1	8042179 HOSE ASSY VAC 6-36" ST-ST
14	1	T300180-30.00 HOSE, WIRE BRAIDED #16-30"LG
15	1	T401260 ELBOW, 90 6MB-8MJ
16	1	8048690-02 MANIFOLD ASSY BOOM LWR (CROSS 3)
17	4	T400550 REDUCER, 6MB-4MJ
18	2	T400037 UNION, 6MB-6MJ
19	1	T401230 ELBOW, 90 4MB-4MJ
20	1	T405200 CAP, 1/4" FJIC HEX HEAD
21	1	T401250 ELBOW, 90 6MB-6MJ
22	1	T402148 TEE, 6MB-6MJ-6MJ
23	1	T401228 ELBOW 90 6MJ-6FJ
28	1	8011058 STRAINER SUCTION 1 1/2"OD X 1"ID
29	1	T420080 ELBOW, STREET 1"MP - 1"FP 90 DEG
30	1	8094275 HOSE CONNECTION PLATE
31	4	T400391 BULKHEAD 6MJ_6MJ
32	2	T400387 BULKHEAD 8MJ_8MJ
33	2	T400385 BULKHEAD 4MJ_4MJ
34	1	8043577 VALVE, GATE 6" W/HYD. CYLINDER DBL ACT

VX200 SPOIL TANK & DOOR ASSEMBLY

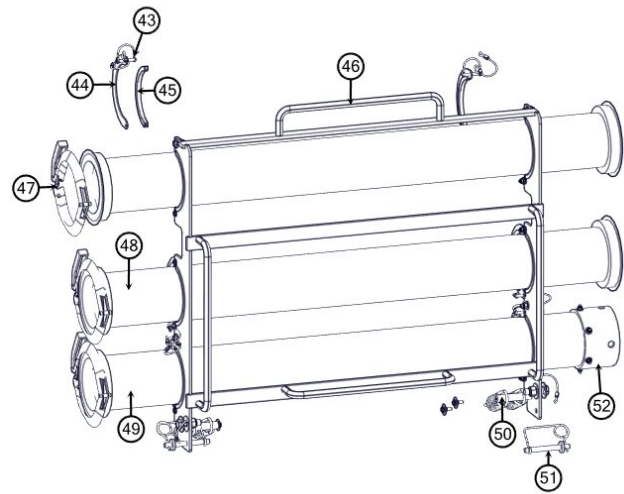
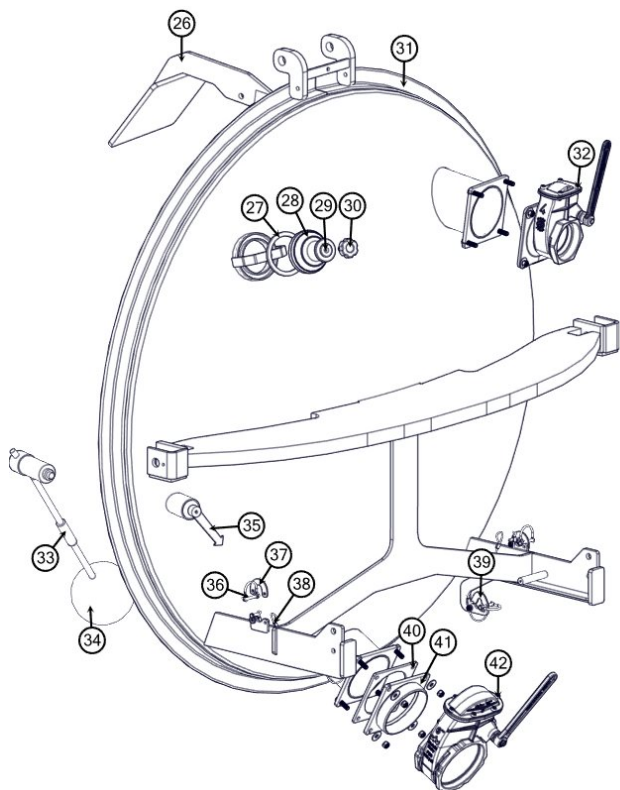
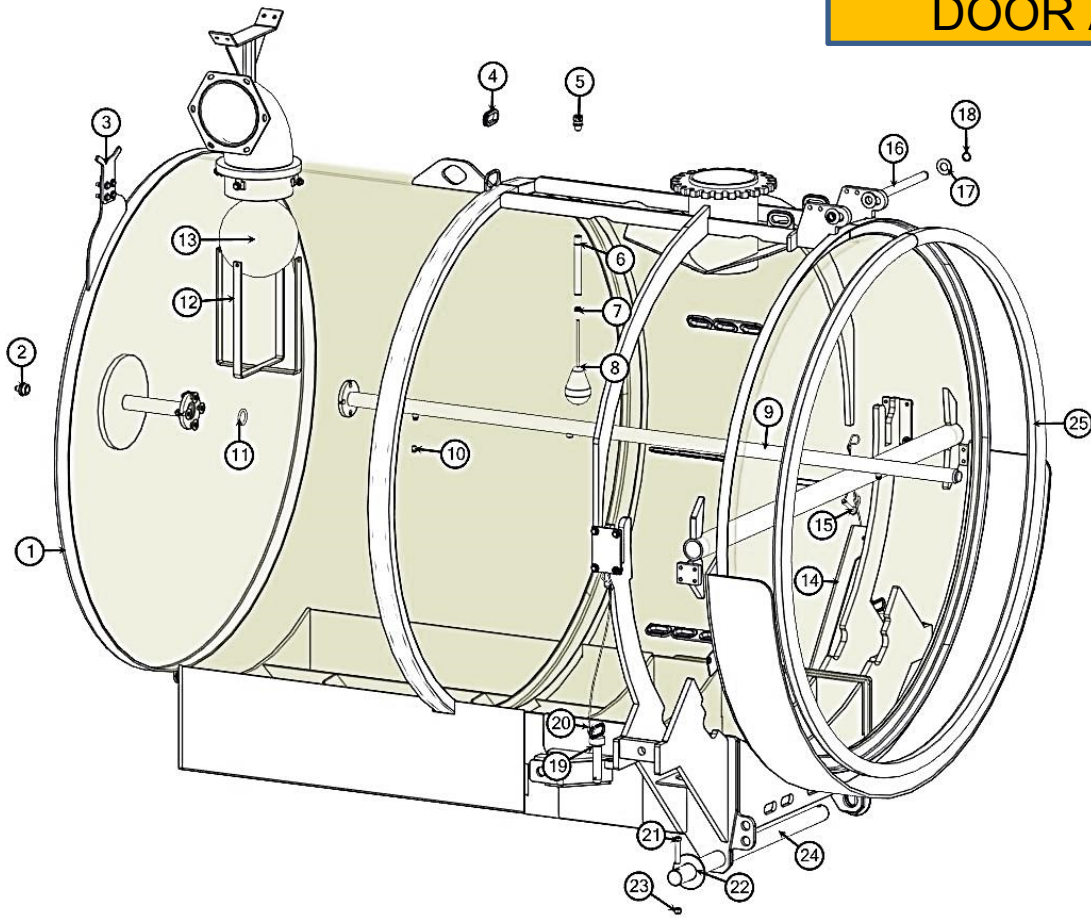

VX200 SPOIL TANK & DOOR ASSEMBLY

BOM ID	Qty	Name
1	1	8093775 WELDMENT, TANK 1600 66"OD BOOM
2	1	T400310 REDUCER, 1"MB - 3/8"MJ
3	1	8092900 FILTRATION SUPPORT CRADLE PLATE
4	14	8042812 GROMMET, 2"ID X 3"OD X 1/4"WOG
5	1	X000113 STRAIN RELIEF 1/2"NPT
6	1	8040769 TANK FULL SWITCH 8"
7	1	8041291 BUSHING, RUBBER 7/8" HEAD 21/32" BODY
8	1	8030531 SWITCH, FLUID LEVEL (SPOIL TANK)
9	1	8094636 WELDMENT, TANK CLEANOUT
10	5	8030369 NOZZLE, TANK CLEANOUT
11	1	8030446 O'RING #328 BUNA-N
12	1	8092438 CAGE, FLOAT BALL 10"
13	1	8043686 FLOAT BALL 10" STAINLESS
14	1	8044915 TANK SAFETY BRACE
15	1	8044978 PIN, SAFETY T2000 3/8" X 4.00"LG
16	1	8040058 DOOR HINGE ROD
17	6	U200170 WASHER, FLAT 1.00 ZP
18	2	U500020 SNAP RING EXT 1" SHAFT ZP
19	2	8041626 HITCH PIN 1" X 4 1/2"
20	2	8093841 ASSEMBLY, LANYARD CABLE 30"
21	2	U000930 SCREW, HC .500-13 X 3.00 ZP G5
22	2	U200180 WASHER, FLAT 2.125"ID X 4.50"OD
23	2	U160018 NUT, LOCK .500-13 NY ZP
24	1	8092765 ROD, TANK PIVOT
25	1	8093728 SEAL, DOOR 66"OD TANK
26	1	8094565 DEFLECTOR WELDMENT
27	1	8032007 GASKET, 4" FLAT ALUM COUPLER
28	1	8031048 SIGHTGLASS, 5" (GLASS ONLY)
29	1	8031047 PLATE, SIGHTGLASS
30	1	8031046 SCREW, HANDWHEEL SIGHTGLASS
31	1	8093596 DOOR, HYD STAGE 3" BOOM 66"OD
32	1	8046215 VALVE, 4" GATE BRASS LEVER FLANGE
33	1	8092325 GAUGE, SPOIL FLOAT
34	1	8093679-04 BALL, SPOIL FLOAT 7"
35	1	8093679-05 ARROW, LEVEL INDICATOR
36	4	8093706 PIN LINCH 1/4" X 1 3/4" W/WIRE LOCK
37	2	8093260 PLATE, LANCE RETAINER
38	4	8093703 CABLE, LANYARD 11"LG
39	2	8093767 PLATE, WASH WAND RETAINER
40	1	8046191 GASKET, DOOR LE INLET/OUTLET
41	1	8046199 GATE VALVE TANK FLANGE 6"
42	1	8030849 VALVE, 6" GATE BRASS LEVER FLANGE
43	6	8093706 PIN, LINCH 1/4" X 1 3/4"
44	6	8092230 TUBE RETAINER, 6"
45	12	8049336-009.50 EDGE TRIM, 1/4" X 1/2"LEG X 22"
46	1	8093688 WELDMENT, TOOL RACK BOOM 6"
47	3	8092944 CLAMP, QUICK 6"
48	2	8092942 TUBE, 6" ALUMINUM 60"LG
49	1	8093709 TOOL SUCTION 6" ASSEMBLY
50	4	8093365 SPRING, 1.75 X 6"
51	2	8093705 PIN, LINCH 1/2" X 3 1/2" W/WIRE LOCK SQ
52	1	8093711 TUBE, SUCTION TOOL END 4"

VX200 HYDRAULIC ARM ASSEMBLY

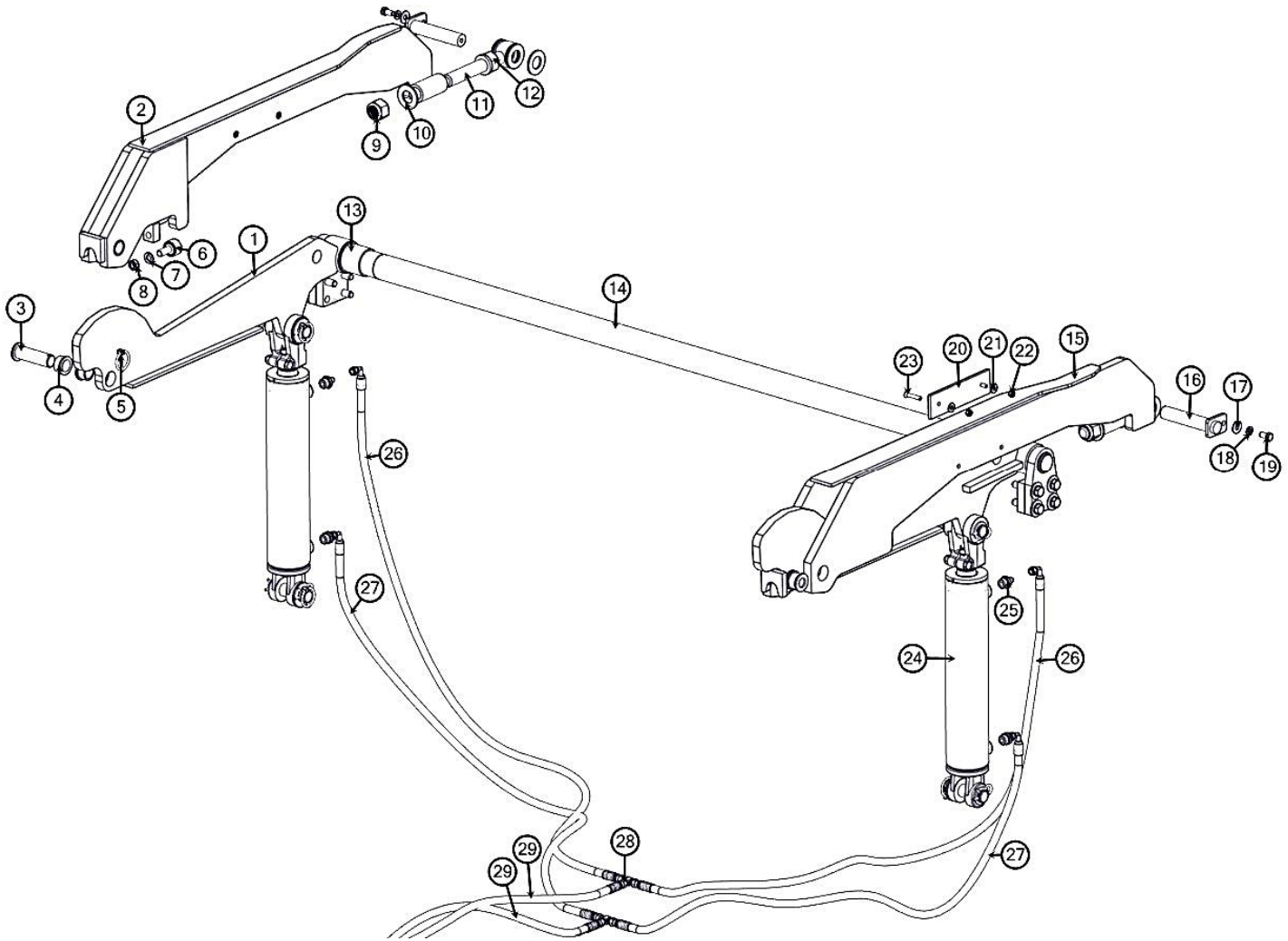

VX200 HYDRAULIC ARM ASSEMBLY

BOM ID	Qty	Name
1	1	8047958 LINKAGE ARM SHORT (RIGHT) WELDMENT
2	1	8044867 LINKAGE ARM LONG (CURB) WELDMENT
3	6	8042489 CYLINDER PIN
4	8	8041883 BUSHING BRONZE 1.25 X 1.00 X .63 FL
5	6	U340050 PIN LINCH 3/16 X 1 9/16 ZP
6	2	W000020 BEARING, CAMROL 1.25"
7	2	U210100 WASHER, LOCK .500 ZP
8	2	U160015 NUT, JAM .500-20
9	2	U120060 NUT, LOCK 1.00-8 NY ZP G2
10	12	U200170 WASHER, FLAT 1.00
11	2	8043131 ROD END 1"-8 X 7 1/2"LG
12	2	U100240 NUT, HEX 1.00-8 ZP G2
13	2	8041602 BUSHING BRONZE 2.25 X 2.00 X 2.00 FL
14	1	8093597 LINKAGE CROSS TUBE WELDMENT
15	1	8044868 LINKAGE ARM LONG (STREET) WELDMENT
16	2	8043844 CYLINDER PIN FLANGED 1" X 5 1/2"LG
17	2	U200060 WASHER, FLAT .375 ZP
18	2	U210060 WASHER, LOCK .375 ZP
19	2	U000400 SCREW, HC .375-16 X .75 ZP G5
20	2	8047449 PLASTIC STRIP HYD DOOR GUIDE
21	4	U200020 WASHER, FLAT .250 ZP
22	4	U120000 NUT, LOCK NY .250-20 ZP G2
23	4	U030018 SCREW, SFH .250-20 X 1.50 ZP
24	2	8092326 CYLINDER, HYD 3" X 12"
25	4	T400611 REDUCER, 8MB-4MJ
26	2	8044763 HOSE ASSY VAC 4-60" ST-90
27	2	8093184 HOSE ASSY VAC 4-55" ST-90
28	2	T402035 TEE 4MJ_4MJ_4MJ
29	2	8042354 HOSE ASSY VAC 4-160" ST-ST

*NOT SHOWN
2 - 8090251 FITTING, ORFICE 0.020 4MB-4MJ

VX200 FILTRATION ASSEMBLY

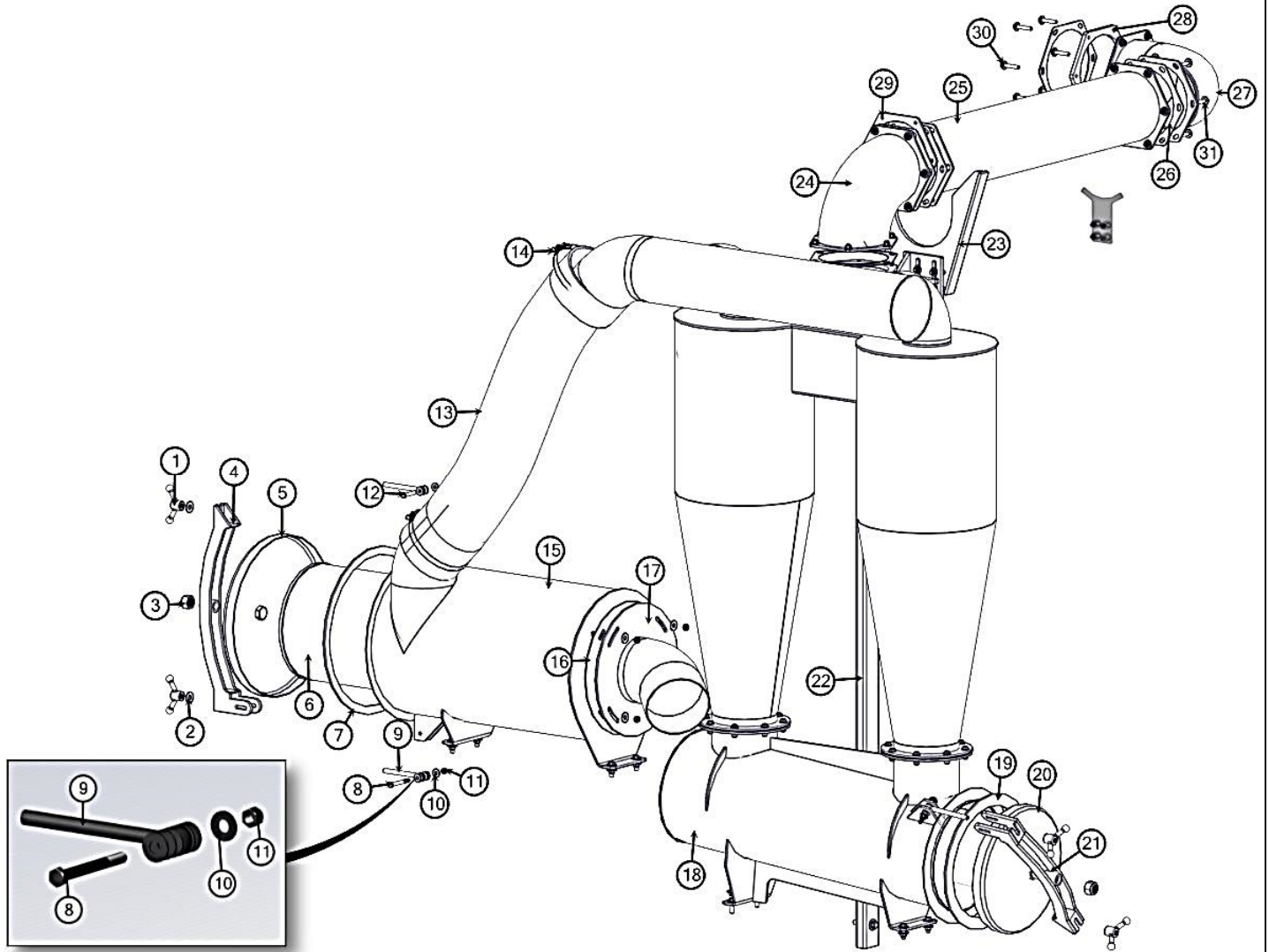

VX200 FILTRATION ASSEMBLY

BOM ID	Qty	Name
1	4	8041594 HANDLE, WING REV FLOW CYC/FILTER
2	2	U200100 WASHER, FLAT .500 ZP
3	2	U120060 NUT, LOCK 1.00-8 NY ZP G2
4	1	8092007 LATCH, AIR FILTER 3000 CFM SINGLE
5	1	8092009 DOME, AIR FILTER 3000 CFM SINGLE
6	1	8092258 FILTER, AIR 14.5 X 32
7	1	8092008 GASKET, AIR FILTER HD VX200
8	2	U000580 SCREW, HC .375-16 X 3.50 ZP G5
9	4	8041593 BOLT, EYE 1/2-13 X 6"
10	20	U200060 WASHER, FLAT .375 ZP
11	4	U120110 NUT, LOCK .375-16 NY ZP
12	2	U000520 SCREW, HC .375-16 X 2.25 ZP G5
13	1	8093023 HOSE VAC AG SUCTION 8" X 54 1/2"LG
14	2	8092896 CLAMP, T-BOLT 8" HOSE
15	1	8092282 AIR FILTER 3000 CFM SINGLE
16	1	8092815 GASKET, AIR FILTER OUTLET
17	1	8092661 WELDMENT, AIR FILTER OUTLET
18	1	8091639 CYCLONE ASSEMBLY 3000 CFM
19	1	8041612 GASKET, REV FLOW CYCLONE
20	1	8041402 DOME, CYCLONE REV FLOW
21	1	8041552 LATCH, CYCLONE DOME REV FLOW
22	1	8092843 BRACE, REC TUBE (CYCLONE)
23	1	8093047 WELDMENT, FILTRATION SUPPORT
24	1	8092431 FILTRATION ELBOW WELDMENT 2
25	1	8092888 WELDMENT, PIPE FILTRATION LONG
26	6	8092436 GASKET, FILTRATION CONNECTION
27	1	8092430 FILTRATION ELBOW WELDMENT 1
28	2	8092892 FILTRATION SPACER PLATE
29	1	8092916 FILTRATION CONNECTION PLATE
30	12	U000520 SCREW, HC .375-16 X 2.25 ZP G5
31	12	U000460 SCREW, HC .375-16 X 1.50 ZP G5

VX200 WATER TANK ASSEMBLY

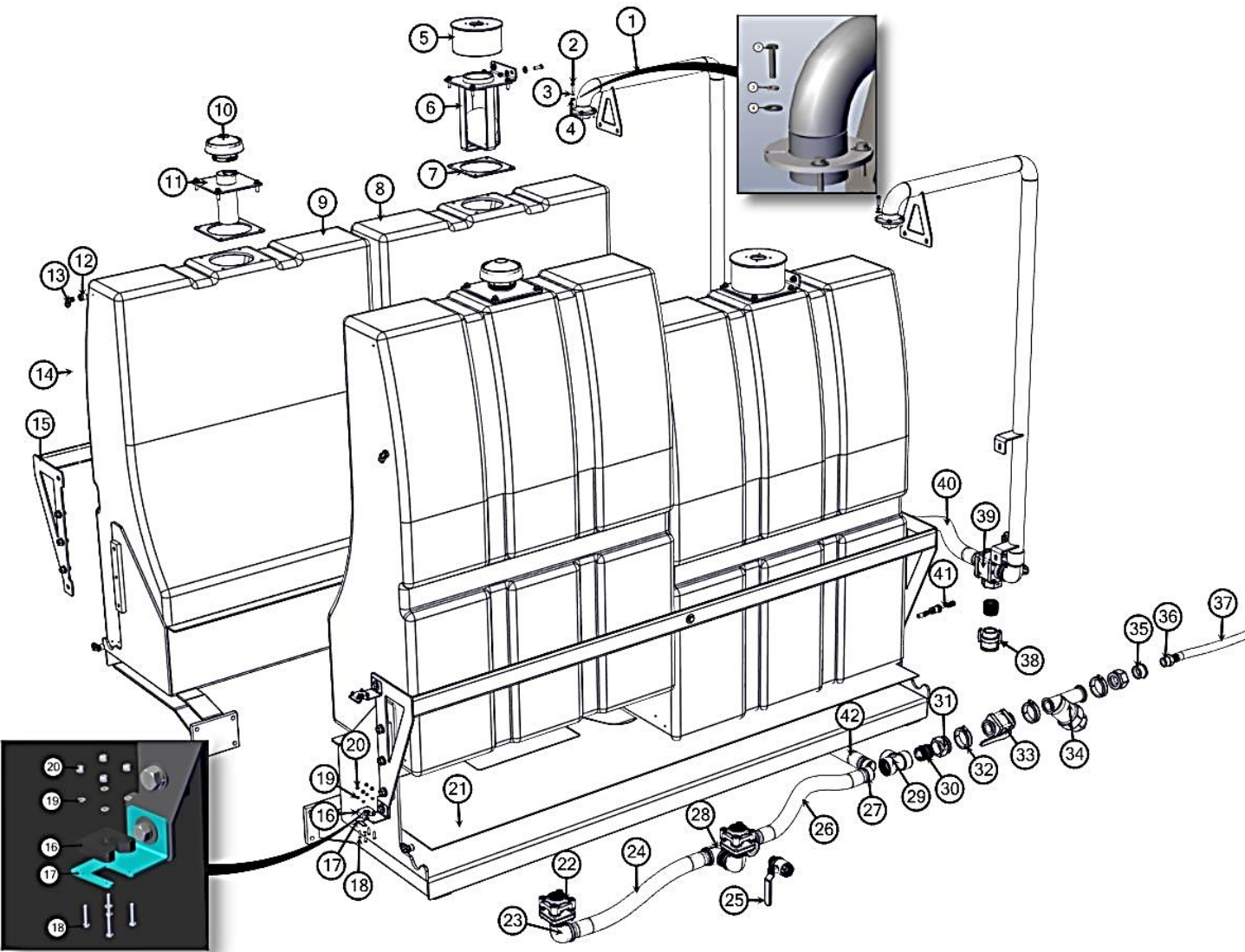

VX200 WATER TANK ASSEMBLY

BOM ID	Qty	Name
1	2	8094480 QUICKFILL 200 GALLON WELDMENT
2	8	U000080 SCREW, HC .250-20 X 1.25 ZP G5
3	8	U210020 WASHER, LOCK .250 ZP
4	8	U200020 WASHER, FLAT .250 ZP
5	2	8094105 QUICKFILL ATTACHMENT WELDMENT
6	2	8094485 FLOAT BALL ASSEMBLY
7	4	8094558 GASKET, SADDLE TANK CHECK VALVE
8	1	8094439 TANK, WATER RIBBED POLY 400 GALLON
9	1	8094439 TANK, WATER RIBBED POLY 400 GALLON
10	2	8091506-01 CAP, AIR IN-TAKE
11	2	8094462 WELDMENT, WATER TANK VENT
12	4	T400024 ADAPTER STR -8MP -6FP STEEL GALV
13	4	T320310 6HOSE_6MP
14	2	8093015-056.00 TUBE, VINYL 3/8"ID X 1/2"OD X 56"
15	2	8094466 BRACE, WATER TANK WELDMENT
16	2	8094246 GRIPPER, WAND/LANCE
17	2	8094606 TOOL HOLDER PLATE
18	8	U030794 SCREW, PAN HD PHIL #8-32 X 1.00
19	16	U030801 WASHER, FLAT #8
20	8	U030800 NUT, LOCK NY #8-32
21	2	8094135 STRIP, ISOLATOR SADDLE TANK
22	4	8049750 BULKHEAD, 2" BOT. DRAIN BANJO
23	6	T420125 ELBOW, STREET 2"MP-2"FP 90 DEG
24	2	8043398-030.00 HOSE VAC CLEAR VINYL 2-30"
25	2	8045813 VALVE, BALL 1 1/4" M X F BRASS
26	1	8043398-027.00 HOSE VAC CLEAR VINYL 2-27"
27	8	T410115 FITTING, 2"MNPT X 2"BARB STEEL
28	4	8094550 TEE, 2"NPT BLACK IRON
29	1	8090204 FITTING, TEE 2" BANJO
30	6	8030409 NIPPLE, CLOSE 2" SCHD 40 IRON
31	2	8030996 MANIFOLD, 2" BANJO FEMALE ADAPT
32	3	8031000 CLAMP, 2" BANJO WORM
33	1	8030998 VALVE, 2" BALL-MANIFOLD
34	1	8031001 STRAINER, Y 2" FLANGE 80 MESH
35	1	8043843 REDUCER, 2"MP X 1 1/4"FP GALV
36	1	8041312 FITTING, 1 1/4"MP - 1 1/4"HB
37	1	8043076 HOSE VAC CLEAR VINYL 1 1/4-37"
38	1	8031219 COUPLING, 2" ALUM MP X FCAMLOCK
39	1	8094548 VALVE, 3-WAY 2"NPT BANJO
40	1	8046676-069.00 HOSE AG SUCTION 2-69"LG
41	2	8090896 SWITCH, WATER LEVEL (HORIZ)
42	1	8043398-058.00 HOSE VAC CLEAR VINYL 2-58"LG

VX200 WATER TANK ASSEMBLY

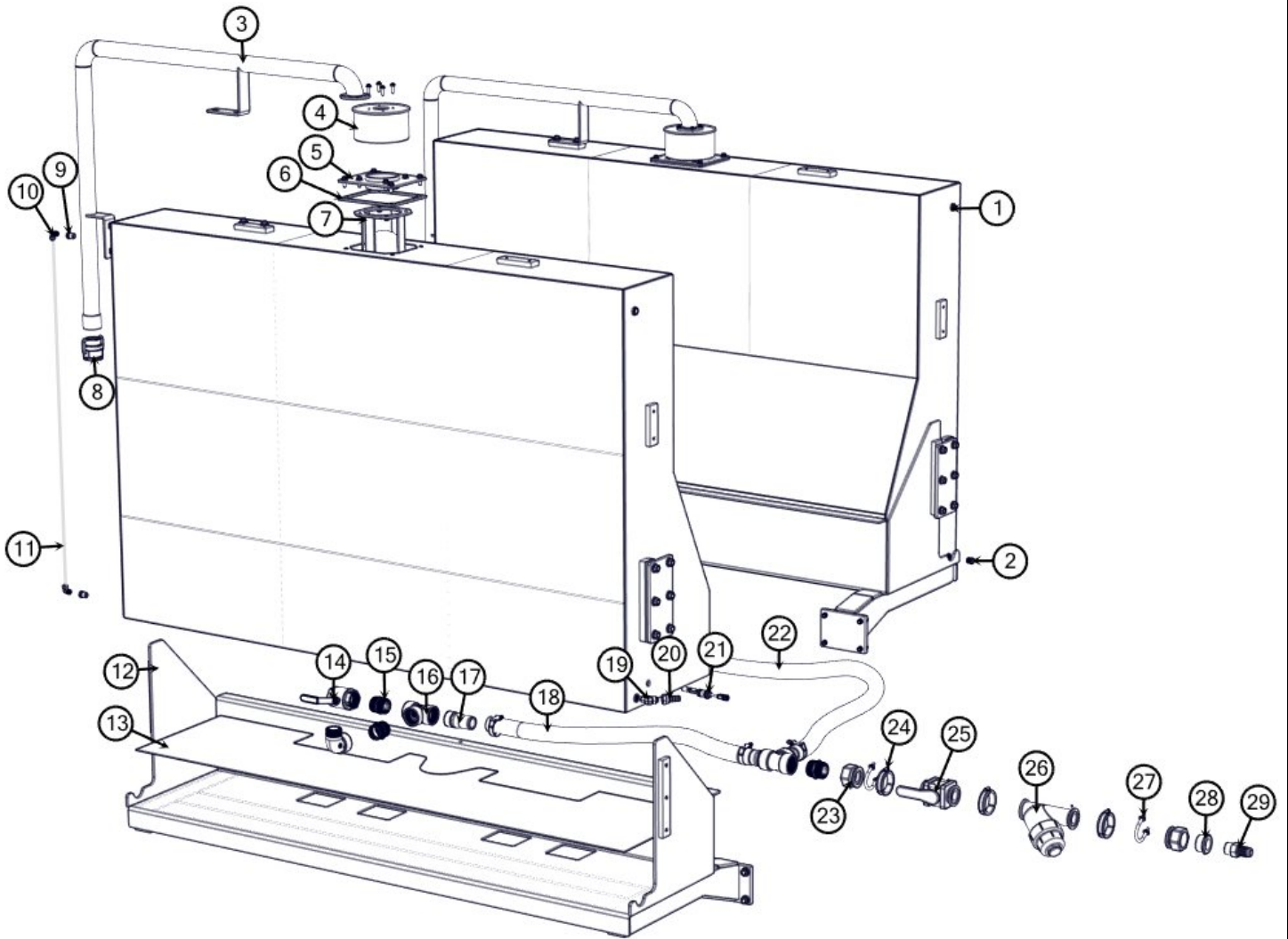

VX200 WATER TANK ASSEMBLY

BOM ID	Qty	Name
1	2	8093820 TANK, WATER 400 GALLON
2	3	T405062 PLUG, 1/2" NPT HEX SOCKET HD
3	2	8093821 WELDMENT, QUICKFILL 400 GAL
4	2	8094105 WELDMENT, QUICKFILL ATTACHMENT
5	2	8092757 WELDMENT, FLANGE SADDLE TANK
6	2	8092760 GASKET, INLET SADDLE TANK
7	2	8092764 ASSEMBLY, FLOAT BALL SADDLE TN
8	2	8031219 COUPLING, 2" ALUM MP X FCAMLOCK
9	4	T400024 ADAPTER STR -8MP -6FP STEEL GALV
10	4	T320310 6HOSE_6MP
11	2	8093015-050.00 TUBE, VINYL 3/8"ID X 1/2"OD
12	2	8092650 SADDLE TANK ATTACHMENT
13	2	8094135 STRIP, ISOLATOR SADDLE TANK
14	2	8090233 VALVE, BALL 2" W/LEVER HANDLE
15	4	8093019 FITTING, NIPPLE PIPE 2" SHORT
16	3	8090204 FITTING, TEE 2" BANJO
17	4	T410115 FITTING, 2"MNPT - 2"BARB STEEL
18	1	8043398-050.00 HOSE VAC CLEAR VINYL 2"- 50"LG
19	1	T401561 ELBOW, 45 1/2"MP - 3/4"MJ
20	1	8030525 FITTING, PUSHLOK #12
21	1	8090896 SWITCH, WATER LEVEL (HORIZ)
22	1	8043398-091.00 HOSE VAC CLEAR VINYL 2" - 91"LG
23	2	8030996 MANIFOLD, 2" BANJO FEMALE ADAPTOR
24	3	8031000 CLAMP, 2" BANJO WORM
25	1	8030998 VALVE, 2" BALL-MANIFOLD
26	1	8031001 STRAINER, Y 2" FLANGE 80 MESH
27	2	8031373 CLAMP, U-BOLT 2.5" EXHAUST
28	1	8043843 REDUCER, 2"MP - 1 1/4"FP GALV
29	1	8041312 FITTING, 1 1/4"MP - 1 1/4"HB

VX200 WATER REEL ASSEMBLY

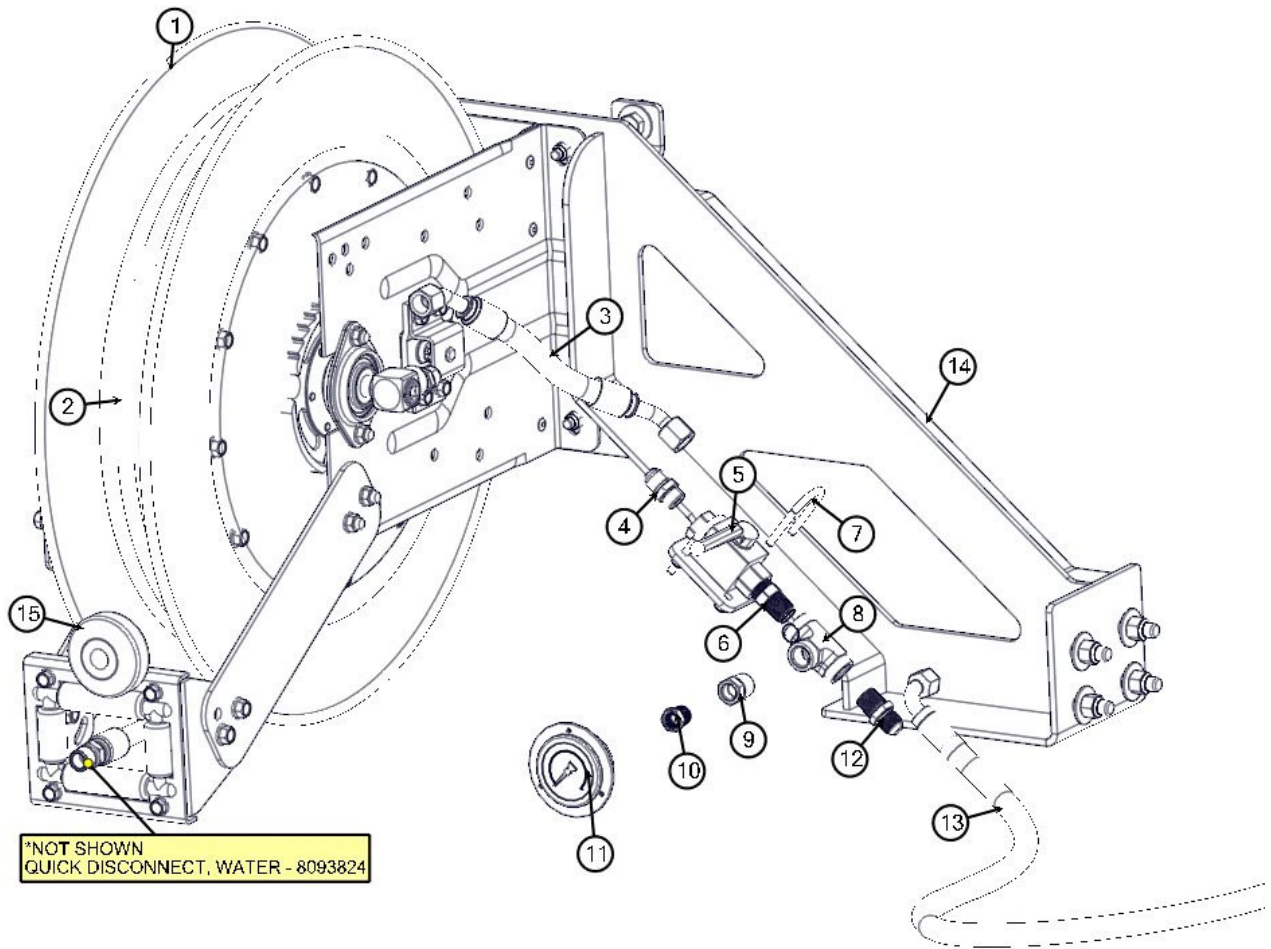

VX200 WATER REEL ASSEMBLY

BOM ID	Qty	Name
1	1	8092722 REEL ONLY SPRGDRVN 1/2" X 75'
2	1	8094735 HOSE, REEL 1/2"-75'
3	1	Tube_28-8093768-001
4	1	T400140 UNION, 8MB-8MJ
5	1	8031197 VALVE, BALL 1/2" 3000 PSI MIN
6	1	T404020 UNION, 8MP-8MP
7	2	U010017 U-BOLT, .250-20
8	1	T402130 TEE, 8FP-8FP-8FP
9	1	T400024 REDUCER, 1/2"MP-3/8"FP
10	1	T400023 REDUCER, 6MP-4FP
11	1	8030372 GAUGE, 5000 PSI 2.5"LF CBM
12	1	T400040 UNION, 8MP-8MJ
13	1	8094533 HOSE ASSY VAC 8-210" ST-90
14	1	8094450 VERTICAL WATER REEL MOUNT WELDMENT
15	1	8094854 BALL STOPPER 3/8"-100' REEL

*NOT SHOWN

1 - 8093824 FITTING, QD WATER 1/2"F - 1/2"FP

VX200 TOOLS ASSEMBLY

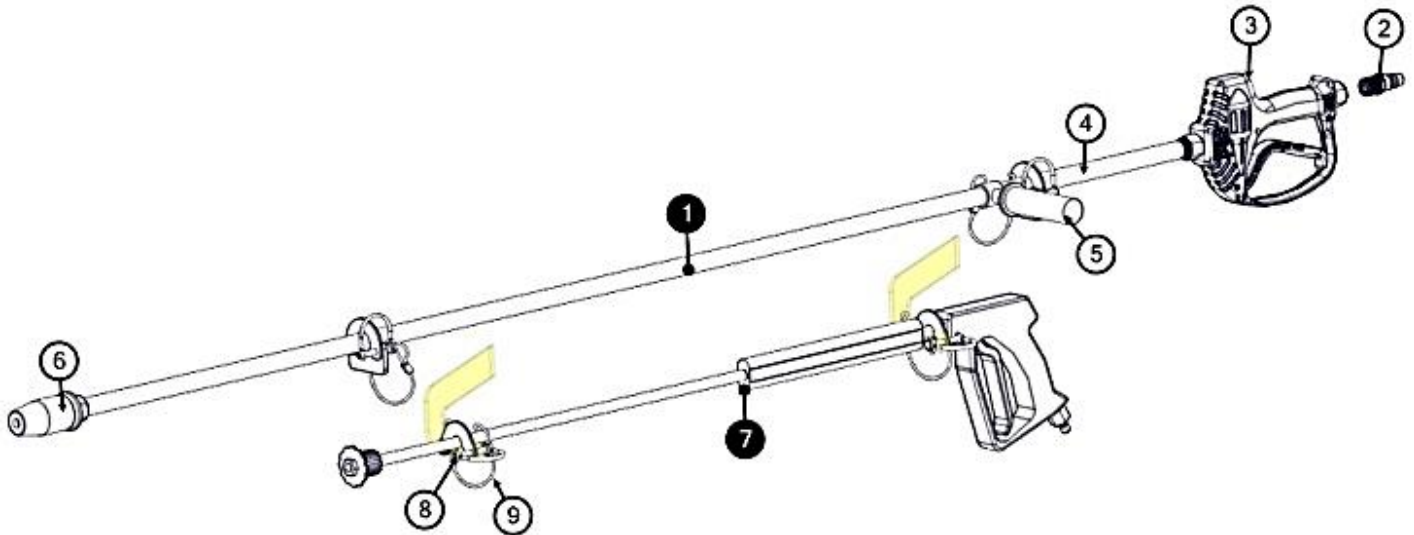

BOM ID	Qty	Name
1	1	8093810 LANCE ASSEMBLY 72"
2	1	8093823 FITTING, QD WATER 1/2"M-1/2"MP
3	1	8093263 GUN, LANCE
4	1	8093261 ROD, LANCE
5	1	8093262 HANDLE, LANCE
6	1	8093109 NOZZLE, TURBO 1/2"FPT
7	1	8094780 VAC TOOL WASH WAND COMPLETE
8	4	8093706 PIN LINCH 1/4" X 1 3/4" W/WIRE LOCK
9	4	8093703 CABLE, LANYARD 11"LG

PAGE LEFT BLANK

VX200 BOOM TURRET ASSEMBLY

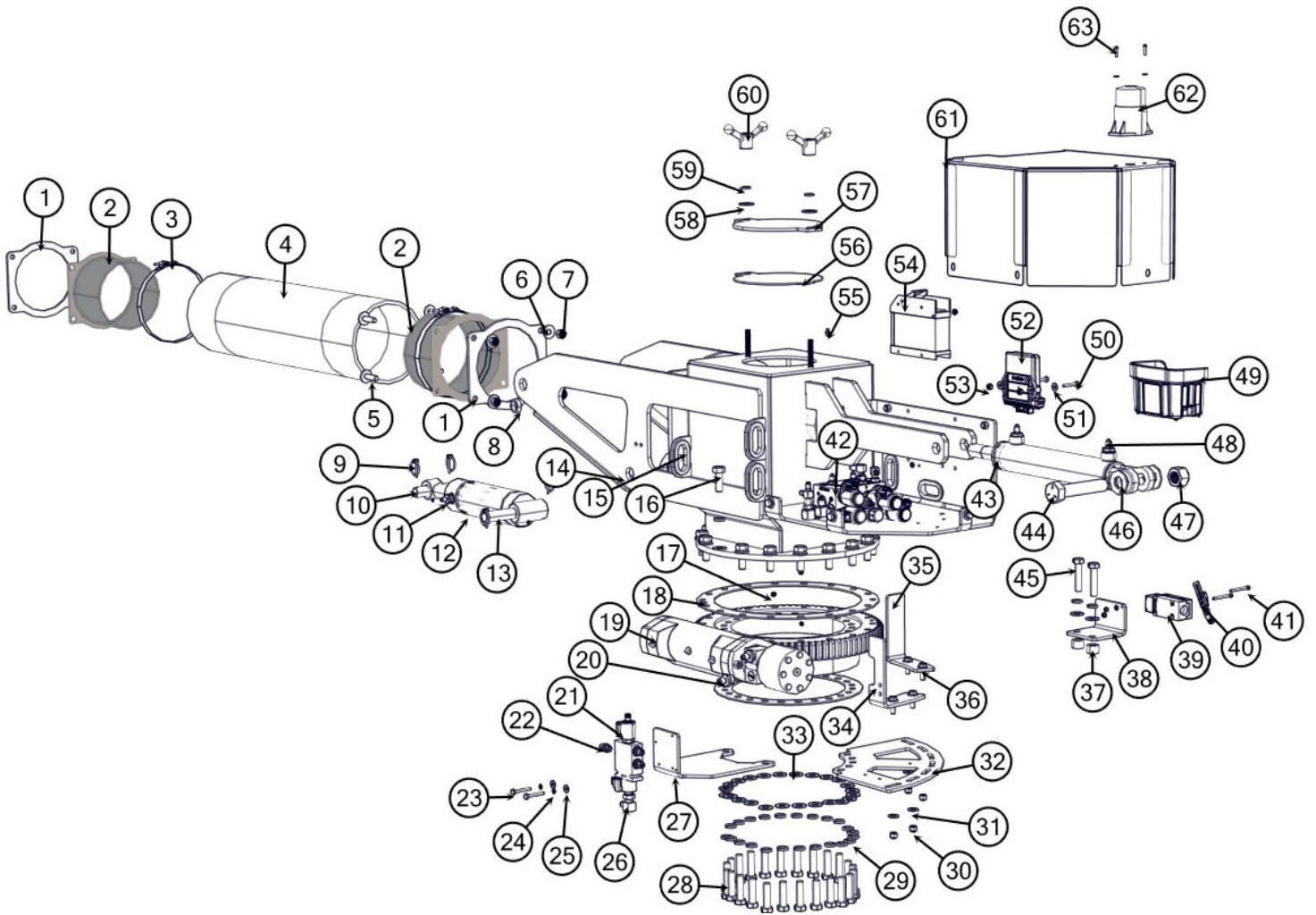

VX200 BOOM TURRET ASSEMBLY

BOM ID	Qty	Name
1	2	8095790 GASKET, BOOM 8" HOSE ADAPTER
2	2	8095767 WELDMENT, BOOM 8" HOSE ADAPTER
3	2	8092896 CLAMP, T-BOLT 8" HOSE
4	1	8092966-032.50 HOSE AG SUCTION 8" X 32.50"LG
5	4	U000880 SCREW, HC .500-13 X 2.00 ZP G5
6	8	U200100 WASHER, FLAT .500 ZP
7	4	U160018 NUT, LOCK .500-13 NY ZP
8	2	8094000 BUSHING, BRONZE 1.25 X 1.00 X .375 CUT
9	4	U340050 PIN LINCH 3/16 X 1 9/16 ZP
10	1	8041990 BOOM PIVOT CYL ROD PIN
11	2	T400611 REDUCER, 8MB - 4MJ
12	1	8046597 CYLINDER, HYD BOOM 3 X 6
13	1	8041977 BOOM PIVOT CYL BASE PIN
14	1	8095752 WELDMENT, BOOM 8" TURRET
15	5	8042812 GROMMET, 2"ID X 3"OD X 1/4"WOG
16	16	U001195 SCREW, HC .625-11 X 1.75 ZP G5
17	2	T500020 FITTING, GREASE .125 STR 1/8"-27 NPT
18	1	8043780 GASKET, BOOM BRG TOP BIG 16.5"
19	1	8042231 BEARING, BOOM HYD ROT ASSY
20	2	T400035 REDUCER, 10MB - 6MJ
21	1	8094016 MANIFOLD, HYD BOOM 6" ASSEMBLY
22	3	T400037 UNION, 6MB-6MJ
23	2	U000110 SCREW, HC .250-20 X 1.75 ZP G5
24	2	U210020 WASHER, LOCK .250 ZP
25	2	U200020 WASHER, FLAT .250 ZP
26	1	T401250 ELBOW, 90 6MB - 6MJ
27	1	8042344 BOOM HYD MANIFOLD MTG PLATE
28	24	U001210 SCREW, HC .625-11 X 2.25 ZP G5
29	42	U210140 WASHER, LOCK .625 ZP
30	4	U110060 NUT, ST .375-16 ZP G2
31	8	U200060 WASHER, FLAT .375 ZP
32	1	8042351 BOOM ROTATION STOP BASE PLATE

BOM ID	Qty	Name
33	42	U200150 WASHER, FLAT .625 ZP SAE HARD
34	1	8042357 BOOM ROTATION STOP BRACKET
35	1	8042359 BOOM ROTATION STOP BRACKET OPP
36	4	U000440 SCREW, HC .375-16 X 1.25 ZP G5
37	2	8042376 SPACER, LIMIT SWITCH BRACKET BOOM
38	1	8042360 BRACKET, BOOM LIMIT SWITCH
39	1	8042431 SWITCH, LIMIT BOOM
40	1	8042432 SWITCH LIMIT BOOM ADJ LEVER
41	2	U010016 SCREW, HSH #10-24 X 2.25
42	1	8094056 MANIFOLD, BOOM UPPER ASSEMBLY
43	1	8095770 CYLINDER, 2" X 10" 1 1/8" ROD
44	1	U001570 SCREW, HC 1-8 X 5.00 ZP
45	2	U001240 SCREW, HC .625-11 X 2.75 ZP G5
46	2	U200170 WASHER, FLAT 1.00
47	1	U120060 NUT, LOCK 1.00-8 NY ZP G2
48	2	T400611 REDUCER, 8MB - 4MJ
49	1	8094018 TRANSMITTER, MINI MBT BOOM 6"
50	2	U000100 SCREW, HC .250-20 X 1.50 ZP G5
51	4	U200020 WASHER, FLAT .250 ZP
52	1	8094017 RECEIVER, CAN 2 BOOM W/ ANTENNA
53	2	U120000 NUT, LOCK NY .250-20 ZP G2
54	1	8092952 CONTROLLER IFM CAN (BOOM)
55	1	T500030 FITTING, GREASE .125 NPT STR
56	1	8095788 GASKET, BOOM 8" TURRET CLEANOUT
57	1	8095789 PLATE, BOOM 8" TURRET CLEANOUT
58	2	U200100 WASHER, FLAT .500 ZP
59	2	U210100 WASHER, LOCK .500 ZP
60	2	8041594 HANDLE, WING REV FLOW CYC/FILTER
61	1	8094006 WELDMENT, BOOM COVER NO SWITCH
62	1	8043139 LIGHT, STROBE LED DEUTSCH
63	2	U030809 SCREW, PAN HD PHIL 10-24 X .75

*NOT SHOWN:
HARNES, BOOM VX200 - X200201

VX200 BOOM MANIFOLD ASSEMBLY

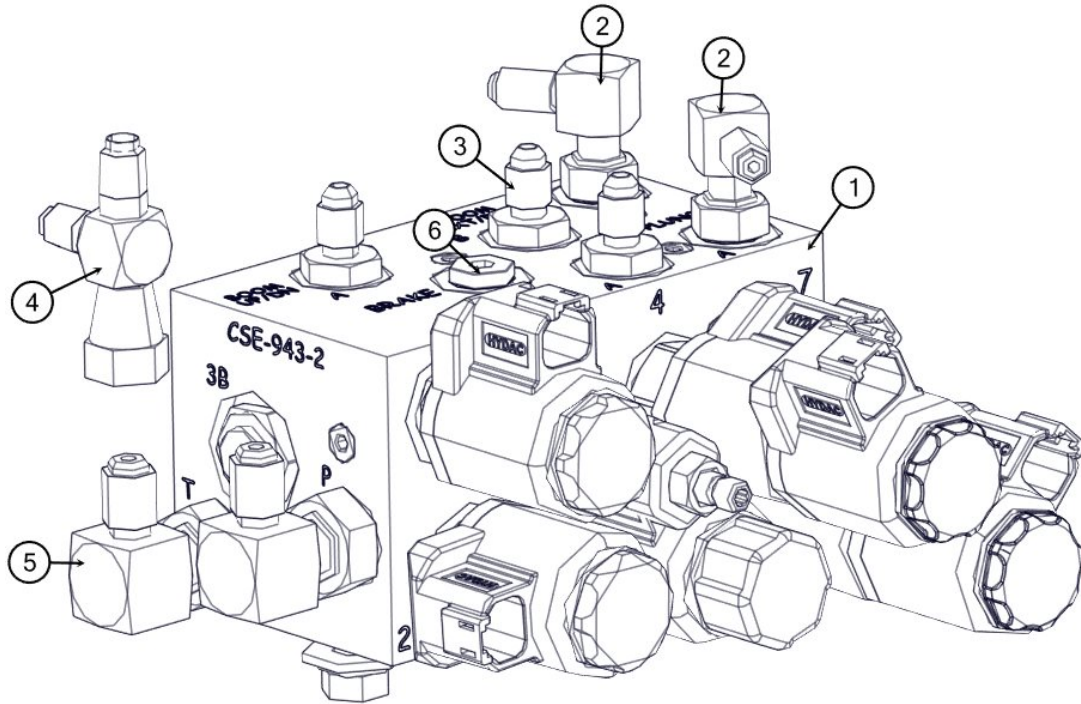

BOM ID	Qty	Name
1	1	8094056 MANIFOLD, BOOM UPPER ASSEMBLY
2	2	T401240 ELBOW, 90 6MB (ADJ) - 4MJ
3	3	T400550 REDUCER, 6MB-4MJ
4	1	T402153 TEE, 6FJ - 6MJ - 6MJ
5	2	T401250 ELBOW, 90 6MB - 6MJ
6	1	T405092 PLUG, 3/8"MB-HEX SOCKET HOLLOW

VX200 BOOM EXTENSION ARM ASSEMBLY

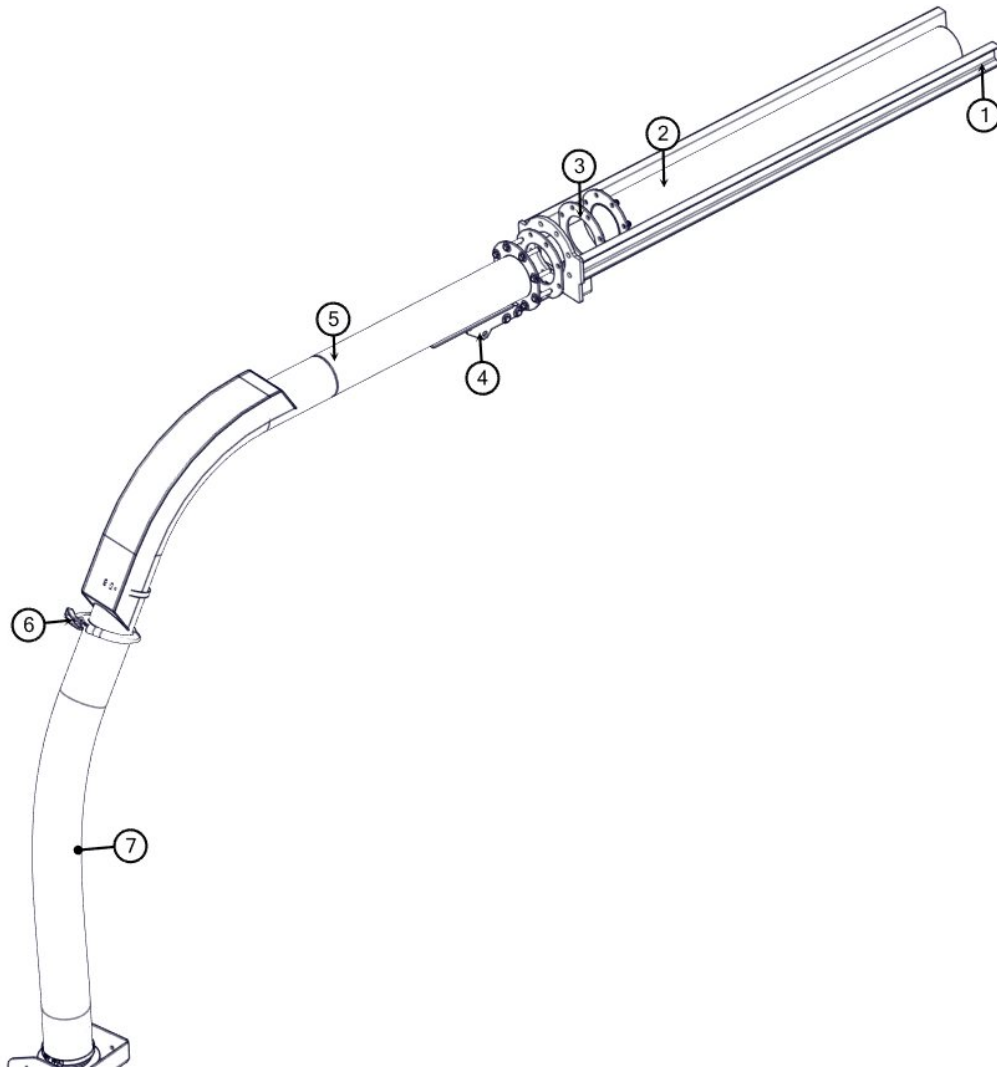

BOM ID	Qty	Name
1	1	8047655 BOOM - EXTENSION ARM WELDMENT
2	1	8092375 WELDMENT, BOOM EXTENSION TUBE
3	2	8092939 GASKET, BOOM
4	1	8091620 WELDMENT, PIVOT END 6" BOOM
5	1	8093388 WELDMENT, BOOM EXTENSION 6"
6	1	8092944 CLAMP, QUICK 6"
7	1	8093704 ASSEMBLY, BOOM EXTENSION 6"

VX200 BOOM EXTENSION ARM ASSEMBLY

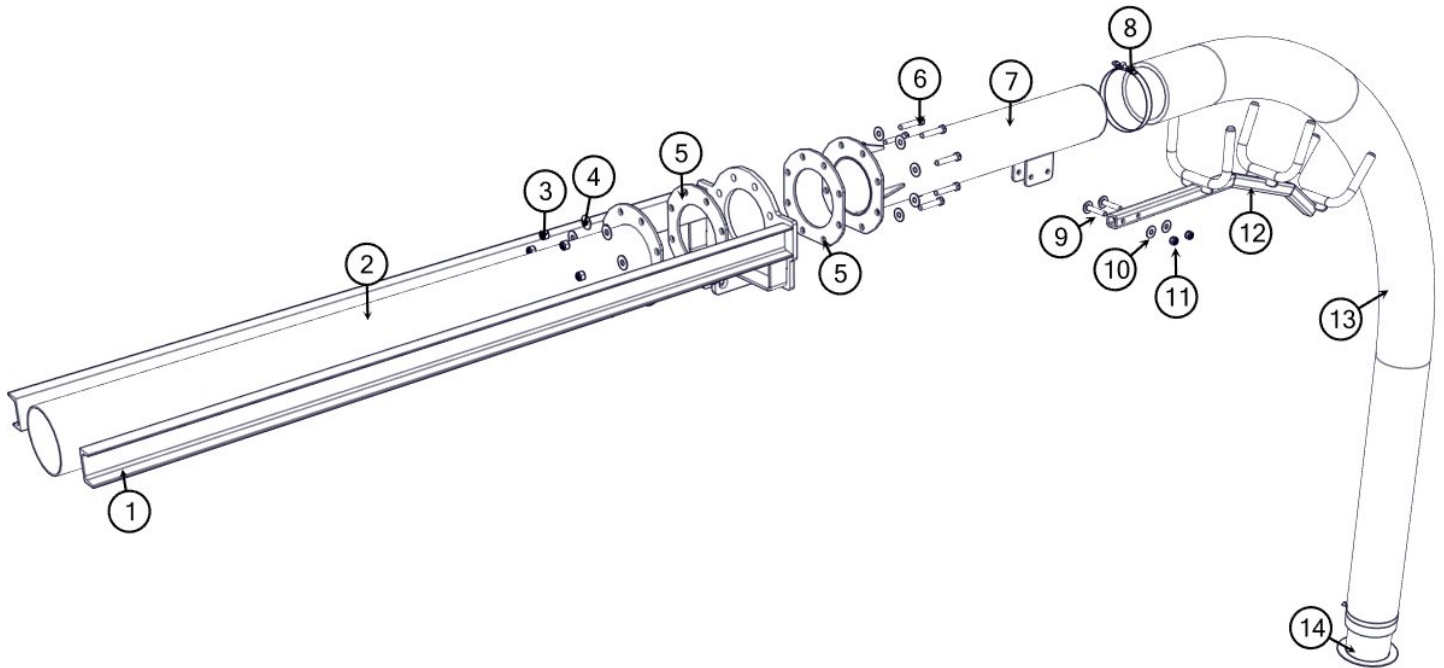

BOM ID	Qty	Name
1	1	8095779 WELDMENT, BOOM 6" EXTENSION
2	1	8092375 WELDMENT, BOOM EXTENSION
3	8	U160018 NUT, LOCK .500-13 NY ZP
4	16	U200100 WASHER FLAT .500 ZP
5	2	8092939 GASKET, BOOM
6	8	U000920 SCREW, HC .500-13 X 2.75 ZP G5
7	1	8095782 WELDMENT, BOOM 6" EXTENSION LG
8	2	8043198 CLAMP HOSE T-BOLT 700
9	2	U000920 SCREW, HC .500-13 X 2.75 ZP G5
10	4	U200100 WASHER FLAT .500 ZP
11	2	U160018 NUT, LOCK .500-13 NY ZP
12	1	8097041 WELDMENT, CRADLE BOLT-ON
13	1	8096849-120.00 HOSE, MATERIAL HANDLING, 6" X 120" LONG
14	1	8093018 WELDMENT, BOOM HOSE CONNECTION

VX200 HOTBOX ASSEMBLY

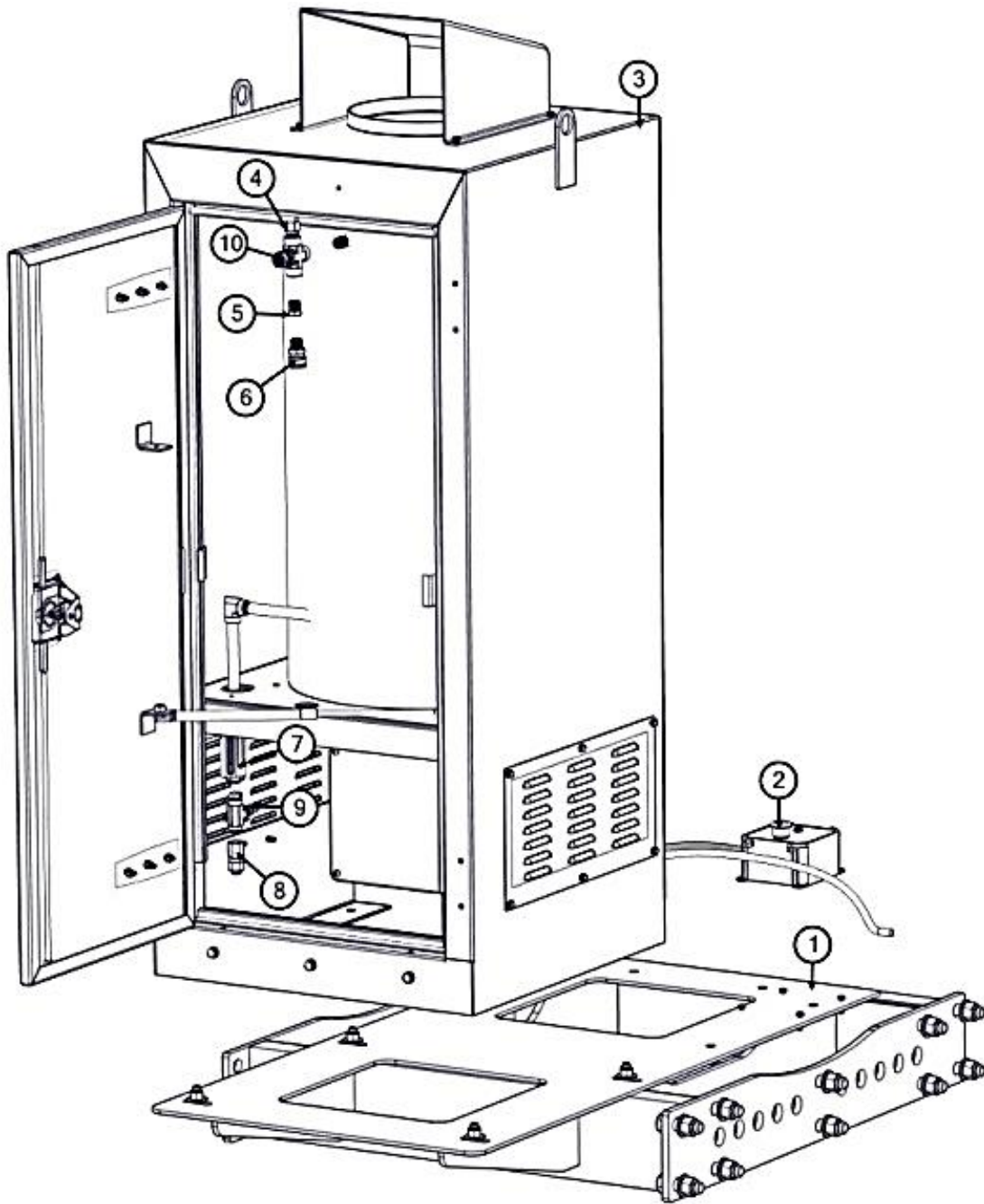

VX200 HOTBOX ASSEMBLY

BOM ID	Qty	Name
1	1	8093747 WELDMENT, SKID HOTBOX VX200
2	1	8093136-01 HOTBOX ESTOP
3	1	8093136 HOTBOX, DYNABLAST 420K
4	1	8093136-02 HIGH LIMIT (110C)
5	1	8093136-03 BUSHING, 1/2" X 3/8"
6	1	8093136-04 QUICK COUPLER, FEMALE 3/8"
7	1	8093136-05 FLOW SWITCH
8	1	8093136-06 QUICK COUPLER, MALE 3/8"
9	1	8093136-07 RELIEF VALVE
10	1	8093136-10 TEMPERATURE SENSOR RTD

***NOT SHOWN**

8093136-08	1	IGNITER
8093136-09	1	COIL
8093136-10	1	ELECTRODE KIT
X200204	1	HARNESS, HOTBOX

PAGE LEFT BLANK

WARRANTY RETURN GOODS POLICY

LIMITED WARRANTY

The Manufacturer warrants its products to be free from defects in material and workmanship for a period of twelve months from the date of shipment from the factory. The Manufacturer shall not be responsible for any damage resulting to or caused by its products by reason of installation, improper storage, unauthorized service, alteration of the products, neglect or abuse, or use of the product in a manner inconsistent with its design. The warranty does not extend to any component parts not manufactured by Manufacturer; however, Manufacturer's warranty herein shall not limit any warranties made by manufacturers of component parts which extend to Buyer.

Claims for defects in material and workmanship shall be made in writing to Manufacturer within ten days of discovery of defect. Manufacturer may either send a service representative or have the product returned to its factory at Buyer's expense for inspection. Upon notification of defect, Manufacturer will issue a return goods authorization number to Buyer. The return goods authorization number must accompany the product returned. If judged by the Manufacturer to be defective in material or workmanship, the product will be replaced or repaired at the option of the Manufacturer, free from all charges except authorized transportation. Buyer shall be responsible for all maintenance services consisting of lubrication and cleaning of equipment, replacing expandable parts, making minor adjustments, and performing operating checks, all in accordance with procedures outlined in Manufacturer's maintenance literature.

THE FOREGOING WARRANTY IS IN LIEU OF ALL OTHER WARRANTIES AND NO REPRESENTATIONS, GUARANTEES, OR WARRANTIES, EXPRESS OR IMPLIED, (INCLUDING BUT NOT LIMITED TO A WARRANTY OF MERCHANTABILITY OR FITNESS FOR A PARTICULAR PURPOSE), ARE MADE BY THE MANUFACTURER IN CONNECTION WITH THE MANUFACTURE OR SALE OF ITS PRODUCTS. NO EMPLOYEE, DISTRIBUTOR, OR REPRESENTATIVE IS AUTHORIZED TO CHANGE THIS WARRANTY ON BEHALF OF MANUFACTURER.

THE REMEDIES OF BUYER SET FORTH HEREIN ARE EXCLUSIVE AND ARE IN LIEU OF ALL OTHER REMEDIES. THE LIABILITY OF MANUFACTURER WHETHER IN CONTRACT, TORT, UNDER ANY WARRANTY, OR

OTHERWISE SHALL NOT EXTEND BEYOND ITS OBLIGATION TO REPAIR OR REPLACE, AT ITS OPTION ANY PRODUCT OR PART FOUND BY MANUFACTURER TO BE DEFECTIVE IN MATERIAL OR WORKMANSHIP. MANUFACTURER SHALL NOT BE LIABLE FOR COST OF INSTALLATION AND/OR REMOVAL OR BE RESPONSIBLE FOR DIRECT, INDIRECT, SPECIAL OR CONSEQUENTIAL DAMAGES OF ANY NATURE.

GENERAL RETURNS OF MERCHANDISE

1. All returns must be pre-authorized
 - A. Please call our parts department for an RGA number
 - B. Please include RGA number on the outside of box
 - C. Include any required paper work or special instructions
 - D. Items returned without an RGA number will not be accepted
2. All returns are subject to a 20% restock charge.
3. Special items are non-returnable
 - A. Non-stock parts
 - B. Custom parts
 - C. If you are unsure about a parts status when ordering, ask your McLaughlin representative if the item fits on of the above conditions.
4. Items must be returned within thirty days of original order date.
5. Items not returned within 30 days from the date of RGA is issued will not be accepted.
6. The item(s) must be in new condition. Used item(s) are not returnable.

FOR SCHEMATICS SEE: www.mclaughlinunderground

**CALIFORNIA
Proposition 65 Warning**

Diesel engine exhaust and some of its constituents are known to the State of California to cause cancer, birth defects, and other reproductive harm.

**CALIFORNIA
Proposition 65 Warning**

Battery posts, terminals, and related accessories contain lead and lead compounds, chemicals known to the State of California to cause cancer and reproductive harm. Wash hands after handling.