



Providing Solutions Since 1921

2006 Perimeter Road. Greenville, SC 29605

Toll Free: 800/435-9340 – Phone: 864/277-5870

Fax: 864/235-9661 – Website address: www.mclaughlinunderground

Email address: mmole@mightymole.com

PARTS MANUAL

Vermeer/McLaughlin

VX50-500

VX50-500LT

Part # E850511

SERIAL NUMBER – VX5062014615 TO V5H1015151615

11/11/2015

2015 by McLaughlin Group, Inc. REV. 1

All rights reserved. No part of this manual may be reproduced in any form, or by any means without prior written permission of McLaughlin Group, Inc.

Table of Contents

DECAL LAYOUT	6
TRAILER	13
TRAILER ASSEMBLY.....	15
ELECTRICAL ASSEMBLY.....	17
REMOTE DRAIN	19
FUEL TANK ASSEMBLY.....	21
HYDRAULIC PUMP	25
HYDRAULIC PUMP ASSEMBLY.....	27
HYDRAULIC TANK RAISE/LOWER.....	29
HYDRAULIC DOOR OPEN/CLOSE.....	31
HYDRAULIC ARM ASSEMBLY	33
SPOIL TANK/DOOR ASSEMBLY.....	35
FILTRATION ASSEMBLY.....	37
POWERPACK LAYOUT.....	39
CONTROL BOX ASSEMBLY.....	41
ENCLOSURE ASSEMBLY.....	43
ENGINE ASSEMBLY.....	45
BLOWER LAYOUT	47
BLOWER ASSEMBLY.....	49
BLOWER LAYOUT	53
BLOWER ASSEMBLY (4" VALVE)	55
WATER PUMP ASSEMBLY.....	59
WATER TANK 125GAL ASSEMBLY.....	61
WATER TANK 50GAL ASSEMBLY.....	63
WATER REEL/ANTIFREEZE ASSEMBLY.....	65
VAC TOOLS.....	67
SUCTION TOOL ASSEMBLY.....	69
ROTARY LANCE ASSEMBLY.....	71
WASH WAND ASSEMBLY.....	73
HOT BOX ASSEMBLY.....	75
STRONGARM ASSEMBLY.....	77
ARROWBOARD ASSEMBLY.....	79
ROOT BLOWER MANUAL	82

SYSTEM OPERATIONS SPECIFICATIONS

PART	PART #	FIRST 100 HOURS	EVERY 500 HOURS	EVERY 3000 HOURS
ENGINE OIL	15W40 CJ-4/ACEA E9/ECF-3		X	
ENGINE COOLANT	50/50 mixture of PROPYLENE GLYCOL AND WATER that meets ASTM D6210 specifications	✓Daily		X
OIL FILTER (PERKINS)	8091505		X	
FUEL FILTER (primary)(PERKINS)	8092475		X	
AIR FILTER (PERKINS)	8091506	✓Daily	X	
FUEL-WATER SEPARATOR FILTER	8047266-01		X	
HYDRAULIC OIL	INDUSTRIAL TYPE HYDRAULIC FLUID	✓Daily		
BLOWER OIL	INDUSTRIAL TYPE, HEAVY DUTY, NON-DETERGENT MOTOR OIL	✓Daily, X	X	
WATER PUMP OIL	GENERAL PUMP SERIES 100 OIL or SAE30, NON- DETERGENT, MOTOR OIL	✓Daily		
DIESEL PARTICULATE FILTER				X

HYDRAULIC TEMPERATURE RANGE	0-120°F (-18°-40°C) SAE 10 GRADE HYDRAULIC OIL or DEXTRON II ATF 32-175°F (0-80°C) SAE 20 GRADE HYDRAULIC OIL 3QTS (2.8L)
--------------------------------	---

BLOWER TEMPERATURE RANGE	30°F (-1°C) AND UNDER SAE 20 30-90°F (-1-32°C) SAE 30 90°F (32°C) AND ABOVE SAE 40
-----------------------------	---

****WATER PUMP – (Remove fill cap and fill crankcase to dot on oil gauge window.)

****Refer to Component Manual specific Component Specifications.

GREASE GUN LUBE POINTS



STRONGARM GREASE POINT



ENGINE GREASE POINT

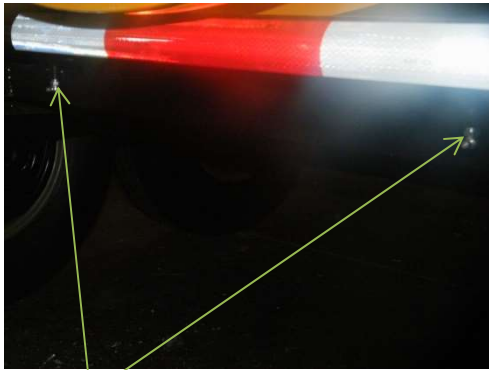

TANK PIVOT TUBE GREASE POINT



4-WAY VALVE GREASE POINT

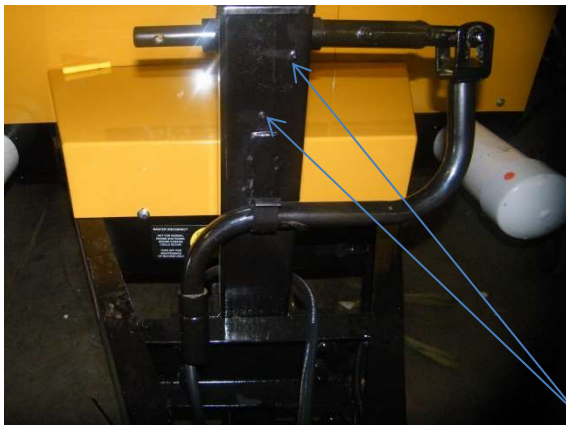

TRAILER JACK GREASE POINT

DECAL LAYOUT

WARNING



ENTANGLEMENT HAZARD
Rotating pulleys and belts could cause serious injury.
Do not operate without guards in place.

J200445

J200445

WARNING



Hot fluid under pressure.
Hot coolant and steam can burn or scald.
NEVER open when hot.

J200435

J200435

WARNING



Moving parts.
Death or serious injury may result.
Stop engine before servicing.

J200425

J200425



WARNING

NOT A LIFT POINT FOR EQUIPMENT.
Heavy load can fall and cause serious injury or possible death.
Lift equipment at designated points.
See equipment manual(s) for lift points.

8049882



WARNING

Flammable fumes.
Fumes may explode or catch fire.
Keep away from sparks and open flame.

Battery acid.
Battery acid can burn skin and eyes.
Protect face, hands and body when servicing.

J200430

DECAL LAYOUT

WARNING



Read manual.
Death or serious injury may result.
Read and understand
all safety and operating instructions
BEFORE operating any equipment.

J200420

J200420

WARNING



Electricity, or Gas
Explosion Can Kill



Locate Utilities
Call 811

J200210

J200210



WARNING



ENTANGLEMENT HAZARD
Rotating pulleys and belts
could cause serious injury.
Do not operate
without guards in place.

J200445

J200445

WARNING



Moving parts.
Death or serious injury
may result.
Stop engine
before servicing.

J200425

J200425

**PLUNGER IN
FOR VACUUM**

**ALIGN GROOVE
ON SHAFT FOR
NEUTRAL**

**PLUNGER OUT
FOR PRESSURE**

J200249

J200249

⚠ DANGER



**EXPLOSION HAZARD!
CONTENTS UNDER
PRESSURE!**
Relieve tank pressure
before opening.
Failure to comply will
result in death or
serious injury.

J200423 rev.1

J200423



⚠ WARNING

Pinch point.
Serious injury may result.
Keep hands clear
when closing door
or lowering tank.

J200455

J200455



⚠ DANGER



SUFFOCATION HAZARD.
Vacuum hoses will cause
death or serious injury.
Keep hoses and tools
away from face and body.

J200415



⚠ WARNING

CRUSHING WEIGHT
DEATH OR SERIOUS INJURY COULD
RESULT
EMPTY TANK BEFORE SERVICING
ALWAYS INSTALL SAFETY BAR
WHEN WORKING ON RAISED TANK

J200458

J200458

⚠ DANGER



**EXPLOSION HAZARD!
CONTENTS UNDER
PRESSURE!**
Relieve tank pressure
before opening.
Failure to comply will
result in death or
serious injury.

J200423 rev.1

J200423

⚠ DANGER



SUFFOCATION HAZARD.
Vacuum hoses will cause
death or serious injury.
Keep hoses and tools
away from face and body.

J200415



⚠ WARNING

**FIRE OR EXPLOSION
POSSIBLE.**
Do not vacuum
flammable or
combustible
substances.

J200473

J200473

⚠ DANGER



Crushing weight.
Spoil and door will cause
death or serious injury.
Unlock door only
under vacuum.
Stay away from door
when dumping.

J200410

WARNING



Flammable liquid.
Fuel and fumes can explode or catch fire.
Turn off engine **BEFORE** fueling.
Wipe up spilled fuel immediately.

J200440



WARNING
NOT A LIFT POINT FOR EQUIPMENT.
Heavy load can fall and cause serious injury or possible death.
Lift equipment at designated points.
See equipment manual(s) for lift points.

8049882



DANGER
Crushing weight.
Rolling or tilting trailer will cause death or serious injury.
Chock tires and apply parking brake before operating or servicing.
Do not operate unless attached to the towing vehicle.

J200400

VX50-500 COMPLETE

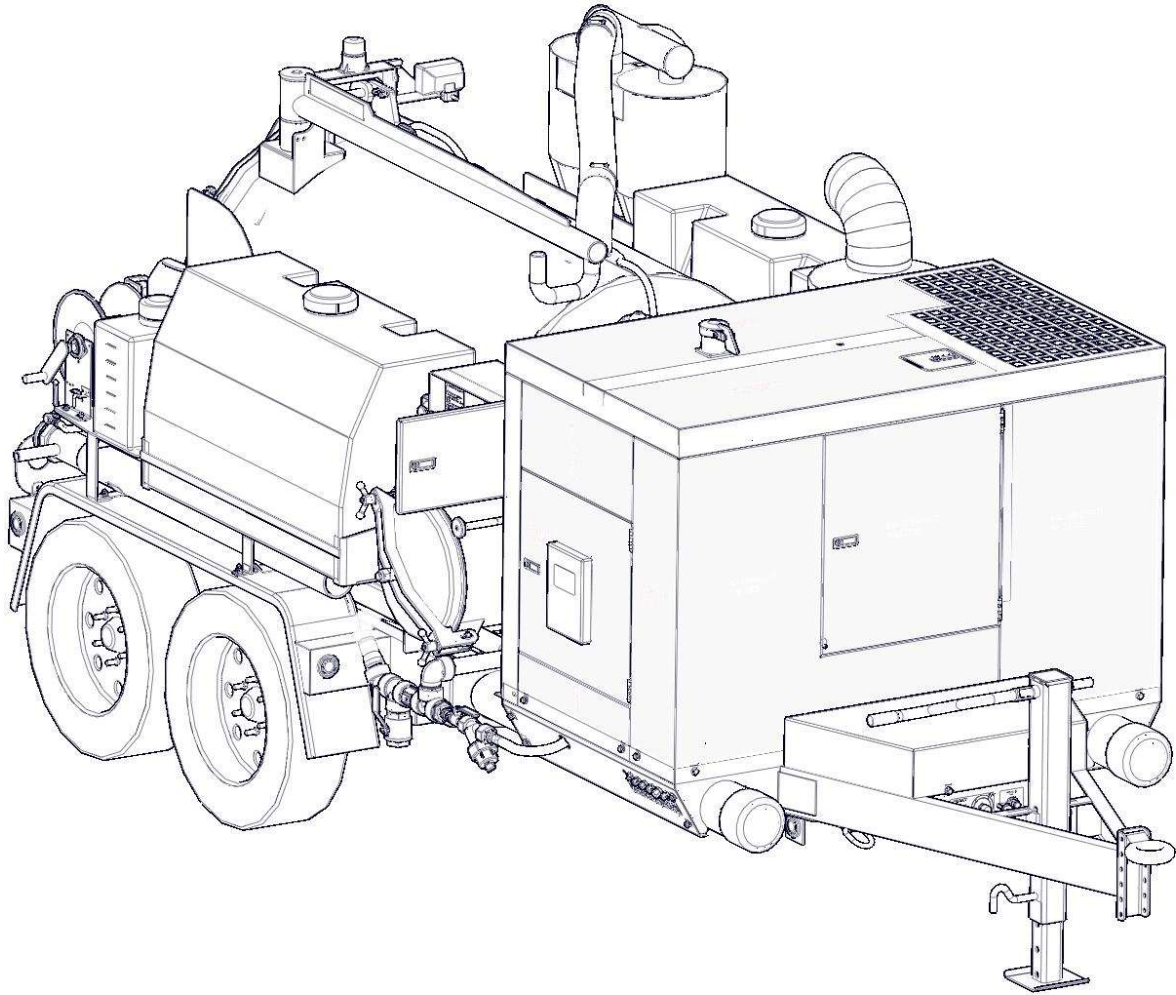

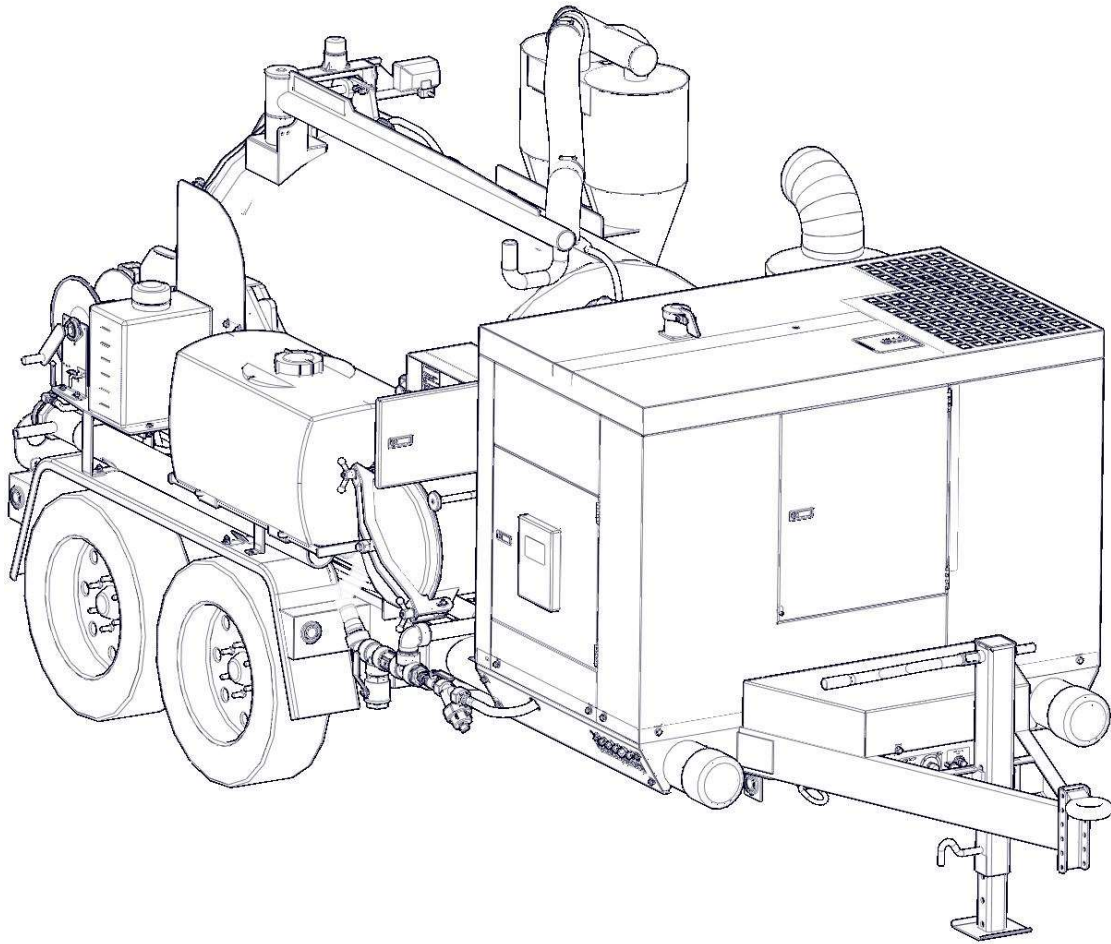

VX50-500 TRAILER

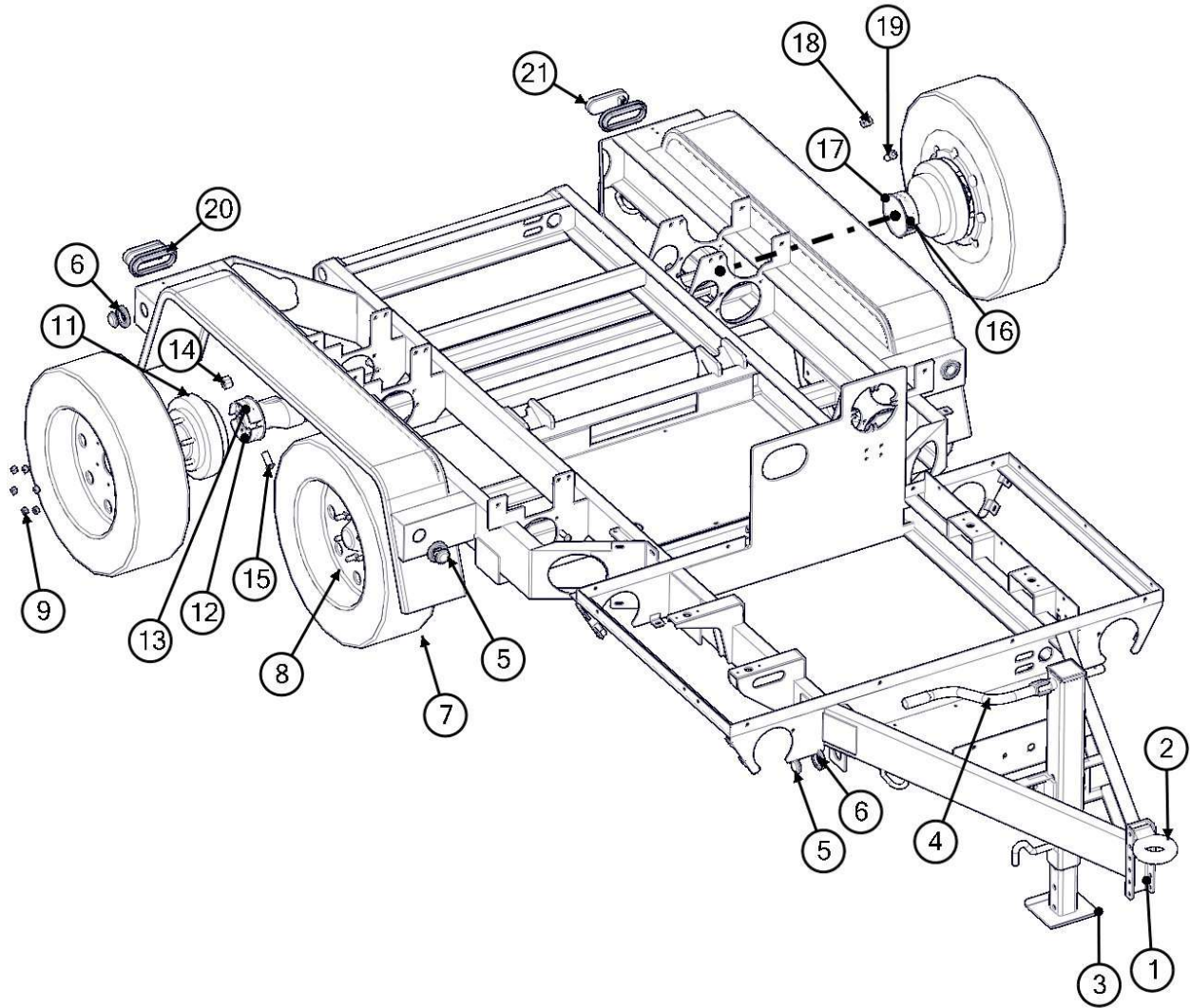

VX50-500 TRAILER

BOM ID	Qty	Name
1	1	8090776 TRAILER, VX50-500
2	1	8043980 PINTLE EYE
3	1	8043548 JACK, MANUAL
4	1	8043984 HANDLE, JACK
5	4	8091468 LIGHT, TRAILER 2" LED AMBER
6	8	8091469 GROMMET, LIGHT 2in RUBBER
7	4	8045708 TIRE,ST235 X 80 R16E
8	4	8045152 WHEEL, R16X6 - 6 LUGS
9	24	8043987 LUG NUT
11	4	8047035 HUB
12	2	8046308 RH BRAKE ASSEMBLY
13	2	8046305 SHOE KIT
14	2	8046304 MAGNET KIT
15	2	8046306 ADJUSTER KIT
16	2	8046307 LH BRAKE ASSEMBLY
17	2	8046305 SHOE KIT
18	2	8046304 MAGNET KIT
19	2	8046306 ADJUSTER KIT
20	2	8091471 GROMMET,LIGHT OVAL LED
21	2	8091470 LIGHT, TRAILER OVAL LED_RED

TRAILER ASSEMBLY

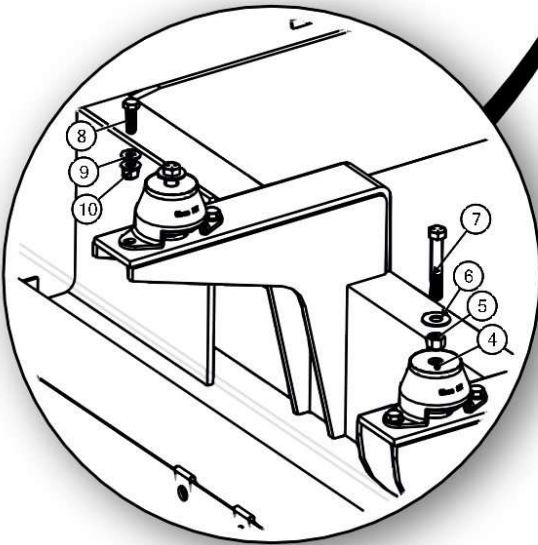
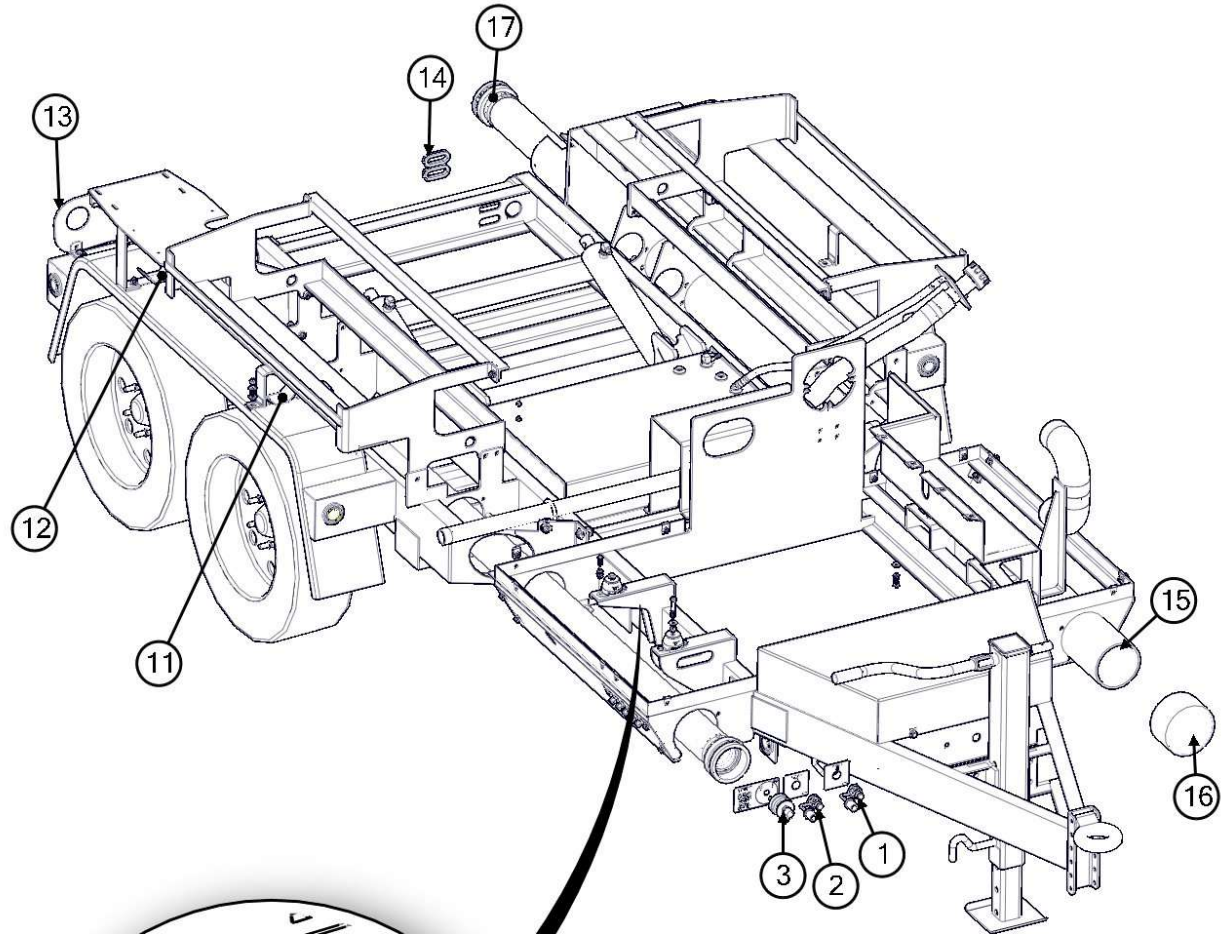

TRAILER ASSEMBLY

BOM ID	Qty	Name
1	1	X400046 TERMINAL, EXTENSION JUMP (RED)
2	1	X400045 TERMINAL, EXTENSION JUMP (BLACK)
3	1	X000245 SWITCH, MASTER DISCONNECT
4	4	8048829 ISOLATOR, POWERPACK
5	4	U120110 NUT, LOCK .375-16 NY ZP
6	4	U200060 WASHER, FLAT 3/8 ZP
7	4	U000540 SCREW, HC 3/8-16 X 2.50 ZP G5
8	8	U000200 SCREW, HC 5/16-18 X 1.00 ZP G5
9	16	U200040 WASHER, FLAT 5/16 ZP
10	8	U110040 NUT, HEX .312-18 NY ZP G2
11	1	8091375 BRACKET, STORAGE REDUCTION TOOL (FRONT)
12	1	8091376 BRACKET, STORAGE REDUCTION TOOL (REAR)
13	1	8091360 DOOR, TOOL STORAGE
14	2	8042812 GROMMET, 2"ID X 3"OD X 1/4"WOG
15	2	8090794 TUBE, HOSE STORAGE
16	2	8030925 CAP, PVC 6"
17	2	8091385 HOSE, KANAFLEX 4 X 176" W/CAMS

* NOT SHOWN

1 8092776 ROD RETAINING ASSEMBLY, HOSE STORAGE

ELECTRICAL ASSEMBLY

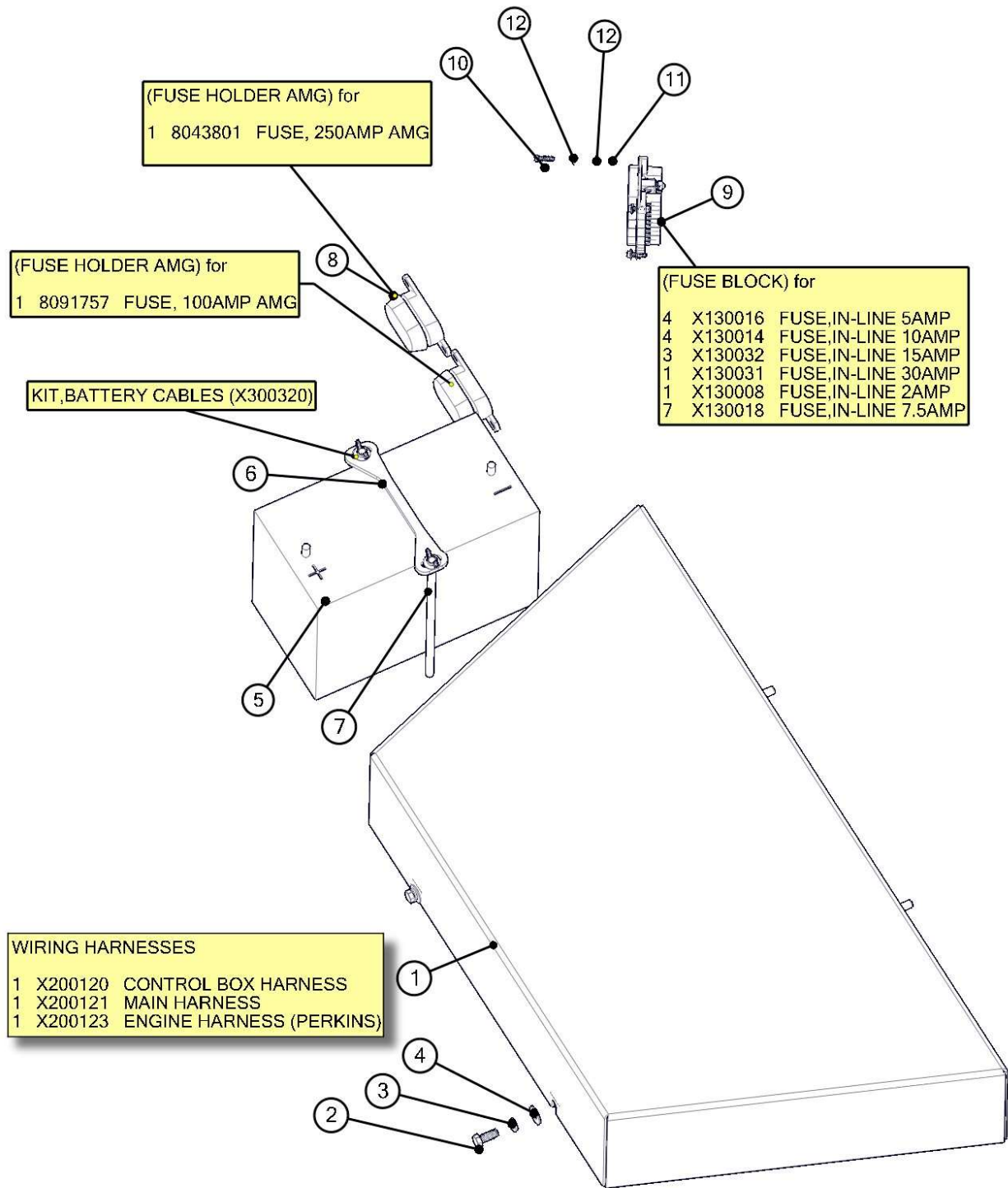

ELECTRICAL ASSEMBLY

BOM ID	Qty	Name
1	1	8090854 COVER, ELECTRICAL
2	2	U000420 SCREW,HC 3/8-16 X 1.00 ZP G5
3	2	U210060 WASHER, LOCK 3/8 ZP
4	2	U200060 WASHER, FLAT 3/8 ZP
5	1	X400050 BATTERY, 31-MHD WORKAHOLIC
6	1	8050016 BATTERY HOLD DOWN
7	2	8043742 BATTERY HOLD DOWN ROD ASSEMBLY
8	2	8043800 FUSE HOLDER AMG
9	1	8043334 FUSE BLOCK 16 POLE
10	4	U030182 SCREW,SHCS M4-0.7 X 20
11	4	U210045 NUT,LOCK 4MM
12	8	U200302 WASHER, FLAT 4MM

REMOTE DRAIN ASSEMBLY

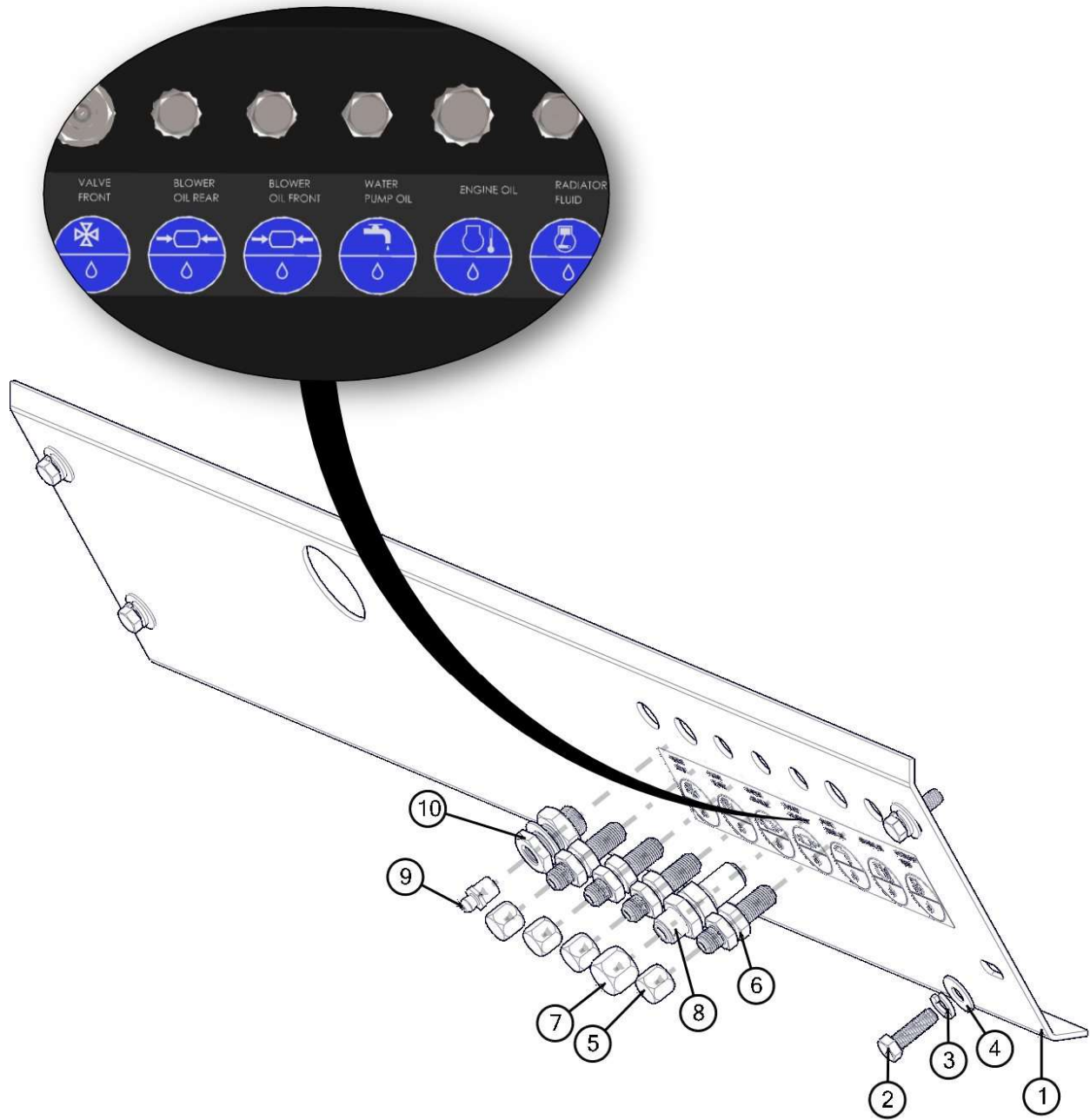

REMOTE DRAIN ASSEMBLY

BOM ID	Qty	Name
1	1	8090796 PANEL, ENCLOSURE OUTER BOTTOM
2	4	U000440 SCREW,HC 3/8-16 X 1.25 ZP G5
3	4	U210060 WASHER, LOCK 3/8 ZP
4	4	U200060 WASHER, FLAT 3/8 ZP
5	4	T405203 CAP, 3/8FJIC HEX HEAD
6	4	T400391 BULKHEAD 6MJ-6MJ
7	1	T405205 CAP, 1/2FJIC HEX HEAD
8	1	T400387 BULKHEAD 8MJ-8MJ
9	1	T500100 FITTING, GREASE 1/4NPT STR
10	1	T400383 BULKHEAD 4FP-4FP
11	1	J200247 DECAL, REMOTE DRAIN

FUEL TANK ASSEMBLY

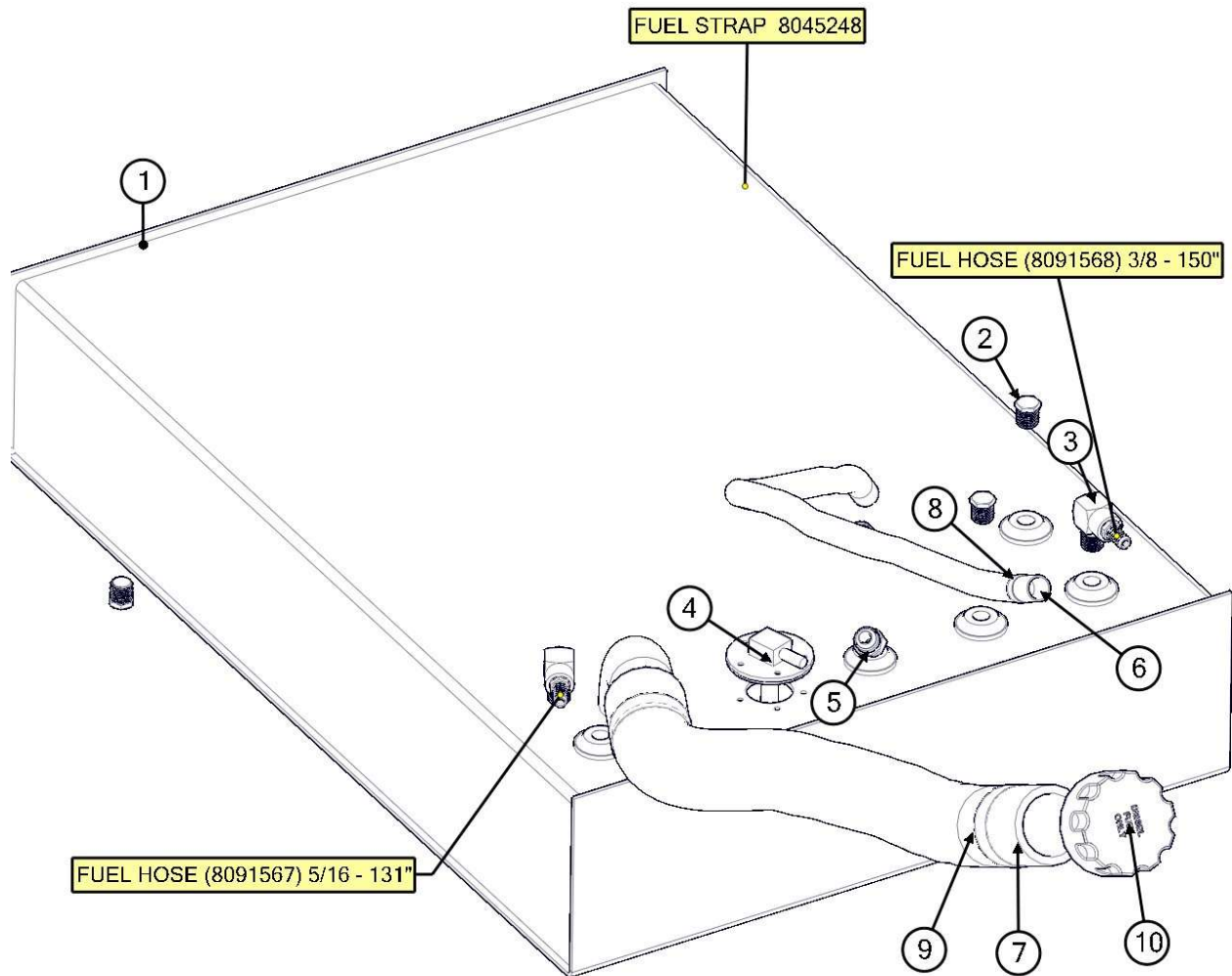

FUEL TANK ASSEMBLY

BOM ID	Qty	Name
1	1	8091301 TANK, FUEL WELDMENT
2	3	T405064 PLUG, 3/8NPT HEX SOCKET
3	2	T401065 ELBOW, 90 6MP-6FP
4	1	8091307 FUEL SENDING UNIT 5"
5	1	T401111 ELBOW, 45 6MP-8MJ
6	1	8091582 HOSE VAC FUEL 5/8 - 31 1/4"LG
7	1	8091096 HOSE VAC AG SUCTION 2 - 20"LG
8	2	U800015 CLAMP, HOSE SIZE 04-5/8
9	2	8044580 CLAMP, HOSE T-BOLT 256
10	1	8091257 FUEL CAP

PAGE LEFT BLANK

HYDRAULIC LAYOUT

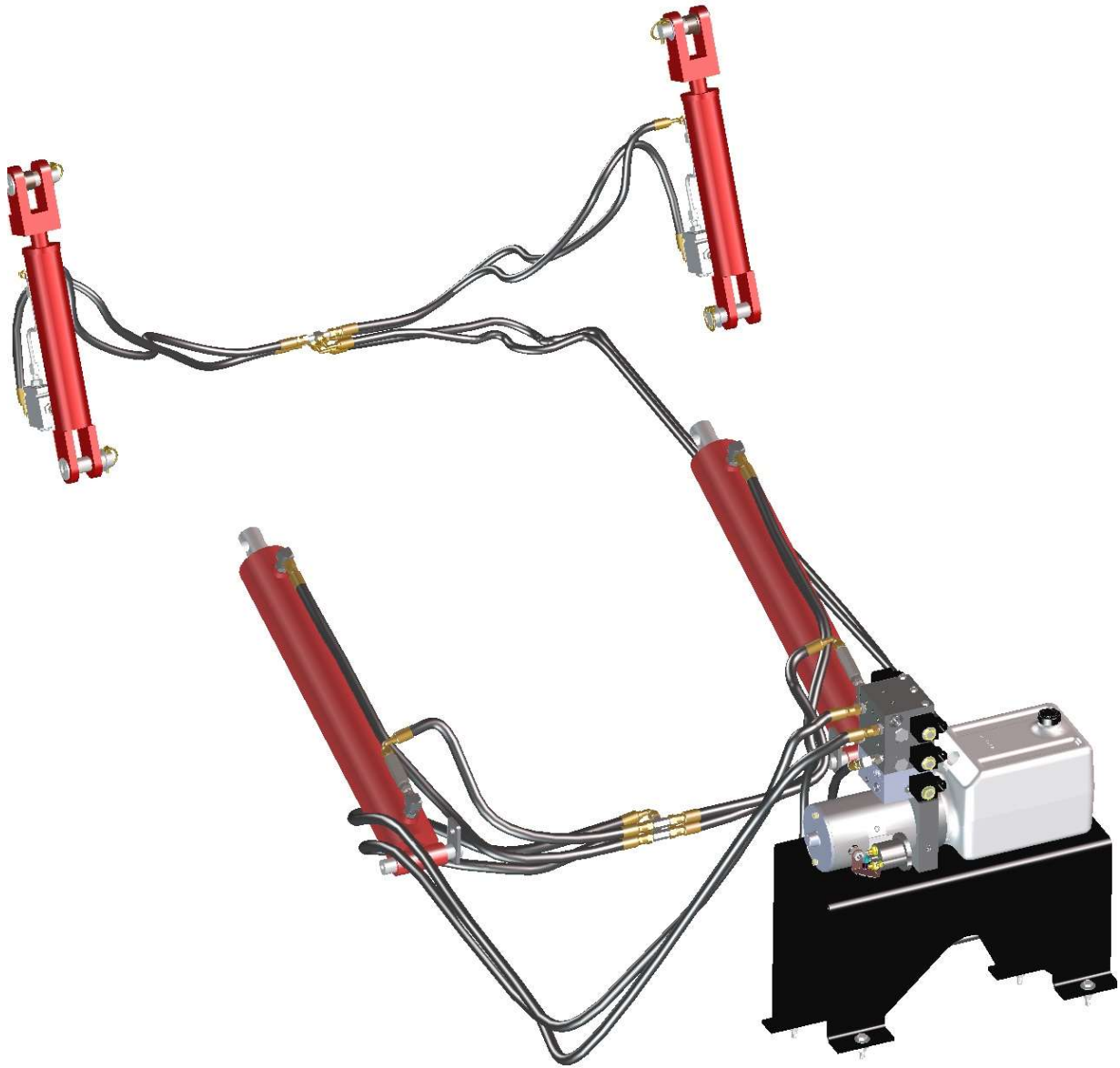

HYDRAULIC PUMP 12V

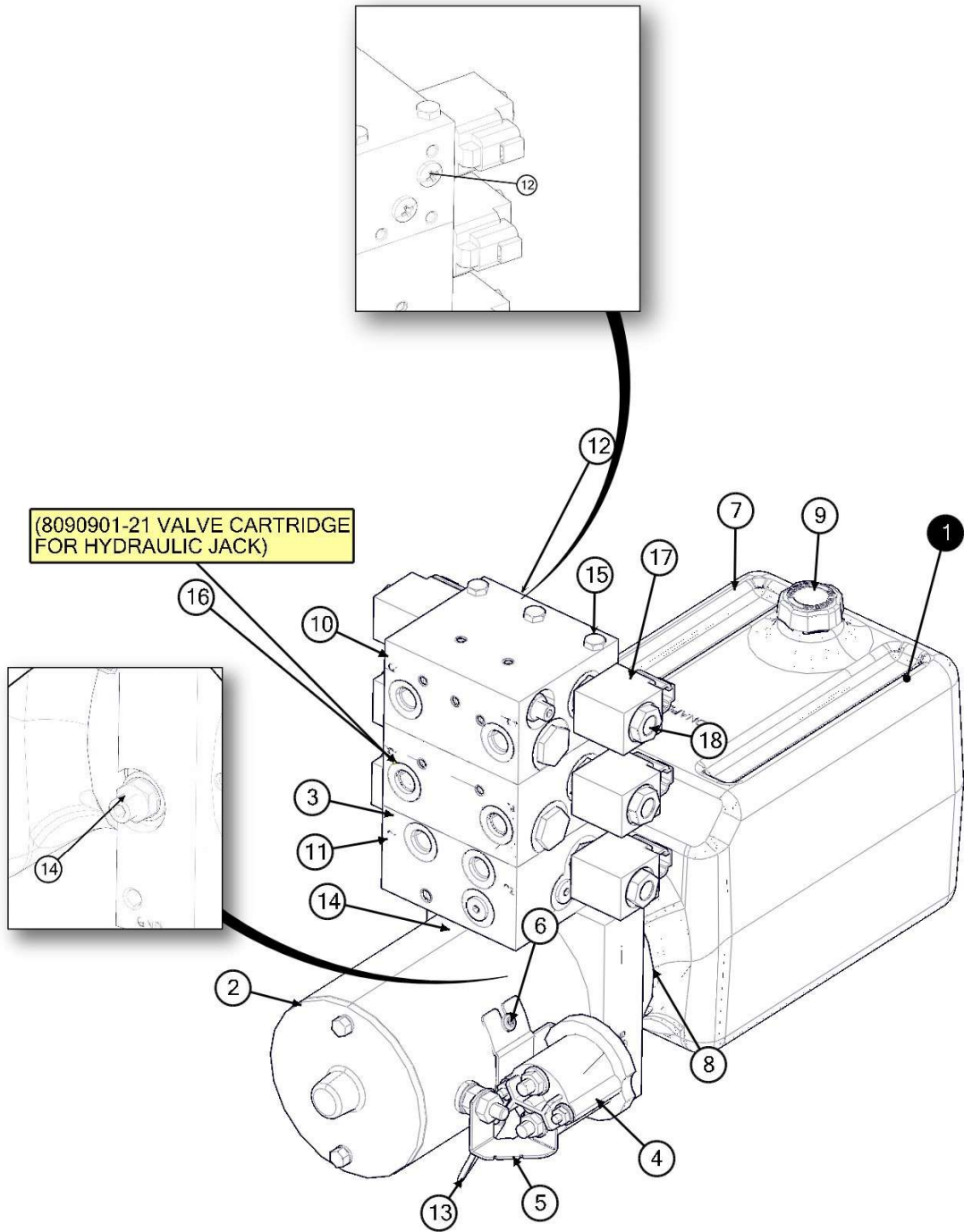

HYDRAULIC PUMP 12V

BOM ID	Qty	Name
1	1	8090901 PUMP, HYD. 12V
2	1	8090901-03 MOTOR, HYDRAULIC PUMP
3	2	8090901-07 O-RING, .63 X .75 X .06-016
4	1	8090901-08 SWITCH, SOLENOID 12VDC
5	1	8090901-09 STRAP, MOTOR SOLENOID CONNECTING
6	2	8090901-10 SCREW,PAN HD TORX. 10-32 X 5/16
7	1	8090901-11 RESEVOIR, PLASTIC 6.7 X 6.7 X 11 H/WT
8	1	8090901-12 CLAMP, HOSE WORM GEAR RSV. M-SER
9	1	8090901-13 PLUG, RESEVOIR
10	1	8090901-14 VALVE, ASSEMBLY 12VDC 4W. RV ON CT
11	1	8090901-15 VALVE, ASSEMBLY ELECTRIC 12VDC
12	2	8090901-18 FITTING, PLUG 1/4-20 SCREW
13	1	8090901-19 WIRE, ASSEMBLY 16AWG HS RING
14	1	8090901-17 VALVE, ASSEMBLY R/V 1001PSI AND UP
15	3	8090901-20 SCREW,HHC 1/4-20 X 7 1/2 G8
16	1	8090901-21 VALVE, ASSEMBLY 12VDC 4W CARTRIDGE
17	1	8090901-22 COIL, 10VDC #8 INT 2 PIN HI WT
18	1	8090901-23 CARTRIDGE, 3W/2P #8 3000PSI

HYDRAULIC PUMP ASSEMBLY

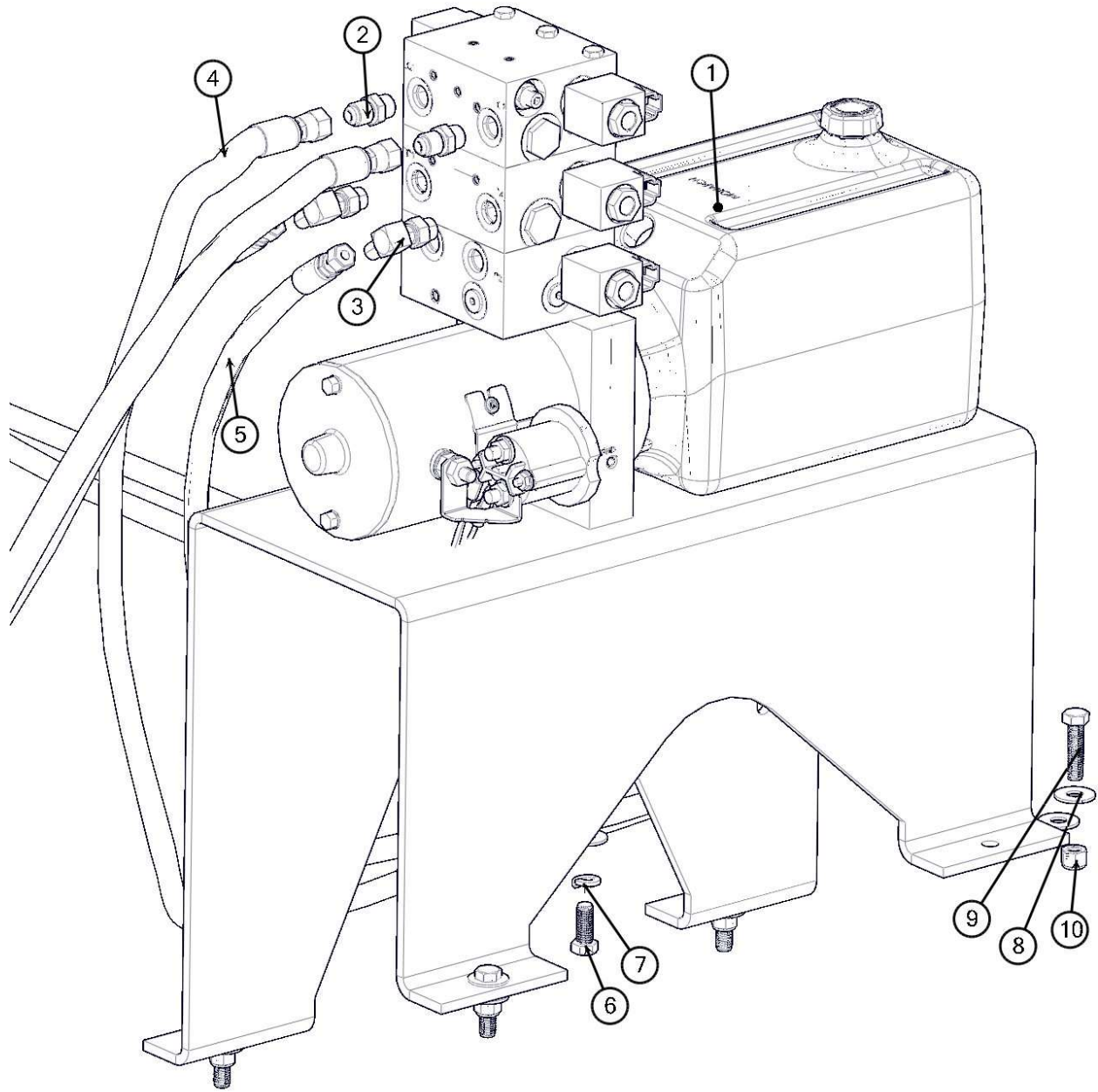

HYDRAULIC PUMP ASSEMBLY

BOM ID	Qty	Name
1	1	8090901 PUMP, HYD. 12V
2	2	T400037 UNION 6MB_6MJ
3	2	T401660 ELBOW 90 6MB_4MJ
4	2	8091032 HOSE ASSY VAC 6-69 ST-90
5	2	8046492 HOSE ASSY VAC 4-125 ST-90
6	2	U000420 SCREW,HC .375-16 X 1.00 ZP G5
7	2	U210060 WASHER, LOCK .375 ZP
8	10	U200060 WASHER, FLAT .375 ZP
9	4	U000460 SCREW, HC .375-16X1.50 ZP G5
10	4	U120110 NUT,LOCK .375-16 NY ZP

HYD. CYLINDER TANK RAISE/LOWER ASSEMBLY

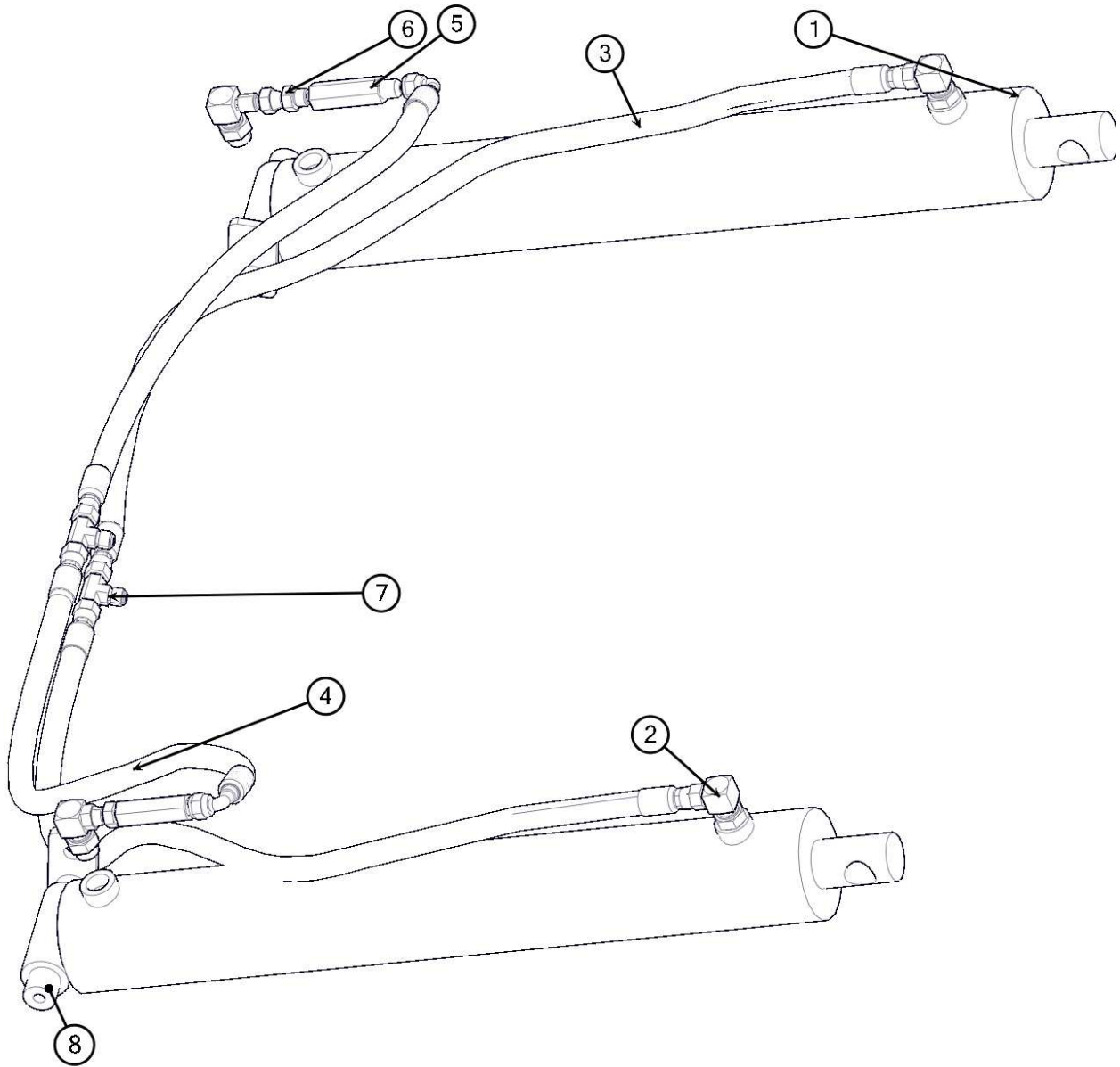

HYD. CYLINDER TANK RAISE/LOWER ASSEMBLY

BOM ID	Qty	Name
1	2	8030359 CYLINDER, HYD. TANK
2	4	T401270 ELBOW 90 8MB_6MJ
3	2	8091033 HOSE ASSY VAC 6-33 ST-ST (TEE TO TANK CYL.)
4	2	8091091 HOSE ASSY VAC 6-13 ST-90 (TEE TO TANK CYL.)
5	2	8048286 VALVE, CHECK VELOCITY (6GPM)
6	2	T400036 UNION 6MB_6FJ
7	2	T402154 TEE 6MJ_6MJ_6MJ
8	2	8091048 PIN, CYLINDER FLANGED 1" X 5 1/2"LG

* NOT SHOWN

2	8091118	PLATE,CYLINDER PIN RETAINER
2	U000399	SCREW,HC .375-16 X .625
2	U200150	WASHER,FLAT .625 ZP
2	U210140	WASHER,LOCK .625 ZP

HYD. DOOR CYLINDER ASSEMBLY

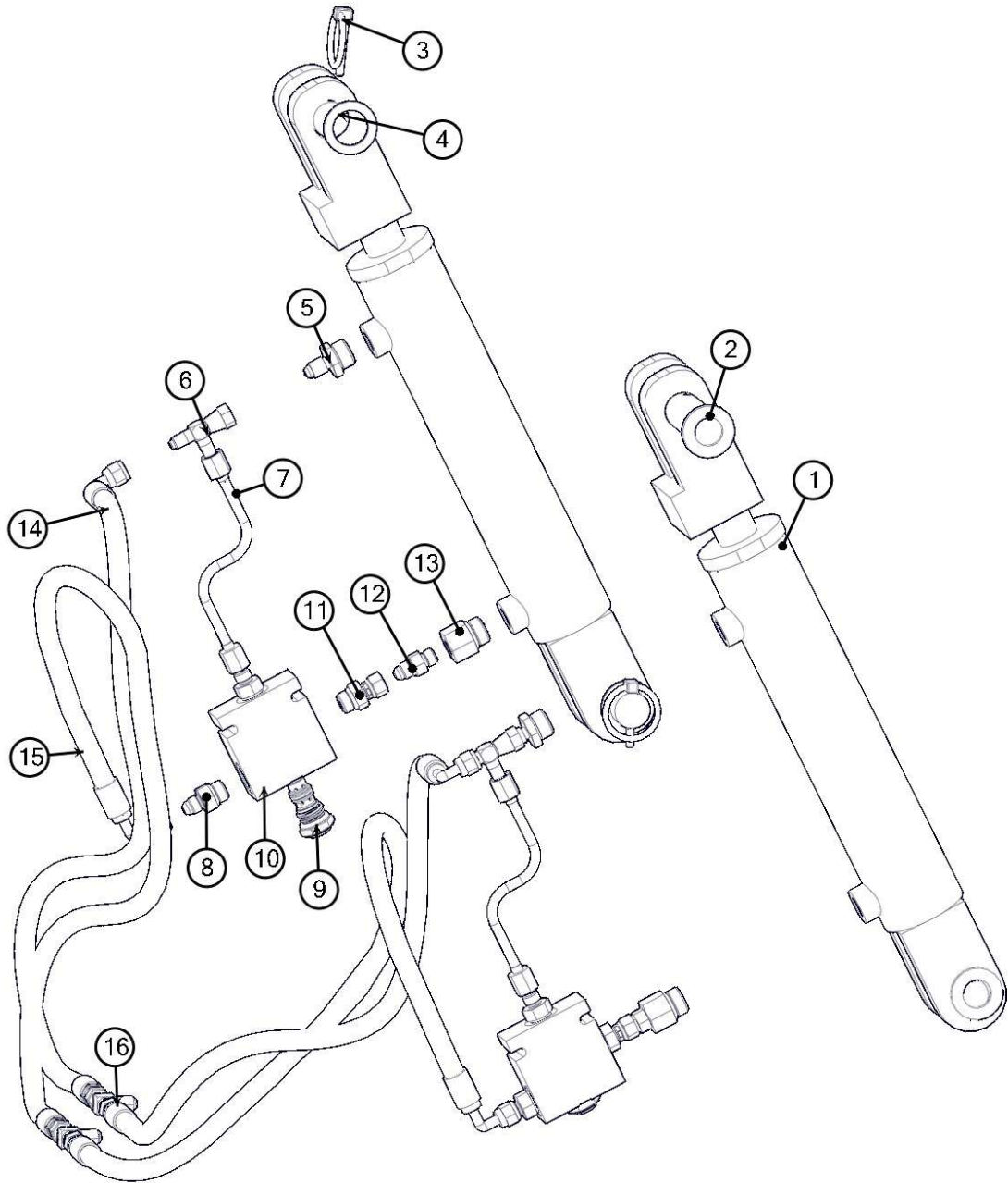

HYD. DOOR CYLINDER ASSEMBLY

BOM ID	Qty	Name
1	2	8041327 CYLINDER, HYDRAULIC DOOR
2	4	8042489 CYLINDER PIN
3	4	U340050 PIN, LINCH 3/16 X 1 9/16
4	4	U200170 WASHER, FLAT 1"
5	2	T400611 REDUCER, 1/2MB-1/4MJ
6	2	T402010 TEE, 1/4FJ-1/4MJ-1/4MJ
7	2	8091142 PIPE, HYDRAULIC ASSEMBLY
8	4	T400840 REDUCER, 3/8MB-1/4MJ
9	2	8091020 VALVE, CHECK PILOT OPERATED
10	2	8091021 CARTIRIDGE, PO CHECK HOUSING
11	2	T400830 REDUCER, 3/8MB-1/4FJ
12	2	8090251 FITTING, ORIFICE .020
13	2	T400350 REDUCER, 1/2MB-1/4FB
14	2	8044762 HOSE ASSY VAC 4-46 1/2 ST-90
15	2	8047714 HOSE ASSY VAC 4-38 ST-90
16	2	T402035 TEE, 4MJ-4MJ-4MJ

HYDRAULIC ARM ASSEMBLY

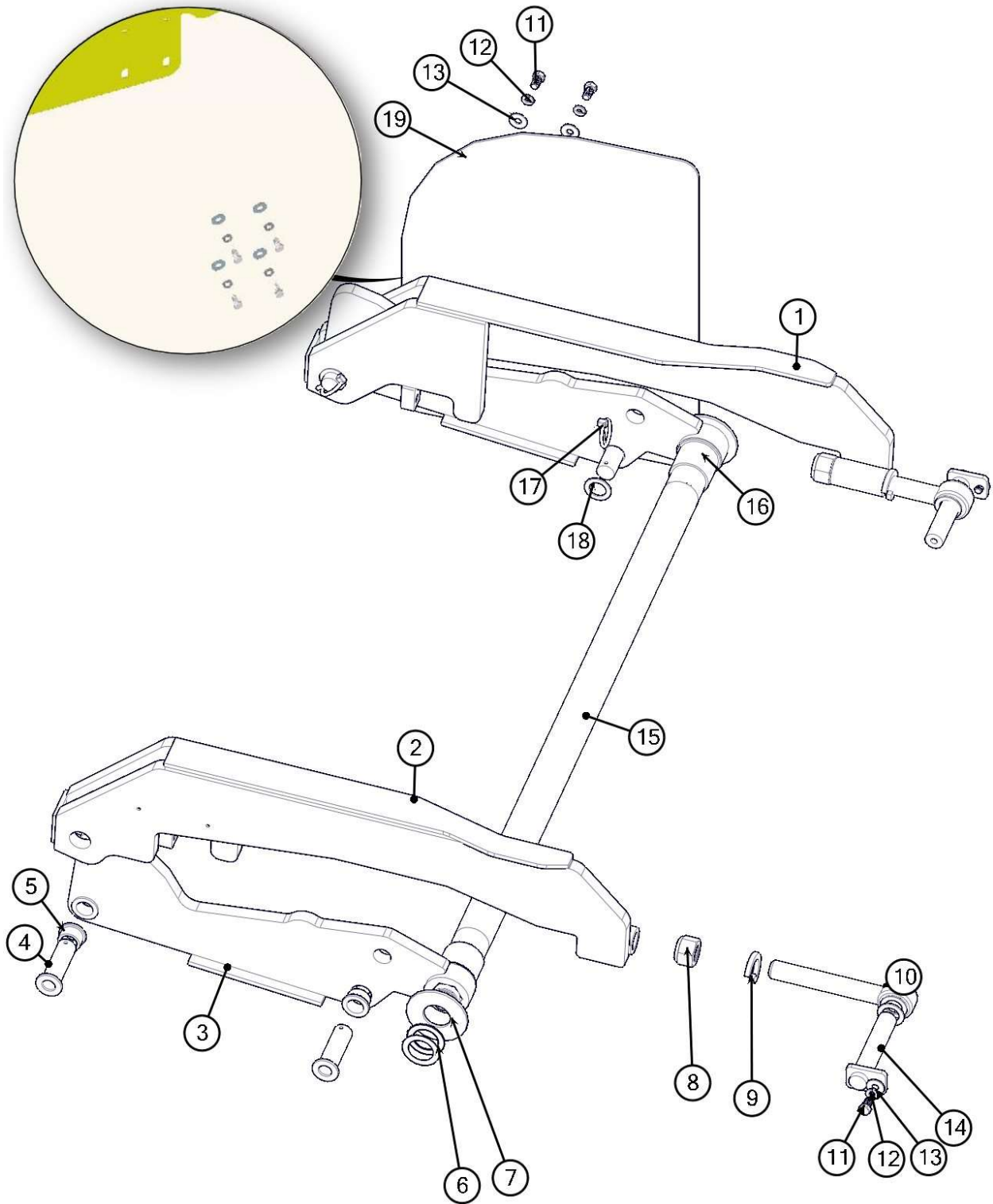

HYDRAULIC ARM ASSEMBLY

BOM ID	Qty	Name
1	1	8049763 LINKAGE, HYD. DOOR LONG (SS)
2	1	8049765 LINKAGE, HYD. DOOR LONG (CS)
3	2	8049766 LINKAGE, HYD. DOOR SHORT
4	4	8042489 PIN, CYLINDER
5	8	8041883 BUSHING, BRONZE 1 1/4 X 1" X .63 FL
6	16	U420225 SHIM, ARBOR 1 1/2 X 2 1/8 X .010
7	2	U200176 WASHER, FLAT 1 1/2
8	2	U120060 NUT, LOCK 1-8 NY ZP G2
9	2	U210200 WASHER, LOCK 1" ZP
10	2	8043131 ROD END 1"-8 X 7 1/2"
11	6	U000400 SCREW,HC 3/8-16 X .750 ZP G5
12	6	U210060 WASHER, LOCK 3/8 ZP
13	6	U200060 WASHER, FLAT 3/8 ZP
14	2	8043844 PIN, CYLINDER FLANGE 1 X 5 1/2"
15	1	8049718 LINKAGE CROSS TUBE
16	2	8041602 BUSHING, BRONZE FLANGED 2"
17	4	U340050 PIN, LINCH 3/16 X 1 9/16
18	18	U200170 WASHER, FLAT 1"
19	1	8049762 GUARD, HYDRAULIC ARM

SPOIL TANK ASSEMBLY

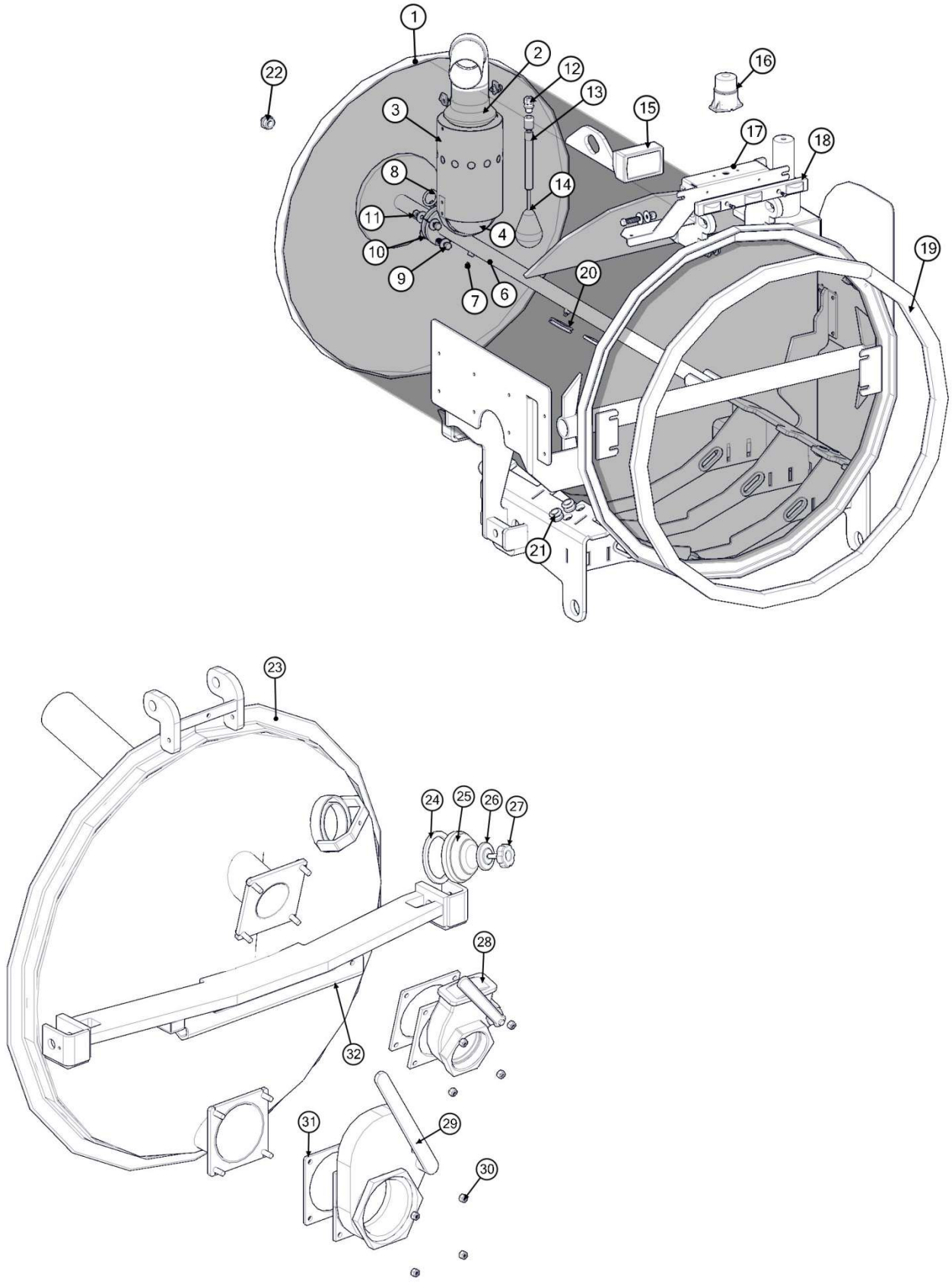

SPOIL TANK ASSEMBLY

BOM ID	Qty	Name
1	1	8090812 TANK, 500HD
2	1	8043571 SEAT, RUBBER 4" for FLOAT BALL
3	1	8043700 WELDMENT, FLOAT SHUTOFF
4	1	8043570 BALL, STAINLESS FLOAT 6"
6	1	8041566 ROD, TANK CLEANOUT
7	3	8030369 NOZZLE, TANK CLEANOUT
8	1	8030446 #328 o'ring
9	4	U000800 SCREW,HC 1/2-13 X 2.00 ZP G5
10	8	U200100 WASHER, FLAT 1/2 ZP
11	4	U160018 NUT, LOCK 1/2-13 NY ZP
12	1	X000113 RELIEF, STRAIN 1/2NPT
13	1	8040769 TUBE, 8" TANK FULL SWITCH
14	1	8030531 SWITCH, FLUID LEVEL
15	1	8043138 WORK LIGHT
16	1	8043139 STROBE LIGHT
17	1	8047095 BRACKET, WORK/STROBE LIGHT
18	1	8041509 LIGHT, CLEARANCE 3 BAR
19	1	8041765 SEAL, DOOR
20	10	8042812 GROMMET, 2"ID X 3"OD X 1/4"WOG
21	4	8041686 GROMMET, 1"ID X 1 1/2"OD X 1/2"WOG
22	1	T400310 REDUCER, 16MB-6MJ
23	1	8049753 DOOR, HYDRAULIC 500HD
24	1	8032007 GASKET, 4" FLAT ALUM COUPLER
25	1	8031048 SIGHTGLASS, 5" GLASS ONLY
26	1	8031047 PLATE, SIGHTGLASS
27	1	8031046 HANDWHEEL, SIGHTGLASS
28	1	8046215 VALVE, 4" GATE BRASS LEVER FLANGED
29	1	8046214 KIT, VALVE 6" BRASS LEVER TYPE
30	8	U120132 NUT, LOCK 7/16-14 NY
31	2	8046191 GASKET, DOOR INPUT/OUTPUT
32	1	8041212 TANK SAFETY BRACE

FILTRATION ASSEMBLY

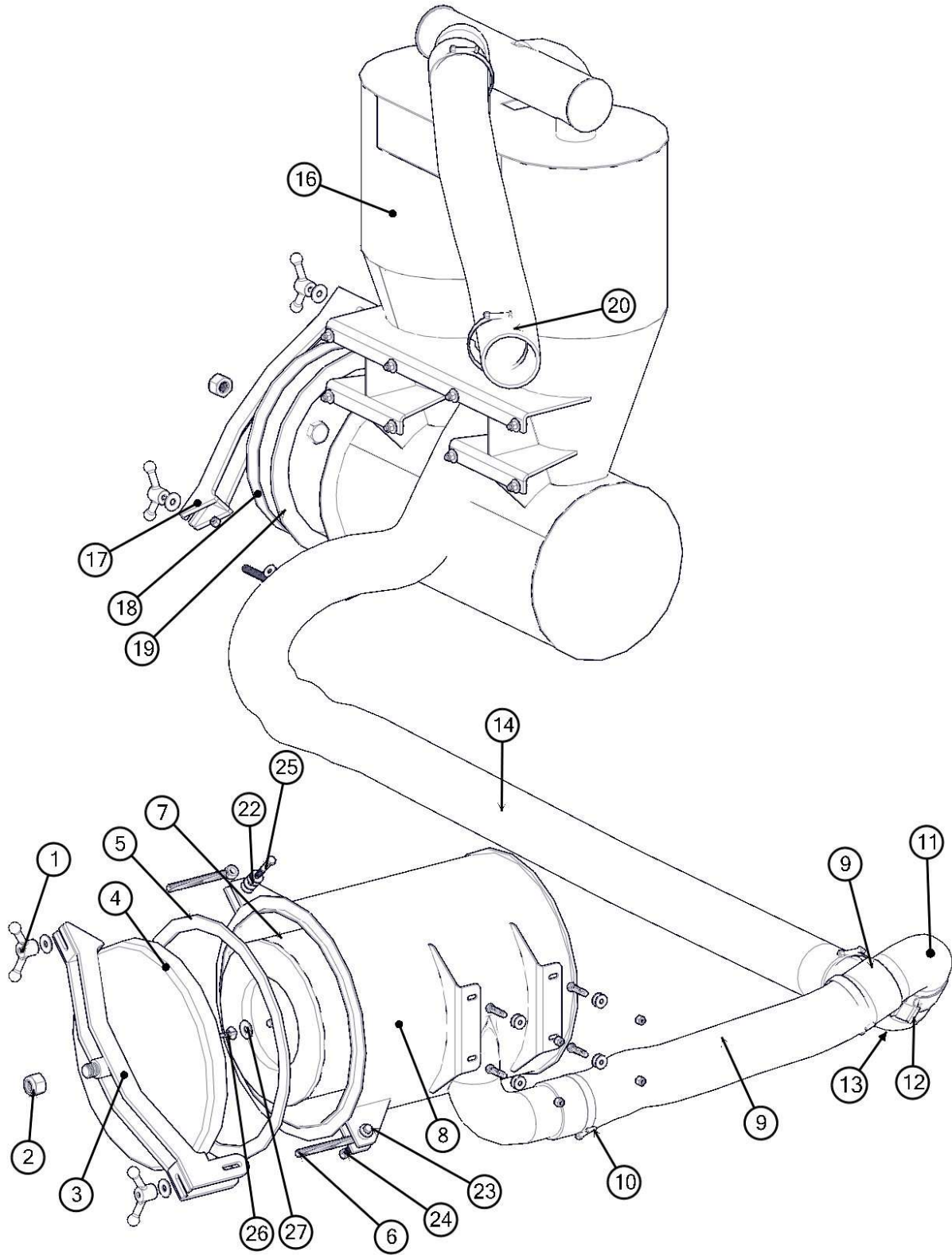

FILTRATION ASSEMBLY

BOM ID	Qty	Name
1	4	8041594 HANDLE, WING 1/2-13
2	2	U120060 NUT, LOCK 1-8 NY ZP G2
3	1	8041554 LATCH, AIR-FILTER DOME
4	1	8041387 DOME, AIR-FILTER REV. FLOW
5	1	8041613 GASKET, AIR-FILTER REV. FLOW
6	4	8041593 BOLT, EYE 1/2-13 X 6.00
7	1	8031293 FILTER, AIR WASHABLE 1025 CFM
8	1	8049538 AIR-FILTER HOUSING 1025 CFM
9	1	8091043 HOSE VAC AG SUCTION 4-47"
10	6	8042606 CLAMP, T-BOLT 4" HOSE
11	1	8040929 EXHAUST ELBOW 4" ID-OD
12	1	8030400 CLAMP, BAND 4" EXHAUST
13	1	8091341 EXHAUST ELBOW 4" OD-OD
14	1	8044489 HOSE VAC AG SUCTION 4-75"
16	1	8046458 CYCLONE HOUSING 1025 RF
17	1	8041552 LATCH, DOME CYCLONE
18	1	8041402 DOME, CYCLONE REV. FLOW
19	1	8041612 GASKET, CYCLONE REV. FLOW
20	1	8047019 HOSE VAC AG SUCTION 4-45"
22	44	U200060 WASHER, FLAT 3/8 ZP
23	2	U000580 SCREW,HC 3/8-16 X 3.50 ZP G5
24	4	U120110 NUT, LOCK 3/8-16 NY ZP
25	2	U000520 SCREW,HC 3/8-16 X 2.25 ZP G5
26	1	U130080 NUT,WING 1/2-13 ZP G2
27	1	U200100 WASHER FLAT 1/2 ZP

POWERPACK LAYOUT

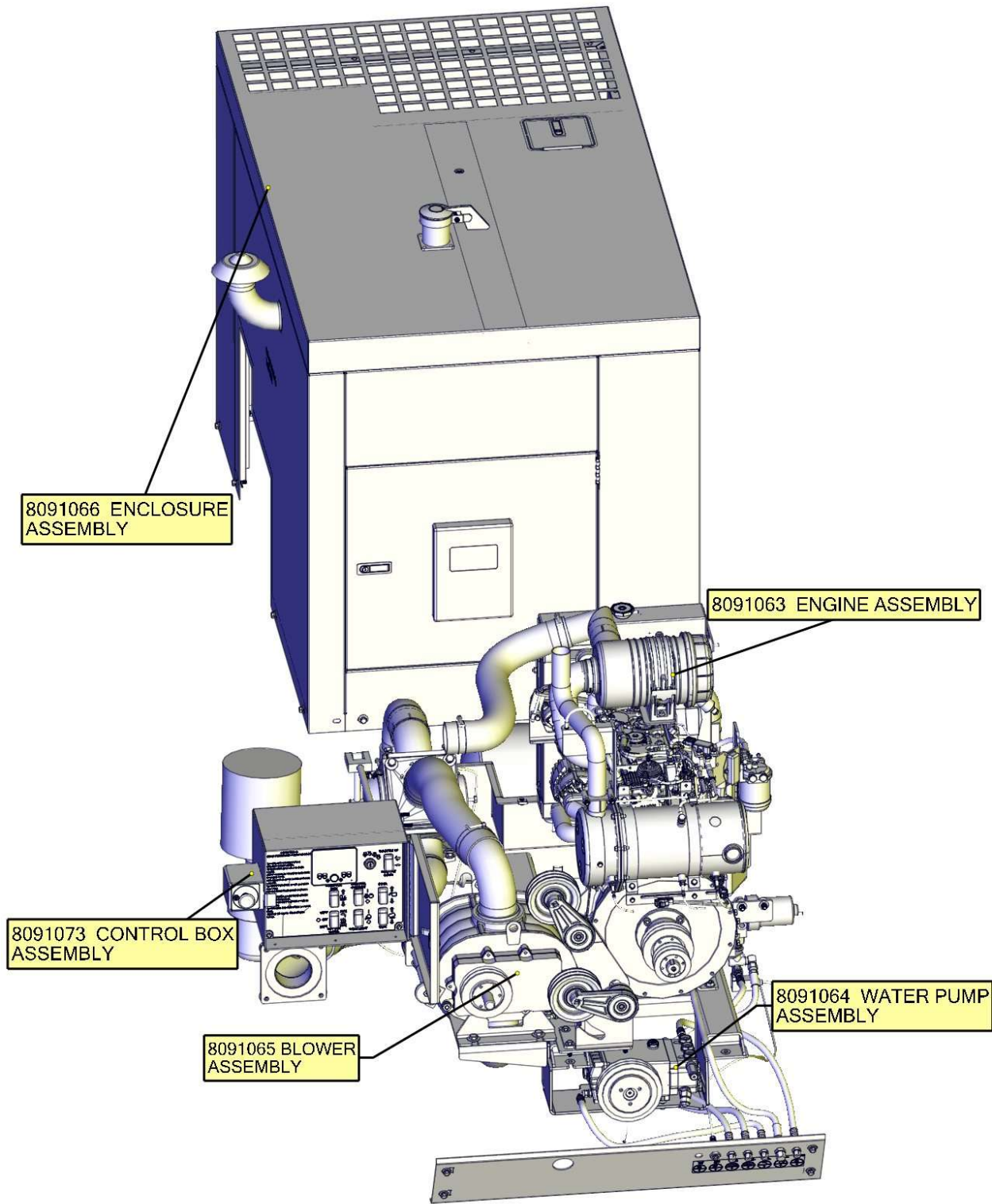

PAGE LEFT BLANK

CONTROL BOX ASSEMBLY

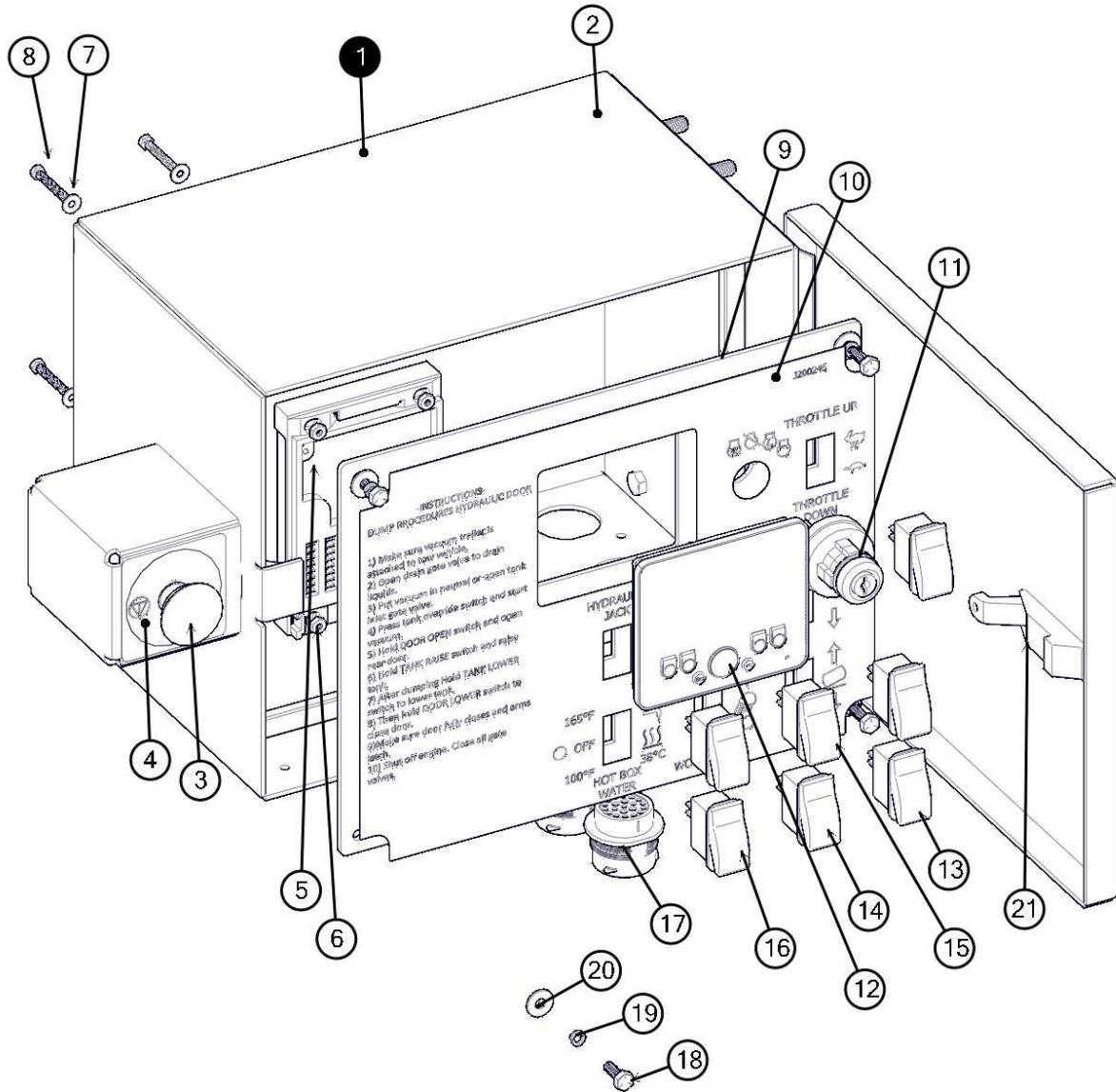

CONTROL BOX ASSEMBLY

BOM ID	Qty	Name
1	1	8049527 CONTROL BOX ASSEMBLY (COMPLETE)
2	1	8049529 CONTROL BOX
3	1	X000280 EMERGENCY STOP
4	1	J200251 DECAL, E-STOP
5	1	8049526 CONTROLLER
6	4	U100010 NUT, HEX M_S 10_24
7	4	U200001 WASHER, FLAT #10
8	4	U002000 SCREW,HC 10-24 X 1.50 MS ZP
9	1	8049528 FACE PLATE, CONTROL BOX
10	1	J200245 DECAL, CONTROL PANEL
11	1	8030458 SWITCH, IGNITION
12	1	8049525 CONTROL DISPLAY BC XT
13	4	X000450 SWITCH, ROCKER MOMENTARY ON-OFF-ON
14	1	X000452 SWITCH, ROCKER ON/OFF
15	1	X000451 SWITCH, ROCKER MOMENTARY OFF/ON
16	1	X000453 SWITCH, ROCKER ON-OFF-ON
17	2	X500004 RECEPTACLE, DEUTSCH 21PIN
18	4	U000040 SCREW,HC 1/4-20 X .750 ZP G5
19	4	U210020 WASHER, LOCK 1/4 ZP
20	4	U200020 WASHER, FLAT 1/4 ZP
21	1	8048788 LATCH

ENCLOSURE ASSEMBLY

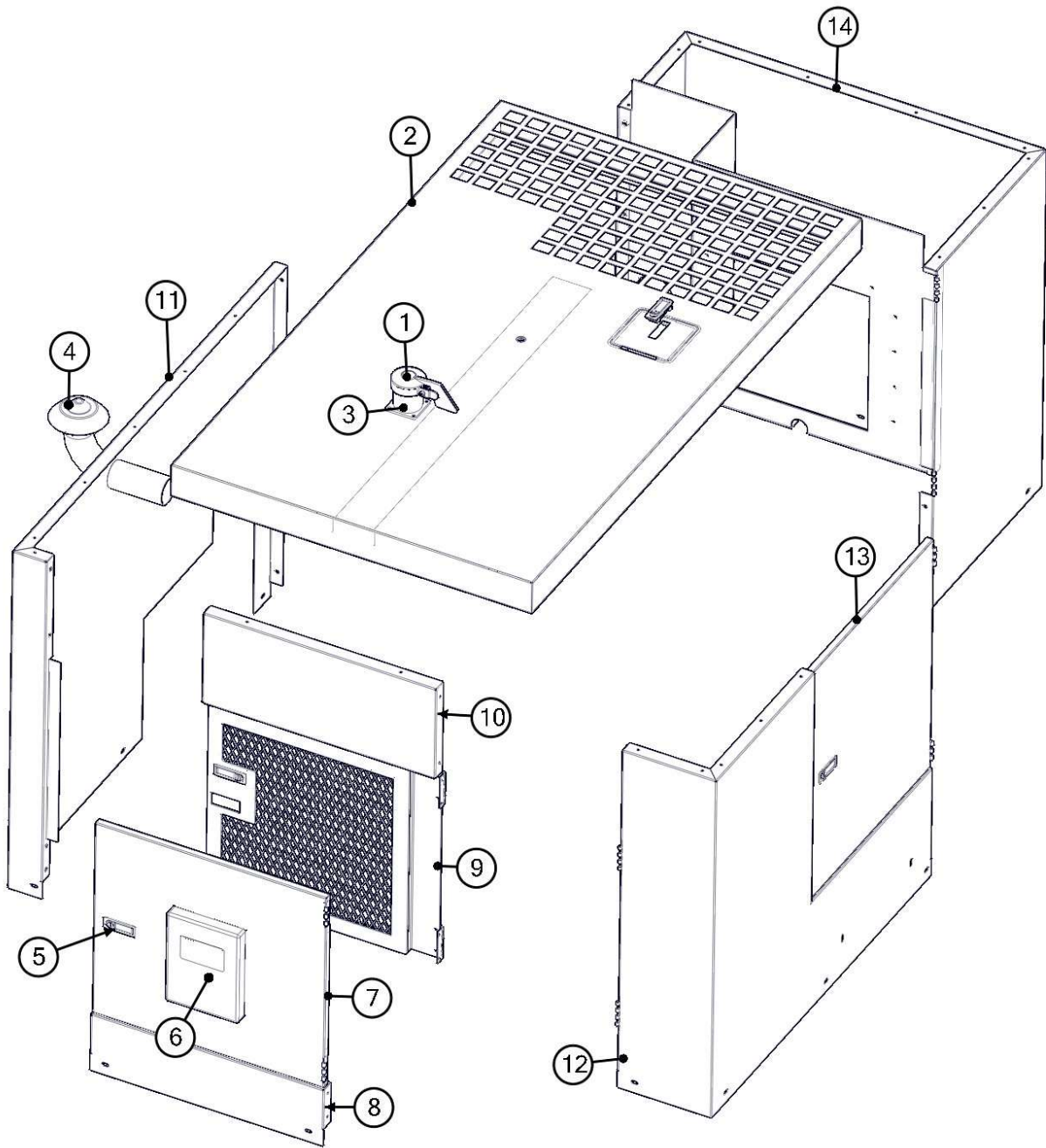

ENCLOSURE ASSEMBLY

BOM ID	Qty	Name
1	1	8044537 CAP, RAIN 3" SILENT
2	1	8090839 ENCLOSURE, TOP PANEL
3	1	8091136 EXHAUST EXTENTION WELDMENT
4	1	8091506-01 CAP, AIR INTAKE
5	4	8048788 LATCH
6	1	8030689 BOX, PLASTIC for SAFETY MANUAL
7	1	8090857 ENCLOSURE, DOOR CURB SIDE
8	1	8090849 ENCLOSURE, CURB SIDE BOTTOM PANEL
9	1	8091369 BELT GUARD ASSEMBLY
10	1	8090850 ENCLOSURE, CURB SIDE TOP
11	1	8090842 ENCLOSURE, REAR CURB SIDE PANEL
12	1	8090846 ENCLOSURE, FRONT CURB SIDE PANEL
13	1	8090855 ENCLOSURE, FRONT DOOR
14	1	8090843 ENCLOSURE, PLENUM PANEL

ENGINE ASSEMBLY

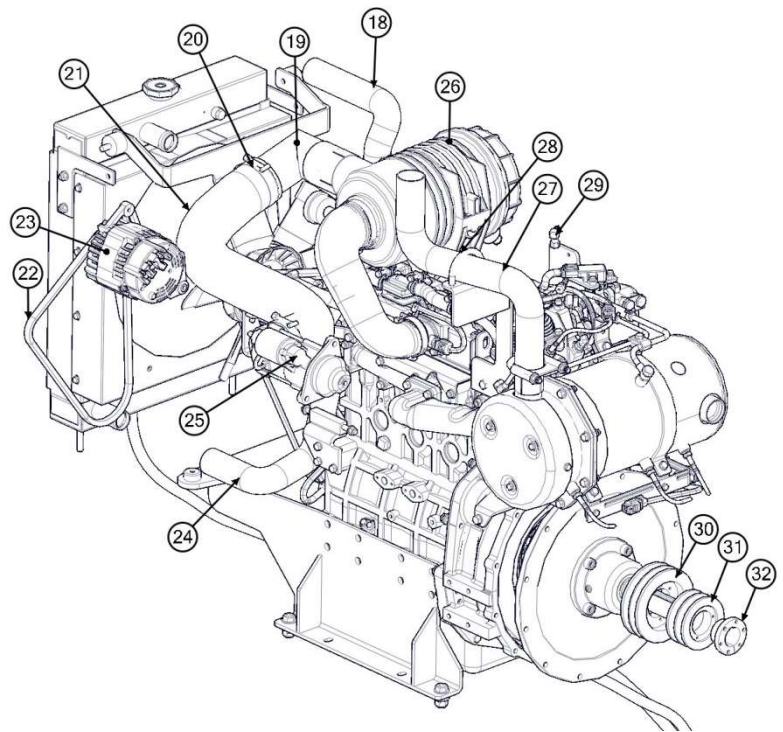
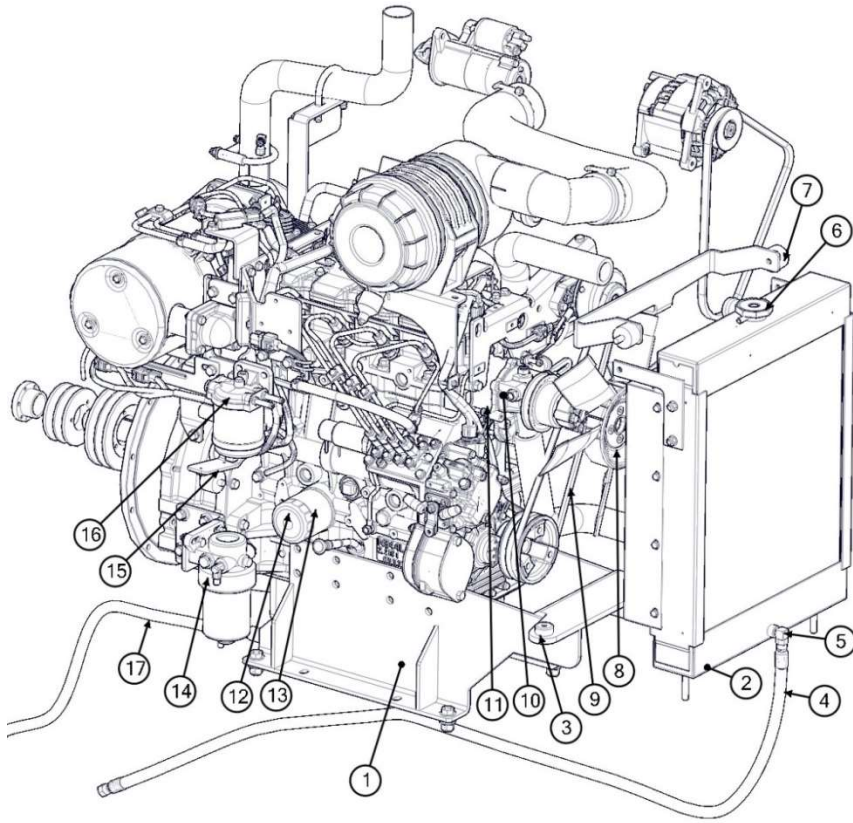

ENGINE ASSEMBLY

BOM ID	Qty	Name
1	1	8049413 ENGINE, PERKINS 49HP
2	1	8091509 RADIATOR
3	2	8091510 MOUNT, RADIATOR (BOTTOM)
4	1	8091102 HOSE, DRAIN RADIATOR 8-25 ST-ST
5	1	T401101 ELBOW 90 6MJ_4MP
6	1	8091512 CAP, RADIATOR
7	2	8091511 MOUNT, RUBBER 3/8 X 1" M/M
8	1	8091515 FAN
9	1	8091508 BELT, AIR PUMP
10	1	8091517 PUMP, WATER
11	1	8091818 GASKET, WATER PUMP
12	1	8091505 FILTER, OIL
13	1	8091523 GASKET, OIL FILTER
14	1	8047266-01 FILTER, FUEL-WATER SEPARATOR
15	1	8092475 FILTER, FUEL
16	1	8091522 PUMP, FUEL ELECTRIC
17	1	8091102 HOSE ASSY VAC 6-56 ST-ST (RADIATOR DRAIN)
18	1	8091513 HOSE, RADIATOR (UPPER)
19	1	8045637 ELBOW EXHAUST 90 3" ID-OD TIGHT
20	2	8042605 CLAMP, HOSE T-BOLT 350
21	1	8091532 HOSE,AIR INTAKE 3 X 36"LG
22	1	8091507 BELT, FAN ALTERNATOR
23	1	8091516 ALTERNATOR
24	1	8091514 HOSE, RADIATOR (BOTTOM)
25	1	8091519 STARTER
26	1	8091506 ELEMENT, AIR FILTER
27	1	8091130 EXHAUST TUBE
28	2	U800120 CLAMP,U-BOLT 2IN EXHAUST
29	1	T401225 ELBOW 90 4FJ_4MJ
30	1	8090884 SHEAVE, 5.50"DIA QD2/5V5.50
31	1	8090882 SHEAVE, 3.95"DIA QD2A3.2
32	1	8049387 BUSHING, SH 1 1/2

**BLOWER LAYOUT
W/ 6" 4-WAY VALVE**

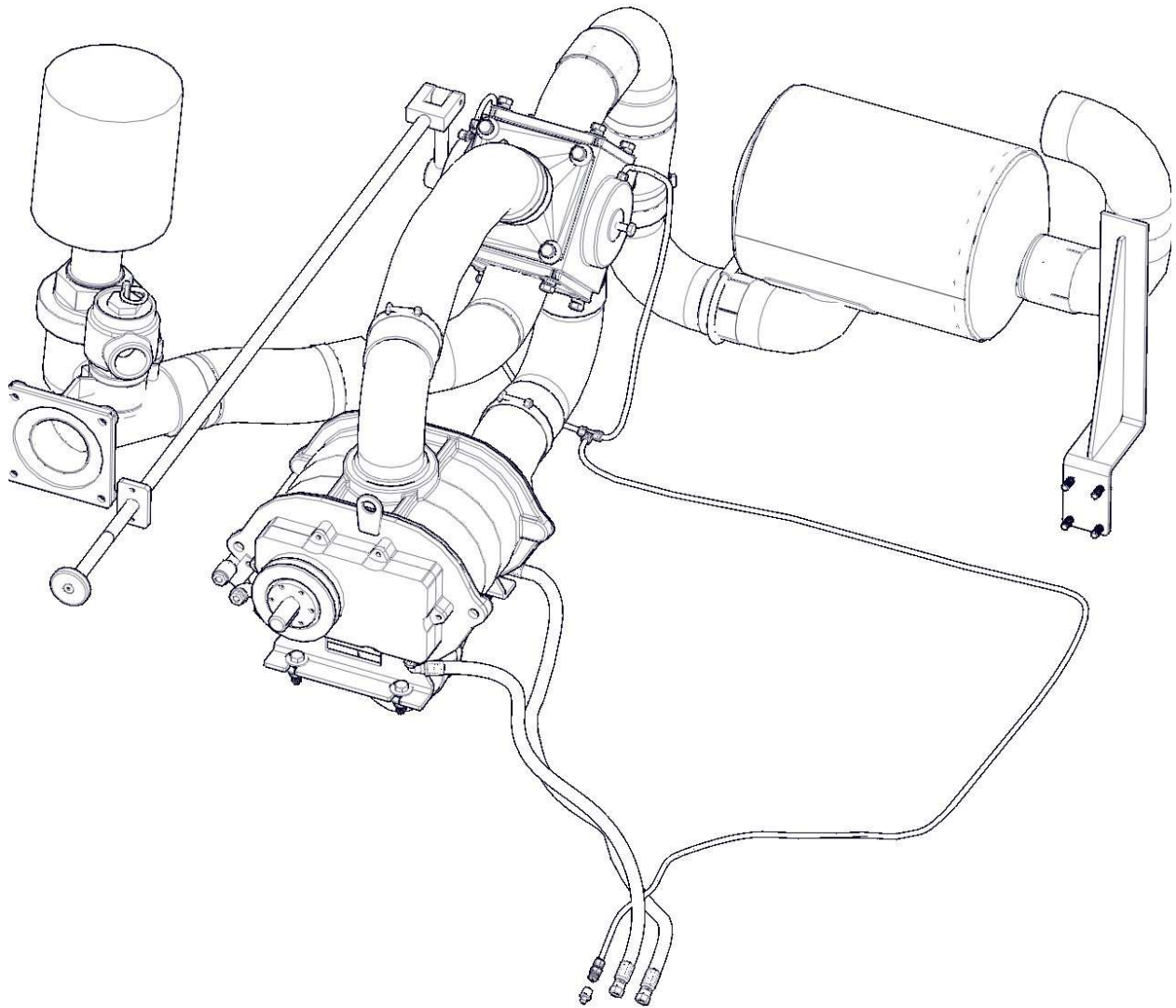

SERIAL NUMBER - VX5062014615 TO VX5092914811

PAGE LEFT BLANK

BLOWER ASSEMBLY PT1

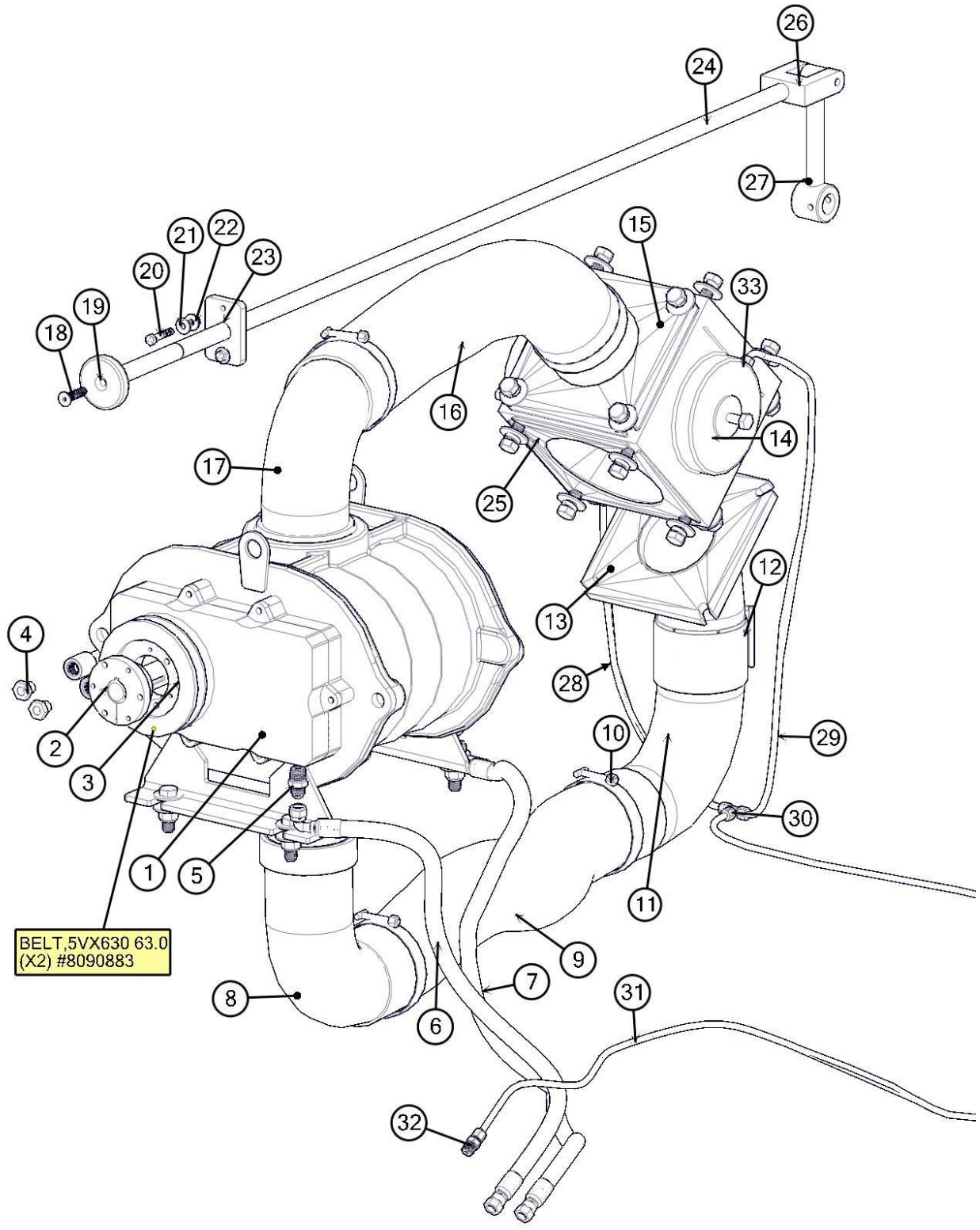

BLOWER ASSEMBLY PT1

BOM ID	Qty	Name
1	1	8040001 PUMP, VACUUM 1025
2	1	8090886 BUSHING, 1 1/8"DIA SDS 1 1/8
3	1	8090884 SHEAVE, 5.50"DIA QD2/5 V5.50
4	2	8048571 SIGHT GLASS
5	2	T400028 UNION 6MP_6MJ
6	1	8091100 HOSE ASSY VAC 6-35 ST-90 (BLOWER DRAIN FRONT)
7	1	8091101 HOSE ASSY VAC 6-40 ST-90 (BLOWER DRAIN REAR)
8	1	8049404 ELBOW, EXHAUST 4"OD 45
9	1	802929-026.00 HOSE AG HOT AIR 4-26"
10	4	8042606 CLAMP, T-BOLT 4" HOSE
11	1	8040929 ELBOW, EXHAUST 4" 90
12	1	8030400 CLAMP, BAND 4" EXHAUST
13	1	8049403 EXHAUST FLANGE WELDMENT
14	1	8045829 VALVE, 4WAY 6" W/O FLANGE
15	1	8046984 EXHAUST FLANGE 4-WAY 6 X 4 TUBE
16	1	8092929-016.00 HOSE AG HOT AIR 4-16"
17	1	8090708 TUBE, BLOWER INPUT WELDMENT
18	1	U030065 SCREW,SFH 5/16-18 X 1.50 ZP G5
19	1	8049593 HANDLE, GRIP VALVE PUSH ROD
20	2	U000100 SCREW,HC 1/4-20 X 1.50 ZP G5
21	4	U200020 WASHER FLAT 1/4 ZP
22	2	U100020 NUT,HEX 1/4-20
23	1	8049591 BUSHING, VALVE HANDLE PUSH ROD
24	1	8049595 ROD, 4-WAY VALVE 6"
25	4	8046995 GASKET, FLANGE 4-WAY 6"
26	1	8049592 VALVE, HANDLE PUSH ROD END
27	1	8049588 VALVE, HANDLE
28	1	8091602 TUBE, NYLON 1/4 X 37"LG
29	1	8091601 TUBE, NYLON 1/4 X 24"LG
30	1	T402009 TEE 1/4TB X 1/4TB X 1/4TB
31	1	8091603 TUBE, NYLON 1/4 X 90 1/2"LG
32	1	T320308 FITTING, COMP 1/4T X 1/4M
33	2	T320309 FITTING, COMP 1/4T X 1/8M

8040001 - PARTS

8040001-7	GASKET, GEAR BOX, DE COVER
8040001-21	PLUG, PIPE
8040001-25	BREATHER (PLUG VENT)
8040001-27	SEAL, LIP BEARING
8040001-33	SEAL LIP-DRIVE
8040001-50	DRIVE END COVER
8040001-53	OIL SIGHT GLASS

BLOWER ASSEMBLY PT2

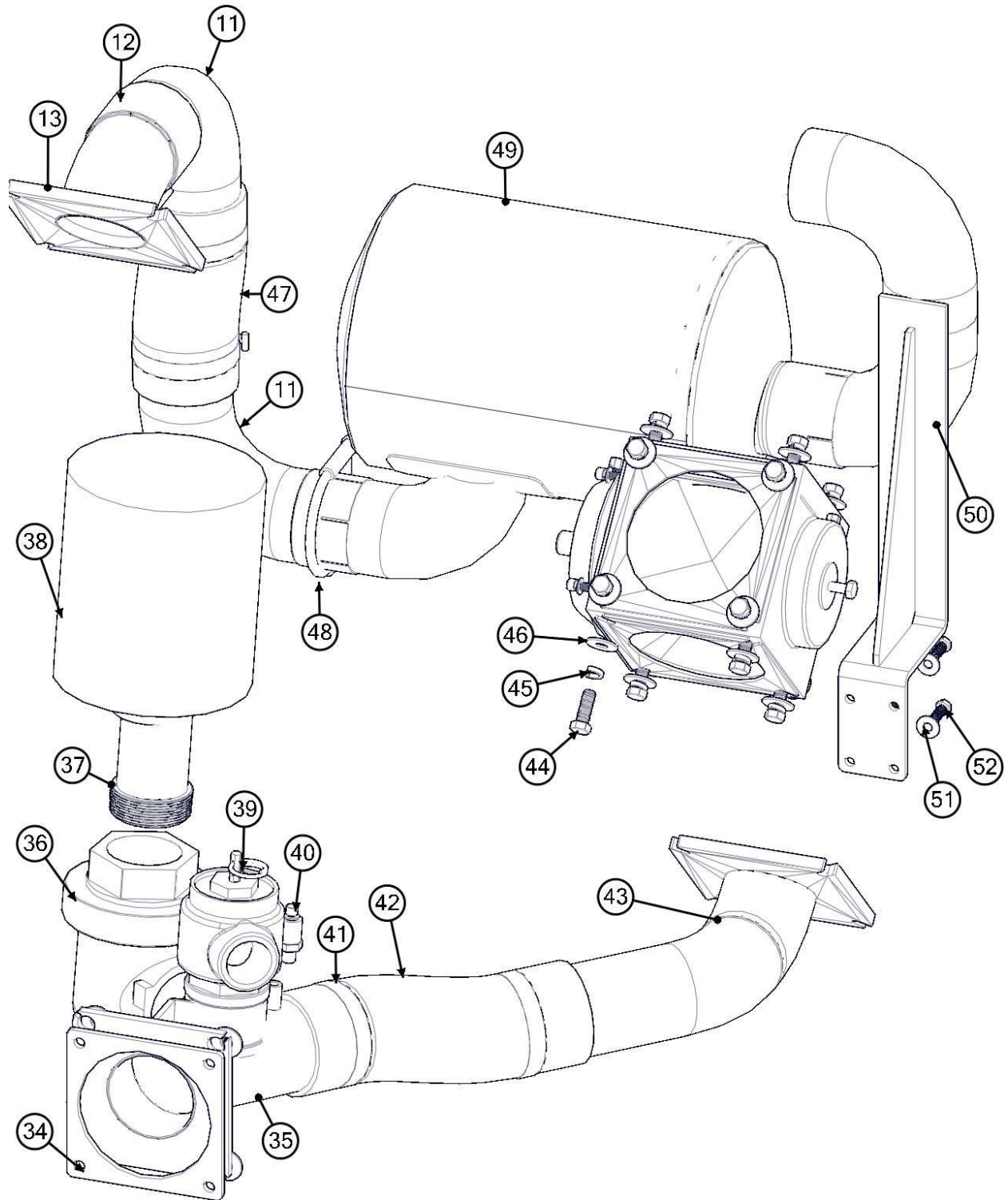

BLOWER ASSEMBLY PT2

BOM ID	Qty	Name
11	2	8040929 ELBOW, EXHAUST 4" 90
12	1	8030400 CLAMP, BAND 4" EXHAUST
13	1	8049403 EXHAUST FLANGE WELDMENT
34	1	8046191 GASKET, HEADER
35	1	8091040 HEADER, AIR FILTER 1025
36	1	8030866 VALVE, 3" AIR RELIEF (SET 15"HG)
37	1	8045238 UNION EXHAUST 3IN OD MNPT
38	1	8043553 FILTER, AIR 3" 245 CFM
39	1	8041035 PRESSURE RELIEF 1025
40	1	X000085 PRESSURE TRANSDUCER
41	4	8042606 CLAMP, T-BOLT 4" HOSE
42	1	8091058 HOSE VAC AG SUCTION 4-14 1/2"
43	1	8090824 EXHAUST ELBOW FLANGED WELDMENT
44	16	U000840 SCREW,HC 1/2-13 X 1.50 ZP G5
45	16	U210100 WASHER, LOCK 1/2 ZP
46	16	U200100 WASHER, FLAT 1/2 ZP
47	1	8090258 HOSE VAC AG SUCTION 4-12"
48	1	8031193 CLAMP U_BOLT 4in EXHAUST
49	1	8090802 SILENCER, 4" COWL
50	1	8090395 SILENCER OUTPUT TUBE WELDMENT
51	4	U200060 WASHER, FLAT 3/8 ZP
52	4	U000440 SCREW,HC 3/8-16 X 1.25 ZP G5

BLOWER LAYOUT

W/4" 4-WAY VALVE

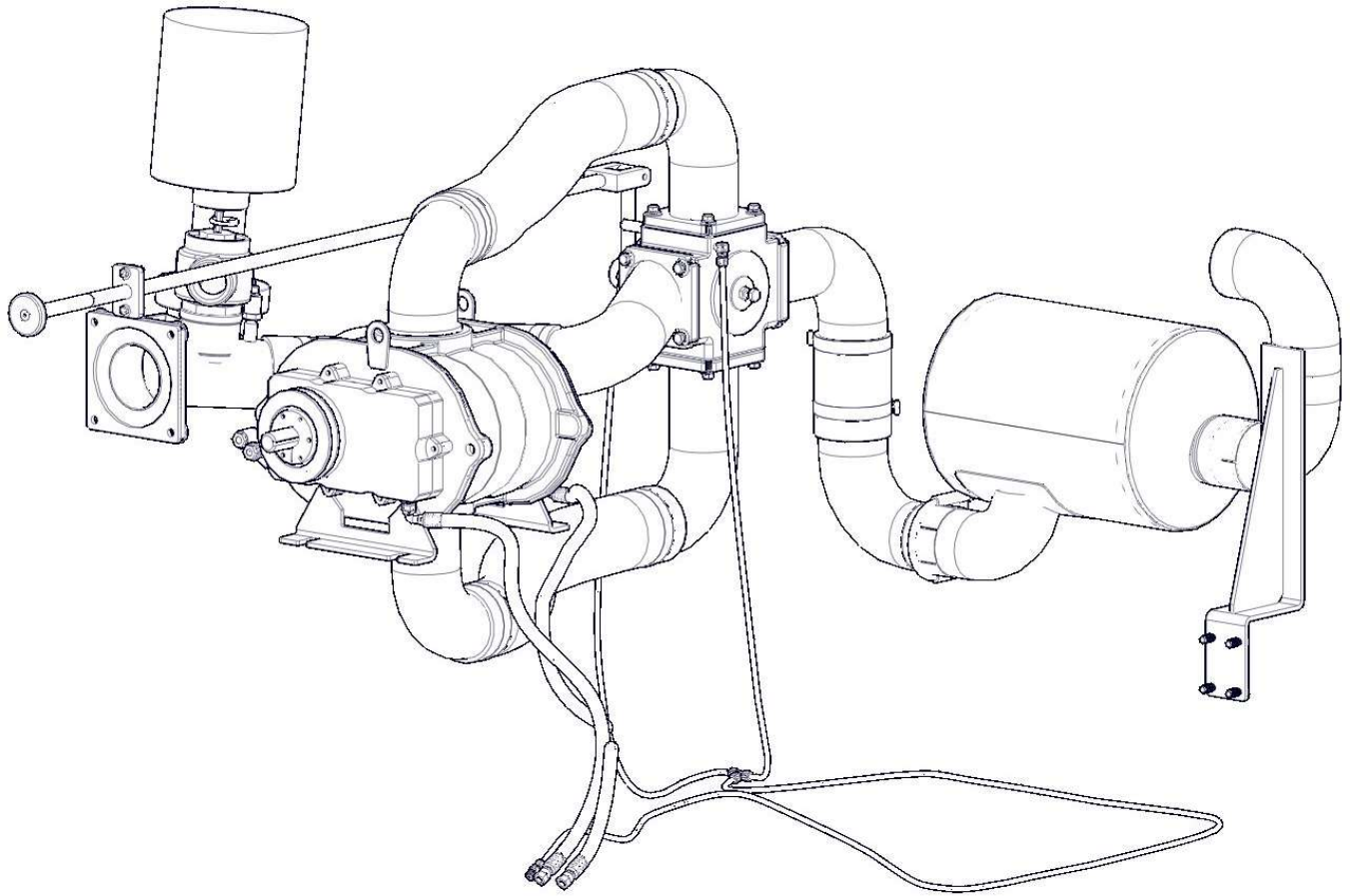

SERIAL NUMBER -
VX5092914812 TO
PRESENT

PAGE LEFT BLANK

BLOWER ASSEMBLY PT1

4" 4-WAY VALVE

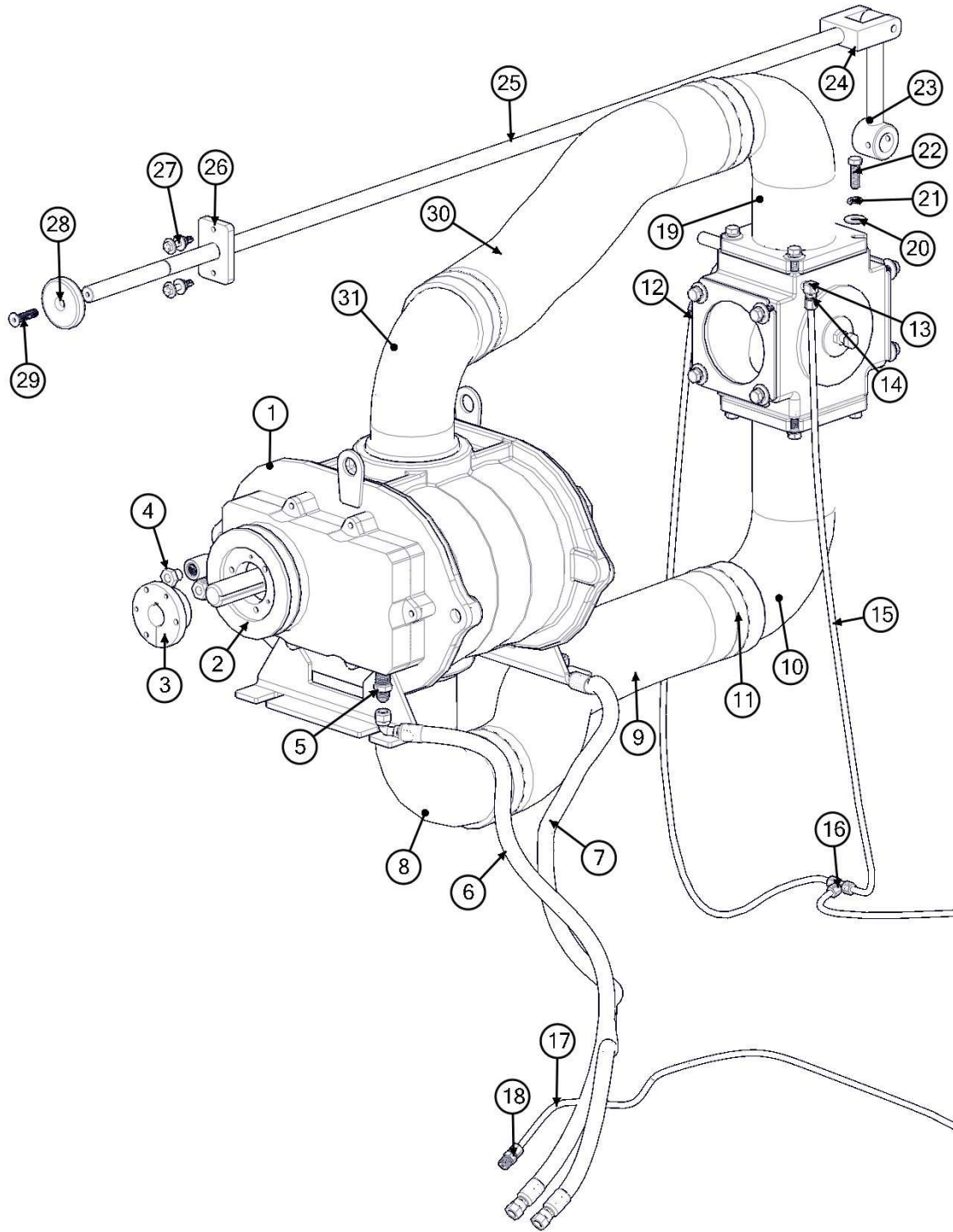

BLOWER ASSEMBLY PT1**4" 4-WAY VALVE**

BOM ID	Qty	Description
1	1	8040001 PUMP, VACUUM 1025
2	1	8090884 SHEAVE, 5.50"DIA QD2/5 V5.50
3	1	8090886 BUSHING, 1 1/8"DIA SDS 1 1/8
4	2	8048571 SIGHT GLASS
5	2	T400028 UNION 6MP_6MJ
6	1	8091100 HOSE ASSY VAC 6-35 ST-90 (BLOWER DRAIN FRONT)
7	1	8091101 HOSE ASSY VAC 6-40 ST-90 (BLOWER DRAIN REAR)
8	1	8049404 ELBOW, EXHAUST 4"OD 45
9	1	8092929-024.00 HOSE AG HOT AIR 4-24"
10	2	8091586 ELBOW WELDMENT (LONG)
11	4	8042606 HOSE CLAMP T-BOLT 4"
12	4	8043554 GASKET, 4-WAY VALVE
13	2	T401096 FITTING, ELBOW SHORT 90 BODY
14	2	T320309 FITTING,COMP 1_4T X 1_8M
15	1	8091601 TUBE, NYLON 1/4 X 24"LG
16	1	T402009 TEE 1_4TB X 1_4TB X 1_4TB
17	1	8091603 TUBE, NYLON 1/4 X 90 1/2"LG
18	1	T320308 FITTING,COMP 1_4T X 1_4M
19	1	8091585 ELBOW WELDMENT (SHORT)
20	18	U200060 WASHER, FLAT 3/8 ZP
21	16	U210060 WASHER, LOCK 3/8 ZP
22	16	U000440 SCREW,HC 3/8-16 X 1.25 ZP G5
23	1	8049588 VALVE, HANDLE
24	1	8049592 VALVE, HANDLE PUSH ROD END
25	1	8049595 ROD, 4-WAY VALVE
26	1	8049591 BUSHING, VALVE HANDLE PUSH ROD
27	2	U000100 SCREW,HC 1/4-20 X 1.50 ZP G5
28	1	8049593 HANDLE, GRIP VALVE PUSH ROD
29	1	U030065 SCREW, SFH 5/16-18 X 1.50 ZP G5
30	1	8092929-016.00 HOSE AG HOT AIR 4-16"
31	1	8090708 TUBE, BLOWER INPUT

BLOWER ASSEMBLY PT2
4" 4-WAY VALVE

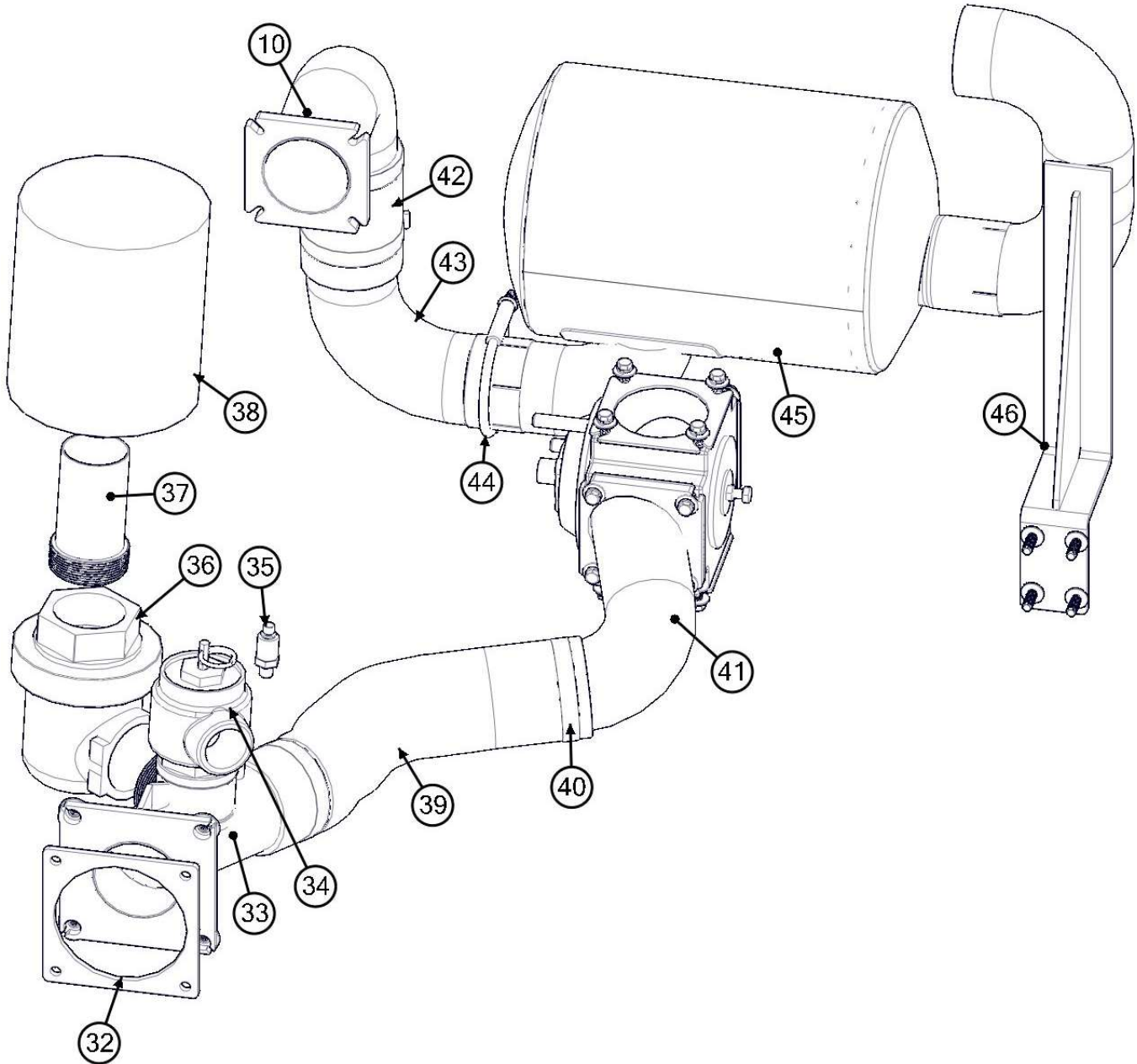

BLOWER ASSEMBLY PT2**4" 4-WAY VALVE**

BOM ID	Qty	Description
10	1	8091586 ELBOW WELDMENT (LONG)
32	1	8046191 GASKET, HEADER
33	1	8091040 HEADER, AIR FILTER 1025
34	1	8041035 PRESSURE RELIEF 1025
35	1	X000085 PRESSURE TRANSDUCER
36	1	8030866 VALVE, 3" AIR FILTER (SET 15"HG)
37	1	8045238 UNION EXHAUST 3IN OD_MNPT
38	1	8043553 FILTER, AIR 3" 245CFM
39	1	8048240 HOSE VAC AG SUCTION 4-16"
40	4	8042606 Hose Clamp T-Bolt 4in
41	1	8091587 ELBOW WELDMENT (ANGLED)
42	1	8090258 HOSE VAC AG SUCTION 4-12"
43	1	8040929 ELBOW, EXHAUST 4" 90
44	1	8031193 CLAMP U_BOLT 4in EXHAUST
45	1	8090802 SILENCER, 4" COWL
46	1	8090395 SILENCER OUTPUT TUBE WELDMENT

WATER PUMP ASSEMBLY

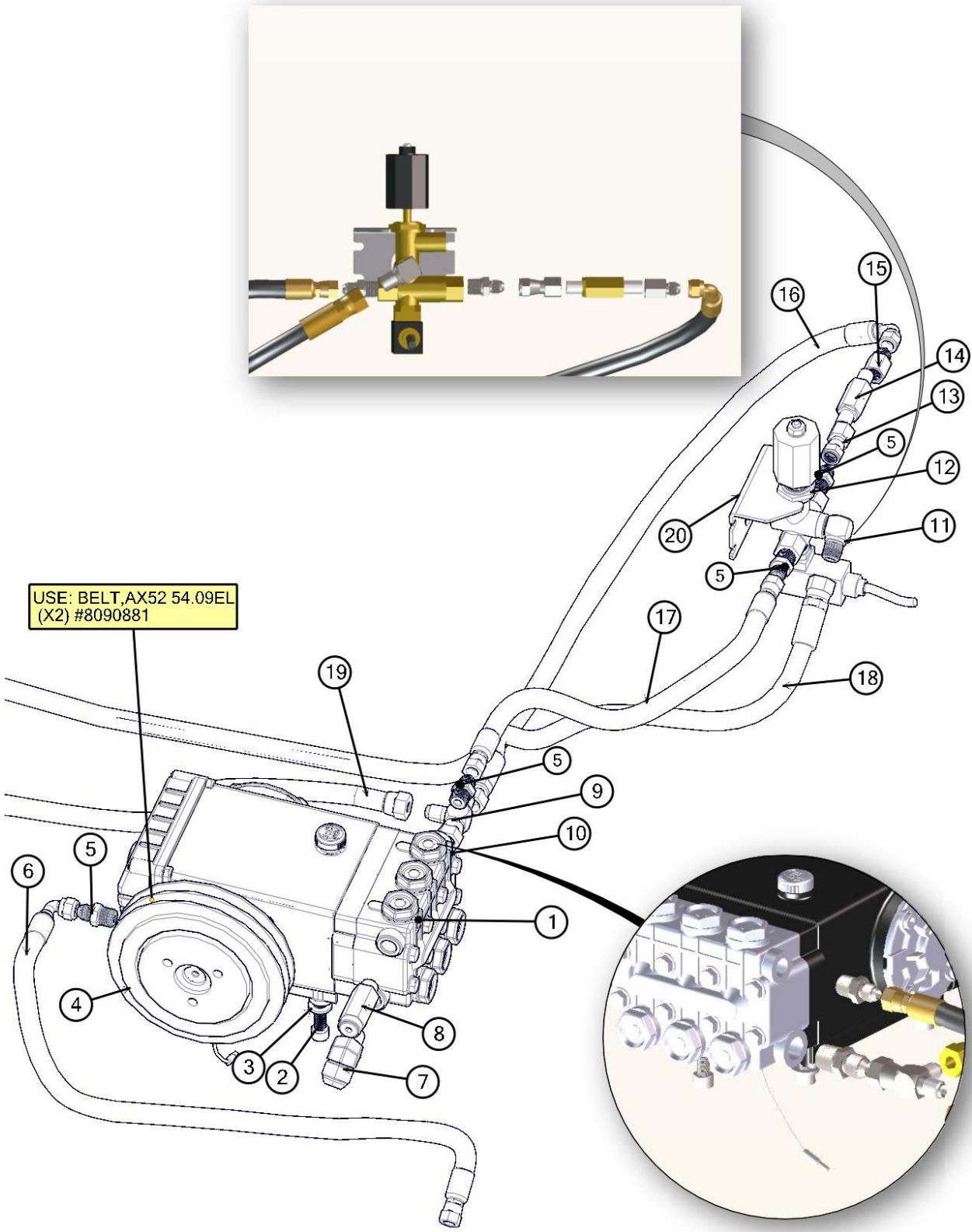

WATER PUMP ASSEMBLY

BOM ID	Qty	Name
1	1	8031388 PUMP, WATER
2	4	U001635 SCREW,HC 10MM X 1.25 X 30MM
3	4	U200302 WASHER, FLAT 12MM
4	1	8030961 CLUTCH, WATER PUMP TS2021
5	4	T400028 UNION 6MP-6MJ
6	1	8046898 HOSE ASSY VAC 6-27 ST-90 (WATER PUMP DRAIN)
7	1	T401561 ELBOW 8MP-12MJ 45
8	1	8030340 VALVE, SAFETY RELIEF 6GPM
9	1	T402155 TEE 8FJ-8MJ-8MJ
10	1	T400040 UNION 1/2MP-1/2MJ
11	1	T401120 ELBOW 90 6MP_8MJ
12	1	8048979 VALVE, UNLOADER BLUE W/SWITCH
14	1	8030923 FILTER, WATER HIGH PRESSURE
15	1	8031126 REDUCER 4FP_6MJ
16	1	8091363 HOSE VAC PUSH 8-132"
17	1	8091325 HOSE ASSY VAC 6-13 ST-ST
18	1	8041469 HOSE ASSY VAC 8-16 ST-ST
19	1	8091098 HOSE VAC PUSH 8-117"LG
20	1	8049905 BRACKET, UNLOADER VALVE

8031280 - WATER PUMP PARTS	
KIT #	INCL'D IN KIT
8031280-KIT1	4,5,6,7,8, (11)
8031280-KIT2	16
8031280-KIT3	41
8031280-KIT4	9,10

WATER TANK ASSEMBLY

125 GALLON

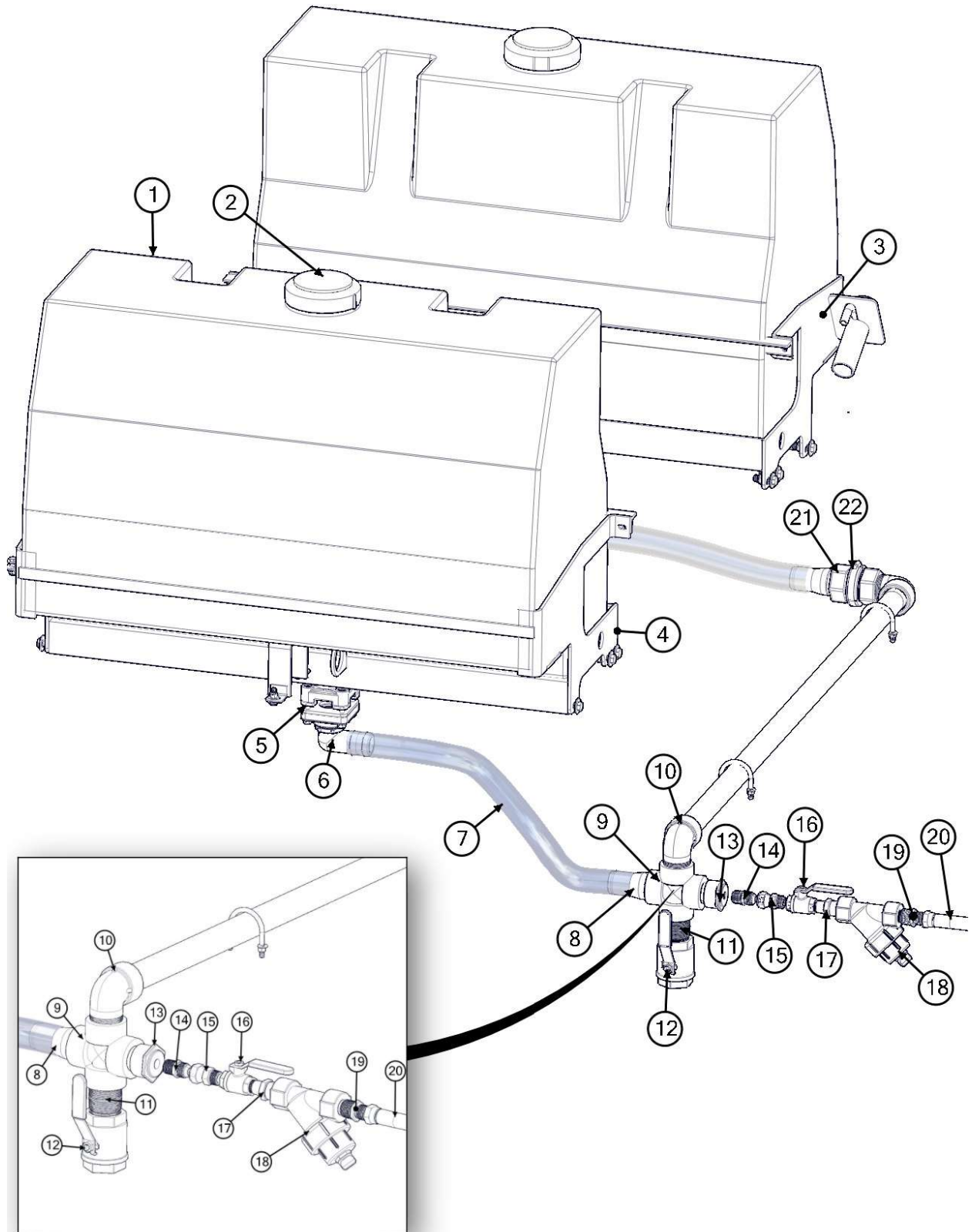

WATER TANK ASSEMBLY

125 GALLON

BOM ID	Qty	Description
1	2	8046162 TANK, WATER 125GAL
2	2	8041119 LID, WATER TANK 125GAL
3	1	8091183 BRACKET, WATER TANK 125GAL (STREET SIDE)
4	1	8091152 BRACKET, WATER TANK 125GAL (CURB SIDE)
5	2	8049750 BULKHEAD, 2" BOTTOM DRAIN
6	2	8090209 FITTING, ELBOW 2" HOSE BARB 90
7	1	8091785 HOSE, VAC CLEAR VINYL 2-30"LG
8	2	T410115 FITTING, 2"MNPT - 2"BARB STEEL
9	1	8091712 FITTING BANJO CROSS 2in NPT
10	2	8090207 FITTING, ELBOW 90 2" BANJO
11	1	8030409 NIPPLE CLOSE 2IN SCHD 40 IRON
12	1	8090233 VALVE_BALL 2IN W_LEVER HANDLE
13	1	8090208 FITTING, REDUCER BUSHING 2" X 3/4"
14	1	T400100 UNION 12MP_12MJ
15	1	T400101 UNION 12FJ_12MP
16	1	T000185 VALVE_BALL 3_4 FNPT BRASS
17	1	T404060 REDUCER 16MP_12MP
18	1	8040186 STRAINER, Y 1" BANJO
19	1	T400450 REDUCER 16MP_12MJ
20	1	8091092 HOSE VAC PUSH 12-26"
21	2	8030996 MANIFOLD, 2" BANJO FEMALE ADAPTER
22	1	8031000 CLAMP, 2" BANJO WORM

WATER TANK ASSEMBLY 50 GALLON

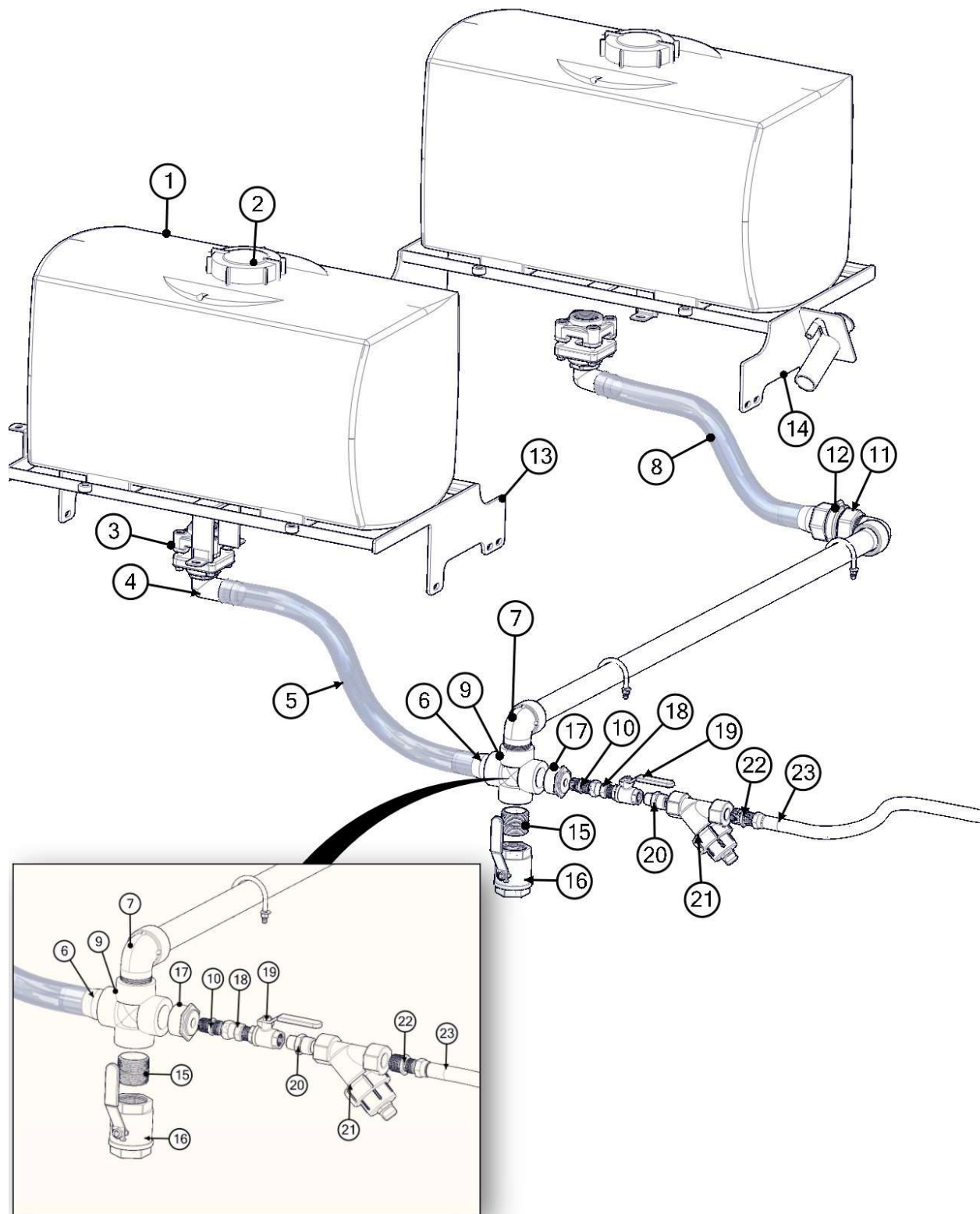

WATER TANK ASSEMBLY

50 GALLON

BOM ID	Qty	Name
1	2	8034151 TANK, WATER 50GAL
2	2	8034151-01 LID, 50 GAL WATER TANK
3	1	8091253 FRAME, WATER TANK 50GAL (STREET)
4	1	8091252 FRAME, WATER TANK 50GAL (CURB)
5	2	8049750 BULKHEAD, 2" BOTTOM DRAIN BANJO
6	2	8090209 FITTING, ELBOW 2" HOSE BARB 90
7	2	8090213 HOSE VAC CLEAR VINLY 2"-21"LG
8	1	8090206 FITTING, ELBOW 2" BANJO 45
9	2	8090204 FITTING, TEE 2" BANJO
10	1	8030409 NIPPLE CLOSE 2IN SCHD 40 IRON
11	1	8090233 VALVE_BALL 2IN W_LEVER HANDLE
12	1	8090211 FITTING, NIPPLE PIPE 2"NPT X 4"LG
13	2	8090207 FITTING, ELBOW 2" BANJO
14	1	8090208 FITTING, REDUCER BUSHING
16	1	T400101 UNION 12FJ-12MP
17	1	T000185 VALVE, BALL 3/4 FNPT BRASS
18	1	T404060 REDUCER 16MP-12MP
19	1	8040186 STRAINER, Y 1" BANJO
20	1	T400450 REDUCER 16MP-12MJ
21	1	8091092 HOSE VAC PUSH 12-26"
22	2	8030996 MANIFOLD, ADAPTER 2" BANJO (FEMALE)
23	1	8031000 CLAMP, 2" BANJO WORM
24	12	U000860 SCREW,HC 1/2-13 X 1.75 ZP G5
25	23	U200100 WASHER, FLAT 1/2 ZP
26	12	U160018 NUT, LOCK 1/2-13 NY ZP
27	2	T410115 FITTING, 2"MNPT-2"BARB STEEL

NOT SHOWN:

1 8090896 SWITCH,WATER TANK HORIZ

ANTIFREEZE/WATER REEL ASSEMBLY

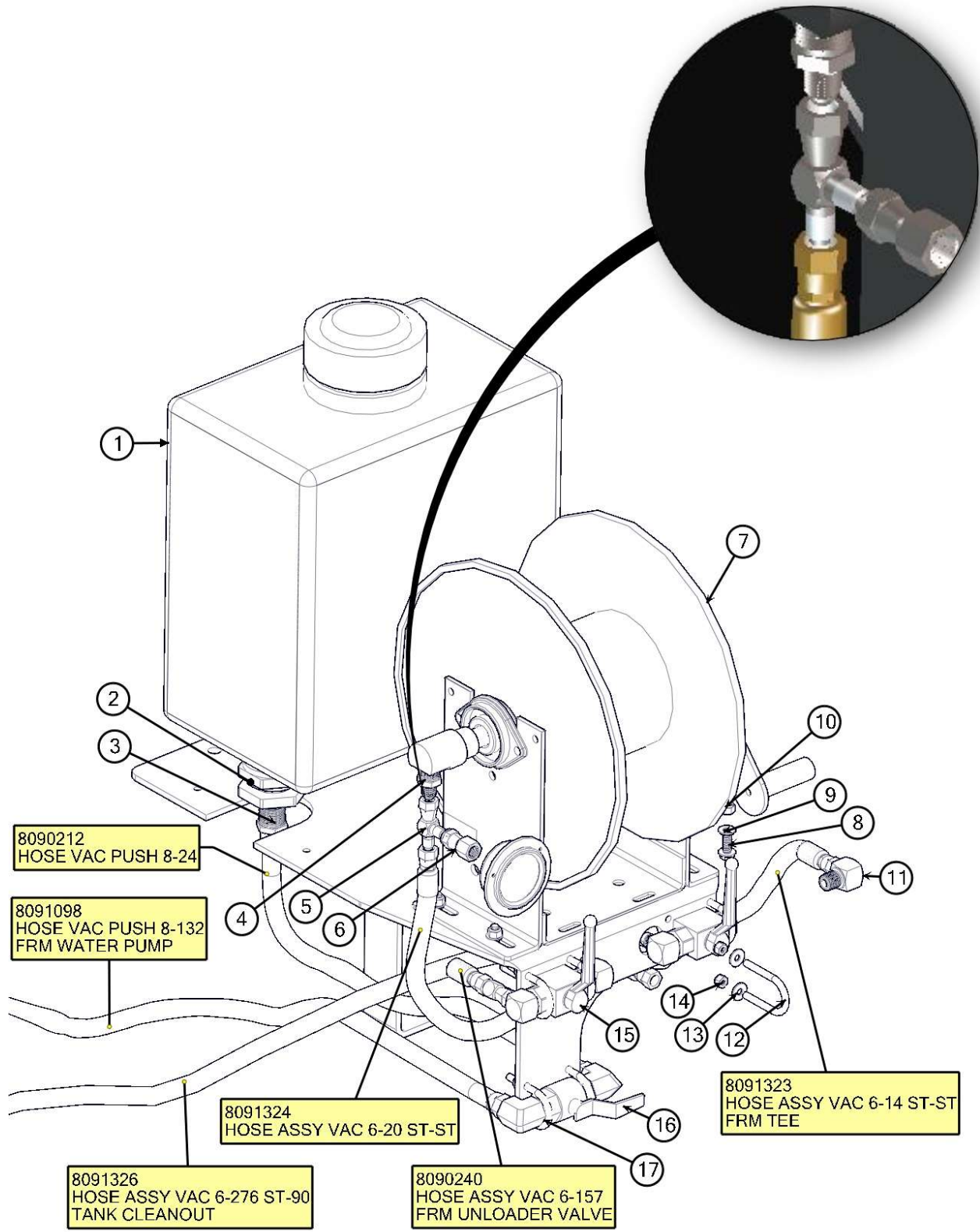

ANTIFREEZE/WATER REEL ASSEMBLY

BOM ID	Qty	Name
1	1	8049723 TANK, ANTIFREEZE 7GAL
2	1	8041148 BULKHEAD, 3/4"NPT PLASTIC
3	1	T400080 REDUCER, 12MP-8MJ
4	1	T400029 REDUCER 8MP_6MJ
5	2	T402153 TEE, 6FJ-6MJ-6MJ
6	1	8031125 REDUCER, 4FP-6FJ
7	1	8030879 REEL, WATER
8	4	U000200 SCREW,HC 5/16-18 X 1.00 ZP G5
9	8	U200040 WASHER, FLAT 5/16 ZP
10	4	U110040 NUT, HEX 5/16-18 NY ZP G2
11	4	T401102 ELBOW, 90 6MP-6MJ
12	6	U010017 U-BOLT, 1/4-20
13	11	U200020 WASHER, FLAT 1/4 ZP
14	12	U100020 NUT, HEX 1/4-20
15	2	8030351 VALVE, BALL 3/8 NPT
16	1	T000185 VALVE, BALL 3/4"FNPT BRASS
17	2	T401160 ELBOW, 90 12MP-8MJ

8041830 HOSE ASSY VAC 3/8" X 50' 4000PSI (HOSE for REEL)
8091355 FITTING, QD WATER 3/8"F - 3/8"FP

VACUUM TOOLS LAYOUT

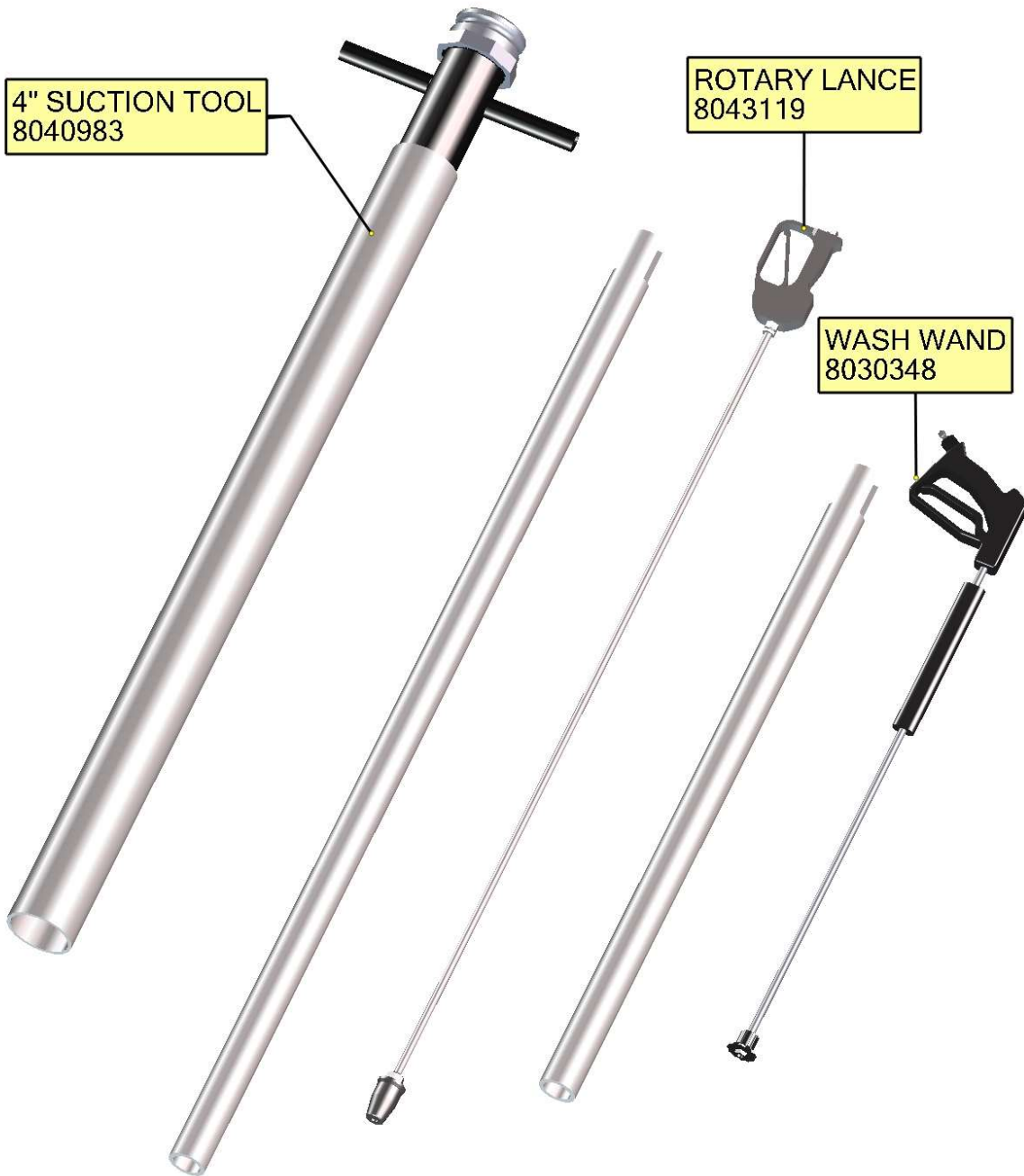

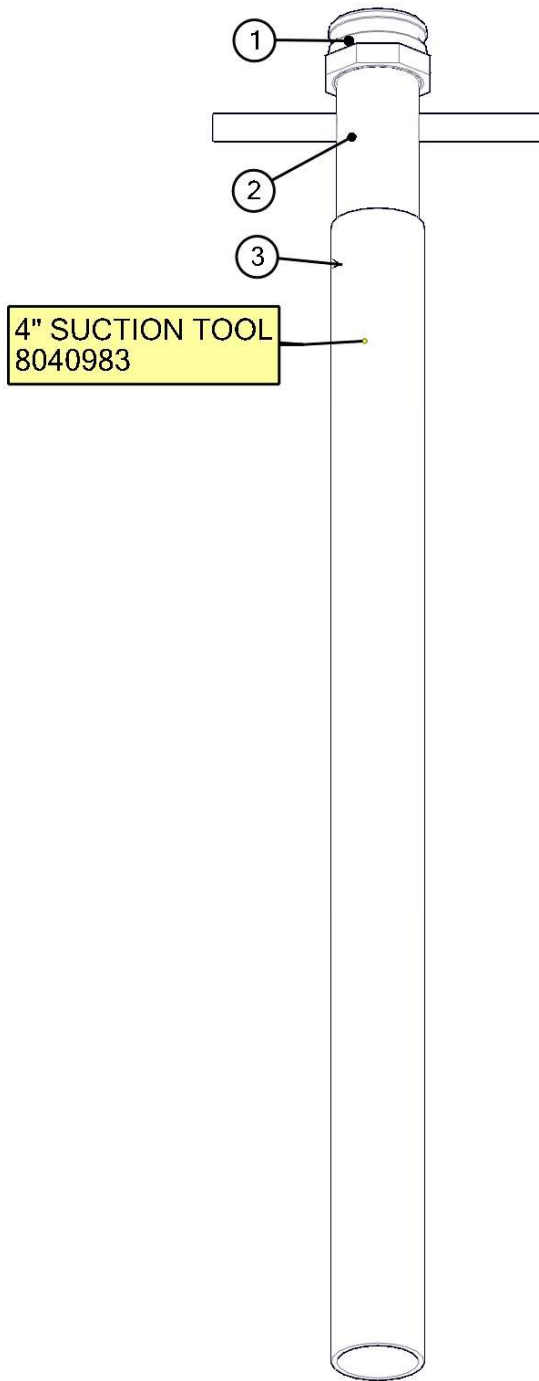

TOOLS**SUCTION TOOL**

BOM ID	Qty	Name
1	1	8030844 COUPLING, BANJO 4"
2	1	8040981 VAC TOOL HANDLE ASSEMBLY 4"
3	1	8040982 TUBE, VACUUM PVC 4"

TOOLS

ROTARY LANCE

8091356 - QUICK DISCONNECT, MALE 3/8
MUST ORDER SEPARATELY

ROTARY LANCE
8043119

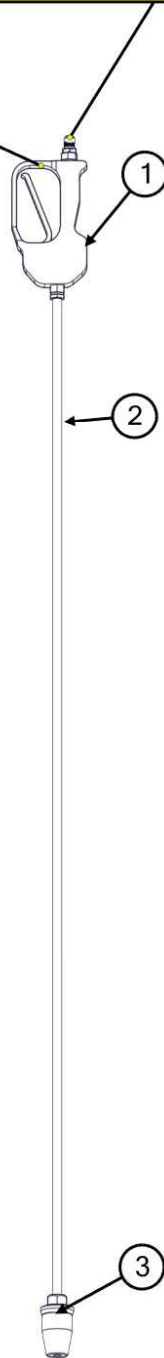

BOM ID	Qty	Name
1	1	8048567 GUN, SPRAY STRAIGHT
2	1	8043765 TUBE, CHROME 1/4NPT 60"LG
3	1	8048739 NOZZLE, ROTATING 055

* NOT SHOWN
 8092777 ROD RETAINING ASSEMBLY, TOOL STORAGE

TOOLS

WASH WAND

8091356 - QUICK DISCONNECT, MALE 3/8
MUST ORDER SEPARATELY

WASH WAND
8030348

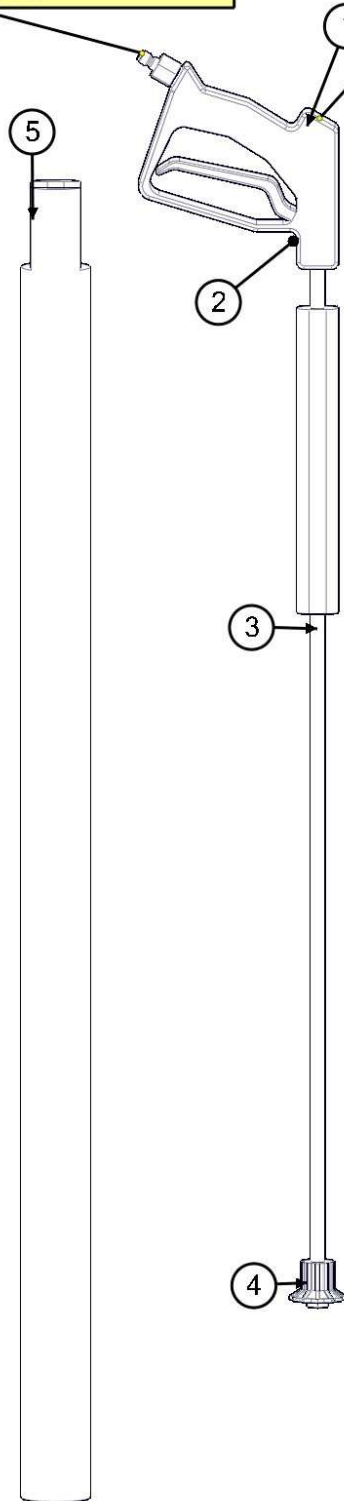

BOM ID	Qty	Name
1	1	8030348 WAND COMPLETE
2	1	8030928 TRIGGER ASSEMBLY
3	1	8030847 WAND
4	1	8031303 NOZZLE, #10 40DEG
5	1	8091383 STORAGE, TOOL PVC 2 1/2 X 48"LG

* NOT SHOWN

1 8092777 ROD RETAINING ASSEMBLY, TOOL STORAGE

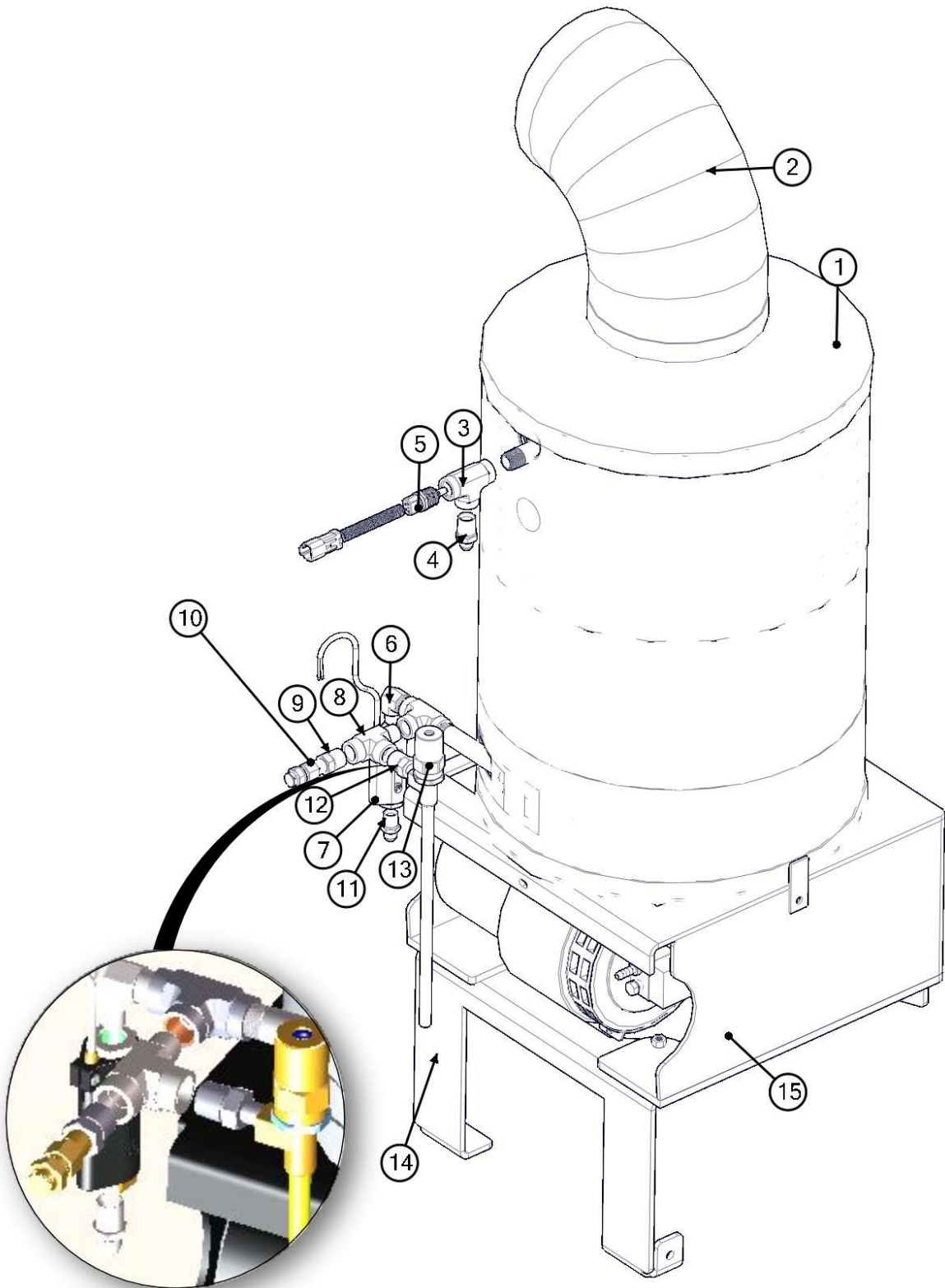

BOM ID	Qty	Name
1	1	8046448 HOT BOX, VERTICAL
2	1	8046535 ELBOW, 8" EXHAUST (AQUA-BLAST)
3	2	T402130 ADAPTER, TEE 8FP-8FP-8FP STEEL GALV
4	1	8031291 ADAPTER, STR 8MP-6MJ STEEL GALV
5	1	8048033 SWITCH, TEMPATURE 1/2 MP 100 & 165
6	1	T401136 ADAPTER, 90 DEG 8MP-6MP STEEL GALV
7	1	8047724 SWITCH, FLOW .375 NPT, 3A GRAVITY ACTUATED
8	1	T402156 ADAPTER, TEE 8MP-8MP-8FP STEEL
9	1	T400024 ADAPTER, STR 8MP-6FP STEEL GALV
10	1	8046976 VALVE, PRESSURE RELIEF BURST DISK WITH BODY 5,000 PSI
11	1	T400028 ADAPTER, STR 6MP-6MJ
12	1	T400123 FITTING, 1/2MP X 1/4MP
13	1	8048030 VALVE PRESSURE REGULATING
14	1	8090808 BRACKET, HOT BOX
15	1	8049685 SUB-FRAME, HOT BOX REMOVABLE

OPTIONS

STRONG-ARM ASSEMBLY

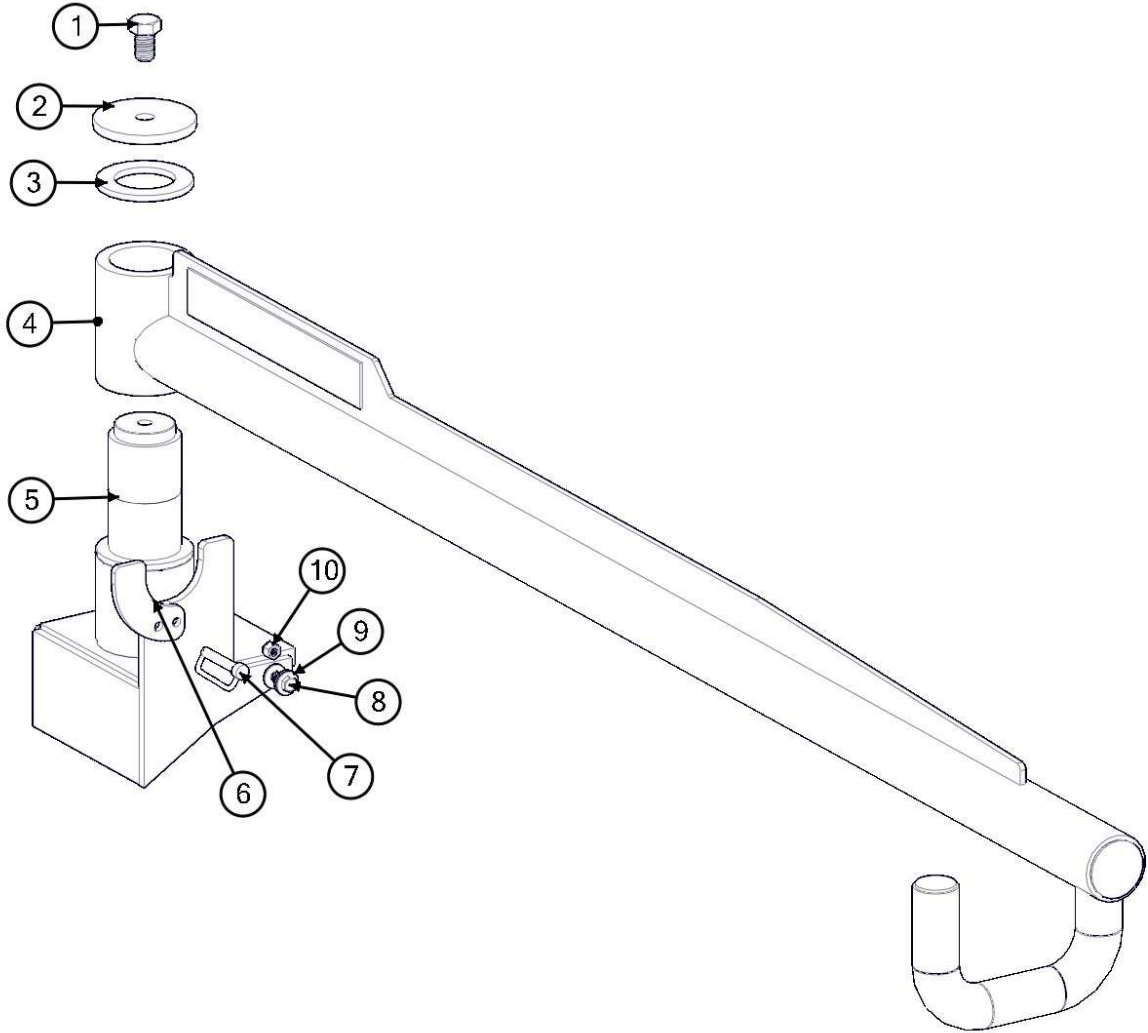

OPTIONS**STRONG-ARM
ASSEMBLY**

BOM ID	Qty	Name
1	1	U001355 SCREW,HC 3/4-10 X1 .25 ZP G5
2	1	8047085 CAP, TOP
3	2	8047077 FLANGE, WEAR PIVOT ARM MOUNT
4	1	8091158 STRONGARM WELDMENT
5	2	8047076 BEARING, PIVOT TUBE
6	1	8047089 RETAINER FRONT PLATE
7	1	8041213 PIN, SAFETY SNAP
8	1	U000440 SCREW,HC 3/8-16x1-25 ZP G5
9	3	U200060 WASHER, FLAT 3/8 ZP
10	1	U120110 NUT,LOCK .375-16 NY ZP

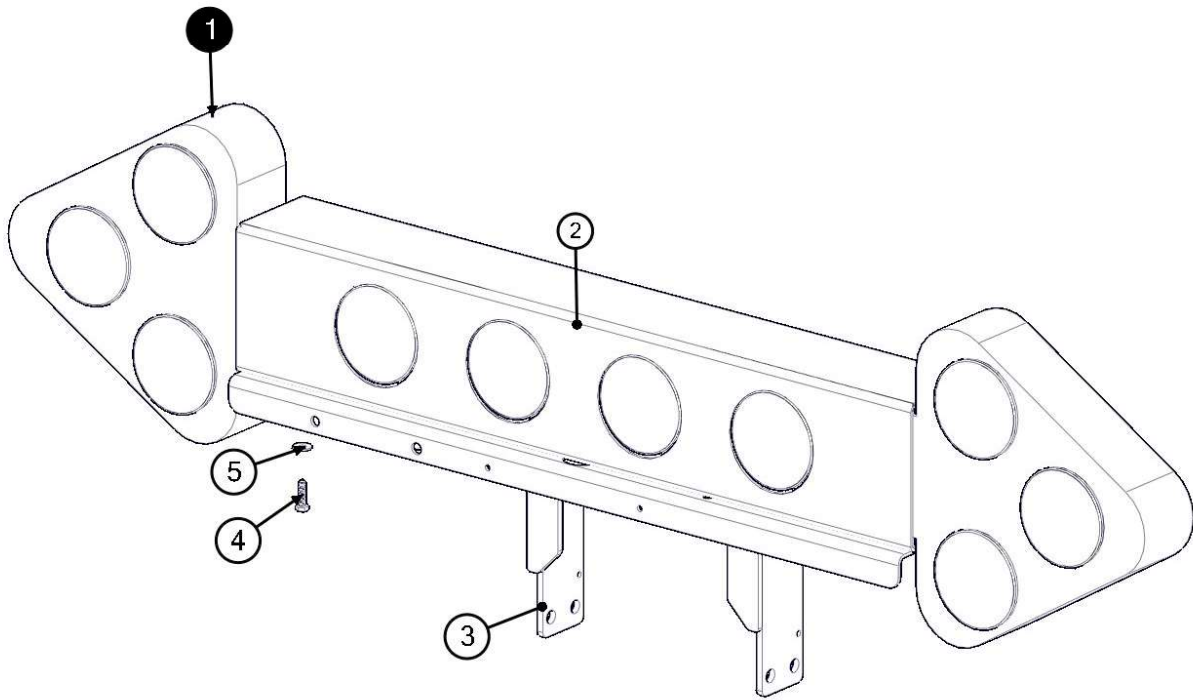

OPTIONS**ARROWBOARD
ASSEMBLY**

BOM ID	Qty	Name
1	1	8034190 VACUUM OPTION ARROWBOARD
2	1	8042197 ARROWBOARD
3	1	8048496 BRACKET, ARROWBOARD STRONGARM
4	4	U000060 SCREW,HC 1/4-20 X 1.00 ZP G5
5	4	U200020 WASHER, FLAT 1/4 ZP

PAGE LEFT BLANK

ROOTS

Blowers Compressors Exhausters

Universal URAI-DSL

Contents

Information Summary	Troubleshooting
Safety Precautions	Inspection & Maintenance
Operating Limitations	Data
Lubrication	Assembly Drawings
Operation	Parts List

Do These Things To Get The Most From Your ROOTS™ blower

- **Make sure both driving and driven equipment is correctly lubricated before start-up. See LUBRICATION.**
- In event of trouble during installation or operation, do not attempt repairs of ROOTS furnished equipment. Notify ROOTS, giving all nameplate information plus an outline of operating conditions and a description of the trouble. Unauthorized attempts at equipment repair may void ROOTS warranty.
- Units out of warranty may be repaired or adjusted by the owner. Good inspection and maintenance practices should reduce the needs for repairs.

NOTE: Information in this manual is correct as of the date of publication. ROOTS reserves the right to make design or material changes without notice, and without obligation to make similar changes without notice, and without obligation to make similar changes on equipment of prior manufacture.



Lubrication

For Units with Splash Lubrication on Both Ends

Bearings and oil seals are lubricated by the action of the timing gears or oil slingers which dip into the main oil sumps

causing oil to splash directly on gears and into bearings and seals. A drain port is provided below each bearing to prevent an excessive amount of oil in the bearings. Seals located inboard of the bearings in each headplate effectively retain oil within the sumps. Any small leakage that may occur should the seals wear passes into a cavity in each vented headplate and is drained downward.

Oil sumps on each end of the blower are filled by removing top vent plugs, Item (25), and filling until oil reaches the middle of the oil level sight gauge when the unit is not operating, Item (45 or 53), DO NOT FILL PAST THE MIDDLE OF THE SIGHT GLASS.

Initial filling of the sumps should be accomplished with the blower not operating, in order to obtain the correct oil level. Approximate oil quantities required for blowers of the various models and configurations are listed in Table 3. Use a good grade of industrial type non-detergent, rust inhibiting, anti-foaming oil and of correct viscosity per Table 2. ***ROOTS synthetic oil (Roots P/N 813-106-) is specified and recommended.** Roots does not recommend automotive type lubricants, as they are not formulated with the properties mentioned above.

The oil level may rise or fall on the gauge during operation, to an extent depending somewhat on oil temperature and blower speed.

Proper lubrication is usually the most important single consideration in obtaining maximum service life and satisfactory operation from the unit. Unless operating conditions are quite severe, a weekly check of oil level and necessary addition of lubricant should be sufficient. During the first week of operation, check the oil levels in the oil sumps about once a day, and watch for leaks. Replenish as necessary. Thereafter, an occasional check should be sufficient. It is recommended that the oil be changed after initial 100 hours of operation. Frequent oil changing is not necessary unless the blower is operated in a very dusty location.

Normal life expectancy of petroleum based oils is about 2000 hours with an oil temperature of about 180°F (82°C). As the oil temperature increases by increments of 15-18°F (8°C - 10°C), the life is reduced by half. Example: Oil temperatures of 210-216°F (99°C - 102°C) will produce life expectancy of 1/4 or 500 hours. Therefore, it is considered normal to have oil change periods of 500 hours with petroleum based oils.

Normal life expectancy of ROOTS™ Synthetic Oil is about 4000 to 8000 hours with an oil temperature of about 180°F (82°C). As the oil temperature increases by increments of 15-18°F (8°C - 10°C), the life is reduced by half. Example: Oil temperatures of 210-216°F (99°C - 102°C) will produce life expectancy of 1/4 or 1000 to 2000 hours.

NOTE: To estimate oil temperature, multiply the discharge temperature of the blower by 0.80. Example: if the discharge air temperature of the blower is 200° F, it is estimated that the oil temperature is 160° F.

*ROOTS™ Synthetic Oil & Grease is superior in performance to petroleum based products. It has high oxidation stability, excellent corrosion protection, extremely high film strength and low coefficient of friction. Typical oil change intervals are increased 2-3 times over petroleum based lubricants. Also, ROOTS™ Synthetic Oil is 100% compatible with petroleum based oils. Simply drain the oil in the blower and refill the reservoirs with ROOTS™ Synthetic Oil to maintain optimum performance of your ROOTS™ blower.

Operation

Before operating a blower under power for the first time, recheck the unit and the installation thoroughly to reduce the likelihood of avoidable troubles. Use the following procedure check list as a guide, but consider any other special conditions in the installation.

- Be certain that no bolts, tools, rags, or debris have been left in the blower air chamber or piping.
- If an outdoor intake without filter is used, be sure the opening is located so it cannot pick up dirt and is protected by a strong screen or grille. Use of the temporary protective screen as described under INSTALLATION is strongly recommended.
- Recheck blower leveling, drive alignment and tightness of all mounting bolts if installation is not recent. If belt drive is used, adjust belt tension correctly.
- Turn drive shaft by hand to make sure impellers still rotate without bumping or rubbing at any point.
- Ensure oil levels in the main oil sumps are correct.
- Check lubrication of driver. If it is an electric motor, be sure that power is available and that electrical overload devices are installed and workable.
- Open the manual unloading valve in the discharge air line. If a valve is in the inlet piping, be sure it is open.
- Bump blower a few revolutions with driver to check that direction of rotation agrees with arrow near blower shaft, and that both coast freely to a stop.

After the preceding points are cleared, blower is ready for trial operation under "no-load" conditions. The following procedure is suggested to cover this initial operation test period.

- a. Start blower, let it accelerate to full speed, then shut off. Listen for knocking sounds, both with power on and as speed slows down.
- b. After blower comes to a complete stop, repeat above, but let blower run 2 or 3 minutes. Check for noises, such as knocking sounds.
- c. After blower comes to a complete stop, operate blower for about 10 minutes unloaded. Check oil levels. Observe cylinder and headplate surfaces for development of hot spots such as burned paint, indicating impeller rubs. Be aware of any noticeable increase in vibration.

Assuming that all trials have been satisfactory, or that necessary corrections have been made, the blower should now have a final check run of at least one hour under normal operating conditions. After blower is restarted, gradually

close the discharge unloading valve to apply working pressure. At this point it is recommended that a pressure gauge or manometer be connected into the discharge line if not already provided, and that thermometers be in both inlet and discharge lines. Readings from these instruments will show whether pressure or temperature ratings of the blower are being exceeded.

During the final run, check operating conditions frequently and observe the oil levels at reasonable intervals. If excessive noise or local heating develops, shut down immediately and determine the cause. If either pressure rise or temperature rise across the blower exceeds the limit specified in this manual, shut down and investigate conditions in the piping system. Refer to the TROUBLESHOOTING CHECKLIST for suggestions on various problems that may appear.

The blower should now be ready for continuous duty operation at full load. During the first few days make periodic checks to determine whether all conditions remain steady, or at least acceptable. This may be particularly important if the blower is supplying air to a process system where conditions can vary. At the first opportunity, stop the blower and clean the temporary inlet protective screen. If no appreciable amount of debris has collected, the screen may be removed. See comments under INSTALLATION. At this same time, verify leveling, coupling alignment or belt tension, and mounting bolt tightness.

Should operating experience prove that blower capacity is a little too high for the actual air requirements, a small excess may be blown off continuously through the manual unloading or vent valve. Never rely on the pressure relief valve as an automatic vent. Such use may cause the discharge pressure to become excessive, and can also result in failure of the valve itself. If blower capacity appears to be too low, refer to the TROUBLESHOOTING CHECKLIST.

Vibration Assessment Criteria

With measurements taken at the bearing locations on the housings, see chart below for an appropriate assessment guide for rotary lobe blowers rigidly mounted on stiff foundations.

In general, blower vibration levels should be monitored on a regular basis and the vibration trend observed for progressive or sudden change in level. If such a change occurs, the cause should be determined through spectral analysis.

As shown on the chart below, the level of all pass vibration will determine the need to measure discrete frequency vibration levels and the action required.

All Pass Vibration (in/sec)	Discrete Frequency Vibration (in/sec)	Action
0.45 or less	N/R	Acceptable
Greater than 0.45 but 1.0 or less	0.45 or less @ any frequency	Acceptable
	Greater than 0.45 @ any frequency	Investigate
Greater than 1.0	Less than 1.0	Investigate
	Greater than 1.0	Investigate

Troubleshooting Checklist

Trouble	Item	Possible Cause	Remedy
No flow	1	Speed too low	Check by tachometer and compare with published performance
	2	Wrong rotation	Compare actual rotation with Figure 1 Change driver if wrong
	3	Obstruction in piping	Check piping, valves, silencer to assure open flow path
Low capacity	4	Speed too low	See item 1, If belt drive, check for slippage and readjust tension
	5	Excessive pressure rise	Check inlet vacuum and discharge pressure and compare with Published performance
	6	Obstruction in piping	See item 3
	7	Excessive slip	Check inside of casing for worn or eroded surfaces causing excessive clearances
Excessive power	8	Speed too high	Check speed and compare with published performance
	9	Excessive pressure rise	See item 5
	10	Impeller rubbing	Inspect outside of cylinder for high temperature areas, then check for impeller contact at these points. Correct blower mounting, drive alignment
	11	Scale, sludge, rust or product build up	Clean blower appropriately
Damage to bearings or gears	12	Inadequate lubrication	Check oil sump levels in gear and drive end headplates
	13	Excessive lubrication	Check oil levels. If correct, drain and refill with clean oil of recommended grade
	14	Excessive pressure rise	See item 5
	15	Coupling misalignment	Check carefully. Realign if questionable
	16	Excessive belt tension	Readjust for correct tension
Vibration	17	Misalignment	See item 15
	18	Impellers rubbing	See item 10
	19	Worn bearings/gears	Check gear backlash and condition of bearings, and replace as indicated
	20	Unbalanced or rubbing impeller	Scale or process material may build up on casing and impellers, or inside impellers. Remove build-up to restore original clearances and impeller balance
	21	Driver or blower loose	Tighten mounting bolts securely
	22	Piping resonances	Determine whether standing wave pressure pulsations are present in the piping
	23	Scale/sludge build-ups	Clean out interior of impeller lobes to restore dynamic balance
Driver stops, or will not start	24	Casing strain	Re-work piping alignment to remove excess strain
	25	Impeller stuck	Check for excessive hot spot on headplate or cylinder. See item 10. Look for defective shaft bearing and/or gear teeth
	26	Scale, sludge, rust or product build-up	Clean blower appropriately
Excessive breather	27	Broken seal	Replace seals
Blow-by or excessive oil leakage to vent area	28	Defective O-ring	Replace seals and O-ring
Excessive oil leakage in vent area	29	Defective/plugged breather	Replace breather and monitor oil leakage
	30	Oil level too high	Check sump levels in gear and drive headplates.
	31	Oil type or viscosity incorrect	Check oil to insure it meets recommendations. Drain then fill with clean oil of recommended grade.
	32	Blower running hot	Check blower operating conditions to ensure they are within the operating limitations defined in this manual.

Inspection & Maintenance: Universal RAI® series blowers

A good program of consistent inspection and maintenance is the most reliable method of minimizing repairs to a blower. A simple record of services and dates will help keep this work on a regular schedule. Basic service needs are:

- Lubrication
- Checking for hot spots
- Checking for increases or changes in vibration and noise
- Recording of operating pressures and temperatures

Above all, a blower must be operated within its specified rating limits, to obtain satisfactory service life.

A newly installed blower should be checked often during the first month of full-time operation. Attention there after may be less frequent assuming satisfactory performance.

Lubrication is normally the most important consideration and weekly checks of lubricant levels in the gearbox and bearing reservoirs should be customary. Complete oil change schedules are discussed under **LUBRICATION**.

Driver lubrication practices should be in accordance with the manufacturer's instructions. If direct connected to the blower through a lubricated type coupling, the coupling should be checked and greased each time blower oil is changed. This will help reduce wear and prevent unnecessary vibration. In a belted drive system, check belt tension periodically and inspect for frayed or cracked belts.

In a new, and properly installed, unit there is no contact between the two impellers, or between the impellers and cylinder or headplates. Wear is confined to the bearings (which support and locate the shafts) the oil seals, and the timing gears. All are lubricated and wear should be minimal if clean oil of the correct grade is always used. Seals are subject to deterioration as well as wear, and may require replacement at varying periods.

Shaft bearings are designed for optimum life under average conditions with proper lubrication and are critical to the service life of the blower. Gradual bearing wear may allow a shaft position to change slightly, until rubbing develops between impeller and casing. This will cause spot heating, which can be detected by observing these surfaces. Sudden bearing failure is usually more serious. Since the shaft and impeller are no longer supported and properly located, extensive general damage to the blower casing and gears is likely to occur.

Oil seals should be considered expendable items, to be replaced whenever drainage from the headplate vent cavity becomes excessive or when the blower is disassembled for

any reason. Some oil seal leakage may occur since an oil film under the lip is required for proper operation. Periodically leaked oil should be wiped off from surfaces. Minor seal leakage should not be considered as indicating seal replacement.

Timing gear wear, when correct lubrication is maintained, should be negligible. Gear teeth are cut to provide the correct amount of backlash, and gears correctly mounted on the shafts will accommodate a normal amount of tooth wear without permitting contact between lobes of the two impellers. However, too high an oil level will cause churning and excessive heating. This is indicated by unusually high temperature at the bottom of the gear housing. Consequent heating of the gears will result in loss of tooth-clearance, backlash and rapid wear of the gear teeth usually will develop. Continuation of this tooth wear will eventually produce impeller contacts (knocking), and from this point serious damage will be unavoidable if blower operation is continued. A similar situation can be produced suddenly by gear tooth fracture, which is usually brought on by sustained overloading or momentary shock loads.

Problems may also develop from causes other than internal parts failure. Operating clearances within a blower are only a few thousandths of an inch. This makes it possible for impeller interference or casing rubs to result from shifts in the blower mounting, or from changes in piping support. If this type of trouble is experienced, and the blower is found to be clean, try removing mounting strains. Loosen blower mounting bolts and reset the leveling and drive alignment. Then tighten mounting again, and make sure that all piping meets blower connections accurately and squarely. Foreign materials in the blower will also cause trouble, which can only be cured by disconnecting the piping and thoroughly cleaning the blower interior.

A wide range of causes & solutions for operating troubles are covered in the **TROUBLE SHOOTING CHECKLIST**. The remedies suggested should be performed by qualified mechanics with a good background. Major repairs generally are to be considered beyond the scope of maintenance, and should be referred to an authorized Roots distributor.

Warranty failures should not be repaired at all, unless specific approval has been obtained through Roots before starting work. Unauthorized disassembly within the warranty period may void the warranty.

Figure 2 - Allowable Overhung Loads for V-Belt Drives Universal RAI®/URAI®-DSL Units

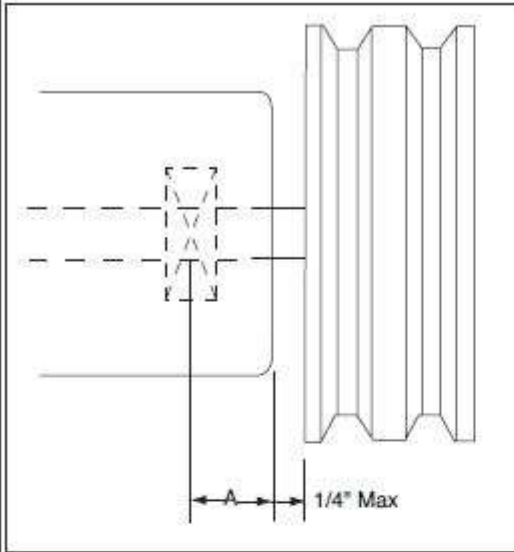

$$\text{Belt Pull lbs} = \frac{252100 \cdot \text{Motor HP}}{\text{Blower RPM} \cdot \text{Sheave Diameter}}$$

$$\text{Shaft Load (lb.in)} = \text{Belt Pull} \cdot \left(A + \frac{1}{4} + \frac{\text{Sheave Width}}{2} \right)$$

Frame Size	Dimension "A"	Max Allowable Shaft Load (lb-in)	Min Sheave Diameter
59	1.13	1,325	6.00

NOTE:

Arc of sheave belt contact on the smaller sheave not to be less than 170°

Driver to be installed on the inlet side for vertical units, and on the drive shaft side for horizontal units.

Roots recommends the use of two or more 3V, 5V or 8V matched set or banded belts and sheaves.

Specified Lubricants

ROOTS Synthetic Oil: ISO-VG-320 Grade

Part Number

Quart 13106004

Gallon 13106005

Case (12 qts) 13106007

ROOTS Synthetic Oil: ISO-VG-220 Grade

Part Number

Quart 13106001

Gallon 13106002

Case (12 qts) 13106008

ROOTS Synthetic Oil: ISO-VG-150 Grade

Part Number

Quart 13106020

Gallon 13106021

Case (12 qts) 13106023

5 Gallon Pail 13106022

55 Gallon Drum 13106025

Drive End Breather Orientation for URA-DSL blowers with Oil Lube

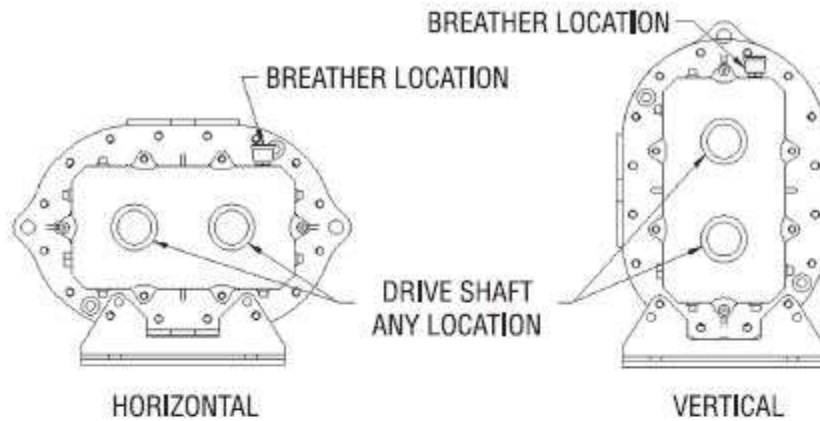

URAI DSL BREATHER ORIENTATION

Table 1 - URAI, URAI-DSL Blowers,
Maximum Allowable Operating Conditions

Frame Size	Gear Diameter (Inch)	Speed RPM	Temp. Rise Deg F (Deg C)	Delta Pressure PSI (mbar)	Inlet Vacuum INHG (mbar)
59	5	2,850	225 (125)	7 (483)	15 (500)

Table 2 - Recommended Oil Grades

Ambient Temperature °F (°C)	ISO Viscosity No.
Above 90° (32°)	320
32° to 90° (0° to 32°)	220
0° to 32° (-18° to 0°)	150
Below 0° (-18°)	100

Ambient temperature is defined as the temperature of the space in which the blower and drive are located.

Table 3 - Approximate Oil Sump Capacities

These capacities are provided to assist in stocking the correct amount of oil. Exact sump capacities may differ slightly. See "Lubrication" section for proper filling instructions.

URAI-DSL Splash Lubricated Blowers

Frame Size	Gear End Capacity Fl. Oz (Liters)	Drive End Capacity Fl. Oz. (Liters)
59	27.6 (.82)	14.8 (.44)

Basic Connection & Drive Shaft Information

URAI DSL AIR BLOWERS (with Dual Splash Lubrication DSL)

BOM#	FRAME SIZE	INLET/DISCHARGE CONN.	SHAFT DIAMETER	BARE WEIGHT
T30361020	59	4" NPT	1.125	209

Universal RAI air blowers include detachable mounting feet which permit vertical or horizontal installation. The units are center driven for rotation in either direction. The bearings on the URAI are grease lubricated on the drive end and splash lubricated on the gear end. The URAI-DSL is splash lubricated on BOTH ends.

Table 2 - Recommended Oil Grades

Ambient Temperature °F (°C)	ISO Viscosity No.
Above 90° (32°)	320
32° to 90° (0° to 32°)	220
0° to 32° (-18° to 0°)	150
Below 0° (-18°)	100

Ambient temperature is defined as the temperature of the space in which the blower and drive are located.

Table 3 - Approximate Oil Sump Capacities

These capacities are provided to assist in stocking the correct amount of oil. Exact sump capacities may differ slightly. See "Lubrication" section for proper filling instructions.

URAI-DSL Splash Lubricated Blowers

Frame Size	Gear End Capacity Fl. Oz (Liters)	Drive End Capacity Fl. Oz. (Liters)
59	27.6 (.82)	14.8 (.44)

Basic Connection & Drive Shaft Information

URAI DSL AIR BLOWERS (with Dual Splash Lubrication DSL)

BOM#	FRAME SIZE	INLET/DISCHARGE CONN.	SHAFT DIAMETER	BARE WEIGHT
T30361020	59	4" NPT	1.125	209

Universal RAI air blowers include detachable mounting feet which permit vertical or horizontal installation. The units are center fired for rotation in either direction. The bearings on the URAI are grease lubricated on the drive end and splash lubricated on the gear end. The URAI-DSL is splash lubricated on BOTH ends.

PAGE LEFT BLANK



MODEL MSR-DC OIL BURNER



MODEL MSR-DC SPECIFICATIONS

FIRING CAPACITIES - MODEL MSR-DC

0.50 To 2.75 GALLONS PER HOUR

70,000 TO 385,000 BTU/HR INPUT

FUELS - MODEL MSR-DC

Use No. 1 or No. 2 Heating Oil (ASTM D-396), Kerosene, Diesel or Jp8 Jet Fuel.

NEVER attempt to use gasoline as a fuel for your burner, as it is more combustible and could result in a serious explosion.

NEVER burn garbage or refuse in the heating unit.

NEVER try to ignite by tossing burning paper or other materials into the heating unit.

NEVER burn waste or crankcase oil in the heating unit.

ELECTRICAL - MODEL MSR-DC

Power supply 13.0VDC Minimum (at Battery)

Motor 4500 RPM (Std) or 3950 RPM (low RPM), Ball Bearing, Permanent Magnet

Ignition 20,000V/28MA/50VA Secondary, Intermittent Duty Electronic Ignitor

DIMENSIONS - MSR-DC (Standard)

Height.....12½"

Width13"

Depth6¼"

FUEL UNIT

Suntec and DanFoss brands

MOUNTING

Rigid Flange, Adjustable Flange or Base mount.

DC OIL BURNER ELECTRICAL CONSIDERATIONS

- * Not all generators are equally capable. A minimum of 13.0 volts must be provided at the battery.
- * Generators should be operated at the maximum rated RPM during burner operation.
- * Good quality batteries are strongly suggested. Batteries with higher Cold Cranking Amp (CCA) rating and deep draw/marine type batteries are recommended.
- * Use automotive rated battery cabling. All other wiring should be OEM suggested wire type and gauge.
- * Protect all wiring connection points with dielectric grease.
- * Ambient temperature impacts electrical requirements. Higher temperatures will result in higher amp draws.
- * Increased pump operating pressure settings will increase amp draw.
- * Higher gallon rate nozzles and accompanying wider air band openings will increase amp draw.

INSTALLATION OF BURNER

INSTALLATION OF THE BURNER MUST BE DONE BY A QUALIFIED INSTALLER IN ACCORDANCE WITH REGULATIONS OF THE NATIONAL FIRE PROTECTION STANDARD FOR OIL-BURNING EQUIPMENT, NFPA NO. 31, AND IN COMPLETE ACCORDANCE WITH ALL LOCAL CODES AND AUTHORITIES HAVING JURISDICTION.

A QUALIFIED INSTALLER IS THE PERSON WHO IS RESPONSIBLE FOR THE INSTALLATION AND ADJUSTMENT OF THE EQUIPMENT AND WHO IS LICENSED TO INSTALL OIL-BURNING EQUIPMENT IN ACCORDANCE WITH ALL CODES AND ORDINANCES. WARRANTY IS VOIDED IF NOT INSTALLED BY SERVICE PERSON.

**THESE INSTRUCTIONS SHOULD BE AFFIXED TO THE BURNER
OR ADJACENT TO THE HEATING APPLIANCE.**

TO THE CLEANING EQUIPMENT OWNER

Since 1970, Wayne has supplied the hot water pressure washer cleaning equipment industry with oil burners. You are obtaining a quality burner unsurpassed in engineering design and product development. It will provide you with many years of efficient trouble-free operation, if properly installed and serviced. Please read this manual carefully.



Wayne warrants its burners specifically to those who have purchased it for resale, including your dealer. If, in any case, you have a problem with your burner, or its installation, you should contact your dealer or the cleaning equipment manufacturer for assistance.

FUEL UNITS AND OIL LINES

The model MSR-DC oil burner is provided with a single stage 3450 RPM fuel unit with by-pass plug removed for a single pipe installation; the by-pass plug for two pipe (inlet and return) is provided in the plastic bag attached to the fuel unit.

The installation of fuel filters are recommended. Check supply tank for sludge accumulation and leakage. Use only flare fittings on all piping and connections since compression fittings will eventually leak. With the system running, the vacuum should not exceed 12" mercury for single stage units. For ease of servicing, install a shut off valve near burner.

WIRING

The MSR-DC oil burner must be electrically wired and GROUNDED in accordance with local codes or in their absence, with National Electric Code ANS/NFPA No. 70-latest edition.

This oil burner requires a 12-volt DC power source. Use copper wire only not lighter than #12 awg. If a fused disconnect is used, it should be fused for a minimum of 20 amps. Refer to the wiring diagram in this manual or cleaning equipment manufacturers manual making sure the burner and controls are wired correctly.

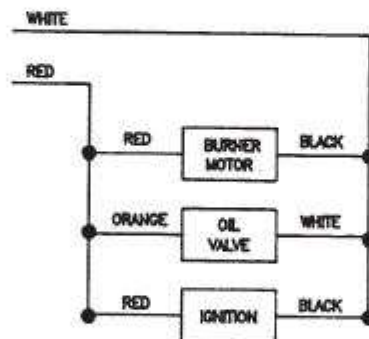

AIR SUPPLY FOR COMBUSTION

The oil burner fired hot water pressure washer shall not be installed in an area where facilities for normal air circulation or infiltration are so limited as to interfere with ready attainment of all necessary for proper combustion and venting. When the heating appliance is installed in a confined space, two permanent openings shall be provided. One near the top of the enclosure and one near the bottom. Each opening shall have a free area of not less than one square inch per 1000 BTU per hour (140 square inch per gph) of the total input rating of all the appliances in the enclosure. When the building is of unusually tight construction, has an air ventilating system, exhaust fans, process dryer or vented fireplaces, it is recommended that combustion air be supplied through two permanent openings. The openings shall communicate directly, or by means of ducts, with outdoors or such spaces (attic or crawl) that freely communicate with outdoors. Avoid linty environments. For additional venting information, refer to the regulations of the National Fire Protection Standard for oil burning equipment, ANSI/NFPA NO. 31-latest edition, or the cleaning equipment manufacturers recommendations.

NOZZLE AND AIR HANDLING PARTS SELECTION

IMPORTANT: Thorough combustion and performance testing was done to establish the correct nozzle type and air handling parts on this MSR-DC oil burner. Under circumstance attempt to replace or alter the oil burner nozzle type or air handling parts (stainless steel flamelock, air cone, electrode support style static disc, blower wheel or slotted air circumstances attempt to fire the MSR-DC oil burner under its 1.00 gph minimum or over its 2.75 gph maximum input rating.



To remove the gun assembly once the burner has been installed on the appliance remove the ignitor/housing cover screw and loosen the screw in the hold-down clip and swing open the transformer. Next, disconnect the copper oil line where it attaches with a 7/16" hex flare nut on the gun assembly oil line adapter fitting and remove the 9/16" hex gun assembly locknut. Now, grasp the rear of the gun assembly where the oil line fitting adapter exits through the housing and pull oil line fitting adapter to the right out of the housing slot and slot plate cover. Gently lift, do not force, the rear of the gun assembly, rotating the oil line fitting adapter up a 45 degrees pulling the entire gun assembly out of the air tube and housing opening.

The recommended can be installed into the nozzle body adapter using the following steps. With the gun assembly removed from the burner, loosen the electrode clamp screw and rotate the electrodes up, out of the way of a nozzle wrench. Now, thread the nozzle into the adapter finger tight then tighten securely with a nozzle wrench. **CAUTION:** Do not over tighten. Next, reposition the electrodes as shown in figure 1. At this time reinstall the gun assembly into the burner using the preceding steps in reverse order. Position the nozzle face forward to a 5/16" setting behind the stainless steel air cone as shown in figure 1. Once in the required position, replace the 9/16" hex lock nut and the 7/16" hex flare nut on the gun assembly and tighten the slot cover screw (see figure 2).

CAUTION: Close the ignitor and observe for spring contact with the brass buss bars, taking care not to pinch the ignition transformer lead wires between the housing and cover plate. Reinstall the ignitor/housing cover screw and tighten the screw in the hold down clip (see figure 2).

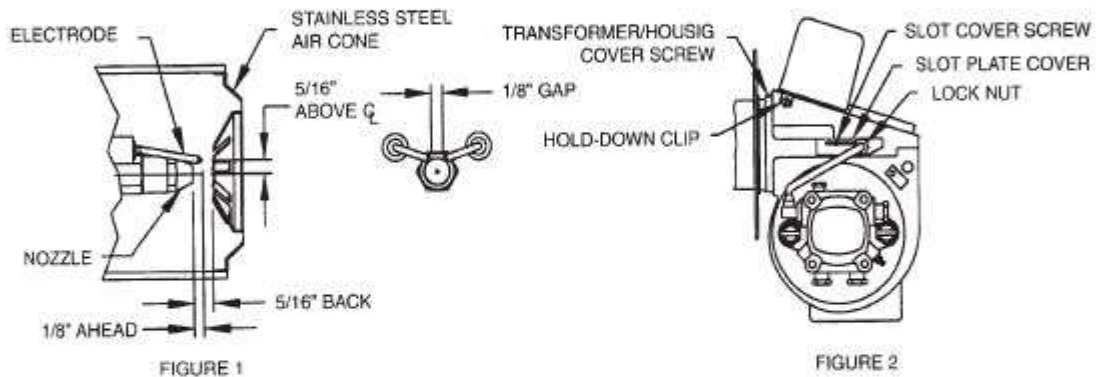

STARTING PROCEDURE

PREPARATION STEPS

1. Calibrate and check operation of combustion analysis equipment, CO₂ (carbon dioxide) or O₂ (oxygen) analyzer, smoke pump tester, fuel gas thermometer and oil pressure/vacuum gages. Follow the manufacture recommendation for proper calibration and check out.
2. Install oil pressure gage and vacuum gage in the outlet pressure and inlet ports of the fuel unit.
3. Set oil burner slotted air band shutter 25% open.

STARTING BURNER

1. Turn off the main power switch to the burner and appliance.
2. Be sure main fuel tank is filled and all manual valves are open between the fuel tank and the burner.
3. Turn on the main power switch to the burner and appliance.
4. Prime the fuel pump per its manufacturers recommendations, check fuel unit for 100 psi delivery pressure and check system vacuum (see paragraphs under Fuel Units and Oil Lines).

CAUTION: Do not run fuel unit dry for more than five minutes or damage to the fuel unit could result.

5. Once the fuel unit is primed (no signs of air in oil bleeder port discharge), close the bleed port. Burner will ignite.
6. When flame is established, make a temporary air adjustment to the slotted air band for a visually clean combustion smoke observed from the appliance vent. Allow the appliance to warm up approximately five minutes or until the water temperature reaches that recommended by the cleaning equipment manufacture.
7. Adjust the slotted air band shutter until a #1 to #2 smoke (Shell Bacharach scale) is obtained at the appliance vent.
8. Check CO₂ (carbon dioxide) and/or O₂ (oxygen) percentages and smoke in the flue gas at the appliance vent. In general, CO₂ readings should be in the 10% to 12% range and O₂ readings in the 7.4% to 4.7% range.
9. Once the desired combustion results are attained, securely tighten slotted air band screw and check that controls on the appliance are adjusted per the cleaning equipment manufactures instruction sheets. Remove oil pressure and vacuum gages from the fuel unit and reinstall pipe plug fittings.
10. Check burner lighting with hot chamber, then allow burner and appliance to sufficiently cool. Then check burner lighting with a cold chamber.



SUGGESTION: all new installations should be reinspected after one or two weeks of normal operation.

MAINTENANCE

OILING MOTOR – The MSR_DC oil burner is provided with a ball bearing shaft motor. Ball-bearing motors do not require oiling under normal service conditions.

FILTER – The oil filter cartridge should be replaced, or sediment cleaned, periodically so the fuel oil will not become contaminated and plug up the fuel pump and nozzle of oil burner.

NOZZLE – The nozzle should be changed at least once each year or twice a year if the cleaning equipment is used daily through the year and should poor combustion occur. Replace with the proper nozzle.

COMPONENTS – If for any reason any of the burner parts have to be replaced, always use parts recommended by the manufacturer. Specify part numbers and description when ordering. (IN ALL COMMUNICATIONS STATE BURNER MODEL AND SIX DIGIT SPECIFICATION NUMBER).

ELECTRODE SETTINGS – This is very important for reliable ignition of the oil; check these once a year in accordance with the instructions provided in this manual. Replace electrodes if worn excessively or if porcelain insulator is oil soaked or cracked (See Figure 1).

FAN & BLOWER HOUSING – This must be kept clean, free of dirt and lint; open transformer to check fan blades from above. Be sure the electric power is off on burner when the transformer is opened up for this inspection. Should the blower wheel be removed for replacement or cleaning, reinstall as shown in figure 3.

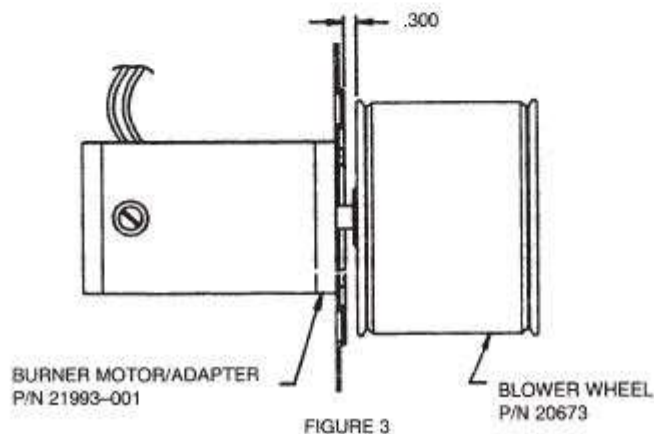



BURNER COMPONENTS - MODEL MSR-DC

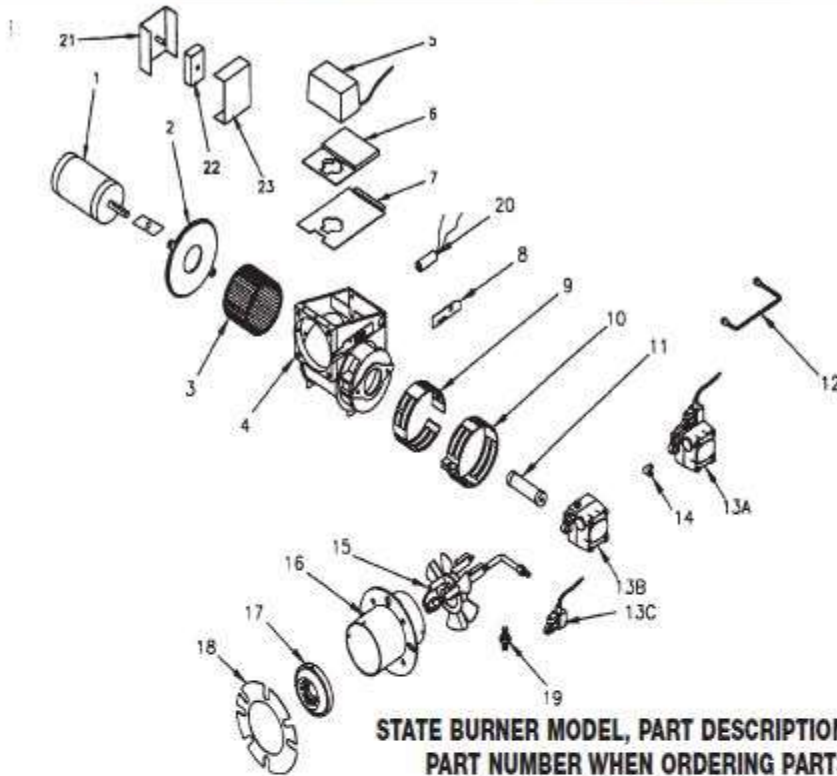

AIR TUBE & GUN ASSEMBLY DETAILS MODEL MSR-DC

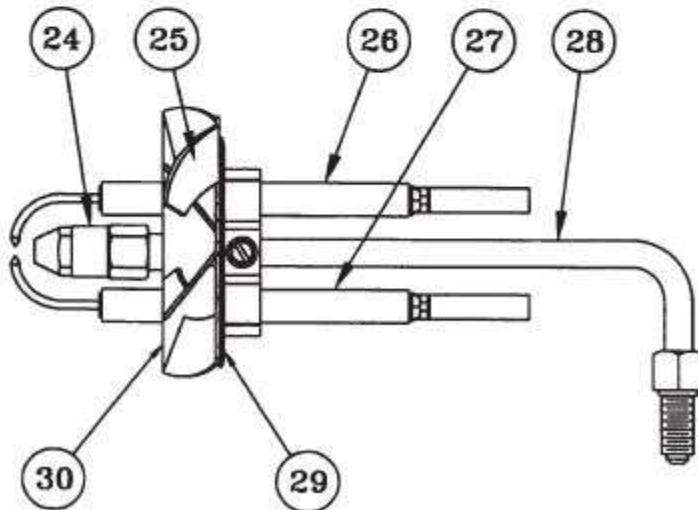

ITEM	QTY	PART #	DESCRIPTION
1	1	8046448-1	MOTOR 1/8 STANDARD
	1		MOTOR 1/8 LOW AMP
2	1	8046448-2	MOTOR ADAPTER
3	1	8046448-3	BLOWER WHEEL 3 1/2 X 4 1/4
4	1	8046448-4	BURNER HOUSING
5	1	8046448-5	IGNITOR - 12VDC
6	1	8046448-6	MOUNTING BASE
7	1	8046448-7	HOUSING COVER
8	1	8046448-8	SLOT COVER PLATE
9	1	8046448-9	INNER AIR BAND
10	1	8046448-10	OUTER AIR BAND
11	1	8046448-11	COUPLING
12	1	8046448-12	OIL LINE ASSEMBLY 6"
	1		OIL LINE ASSEMBLY 8"
13	1	8046448-13A	FUEL UNIT: SUNTEC COMBO
	1	8046448-13B	FUEL UNIT: SUNTEC
	1	8046448-13C	FUEL SOLENOID
14	1	8046448-14	ELBOW (USE WITH 13A)
15	1	8046448-15	GUN ASSEMBLY
16	1	8046448-16	AIR TUBE/FLANGE ASM
17	1	8046448-17	AIR CONE - #3A
	1		AIR CONE - #4A
18	1	8046448-18	GASKET
19	1	8046448-19	CONNECTOR (USE WITH 13B, 13C)
20	1	8046448-20	CAD CELL
21	1	8046448-21	CONTROL BOX
22	1	8046448-22	TIMER, DROP OUT
23	1	8046448-23	COVER, CONTROL BOX
24	1	8046448-24	ADAPTOR, NOZZLE SUPPORT
25	1	8046448-25	ELECTRODE SUPPORT ASM
26	1	8046448-26	ELECTRODE (RH)
27	1	8046448-27	ELECTRODE (LH)
28	1	8046448-28	OIL PIPE/FITTING
29	1	8046448-29	DISC/BAFFLE PLATE
30	1	8046448-30	CAST STABILIZER
	1		STAMPED STABILIZER

Suggested Combustion Chamber Dimensions Conversion or Upgrading Chamber Dimensions (In Inches)					
Firing Rate (G.H.P)	Square		Round	Height	Floor to Nozzle
	Width	Length			
0.85	8.5	8.5	8.5	8.5	8.5
1.00	9	9	10 $\frac{1}{2}$	12 $\frac{1}{2}$	5-6
1.25	10	10	11 $\frac{1}{4}$	12 $\frac{1}{2}$	5-6
1.35	10 $\frac{1}{2}$	10 $\frac{1}{2}$	11 $\frac{1}{2}$	12 $\frac{1}{2}$	5-6
1.50	11	11	12 $\frac{1}{2}$	13	5-6
1.65	11 $\frac{1}{2}$	11 $\frac{1}{2}$	13	13 $\frac{1}{2}$	5-6
2.00	12 $\frac{1}{2}$	12 $\frac{1}{2}$	14 $\frac{1}{2}$	13 $\frac{1}{2}$	6-7
2.50	14 $\frac{1}{2}$	14 $\frac{1}{2}$	16	14	7-8
3.00	15 $\frac{1}{2}$	15 $\frac{1}{2}$	17 $\frac{1}{2}$	15	7-8

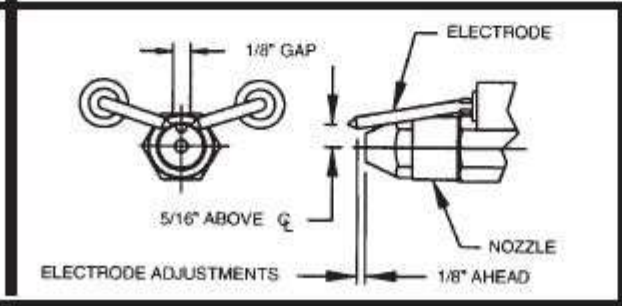
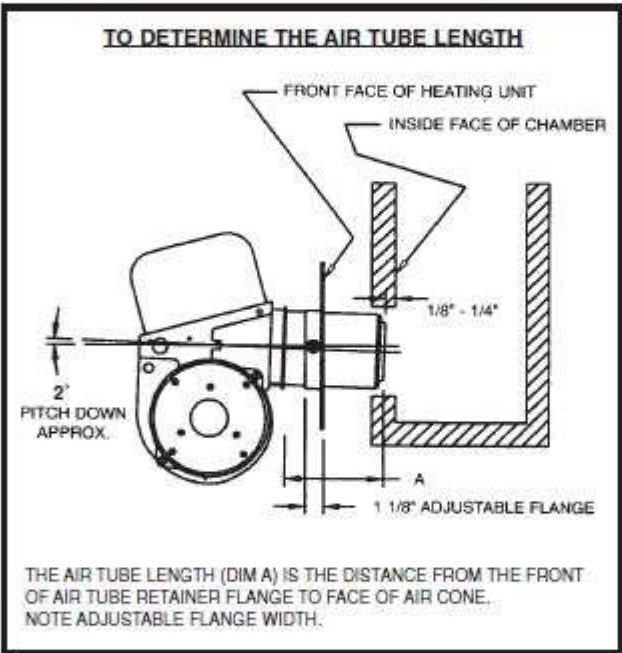

Notes



A series of horizontal lines for writing notes, starting below the title and extending to the bottom of the page.



WAYNE COMBUSTION SYSTEMS

801 GLASGOW AVE.
FORT WAYNE, IN 48803

LIMITED WARRANTIES FOR OIL AND GAS BURNERS, MADE BY WAYNE AND USED IN RESIDENTIAL INSTALLATIONS

WAYNE COMBUSTION SYSTEMS ("WAYNE") warrants to those who purchase its **Oil Burner Models** for resale or for incorporation into a product of resale, that its burner is free from defects in material and workmanship under normal use and service for thirty-six (36) months from the date of manufacture. **ALL GAS BURNERS** manufactured by "WAYNE" will be similarly warranted for eighteen(18) months from date of manufacture except where original manufacture offers a greater warranty. (Reference #6 below) **THESE LIMITED WARRANTIES DO NOT APPLY UNLESS THE BURNER COVERED BY IT IS PROPERLY INSTALLED BY A QUALIFIED, COMPETENT TECHNICIAN, WHO IS LICENSED WHERE STATE AND/OR LOCAL CODES PREVAIL, AND WHO IS EXPERIENCED IN MAKING SUCH INSTALLATIONS. IN ACCORDANCE WITH NFPA #31 OF THE NATIONAL FIRE PROTECTION ASSOCIATION AND IN ACCORDANCE WITH ALL LOCAL, STATE AND NATIONAL CODES.**

Any **IN-WARRANTY** burner component which is defective in material or workmanship will be either repaired or replaced as follows:

1. Fuel units, motors, transformers, gas valves, and controls should be returned to an authorized service station or distributor of WAYNE for determination of applicability of this LIMITED WARRANTY as to either repair or replacement, where said service station or distributor is reasonably available in the customer's locality. The manufacturers of burner components regularly publish and distribute listings showing the locations of their network of service stations. Where such local service is NOT available for the burner components described above or other burner parts are involved, these items should be returned, freight prepaid, to WAYNE Service Department, 801 Glasgow Ave, Fort Wayne, Indiana 46803.
2. Burners and/or component(s) determined to be covered under this LIMITED WARRANTY by WAYNE shall be repaired or replaced at WAYNE's sole option.
3. WAYNE is not responsible for any labor cost for the removal and replacement of said burner or burner components and equipment associated therewith.
4. A burner so repaired will then carry the LIMITED WARRANTY equal to the unexpired portion of the original burner LIMITED WARRANTY.
5. If inspection by WAYNE does **NOT** disclose any defect covered by this LIMITED WARRANTY, the burner or burner component(s) will be either repaired or replaced at the expense of the customer and WAYNE's regular charges will apply.
6. If the original manufacturer of a burner component offers a warranty greater than either of our LIMITED WARRANTIES described above, then this portion will be added to our LIMITED WARRANTY.

This LIMITED WARRANTY does **NOT** cover products which have been damaged as the result of accident, abuse, misuse, neglect, improper installations, improper maintenance or failure to operate in accordance with WAYNE's written instructions.

These LIMITED WARRANTIES do not extend to anyone except the first purchaser at retail and only when the burner is in the original installation site.

IMPLIED WARRANTIES OF MERCHANTABILITY AND FITNESS FOR A PARTICULAR PURPOSE SHALL BE LIMITED TO THE DURATION OF THE LIMITED EXPRESS WARRANTIES CONTAINED HEREIN. WAYNE EXPRESSLY DISCLAIMS AND EXCLUDES ANY LIABILITY FOR CONSEQUENTIAL OR INCIDENTAL DAMAGES OF ANY NATURE FOR BREACH OF ANY EXPRESS OR IMPLIED WARRANTY.

Some states do not allow limitation on how long an implied warranty lasts, so the above limitation may not apply to you. Also, some states do not allow the exclusion or limitation of incidental or consequential damages, so the above limitation or exclusion may not apply to you. WAYNE neither assumes or authorizes any person to assume for WAYNE any other liability or obligation in connection with the sale of these products. This warranty gives you specific legal rights, and you may also have other rights which vary from state to state.

PAGE LEFT BLANK

WARRANTY RETURN GOODS POLICY

LIMITED WARRANTY

The Manufacturer warrants its products to be free from defects in material and workmanship for a period of twelve months from the date of shipment from the factory. The Manufacturer shall not be responsible for any damage resulting to or caused by its products by reason of installation, improper storage, unauthorized service, alteration of the products, neglect or abuse, or use of the product in a manner inconsistent with its design. The warranty does not extend to any component parts not manufactured by Manufacturer; however, Manufacturer's warranty herein shall not limit any warranties made by manufacturers of component parts which extend to Buyer.

Claims for defects in material and workmanship shall be made in writing to Manufacturer within ten days of discovery of defect. Manufacturer may either send a service representative or have the product returned to its factory at Buyer's expense for inspection. Upon notification of defect, Manufacturer will issue a return goods authorization number to Buyer. The return goods authorization number must accompany the product returned. If judged by the Manufacturer to be defective in material or workmanship, the product will be replaced or repaired at the option of the Manufacturer, free from all charges except authorized transportation. Buyer shall be responsible for all maintenance services consisting of lubrication and cleaning of equipment, replacing expandable parts, making minor adjustments, and performing operating checks, all in accordance with procedures outlined in Manufacturer's maintenance literature.

THE FOREGOING WARRANTY IS IN LIEU OF ALL OTHER WARRANTIES AND NO REPRESENTATIONS, GUARANTEES, OR WARRANTIES, EXPRESS OR IMPLIED, (INCLUDING BUT NOT LIMITED TO A WARRANTY OF MERCHANTABILITY OR FITNESS FOR A PARTICULAR PURPOSE), ARE MADE BY THE MANUFACTURER IN CONNECTION WITH THE MANUFACTURE OR SALE OF ITS PRODUCTS. NO EMPLOYEE, DISTRIBUTOR, OR REPRESENTATIVE IS AUTHORIZED TO CHANGE THIS WARRANTY ON BEHALF OF MANUFACTURER.

THE REMEDIES OF BUYER SET FORTH HEREIN ARE EXCLUSIVE AND ARE IN LIEU OF ALL OTHER REMEDIES. THE LIABILITY OF MANUFACTURER WHETHER IN CONTRACT, TORT, UNDER ANY WARRANTY, OR

OTHERWISE SHALL NOT EXTEND BEYOND ITS OBLIGATION TO REPAIR OR REPLACE, AT ITS OPTION ANY PRODUCT OR PART FOUND BY MANUFACTURER TO BE DEFECTIVE IN MATERIAL OR WORKMANSHIP. MANUFACTURER SHALL NOT BE LIABLE FOR COST OF INSTALLATION AND/OR REMOVAL OR BE RESPONSIBLE FOR DIRECT, INDIRECT, SPECIAL OR CONSEQUENTIAL DAMAGES OF ANY NATURE.

GENERAL RETURNS OF MERCHANDISE

1. All returns must be pre-authorized
 - A. Please call our parts department for an RGA number
 - B. Please include RGA number on the outside of box
 - C. Include any required paper work or special instructions
 - D. Items returned without an RGA number will not be accepted
2. All returns are subject to a 20% restock charge.
3. Special items are non-returnable
 - A. Non-stock parts
 - B. Custom parts
 - C. If you are unsure about a parts status when ordering, ask your McLaughlin representative if the item fits on of the above conditions.
4. Items must be returned within thirty days of original order date.
5. Items not returned within 30 days from the date of RGA is issued will not be accepted.
6. The item(s) must be in new condition. Used item(s) are not returnable.

FOR SCHEMATICS SEE: www.mclaughlinunderground

