



McLAUGHLIN[®]

2006 Perimeter Road. Greenville, SC 29605
Toll Free: 800/435-9340 - Phone: 864/277-5870
Fax: 864/235-9661 - Website address: www.mightymole.com
Email address: mmole@mightymole.com

**Parts Manual
Vermeer/ McLaughlin
V1200 AIR/WATER Vacuum Machine
Part #E850507
(SERIAL #12AW081709367 - PRESENT)**

© 2009 by McLaughlin Group, Inc.

051909

All rights reserved. No part of this manual may be reproduced in any form, or by any means without prior written permission of McLaughlin Group, Inc.

Table of Contents

PARTS

SPOIL TANK AND FILTRATION

HYDRAULIC DOOR	4
FILTRATION	6

ENGINE COMPARTMENT

ENCLOSURE	8
ENGINE	10
BLOWER	12
WATER PUMP	16
REGULATOR	20
ELECTRICAL	22
HYDRAULIC PUMP	26
AIR COMPRESSOR	28

WATER TANK AND ACCESSORIES

WATER TANKS - 205 GALLON SADDLE.....	35
ANTIFREEZE	37
HOSE REEL	39

TRAILER AND SKID ASSEMBLY

SKID ASSEMBLY	41
HYDRAULIC JACK OPTION	43
SURGE BREAK OPTION	45

TOOLS

HOSES	47
TOOL RACK	49
REDUCTION TOOL	51
VACUUM TOOL	53
WASH WAND	55
VALVE BOX CLEAN OUT TOOL	57
LAWN SWEEPER	59
SURFACE CLEANER	61

OPTIONS

AUXILLARY HYDRAULICS	63
BOOM	65
HOT BOX	79
ARROW BOARD	81

ELECTRICAL SCHEMATICS

VACUUM DIESEL ENGINE	83
BOOM	89
HOT BOX	92
ARROW BOARD	94

HYDRAULIC SCHEMATICS

TANK AND OPTIONAL JACK	96
BOOM	98

MAINTENANCE MANUALS

ROOTS BLOWER	100
KUBOTA ENGINE	110

WARRANTY	144
----------------	-----

Tank and Door Assembly

V1200

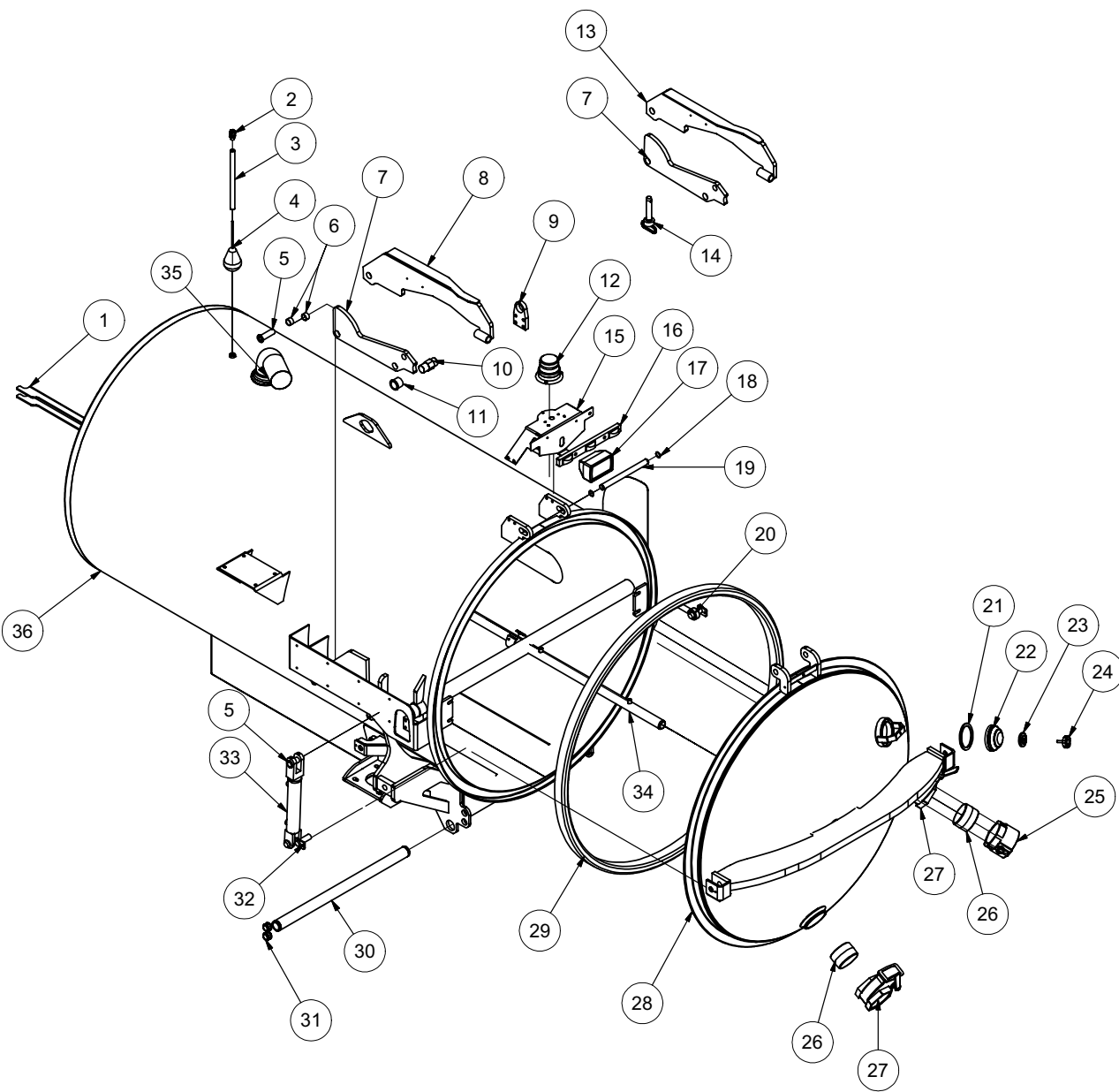

100410-E

VACASSY020

Tank and Door Assembly

V1200

ITEM#	QTY	NUMBER	DESCRIPTION
1	1	8041212	TANK SAFETY BRACE
2	1	X000113	STRAIN RELIEF, 1/2"
3	1	8041471	HIGH LEVEL FLOAT SWITCH TUBE V800
4	1	8030531	HIGH LEVEL FLOAT SWITCH
5	6	8042489	HYD. DOOR - PIN WELDMENT 1"DIA X 3"
6	6	8041524	BUSHING BRONZE 1.25" X 1.00" X .75"LG
7	2	8041604	SHORT LINKAGE WELDMENT
8	1	8041375	DOOR HYD. LONG LINKAGE SS WELDMENT
9	2	8041621	OUTER BEARING PLATE
10	1	8041663	LINKAGE CROSS TUBE WELDMENT
11	2	8041610	BUSHING BRONZE FLANGED 1 1/2"
12	1	8030347	STROBE LIGHT
13	1	8041369	DOOR HYD. LONG LINKAGE WELDMENT
14	1	8041626	HITCH PIN, 1" X 4 1/2"
15	1	8046507	STROBE LIGHT BRACKET
16	1	8041509	LIGHT CLEARANCE 3 BAR
17	1	8031242	WORKLIGHT
18	2	8030362	1" SNAP RING
19	1	8040058	DOOR HINGE ROD
20	2	8041630	ROD END WITH BRONZE BUSHING
21	1	8032007	GASKET, 4" COUPLER
22	1	8031048	SIGHT GLASS
23	1	8031047	SIGHT GLASS PLATE
24	1	8031046	SIGHT GLASS HAND WHEEL
25	1	8030846	4" FEMALE COUPLER
26	2	8030431	4" CLOSE NIPPLE
27	2	8030916	4" GATE VALVE
28	1	8041580	800/1200 HYD LOCK DOOR
29	1	8041767	DOOR SEAL 54"DIA TANK
30	1	8042848	TANK PIVOT ROD
31	4	8041686	GROMMET 1"ID - 1 1/4"DOG - 1/4"WO
32	2	8042171	DOOR CAPTURE PIN
33	2	8041327	HYD. CYLINDER - 8" STROKE
34	1	8041721	TANK ROD WELDMENT - 800 HYD LOCK DOOR
35	1	8040786	EXHAUST ELBOW 4" - WELDMENT
36	1	8043631	1200 TANK - WELDMENT (54")

100410-E

VACASSY020

HD Reverse Flow Filtration

1025

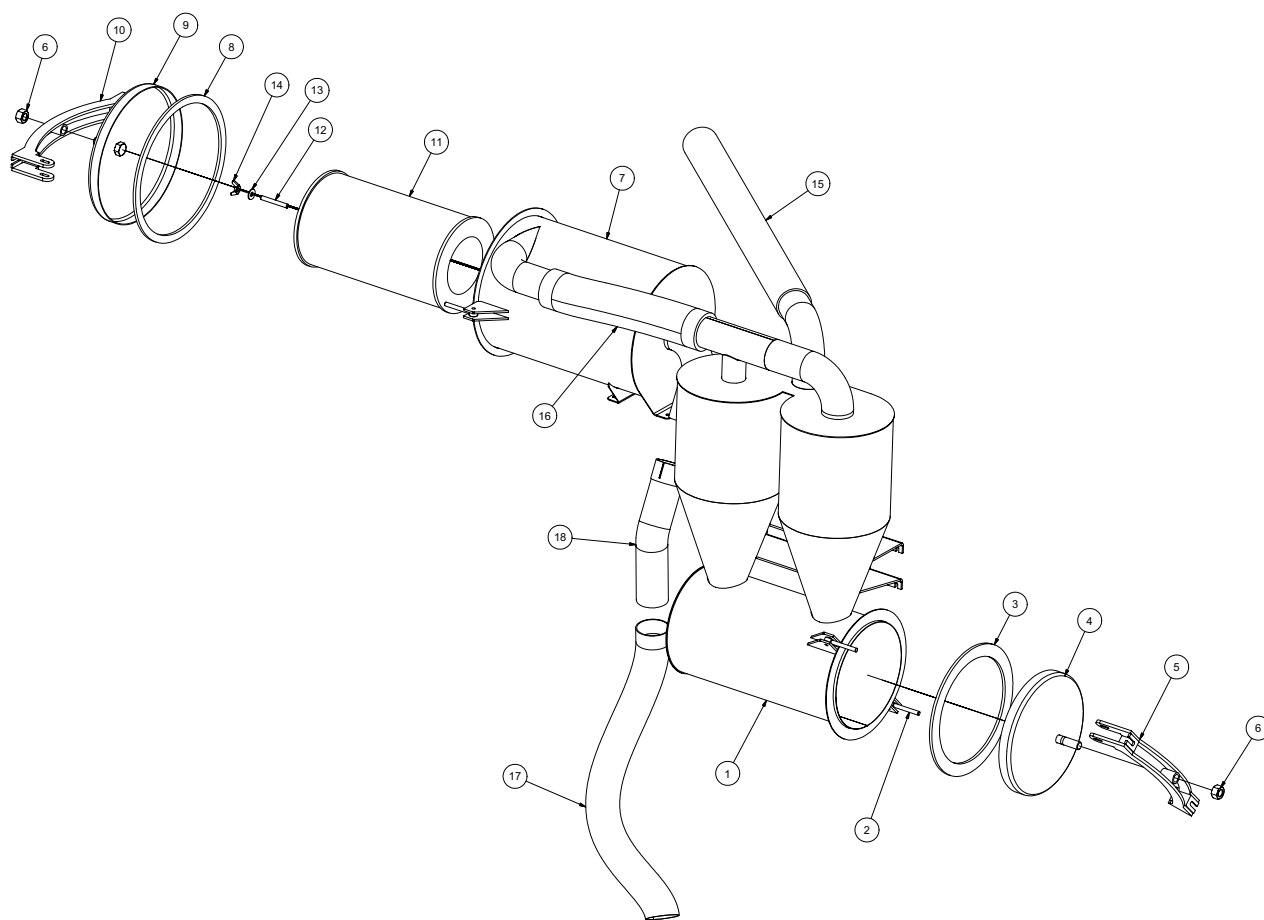

111108

VACASSY363

HD Reverse Flow Filtration

1025

ITEM	QTY	PART #	DESCRIPTION
1	1	8044137	HD CYCLONE SEPERATOR HOUSING - REVERSE FLOW
	2	U000580	SCREW,HC 3/8"-16X3.50
	8	U200600	WASHER,FLAT 3/8"
	2	U210061	NUT,HEX NYLOCK 3/8"-16
2	4	8041593	EYEBOLT 1/2"-13X6.00
	4	8041594	HANDLE, WING 1/2"-13
3	1	8041612	HD CYCLONE SEAL - REVERSE FLOW
4	1	8041402	HD CYCLONE DOME DOOR - REVERSE FLOW
5	1	8041552	HD CYCLONE DOOR LATCH - REVERSE FLOW
	1	U200170	WASHER, FLAT 1"
6	2	U120060	NUT, HEX NYLOCK 1"-8
7	1	8044138	HD AIR FILTER HOUSING - REVERSE FLOW
	2	U000580	SCREW,HC 3/8"-16X3.50
	8	U200600	WASHER,FLAT 3/8"
8	1	8041613	HD AIR FILTER SEAL - REVERSE FLOW
9	1	8041387	HD AIR FILTER DOME DOOR - REVERSE FLOW
10	1	8041554	HD AIR FILTER DOOR LATCH - REVERSE FLOW
	1	U200170	WASHER, FLAT 1"
11	1	8031293	HDAIR FILTER ELEMENT
12	1	8040302	THREADED ROD, AIR FILTER HSG
13	1	U200100	WASHER,FLAT 1/2"
14	1	U130080	NUT, WING 1/2"-13
15	1	8042951	(V500) TANK TO CYCLONE HOSE AG SUCTION 4-58
	1	8044488	(V800) TANK TO CYCLONE HOSE AG SUCTION 4-66
	2	8042606	CLAMP HOSE T-BOLT 450
	1	8042931	CYCLONE TO AIR FILTER HOSE AG SUCTION 4-26
16	2	8042606	CLAMP HOSE T-BOLT 450
	1	8042951	(V500) AIR FILTER TO U-PIPE AG SUCTION 4-58
17	1	8044489	(V500) U-PIPE TO HEADER PIPE AG SUCTION 4-75
	1	8044511	(V800) AIR FILTER TO VACUUM BREAK AG SUCTION 4-36
	1	8041741	(V800) VACUUM BREAK TO HEADER PIPE AG SUCTION 4-72
	4	8042606	CLAMP HOSE T-BOLT 450
	1	8043528	ELBOW 30 DEG 4"ID-OD
18	1	8030400	CLAMP BAND 4"

111108

VACASSY363

Enclosure Assembly

87 HP

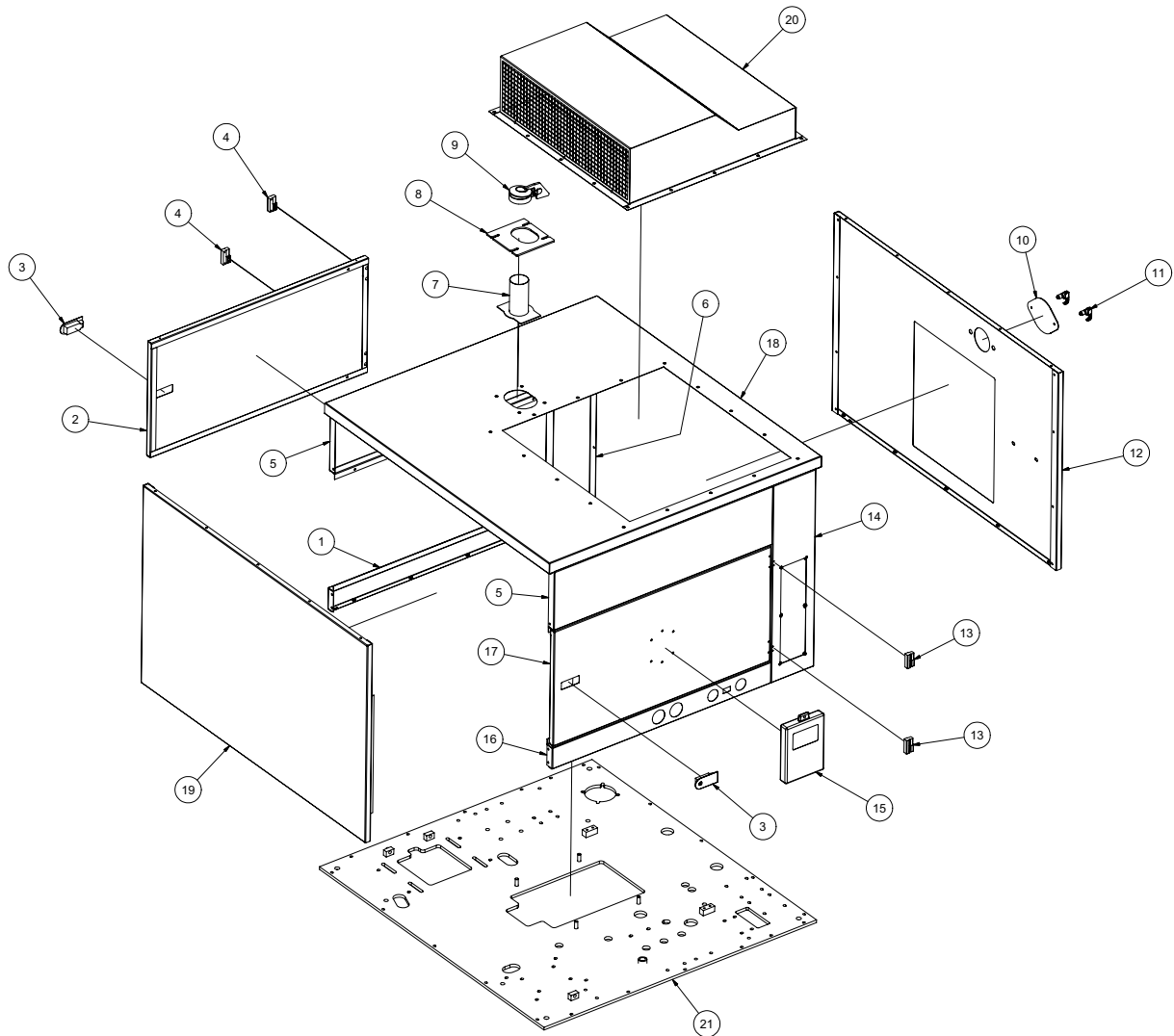

120508

VACASSY411

Enclosure Assembly

87 HP

ITEM	QTY	PART #	DESCRIPTION
1	1	8044254	PANEL SIDE LOWER
2	1	8044258	DOOR PANEL
3	2	8040586	SEALED LEVER LATCH
	1	8041816	KEY DOOR SOUTHCO LATCH
4	2	8040589	OFFSET HINGE TYPE A
	8	U010010	SCREW,HSH #10-32 X 3/8"
5	2	8044257	PANEL SIDE UPPER
6	1	8043922	PANEL SIDE VERTICAL
7	2	8044538	EXHAUST PIPE
8	1	8044541	EXHAUST CLAMP PLATE
9	1	8044537	RAIN CAP 3" SILENT
10	1	8040592	RADIATOR ACCESS COVER
11	2	8040334	SWELL LATCH
	2	U120147	NUT,FLANGED LOCK 5/16-24
12	1	8044551	PANEL FRONT
13	2	8043600	OFFSET HINGE TYPE B
	8	U010010	SCREW,HSH #10-32 X 3/8"
14	1	8043614	PANEL SIDE VERTICAL CONTROL
15	1	E250210	MANUAL BOX
16	1	8044256	PANEL SIDE LOWER FOR GAUGES
17	1	8044260	PANEL DOOR FOR MANUAL BOX
18	1	8044520	PANEL TOP
19	1	8044252	PANEL REAR
20	1	8044523	AIR INLET BOX
21	1	8044242	MAIN PLATE
*	36	U000060	SCREW,HC 1/4-20X1
*	36	U000020	SCREW,HC 1/4-20X1/2
*	128	U200020	WASHER,FLAT 1/4
*	52	U120100	NUT,HEX LOCK 1/4
*	1	8041171	HANDLE
	2	U001017	SCREW,HSH 1/4-20X1.25
	2	U200020	WASHER,FLAT 1/4
	2	U120100	NUT,HEX LOCK 1/4-20
*	2	8041504	DOOR SEAL VERTICAL

* NOT SHOWN

120508

VACASSY411

Engine Kubota V3300T

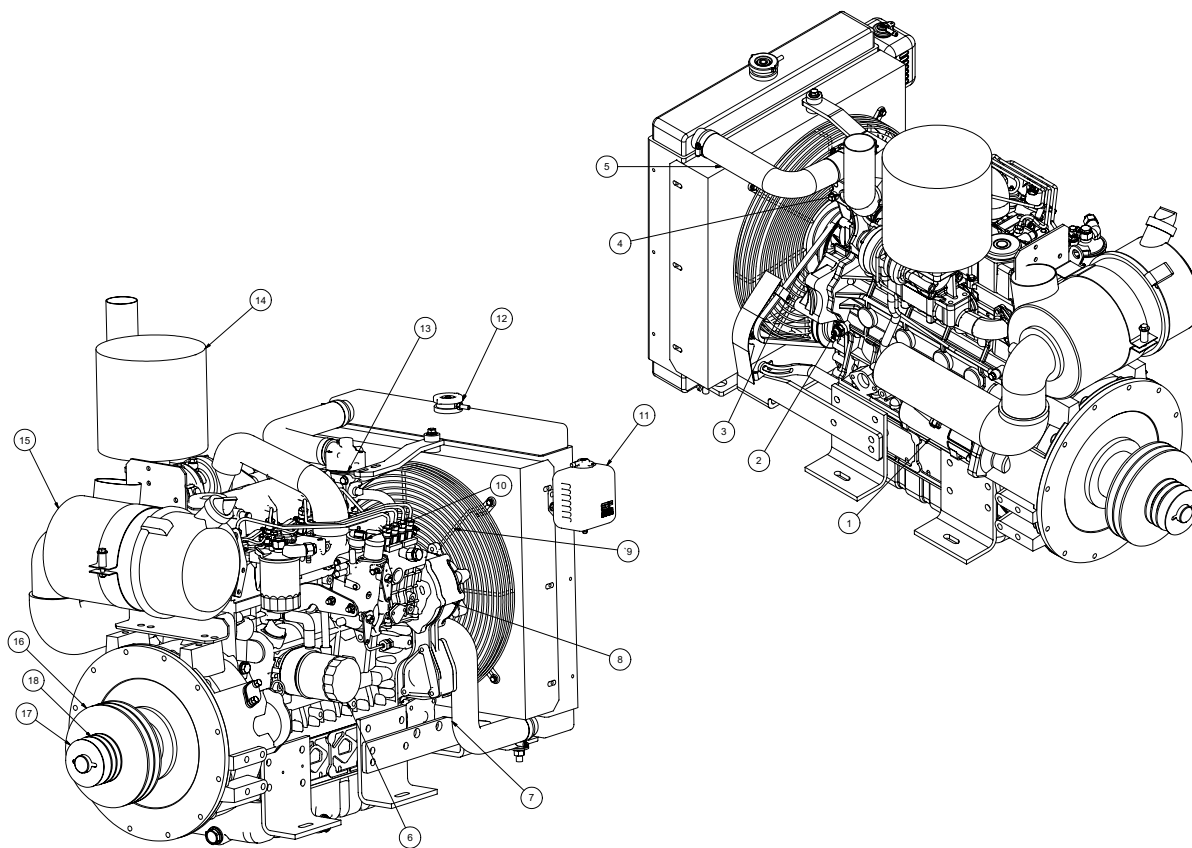

051409

VACASSY854

Engine Kubota V3300T

ITEM	QTY	NUMBER	DESCRIPTION
1	1	1C010-63010	STARTER
2	1	8030960	OIL PRESSURE SWITCH
3	1	1G521-97010	FAN BELT
4	1	8043952	WATER TEMPERTURE SWITCH
5	1	7694	UPPER RADIATOR HOSE
6	1	8032002	OIL FILTER
7	1	fm44	LOWER RADIATOR HOSE
8	1	1C011-64010	ALTERNATOR
9	1	1K011-74110	FAN
10	1	1C010-60015	FUEL SHUTOFF SOLENOID
11	1	19059-72090	OVERFLOW TANK
			OVERFLOW TANK CAP (Sold With Tank)
12	1	31527	RADIATOR CAP
13	1	1C011-73010	THERMOSTAT
14	1	6102484	MUFFLER
15	1	Go8-2526	AIR FILTER HOUSING
*	1	8041055	AIR FILTER ELEMENT (INNER)
*	1	8041054	AIR FILTER ELEMENT (OUTER)
16	1	8044243	SHEAVE, BLOWER 8.35" OD 2517 TL
	1	8042659	BUSHING, TL2517 1 7/16"
17	1	8041799	KEYWAY RETAINER
18	1	8044244	SHEAVE, WATERPUMP 3.95" OD QT 2-GROOVE
	1	8044245	BUSHING, 1 7/16" QT
*	1	8041053	FUEL FILTER
*	1	NA6101050	FUEL PUMP
*	1	T400106	RADIATOR DRAIN FITTING

051409

VACASSY854

Blower Assembly

73HD REV FLOW

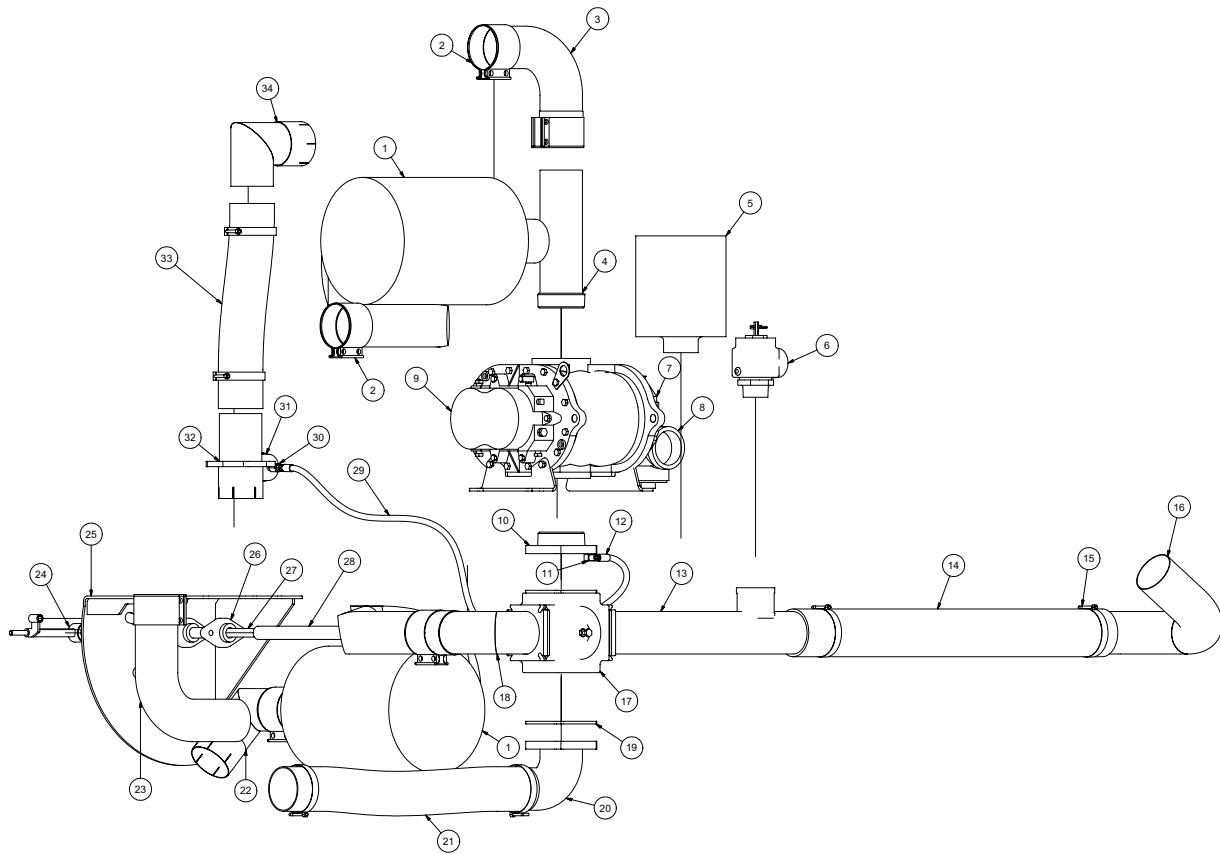

102810-E

VACASSY211

Blower Assembly

73HD REV FLOW

ITEM	QTY	PART NO.	DESCRIPTION
1	2	8030917	SILENCER, 1025 CFM, COWL
2	6	8030400	4" BAND CLAMP
3	1	8040929	4IN ELBOW ID-OD 8"LG
4	1	8045018	4" EXHAUST TUBE ADAPTER WELD'T
5	1	8043553	FILTER AIR 3" 245 CFM
6	1	8041035	PRESSURE RELIEF 1025
7	1	8044515	SHEAVE 7.75 DIA 2 GROOVE
*	1	8040703	SHEAVE 6.15OD SDS 2-GROOVE (OPTIONAL JETTER)
	1	8040485	BUSHING 1 1/8" SDS
	1	U410090	KEY 1/4" X 1/4" X 2 3/4"
	2	8044517	BELT, BX57
8	1	8030866	KUNKLE VALVE, 1025 CFM
9	1	8040001	BLOWER (MODEL 59)
	4	U000817	SCREW, HC 1/2" - 13 X 1"
	4	U210100	WASHER, LOCK 1/2"
	4	U200100	WASHER, FLAT 1/2"
10	1	8044330	REV FLOW 4" HEADER NIP ASSY
11	1	T401100	ELBOW, 4MP - 4MJ 90
12	2	T320030	FITTING, HOSE 4HO - 4FJ
13	1	8044208	REV FLOW SKID HEADER WELD'T
14	1	8044650	HOSE ASSY VAC 4-96 ST-ST
15	6	8042606	CLAMP T-BOLT 4" (450)
16	1	8044451	EXHAUST ELBOW TANK PIVOT 4"
17	1	8041177	4IN 4-WAY VALVE
18	1	8045271	AIR RELEASE ELBOW W/FLANGE
19	4	8043554	GASKET 4-WAY VALVE 4"
20	1	8044636	4' ELBOW 90 OD-FLANGE (3"RAD)
21	1	8043841	HOSE ASSY VAC 4-25 ST-ST
22	1	8044789	AIR RELEASE ELBOW CONNECTOR
23	1	8041814	ELBOW, 4" (4.5"RAD, OD-OD)
24	1	8041617	HANDLE 4"REV FLOW (W/O GRIP) (TRAILER UNIT)
	1	8045404	REV FLOW HANDLE (SKID UNIT)
25	1	8044368	REV FLOW FACEPLATE BRACKET (TRAILER UNIT)
	1	8045405	REV FLOW FACEPLATE BRACKET (SKID UNIT)
26	1	W030080	FLANGE BEARING - 2 BOLT (1"BORE)
27	1	8044365	REV FLOW SHAFT EXT (SHORT) WELD'T
28	1	8044362	REV FLOW SHAFT EXT (LONG) WELD'T
29	1	8044833	HOSE ASSY VAC 4-73 ST-90
30	1	8030483	UNION 4FP-4MJ
31	1	8030372	WATER PRESSURE GAUGE 1/4NPT
32	1	8044766	BRACKET 4" ID - 4"OD W/FLANGE
33	1	8044268	HOSE ASSY VAC 4-22 ST-ST
34	1	8044114	4" ELBOW 90 WELD'T ID-OD

102810-E

VACASSY211

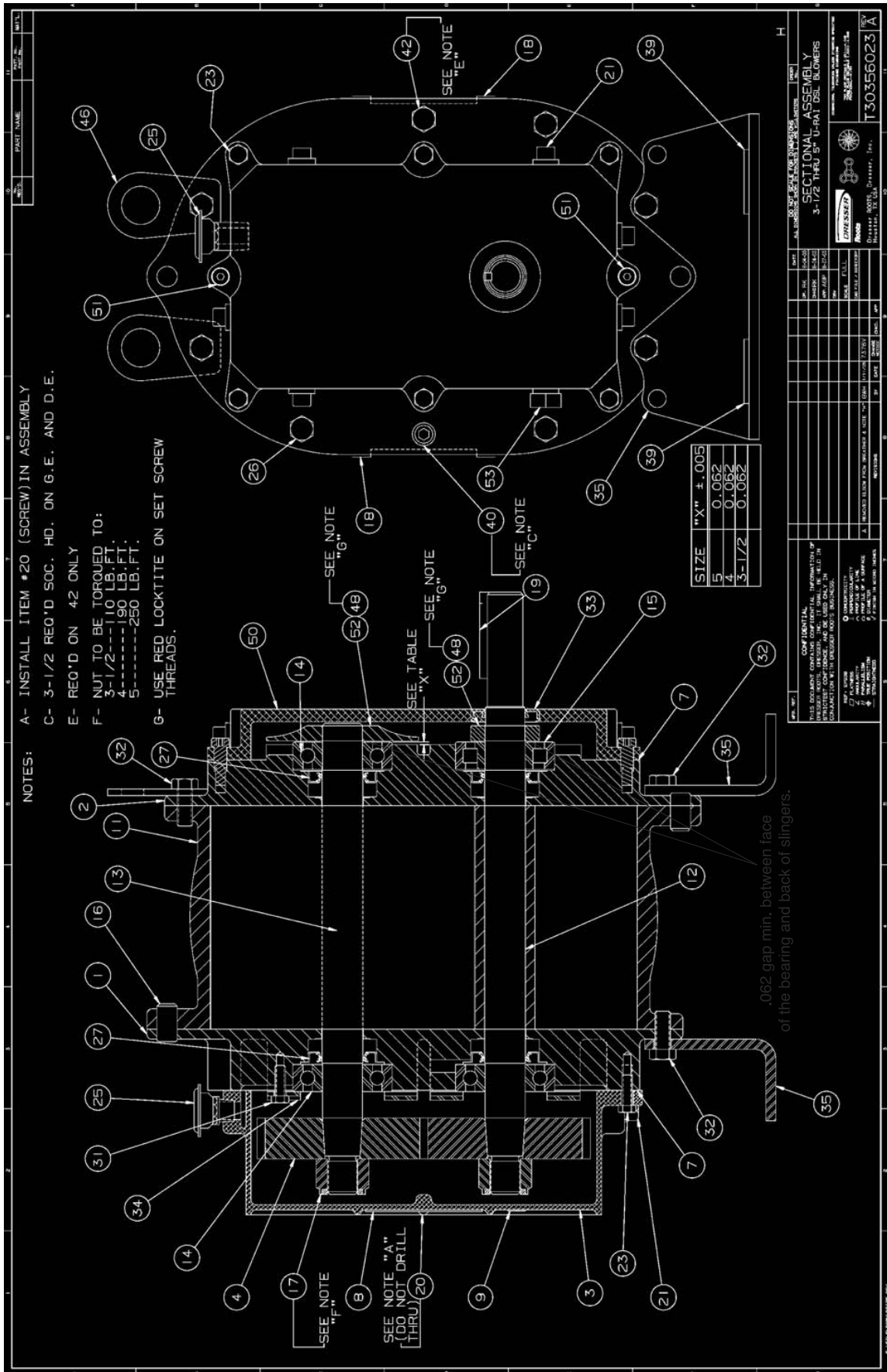

Assembly of URAI DSL Blowers with Splash Lubricated Drive End 3-5" Gear Diameter

**URAI-DSL Splash Lubricated Blowers
4" Gear Diameter**

Item #	Qty	Part #	Description
1	1	8041250-1	Headplate Gear End
2	1	8041250-2	Headplate Drive End
3	1	8041250-3	Gearbox
4	2	8041250-4	Timing Gears
7	1	8041250-7	Gasket, Gear Box, DE Cover
11	1	8041250-11	Cylinder
12	1	8041250-12	Impeller & Shaft Drive
13	1	8041250-13	Impeller & shaft Driven
14	3	8041250-14	Bearing, Ball
15	1	8041250-15	Bearing, Roller
16	4	8041250-16	Pin, Dowel
17	2	8041250-17	Gear Nut
19	1	8041250-19	Key
21	3	8041250-21	Plug, Pipe
23	6	8041250-23	Screw Hex
25	1	8041250-25	Breather (Plug Vent)
26	*	8041250-26	Screw, Hex
27	4	8041250-27	Seal, Lip Bearing
31	4	8041250-31	Screw, Hex, Nylock
32	6	8041250-32	Screw, Hex
33	1	8041250-33	Seal Lip-Drive
34	2	8041250-34	Clamp Plate
35	2	8041250-35	Foot
39	4	8041250-39	Washer Mounting
40	2	8041250-40	Screw Socket
42	2	8041250-42	Screw Hex
48	4	8041250-48	DE Oil Slinger Set Screw
50	1	8041250-50	Drive End Cover
52	2	8041250-52	Drive End Oil Slinger
53	2	8041250-53	Oil Sight Glass

*Quantities vary by blower.

Water Pump Assembly

TS2021

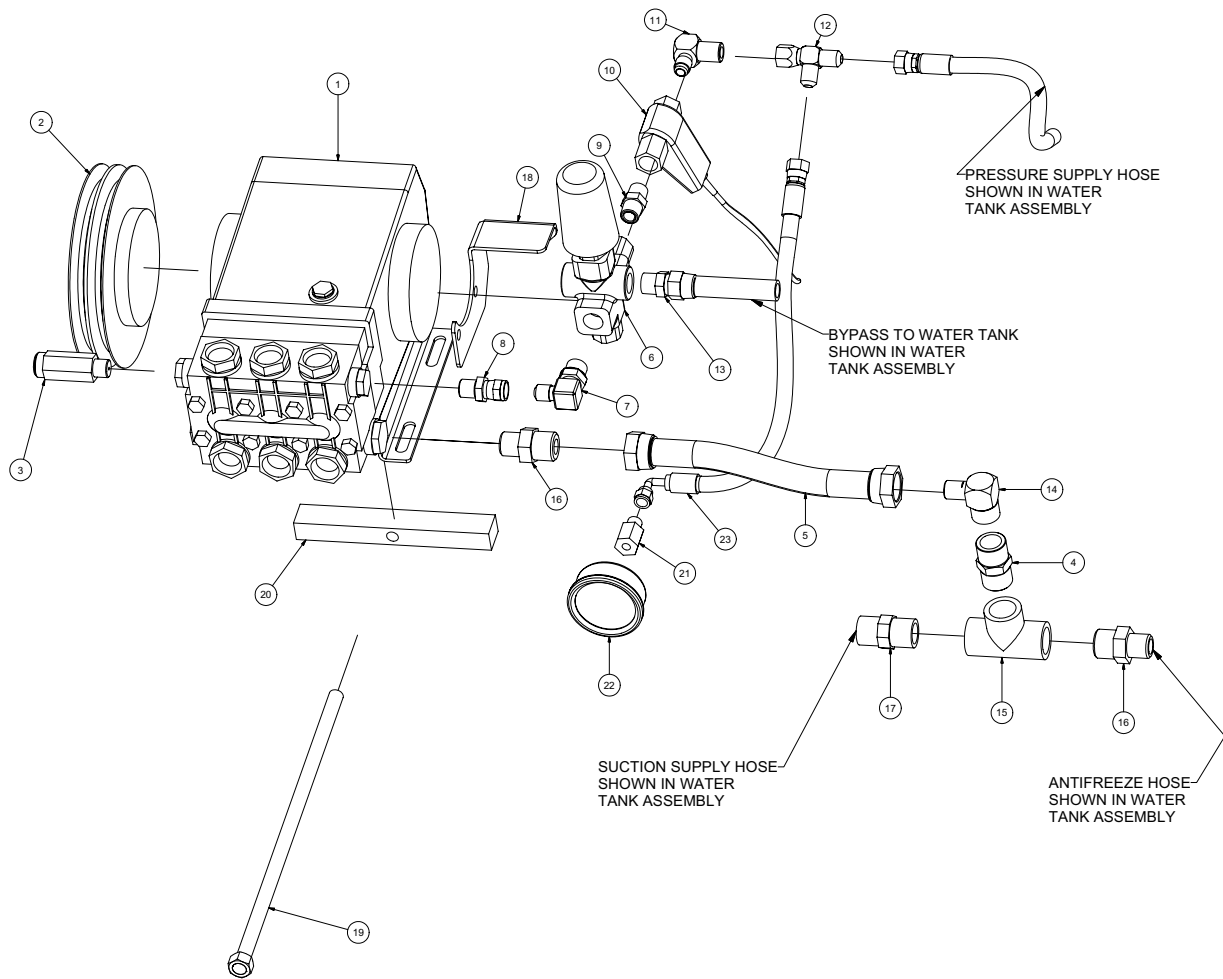

102810-E

VACASSY302

Water Pump Assembly

TS2021

ITEM	QTY	PART NO.	DESCRIPTION
1	1	8031279	WATER PUMP
	4	U000420	SCREW, HC 3/8"-16 X 1"
	4	U210060	WASHER, LOCK 3/8"
	4	U200600	WASHER, FLAT 3/8"
2	1	8030961	WATER PUMP CLUTCH
	1	U410094	KEY 5/16" X 5/16" X 1 3/8"
3	1	8030340	SAFETY RELIEF VALVE 6GPM
4	1	T400080	REDUCER 12MP-8MJ
5	1	8040972	HOSE VAC PUSH 12-8 1/2
	2	8030525	FITTING, HOSE #12FJ PUSH LOCK
6	1	8040177	VALVE, UNLOADER, PULSAR 3
7	1	T401140	ELBOW, 90 1/2"MP-1/2"MJ
8	1	T401125	REDUCER, 3/8MP-1/2FJ
9	1	T400805	UNION, 3/8 MP - 3/8 MP
10	1	8031267	FLOW SWITCH
11	1	T401102	ELBOW, 90 6MJ-6MP
12	1	T402153	TEE 6MJ 6MJ 6FJ
13	1	T400030	REDUCER, 6MP 8MJ
14	1	T401160	ELBOW, 90 3/4 MJ - 1/2 MJ
15	1	T402160	TEE, 3/4FP-3/4FP-3/4FP
16	2	T400080	REDUCER, 12MP 8MJ
17	1	T400100	UNION, 12MP 12MJ
18	1	8043859	WATER PUMP FILTER BRACKET
19	1	8040751	ROD TIGHTENER WELD'T
20	1	8040893	TENSIONER BLOCK, ADJUSTING
21	1	T400110	UNION, 1/4FP-1/4MJ
22	1	8030372	WATER PRESSURE GAUGE 1/4NPT
23	1	8044125	HOSE VAC PUMP TO GAUGE 4-24 ST-90
*	2	8041803	BELT, AX 47 (67/73HP)
	2	8034157	BELT, AX 39 (36HP)
	2	8041082	BELT, AX 48 (99HP COMP 1025 CFM)
	2	8040876	BELT, AX 45 (49HP)

* NOT SHOWN

Water Pump TS2021

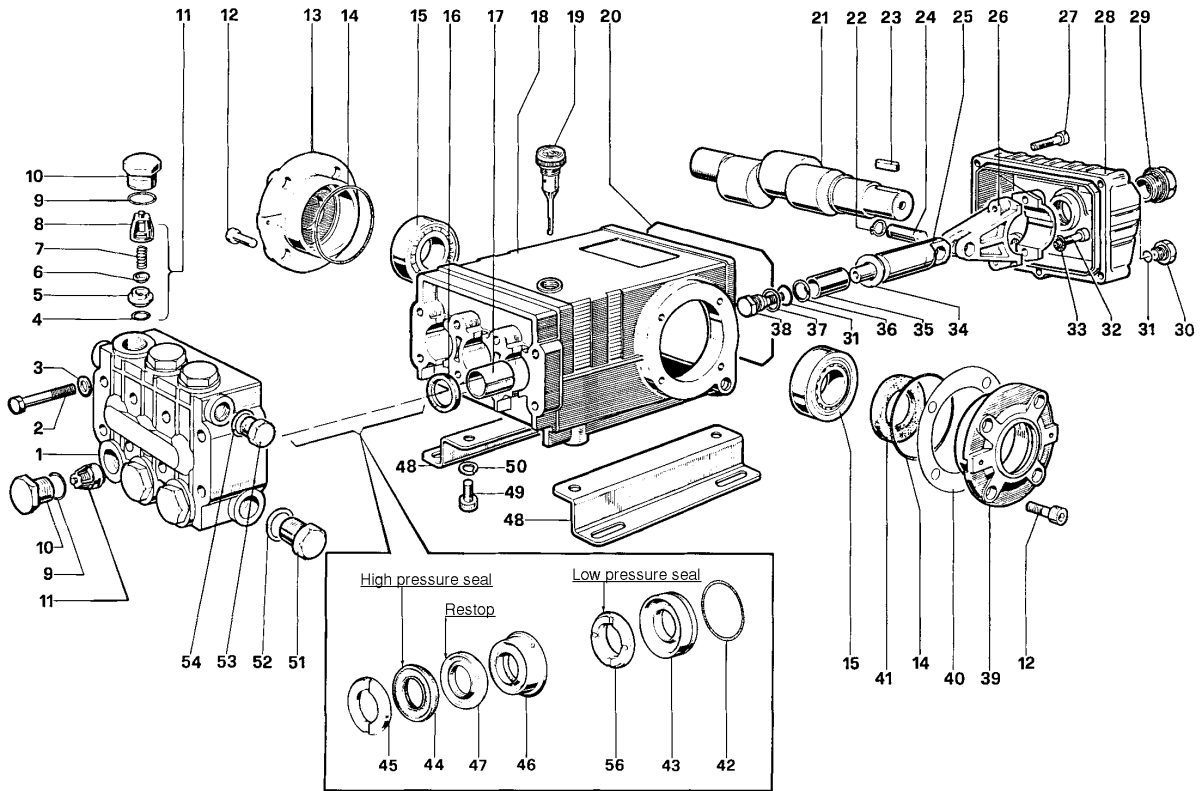

TORQUE SPECS*

*Decrease torque by 20%
if threads are lubricated

Position	Ft. Lbs.	N-M
2	22.1	29.9
10	73.7	99.9
12	14.7	19.2
27	7.3	9.9
29	13.2	17.9
30	14.7	19.2
32	14.7	19.2
38	14.7	19.2
49	29.4	39.8
51	29.4	39.8
53	29.4	39.8

Water Pump TS2021

ITEM	QTY.	PART #	DESCRIPTION	KIT #	ITEM #'S INCL'D IN KIT	NO. OF ASSY IN KIT	NO. OF CYL KIT WILL SERVICE
1	1	8031280-1	Manifold	8031280-KIT1	4, 5, 6, 7, 8 (11)	6	3
2	8	8031280-2	Screw, M8 x 70	8031280-KIT2	16	3	3
3	8	8031280-3	Washer, M8 x 4	8031280-KIT3	41	2	0
4	8	8031280-4	O-ring, .674 x .103	8031280-KIT4	9, 10	6	3
5	6	8031280-5	Seat, Valve	8031280-KIT5	9, 10	6	3
6	6	8031280-6	Plate, Valve	8031280-KIT6	31, 34	3	3
7	6	8031280-7	Spring		36, 37, 38		
8	6	8031280-8	Guide, Valve	8031280-KIT7	45	6	3
9	6	8031280-9	O-ring,.797x.103	8031280-KIT10	42, 43	3	3
10	6	8031280-10	Cap	8031280-KIT28	42, 43, 44,	1	1
11	6	8031280-11	Valve Assembly		45, 45, 47, 56		
12	8	8031280-12	Screw, M8 x 16	8031280-KIT69	44, 47, 56	3	3
13	1	8031280-13	Cover, Crankcase	8031280-KIT71	46, 47	3	3
14	2	8031280-14	O-ring, 2.675 x .103				
15	2	8031280-15	Bearing, Roller				
16	3	8031280-16	Seal, Oil				
17	3	8031280-17	Bushing				
18	1	8031280-18	Crankcase				
19	1	8031280-19	Oil Dip Stick				
20	1	8031280-20	O-ring, Cover				
21	1	8031280-21	Crankshaft				
22	6	8031280-22	Ring, Snap				
23	1	8031280-23	Key				
24	3	8031280-24	Pin, Wrist				
25	3	8031280-25	Guide, Plunger				
26	3	8031280-26	Rod, Connecting				
27	5	8031280-27	Screw, M6 x 30				
28	1	8031280-28	Cover, Crankcase				
29	6	8031280-29	Oil Indicator				
30	1	8031280-30	Cap				
31	4	8031280-31	O-ring,.426x.070				
32	6	8031280-32	Screw, M8 x 35				
33	6	8031280-33	Washer, M8.4				
34	3	8031280-34	Washer, M14				
35	3	8031280-35	Plunger (20 mm)				
37	3	8031280-37	Washer				
38	3	8031280-38	Screw, Plunger				
39	1	8031280-39	Cover, Crankcase				
40	2	8031280-40	Shim				
41	1	8031280-41	Seal, Oil				
42	3	8031280-42	O-ring, 1.364x.070				
43	3	8031280-43	Retainer, Packing				
44	3	8031280-44	Packing				
45	3	8031280-45	Ring, Head, M20				
46	3	8031280-46	Intermed. Ring				
47	3	8031280-47	Testop Ring				
48	2	8031280-48	Pump Feet				
49	4	8031280-49	Screw, M10 x 18				
50	4	8031280-50	Washer, M10.2				
51	1	8031280-51	Cap				
52	1	8031280-52	Washer, M21.5				
53	1	8031280-53	Cap				
54	1	8031280-54	Washer, M17.5				
56	3	8031280-56	Seal,Low Press,20mm				

072908

VACASSY325

Unloader Valve YU2140

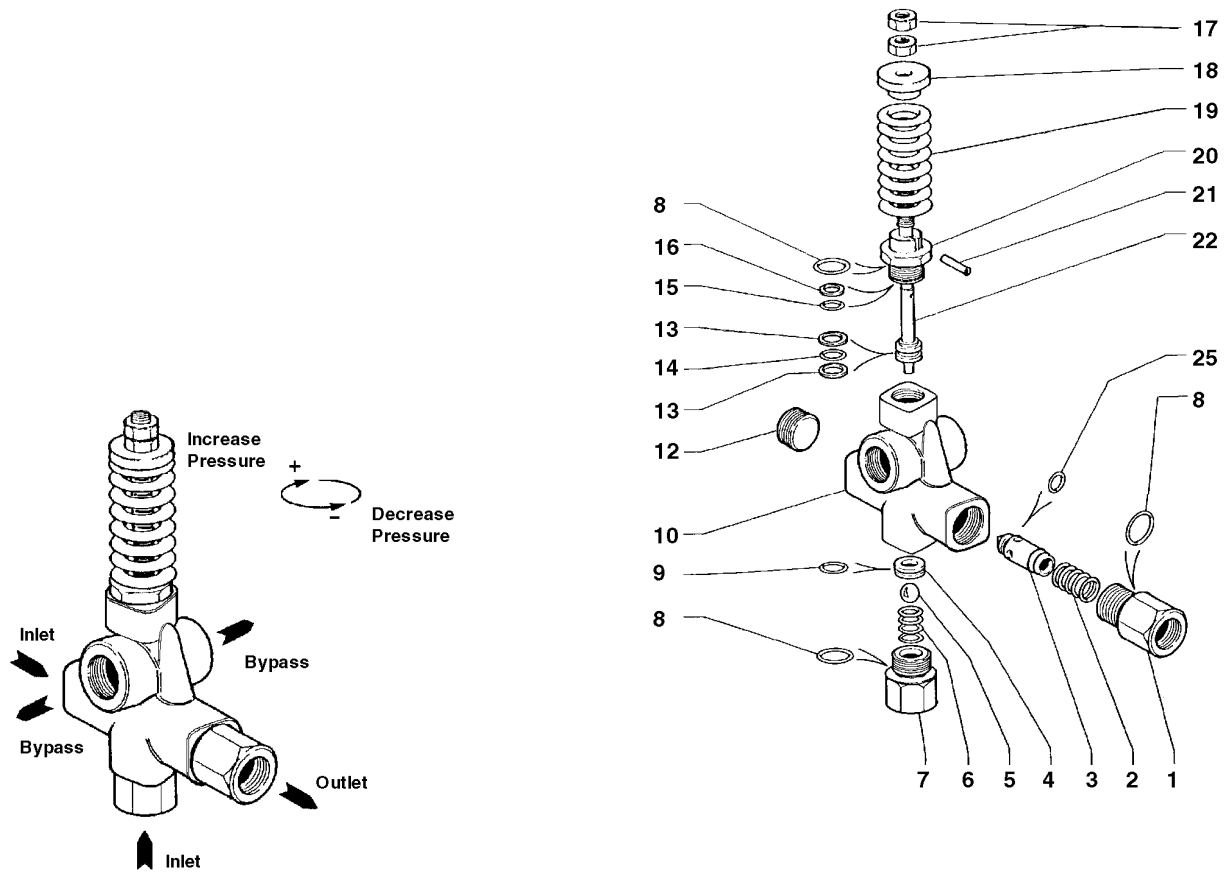

072908

VACASSY326

Unloader Valve YU2140

ITEM	QTY	PART #	DESCRIPTION
1	1	8030341-1	OUTLET CONNECTION
2	1	8030341-2	SPRING
3	1	8030341-3	CHECK VALVE
4	1	8030341-4	SEAT
5	1	8030341-5	SS BALL
6	1	8030341-6	SPRING
7	1	8030341-7	INLET CONNECTION
8	2	8030341-8	O-RING
9	1	8030341-9	O-RING
10	1	8030341-10	VALVE HOUSING
12	1	8030341-12	PLUG
13	2	8030341-13	BACK RING
14	1	8030341-14	O-RING
15	1	8030341-15	O-RING
16	1	8030341-16	BACK RING
17	1	8030341-17	NUT
18	1	8030341-18	SPRING GUIDE
19	1	8030341-19	SPRING-GREEN (YU2140)
20	1	8030341-20	PISTON HOUSING
21	1	8030341-21	PIN
22	1	8030341-22	PISTON
25	1	8030341-25	O-RING

Electrical Control Bracket

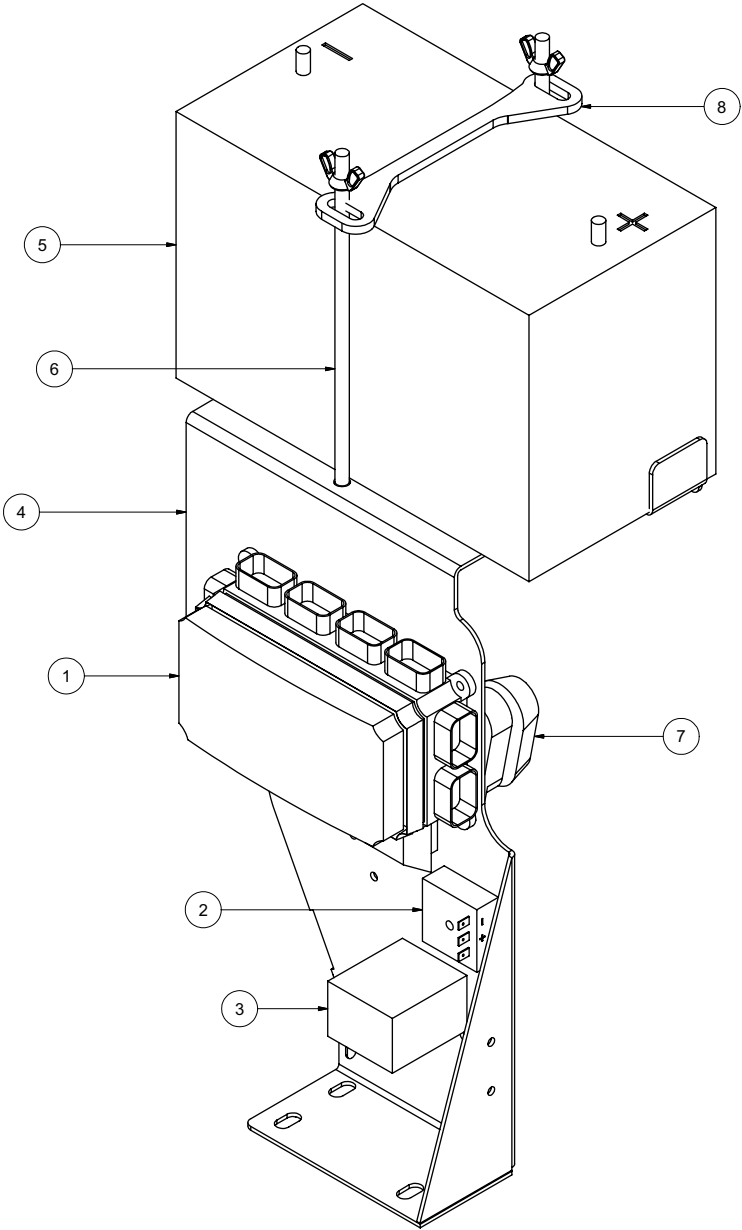

071808

VACASSY550

Electrical Control Bracket

ITEM	QTY	PART NO.	DESCRIPTION
1	1	X000213	BUSSMAN VEC
	7	X000205	FUSE 5A
	2	X000206	FUSE 10A
	2	X000207	FUSE 20A
	3	X000237	FUSE 30A
	1	X000236	CIRCUIT BREAKER 20A
	1	X000210	CIRCUIT BREAKER 30A
	6	X000209	RELAY 35A/25A
	5	X000208	DIODE 6A
2	1	8042282	SWITCH, DELAY RELAY
3	1	X000240	RELAY TIME 30 SECOND
4	1	8043127	CONTROL PANEL - HARNESS MTG PLATE
5	1	X400050	BATTERY, 31-MHD WORKAHOLIC
6	2	8043742	BATTERY HOLD DOWN ROD ASSY
7	1	8043800	FUSE HOLDER AMG
	1	8043801	FUSE 250A AMG
8	1	8050016	BATTERY HOLD DOWN
*	1	X200005	HARNESS VAC CONTROL
*	1	X300222	BATTERY GROUND CABLE
*	1	X300219	BATTERY HOT CABLE 18"
*	1	X300220	ENGINE TO FUSE HOT 1GA 60"
*	1	X300221	HYD PUMP TO FUSE HOT 1GA 36"
*	1	X300221	ELEC CONTROL BOX TO FUSE HOT 1GA 36"
*	1	X300222	ELEC CONTROL BOX GROUND 1GA 18"
*	1	X300224	ENGINE GROUND 1GA 21"
*	1	X300225	HYD PUMP GROUND 1GA 24"

* NOT SHOWN

071808

VACASSY550

Control Panel

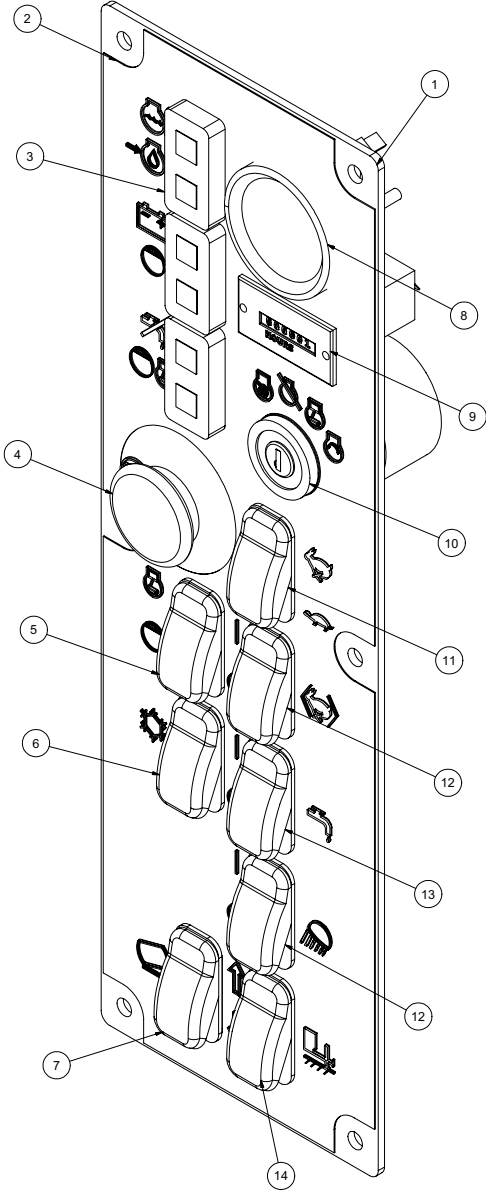
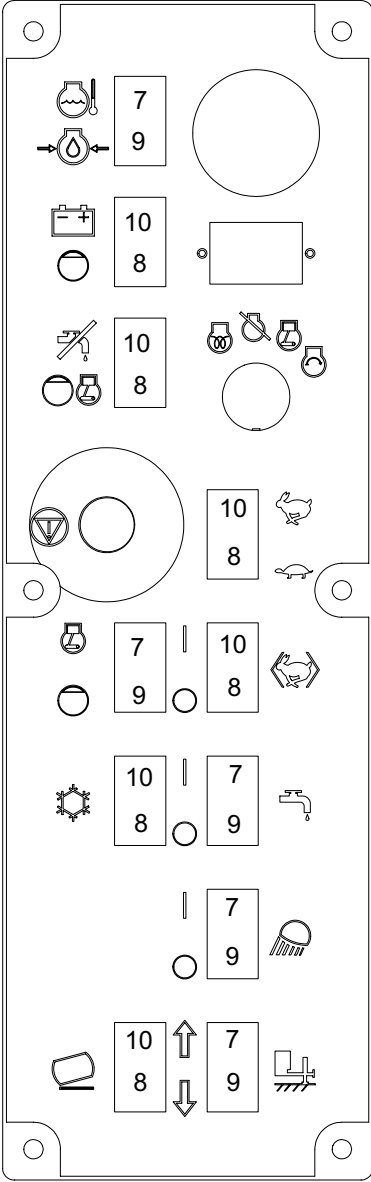

Control Panel

ITEM	QTY	PART NO.	DESCRIPTION
1	1	8043128	CONTROL PANEL - MAIN PLATE
2	1	J200031	DECAL - CONTROL PANEL
3	3	X000260	LIGHT LED DUAL PANEL
4	1	X000280	E-STOP
5	1	X000273	ROCKER SWITCH SPST (ON) NONE -OFF
6	1	X000272	ROCKER SWITCH DPST (ON) NONE -ON
7	1	X000274	ROCKER SWITCH DPDT (ON) OFF (ON)
8	1	X100001	FUEL GAUGE
9	1	X000300	HOUR METER
10	1	8030458	IGNITION SWITCH
11	1	X000271	ROCKER SWITCH DPST ON - ON
12	2	X000270	ROCKER SWITCH SPST ON -OFF
13	1	X000270	ROCKER SWITCH SPST ON -OFF
	1	X000271	ROCKER SWITCH DPST ON -ON
14	1	X000290	ROCKER SWITCH PLUG
	1	X000274	ROCKER SWITCH DPDT (HYD. JACK OPTION)
*	1	8030829	KEY, IGNITION - KUBOTA

* NOT SHOWN

Hydraulic Pump w/ Bracket

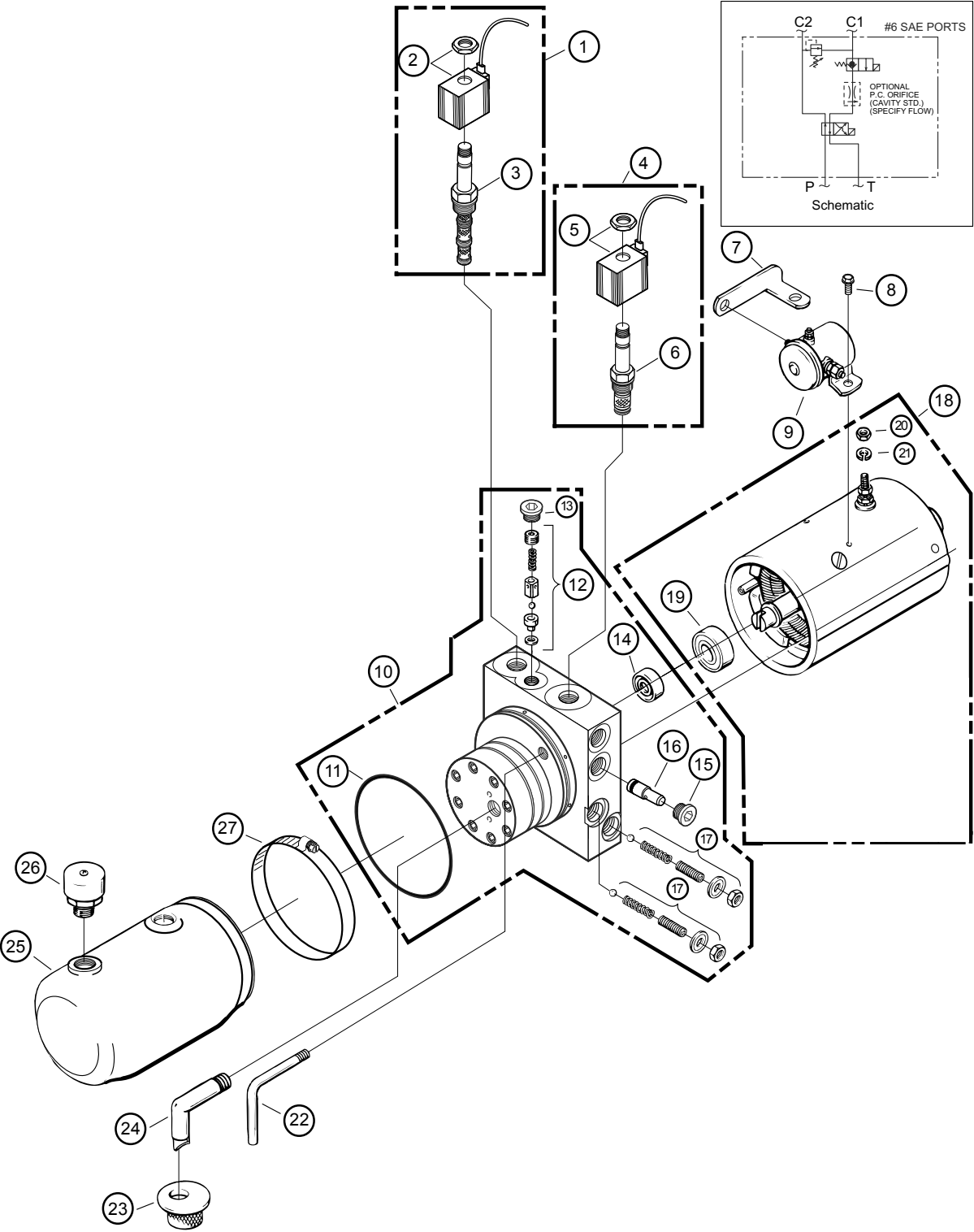

091709-E

VACASSY250

Hydraulic Pump w/ Bracket

ITEM	QTY	NUMBER	DESCRIPTION
	1	8040486	HYDRAULIC PUMP 12V 3QT
		8045355	HYDRAULIC PUMP 12V 6QT (HYDRAULIC DOOR OPTION)
	2	U000420	SCREW, HC 3/8"-16 X 1
	2	U210060	WASHER, LOCK 3/8"
	2	U200600	WASHER, FLAT 3/8"
	2	T400037	UNION 6MB-6MJR
	2	8040973	HOSE ASSY VAC 6-20 ST-90
	2	T400391	BULKHEAD 6MP 6MP
1	1	8041601-14	VALVE, 4 WAY - 2 POSITION (12V)
2	1	8041601-15	COIL, 10 VDC GROUNDED W/DEUTSCH CONN
3	1	8041601-16	CARTRIDGE, 4 WAY - 2 POSITION
4	1	8041601-17	VALVE, 2 WAY - 2 POSITION (12V) GROUNDED
5	1	8041601-18	COIL, 10 VDC, 2 WAY-2 POS GRND W/DEUTSCH CONN
6	1	8041601-19	VALVE 12V HYD 2 WAY-2 POS
7	1	8041601-20	STRAP, MOTOR SOLENOID CONNECTING
8	2	8041601-21	SCREW, RND HD MACH 10-32 X 1/4"
9	1	8041601-22	SWITCH, SOLENOID 12VDC, 3 POST GRND
10	1	8041601-23	PUMP ASSY
11	1	8041601-24	O-RING INDUST 3-5/8 X 3-7/8 X 1/8
12	1	8041601-25	PARTS KIT-VALVE ASSY, POPPET/BALL CHECK
13	1	8041601-26	PLUG
14	1	8041601-27	SEAL
15	1	8041601-28	PLUG, #8 SAE
16	1	8041601-29	VALVE, PRESS, COMP ORIFICE
17	2	8041601-30	PARTS KIT, RELIEF VALVE
18	1	8041601-31	MOTOR, ELECTRIC 12 VDC
19	1	8041601-32	BEARING, BASE, MOTOR
20	1	8041601-33	NUT, HEX 5/16-24
21	1	8041601-34	WASHER, LOCK 5/16"
	2	8041601-38	SCREW, HEX HEAD, 1/4-20 X 1-3/8"
	1	8041601-41	PLUG, 3/8" NPTF
22	1	8041601-42	TUBE, RETURN (1/8")
23	1	8041601-43	SCREEN, FILTER (SUCTION)
24	1	8041601-44	TUBE, FILTER SUCTION 3/8 NPT 90 DEG
25	1	8041601-45	6QT RESEVOIR POLY
	*	8040486-45	3QT RESEVOIR POLY
	*	8041601-48	4.5QT RESEVOIR POLY
26	1	8041601-46	PLUG, VENT, 3/8" NPT
27	1	8041601-47	CLAMP, HOSE WORM GEAR (IN SERIES)
*	1	X200002	HYDRAULIC PUMP WIRE HARNESS
*	1	8043499	HYDRAULIC PUMP MOUNT
		8044297	HYDRAULIC PUMP MOUNT (REVERSE FLOW)
		8045336	HYDRAULIC PUMP MOUNT (412 BLOWER)

* NOT SHOWN

Compressor Assembly

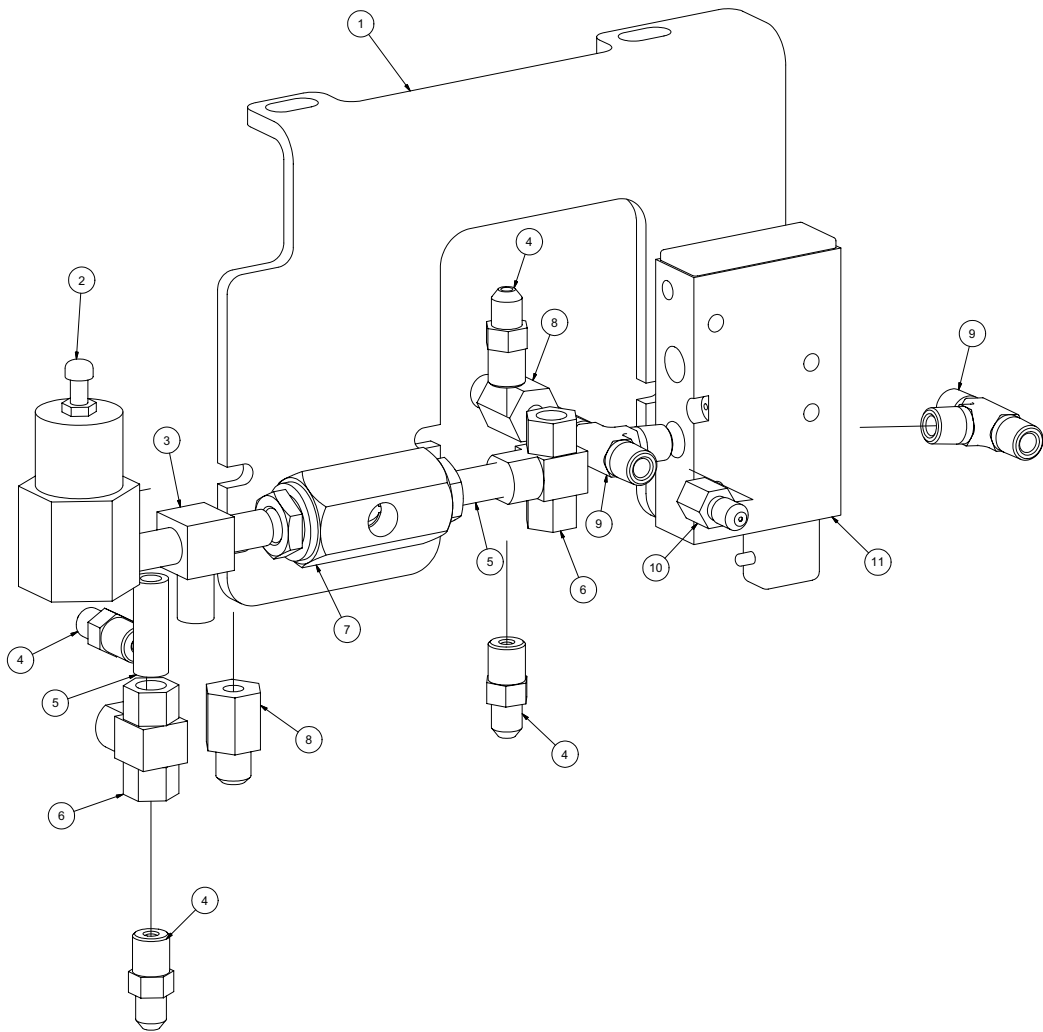

101210-E

VACASSY221

Compressor Assembly

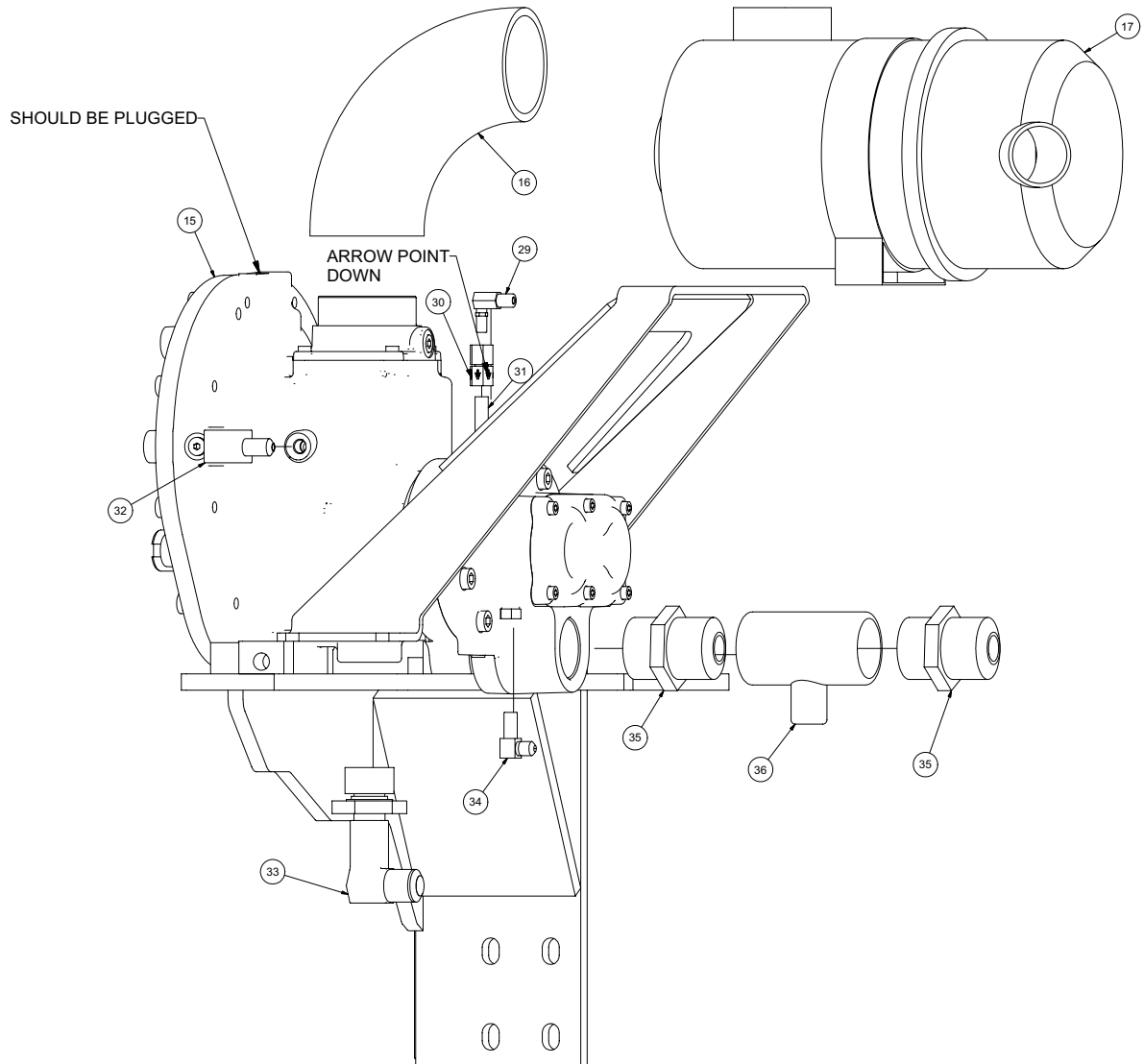

Compressor Assembly

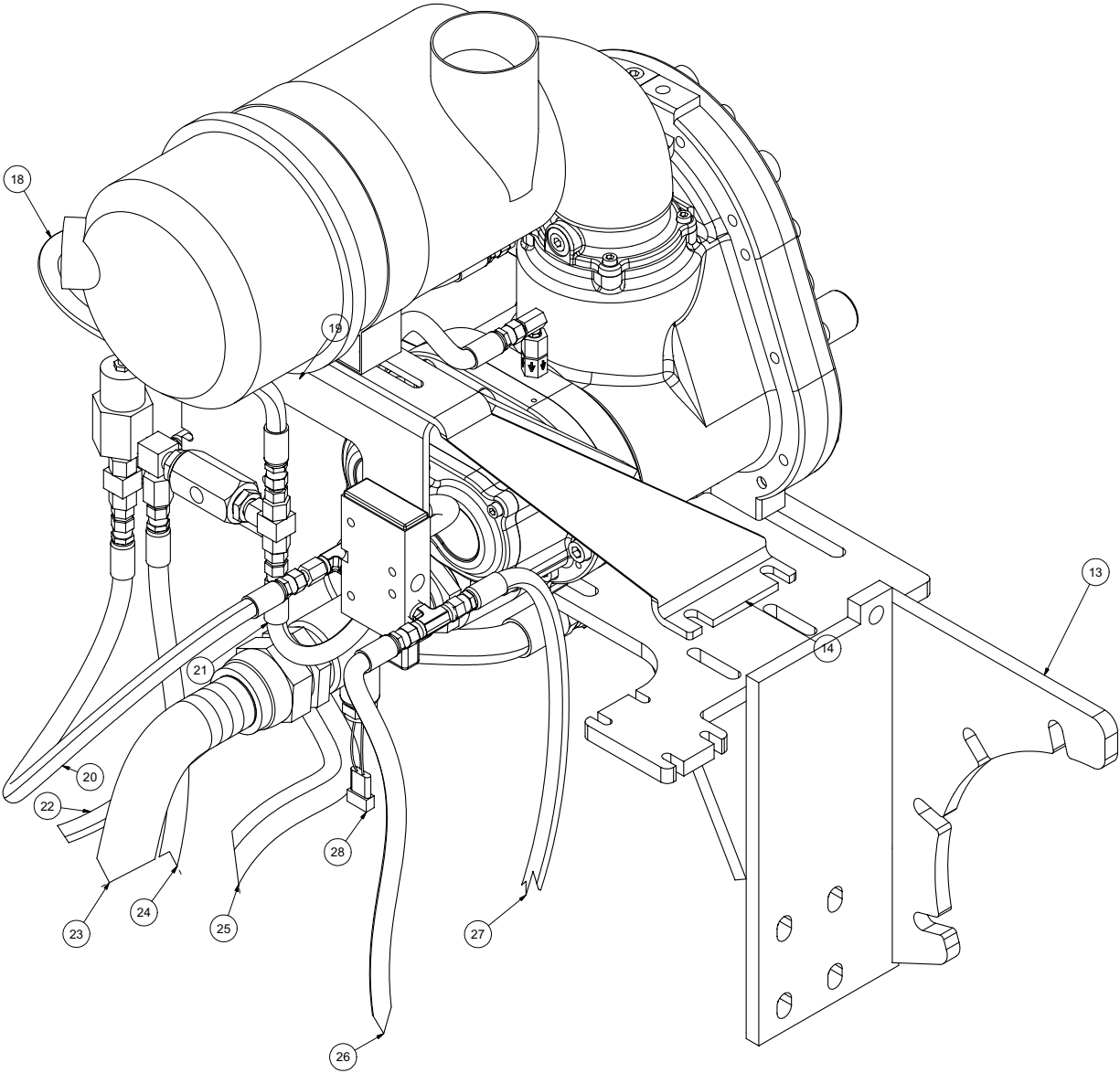

101210-E

VACASSY221

Compressor Assembly

ITEM	QTY	PART NO.	DESCRIPTION
1	1	8044503	BRACKET AIR COMPRESSOR REGULATOR BLOWOFF AND BYPASS SOL
2	1	8044569	VALVE REGULATOR COMPRESSOR
3	1	T402034	TEE, 1/4MP 1/4MP 1/4MP
4	4	T400020	UNION 4MJ - 4MP
5	2	T421010	NIPPLE, CLOSE 1/4MP
6	2	8044667	VALVE SHUTTLE 1/4FP 1/4FP 1/4FP
7	1	8044570	VALVE BLOWDOWN COMPRESSOR
8	2	T400110	UNION 4FP - 4MJ
9	2	T402038	TEE, 4MJ 4MJ 4MP
10	1	8044544	ORIFICE 4MJ -4FJ .062"
11	1	8046883	VALVE SOLENOID AIR 3-WAY PARKER
13	1	8044286	COMPRESSOR MOUNTING BRACKET
14	1	8044457	COMPRESSOR AIR FILTER BRACKET
15	1	8044743	COMPRESSOR (POWERTECH MODEL)
16	1	8043047	ELBOW RUBBER COMPRESSOR INTAKE
17	1	8043049	COMPRESSOR AIR FILTER HSG
	1	8042977	FILTER, AIR ELEMENT
18	1	8044747	HOSE ASSY VAC 4-13" ST-ST
19	1	8044748	HOSE ASSY VAC 4-13" ST-90
20	1	8044745	HOSE ASSY VAC 4-20" ST-90
21	1	8044746	HOSE ASSY VAC 4-10" ST-90
22	1	8043841	HOSE ASSY VAC 4-25" ST-ST
23	1	8044750	HOSE ASSY VAC 1 1/2-25" ST-ST
24	1	8044744	HOSE ASSY VAC 4-76" ST-ST
25	1	8044761	HOSE ASSY VAC 12-24" ST-ST
26	1	8046730	HOSE ASSY VAC 4-33" ST-ST
27	1	8044749	HOSE ASSY VAC 4-23 1/2" ST-90
28	1	8045132	SWITCH TEMP OIL COMP 165F
29	1	T401095	ELBOW, 90 1/8"MP - 1/4" MJ
30	1	8044264	VALVE, INLINE CHECK 1/8P
31	1	T421008	1/8" CLOSE NIPPLE
32	1	T401230	ELBOW, 90 1/4" MB X 1/4" MJ
33	1	T401341	ELBOW, 3/4MB - 3/4MJ
34	1	8044263	ELBOW, 1/8MP X 1/4MJ W/CHECK AND ORIFICE
35	2	T400582	UNION, 1 1/2MP - 1 1/2MB
36	1	T402219	TEE, 1 1/2FP - 1/2FP - 1 1/2FP

Compressor Tank Assembly

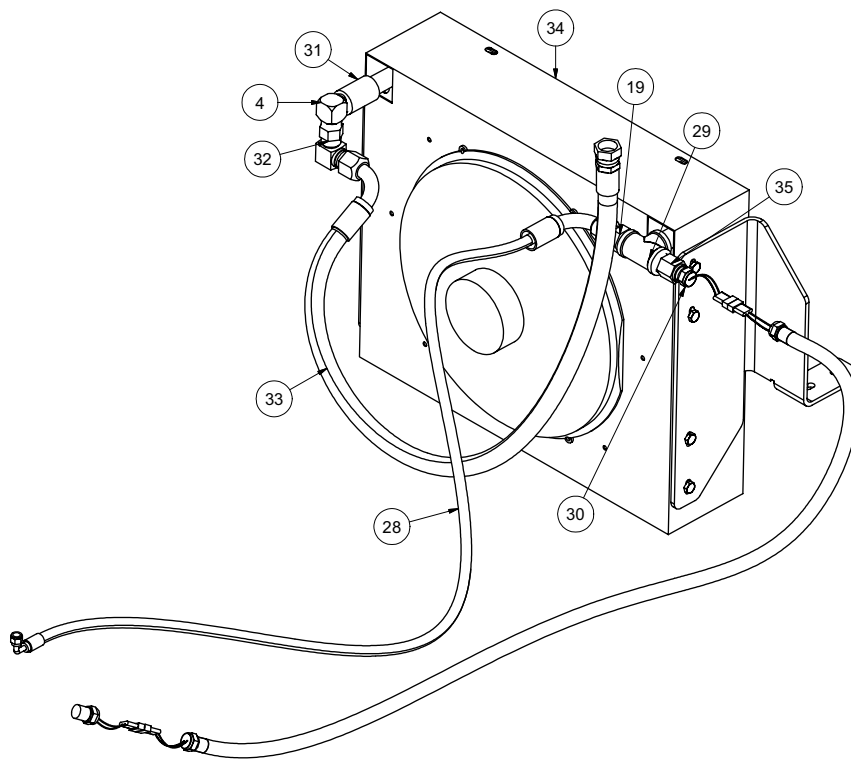
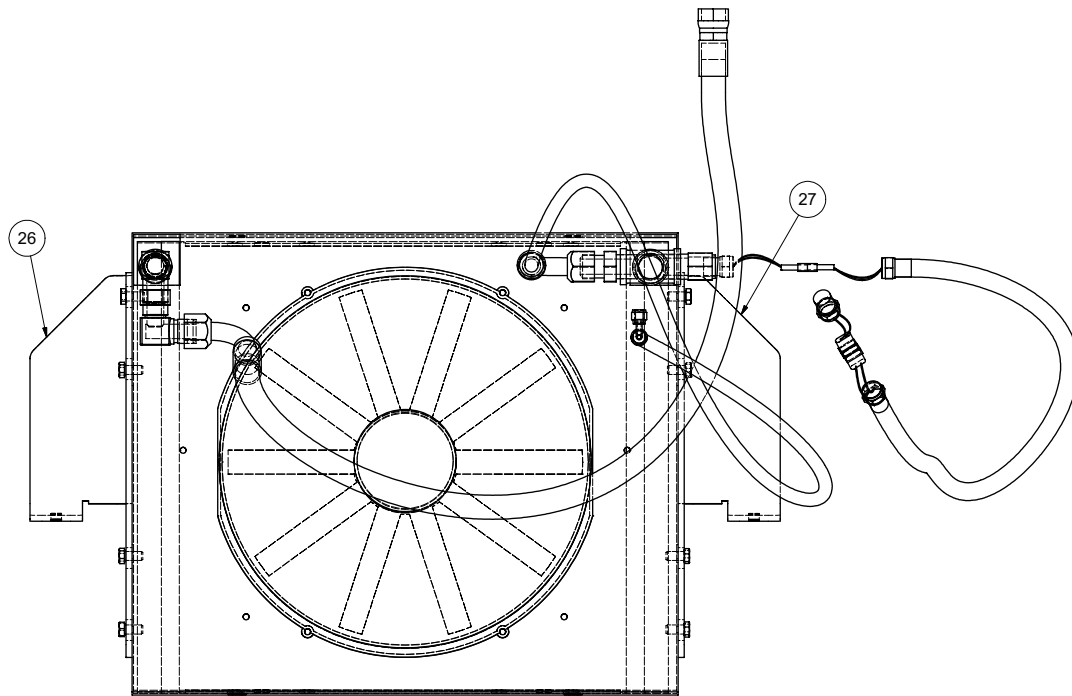

112009-E

VACASSY222

Compressor Tank Assembly

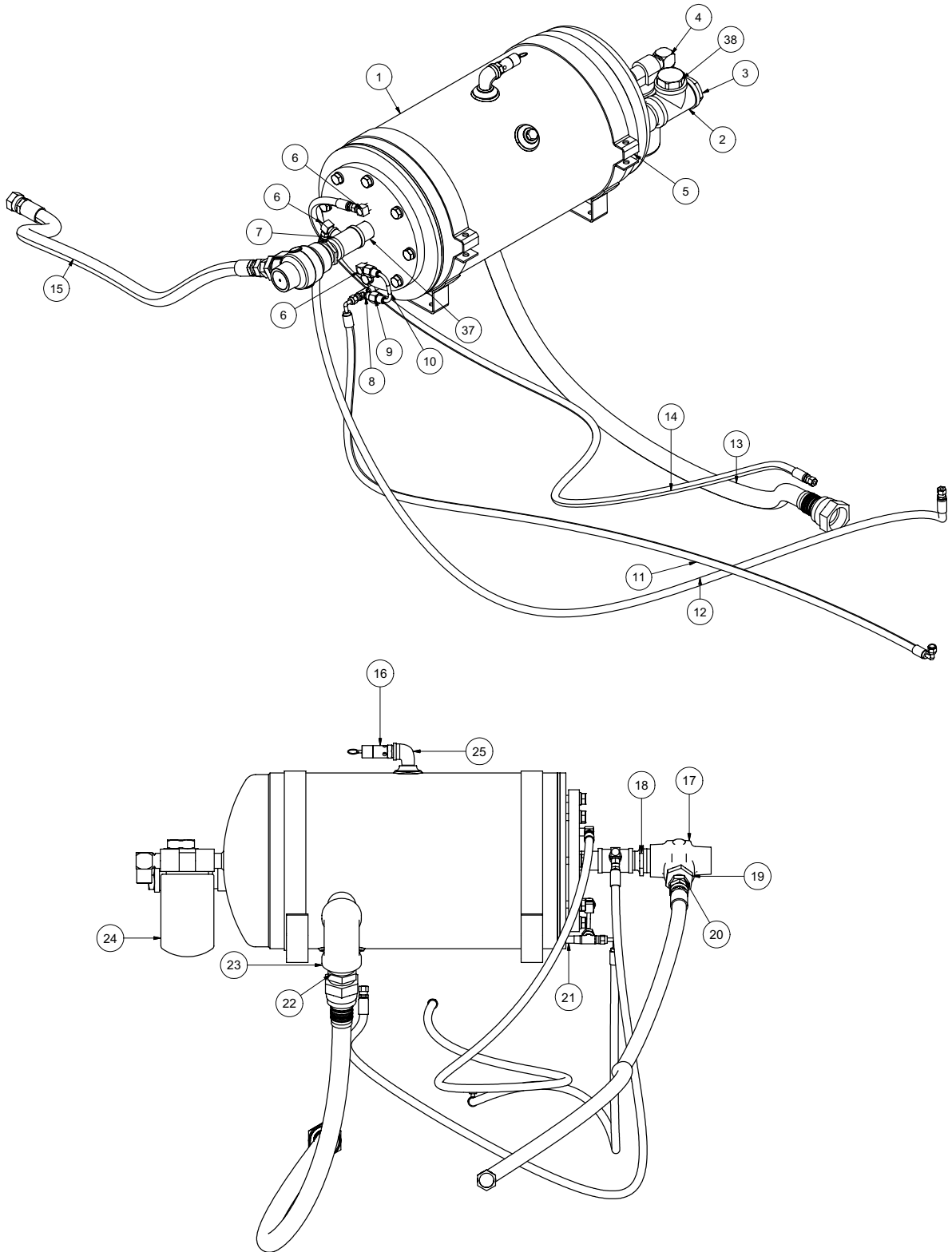

112009-E

VACASSY222

Compressor Tank Assembly

ITEM	QTY	PART NO.	DESCRIPTION
1	1	8044347-1	TANK RECEIVER
2	1	T402224	TEE, PIPE GALV 1 1/2"FP
3	1	8044347-8	GLASS, SIGHT OIL LEVEL 1 1 1/2
4	2	T401180	ELBOW,90 3/4"MP-3/4MJ
5	1	8044347-2	CLAMP BAND
6	3	T401100	ELBOW,90 1/4"MP-1/4"MJ
7	1	T402223	TEE, 1"FP-1/4"FP-1"FP
8	1	T402038	TEE, 1/4"MJ-1/4"MJ-1/4"MP
9	2	8044347-7	ORIFICE, HEX .047 DIA.
10	1	8044347-4	TUBE SEPARATOR DRAIN W/FITT
11	1	8044762	HOSE ASSY VAC 4-46 1/2" ST-90
12	1	8044744	HOSE ASSY VAC 4-76" ST-90
13	1	8044751	HOSE ASSY VAC 1 1/2- 66" ST-90
14	1	8044763	HOSE ASSY VAC 4-60" ST-90
15	1	8042860	HOSE ASSY VAC 12-95" ST-ST
16	1	8044347-6	VALVE, RELIEF 175 PSI 1/2 NPT
17	1	8044347-3	VALVE PRESSURE MINIMUM AIR
18	1	T421213	NIPPLE,HEX RED 1 1/4 X 1
19	1	T403015	REDUCER, 1 1/4"MP - 3/4"MP
20	1	T400100	UNION, 3/4"MP-3/4"MJ
21	1	T421010	NIPPLE,CLOSE 1/4"MP
22	1	T400580	UNION, 1-1/2"MP-1-1/2"MJ
23	1	T420335	ELBOW,90 1-1/2"FP PIPE
24	1	8043020	FILTER OIL COMPRESSOR SPIN-ON
25	1	8044347-5	ELBOW, PIPE STREET GALV 1/2
26	1	8044521	COMPRESSOR COOLER BRACKET
27	1	8044522	COMPRESSOR COOLER BRACKET
28	1	8044765	HOSE ASSY VAC 12-50" ST-90
29	1	T402160	TEE,3/4"FP-3/4"FP-3/4"FP
30	1	8043659	SWITCH TEMP OIL COMP 165F
31	1	T430040	COUPLING, FEMALE 3/4" FNPT
32	1	T401628	ELBOW,90 3/4"FJ-3/4"MJ
33	1	8044764	HOSE ASSY VAC 12-53" ST-90
34	1	8042497	OIL COOLER SHROUD
*	1	8042495	OIL COOLER FAN
*	1	8042496	OIL COOLER
35	1	T403085	REDUCER, 3/4"MP-1/2"FP
36	1	T421119	NIPPLE, PIPE GALV 1" X 2 1/2"
37	1	8044347-9	PLUG, O-RING 1 1/4 SAE

Water Tank Assembly

205 Gallon Saddle Tanks

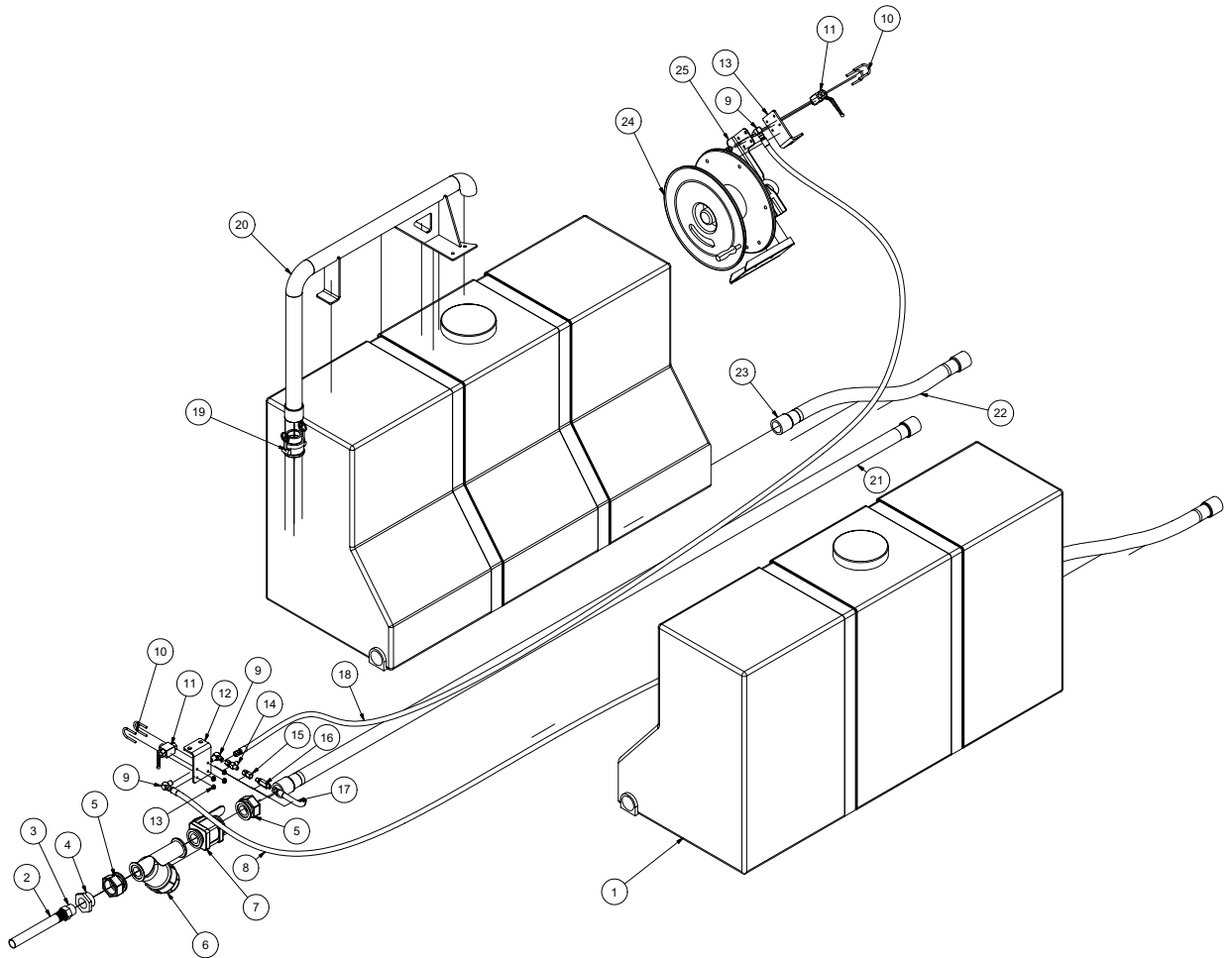

072009-E

VACASSY612

Water Tank Assembly

205 Gallon Saddle Tanks

ITEM	QTY	NUMBER	DESCRIPTION
1	2	8043805	TANK, WATER 205 GAL. POLY.
*	1	8030518	1/2" BULKHEAD 45 DEG
2	1	8043076	HOSE VAC CLEAR VINLY 1 1/4-37"
3	1	8044266	FITTING HOSE BARB 20HB-20MP
4	1	8043843	REDUCER, 1 1/4"MP - 1/2"FP GALV
5	2	8030996	ADAPTER, FEMALE 2"
6	1	8031001	Y-STRAINER, 2"
7	1	8030998	BALL VALVE, BANJO 1 1/2"ID
8	1	8043949	BALL VALVE TO TANK CLEAN OUT HOSE #6-215 ST-90
	2	T320040	FITTING, HOSE 6HO-6FJ
9	4	T401102	ELBOW, 6MJ-6MP
10	4	U010017	1 1/2" CLAMP HOOK 1/4-20 THD
11	2	8030351	STEEL BALL VALVE, 3/8" NPT
12	2	8040670	BALL VALVE BRACKET
13	8	U120142	NUT, LOCK FLANGED .250-20 G2
	8	U200020	WASHER, FLAT 1/4"
14	1	T402153	TEE, 6MJ-6MJ-6FJ
15	1	8031125	UNION, 4FP-6FJ
16	1	8030923	FILTER, WATER HIGH PRESSURE
17	1	8043664	BALL VALVE TO WATER PUMP HOSE #6-36 ST-90
18	1	8041477	HOSE REEL TO BALL VALVE HOSE #6-140 ST-ST
	2	T320040	FITTING, HOSE 6HO-6FJ
19	1	8031219	COUPLING, 2" ALUM MP X FCAMLOCK
20	1	8044398	QUICK FILL 205 GAL
21	1	8045635	HOSE VAC CLEAR VINLY 2"-122
	2	8043397	CLAMP VAC CLEAR HOSE 2"
22	2	8045636	HOSE VAC CLEAR VINLY 2"-36
	2	8043397	CLAMP VAC CLEAR HOSE 2"
23	6	T410115	HOSE BARB 2"
24	1	8043927	HOSE REEL
25	1	8043094	WATER HOSE VALVE BRACKET
26	1	8045386	SWITCH, WATER TANK BOTTOM LONG

* NOT SHOWN

Antifreeze Assembly

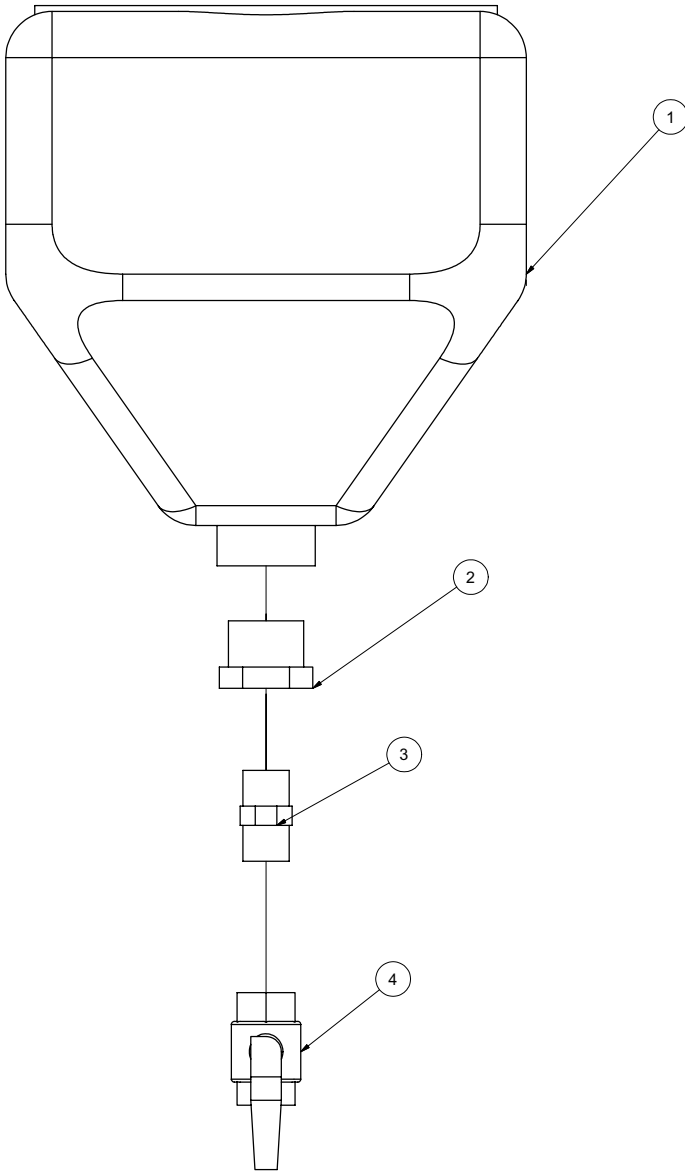

060309

VACASSY943

Antifreeze Assembly

ITEM	QTY	PART NO.	DESCRIPTION
1	1	8030394	ANTI-FREEZE TANK 4 GAL.
	4	U000180	SCREW, HC .312 -18 X .750
	4	U200040	WASHER, FLAT 5/16"
	4	U210040	WASHER, LOCK 5/16"
2	1	T400585	REDUCER, 20MP-12FP
3	1	T400800	UNION, 12MP-12MP
4	1	T000185	BALL VALVE, BRASS 3/4" FP

060309

VACASSY943

Hose Reel Assembly

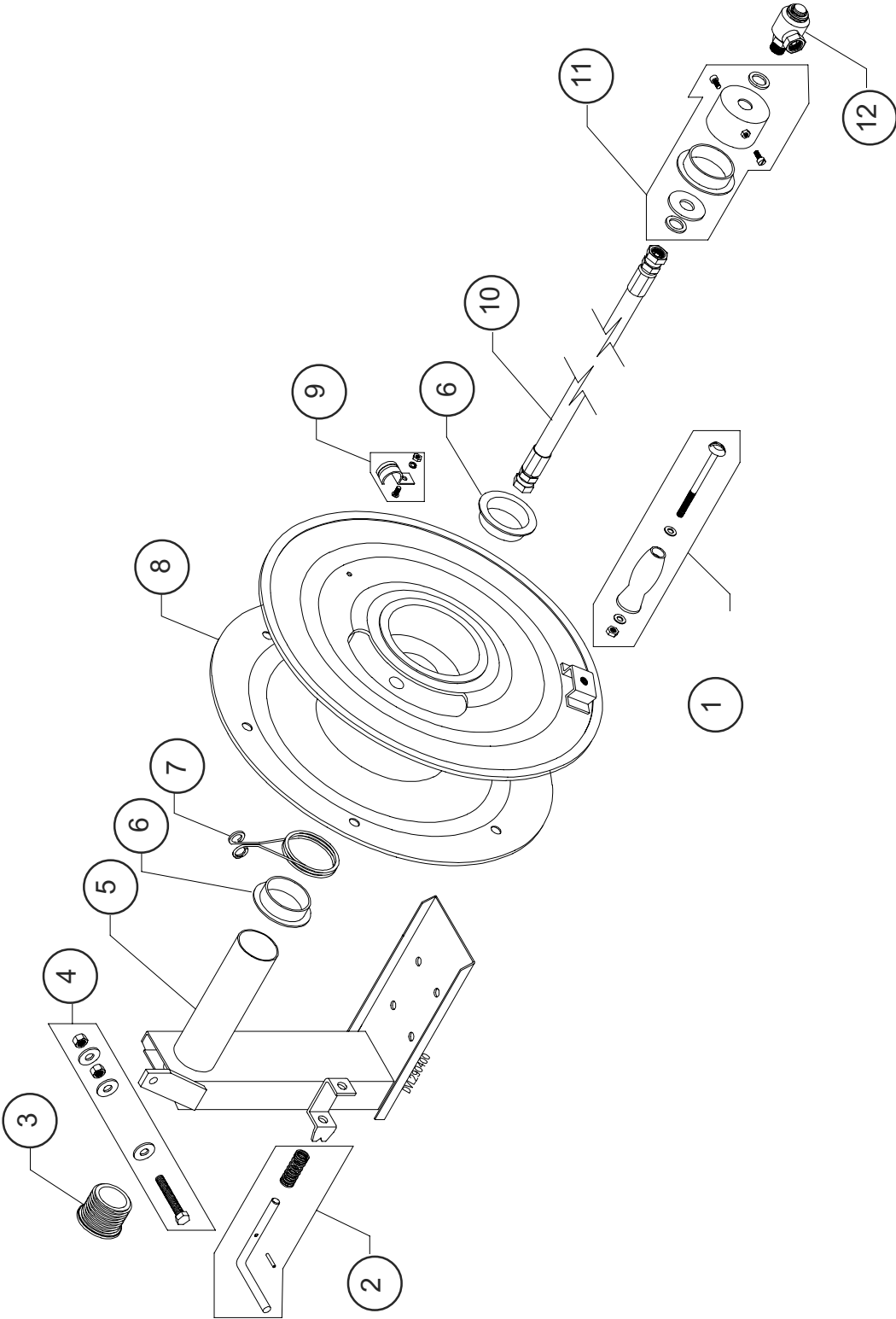

Hose Reel Assembly

ITEM	QTY	NUMBER	DESCRIPTION
	1	8043927	HOSE REEL, SP 3/8" X 150'
1	1	8043927-1	KIT-HOSE REEL HANDLE W/HARDWARE
2	1	8043927-2	KIT-LOCKING LATCH AND SPRING
3	1	8043927-3	KIT-HOSE GUIDE
4	1	8043927-4	KIT-SCREW, WASHER, BOLT SET
5	1	8043927-5	KIT-BASE
6	1	8043927-6	KIT-BUSHINGS (2)
7	1	8043927-7	KIT-BREAKING SPRING
8	1	8043927-8	KIT-REEL
9	1	8043927-9	KIT-HOSE CLAMP AND SCREW SET
10	1	8042412	HOSE VAC ASSY 6-33 ST-ST FNPT
11	1	8043927-11	KIT-SWIVEL MOUNTING COLLAR
12	1	8043927-12	KIT-3/8" HIGH PRESSURE SWIVEL 5000 PSI

Skid Assembly

V1200AW

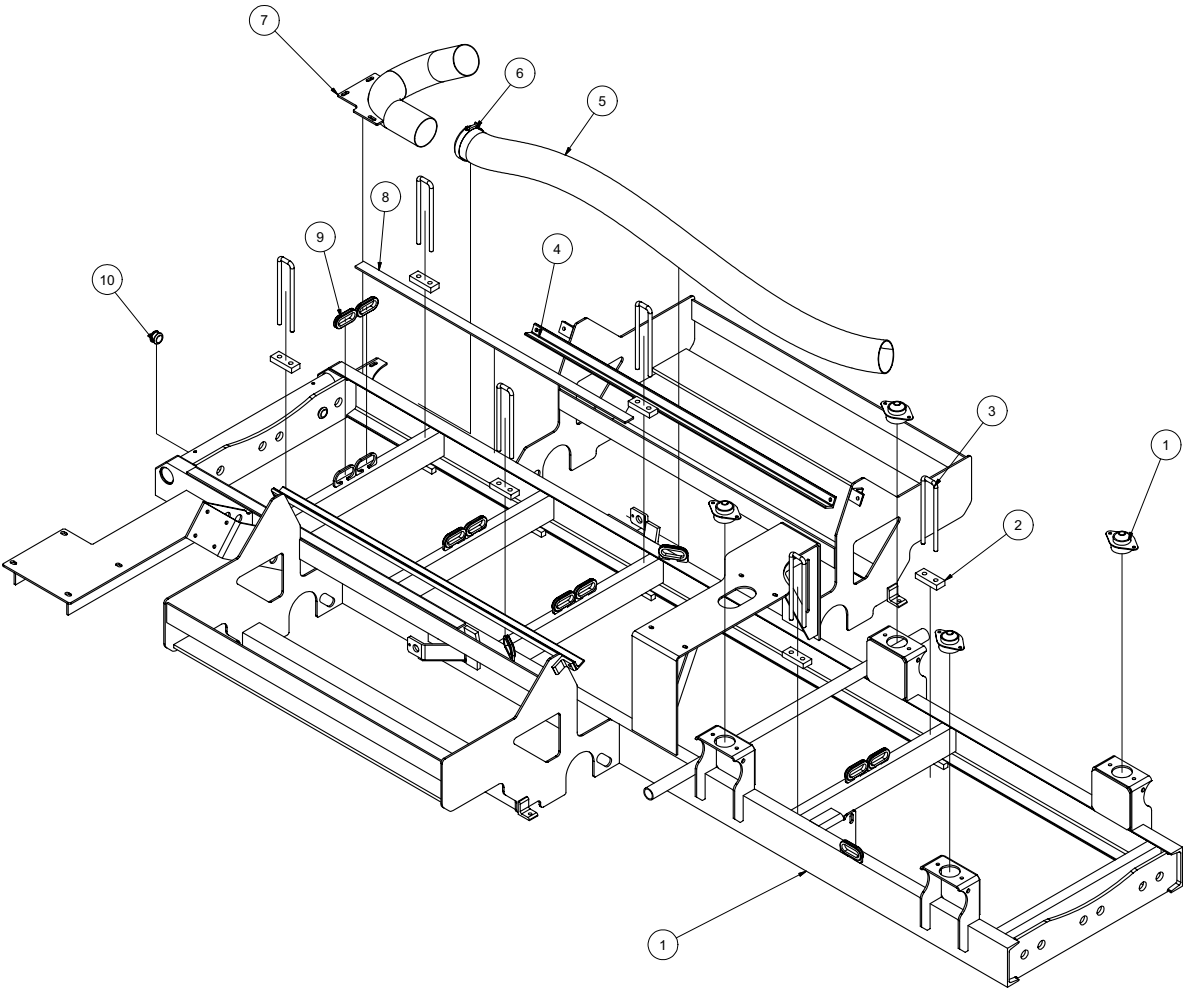

051809

VACASSY869

Skid Assembly

V1200AW

ITEM	QTY	PART #	DESCRIPTION
1	4	8030904	ISOLATOR 840LB.
	4	U000560	SCREW, HC 3/8"-16 X 3"
	4	8030389	WASHER, SNUBBLING
	4	U120110	NUT, LOCK 3/8"-16
	8	U000420	SCREW, HC 3/8"-16 X 1"
	24	U200060	WASHER, FLAT 3/8"
	8	U210060	WASHER, LOCK 3/8"
	8	U100060	NUT, HEX 3/8"-16
2	6	8040240	U-BOLT MOUNTING BLOCK
3	6	8040038	U-BOLT, 1/2 -13 X 10"LG - 1 5/8" GAP GR.8
	6	8040038-1	WASHER, 1/2"
	6	8040038-2	NUT, 1/2"-20
4	2	8044456	WATER TANK ANGLE 125GAL.
5	1	8040970	HOSE ASSY VAC 4-70 ST-ST
6	2	8042606	CLAMP, T-BOLT 4" (450)
7	1	8044451	EXHAUST ELBOW TANK PIVOT 4"
8	2	8041376	PLASTIC STRIP 1/4" X 1/2" X 30"
	6	U030015	SCREW SOCKET FLAT HEAD 1/4" -20 X 3/4"
9	11	8042812	GROMMET 2"ID 3"OD 1/4"WOG TRAILER SLOT MODEL
10	2	8041686	GROMMET 1"ID - 1 1/4"DOG - 1/4"WO
11	1	8044431	TRAILER SKID - 500HD W/SADDLE TANK

051809

VACASSY869

Hydraulic Jack Option

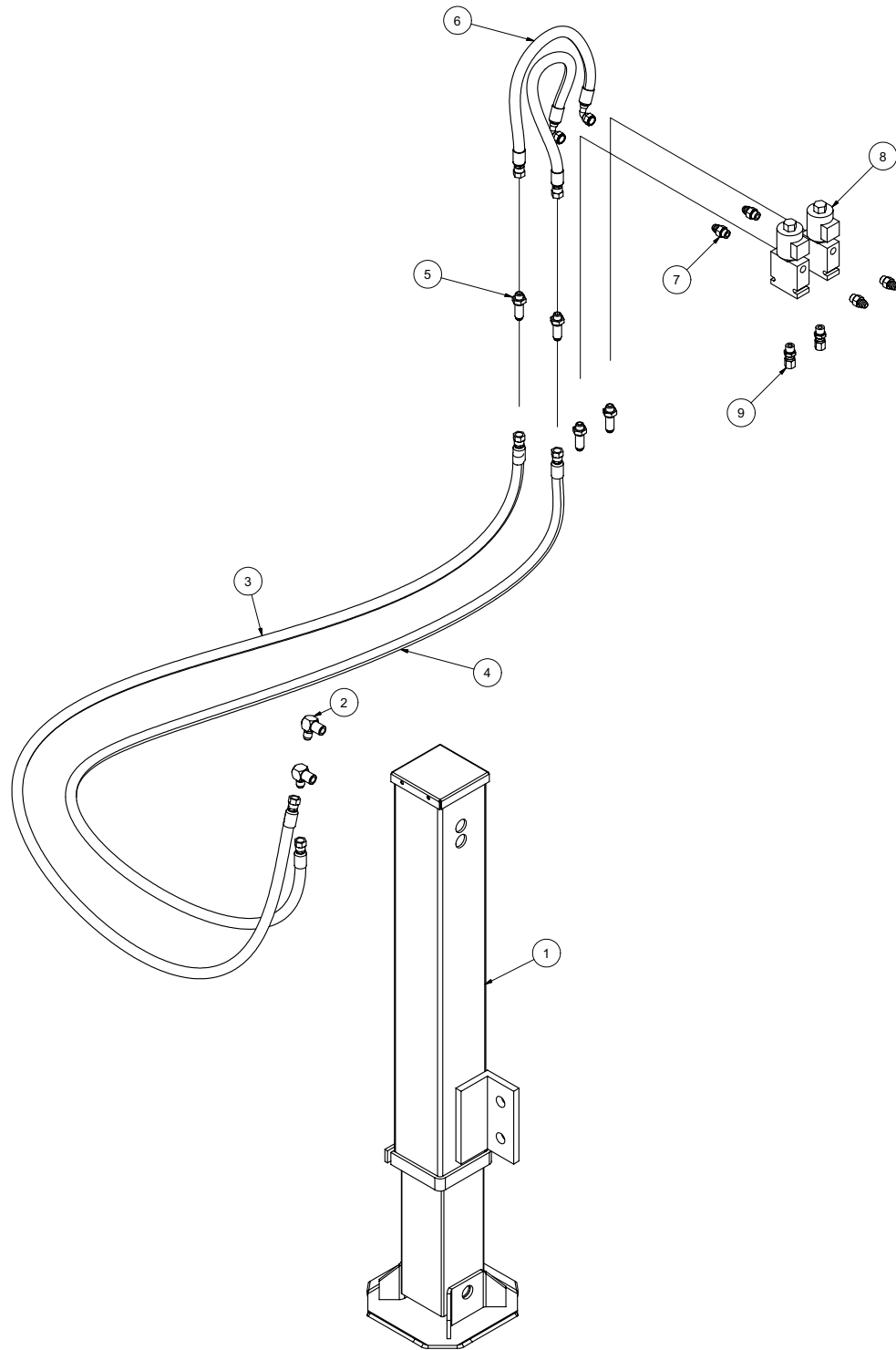

072808

VACASSY956

Hydraulic Jack Option

ITEM	QTY	PART #	DESCRIPTION
1	1	8043653	HYDRAULIC JACK CYLINDER
2	2	T401103	ELBOW 90 DEG 3/8"MJ - 1/4"FJ
3	1	8042661	HOSE ASSY VAC 6-66 ST-90
4	1	8041442	HOSE ASSY VAC 6-60 ST-90
5	2	T400391	BULKHEAD, 3/8"MJ - 3/8"MJ
6	2	8040973	HOSE ASSY VAC 6-20 ST-90
7	4	T400037	UNION, 3/8"MB - 3/8"MJ
8	2	8041788	SOLENOID VALVE
9	2	8030512	UNION, 3/8"MB - 3/8"FJ
*	1	X000274	SWITCH ROCKER DPDT

* NOT SHOWN

072808

VACASSY956

Surge Brake Option

V500

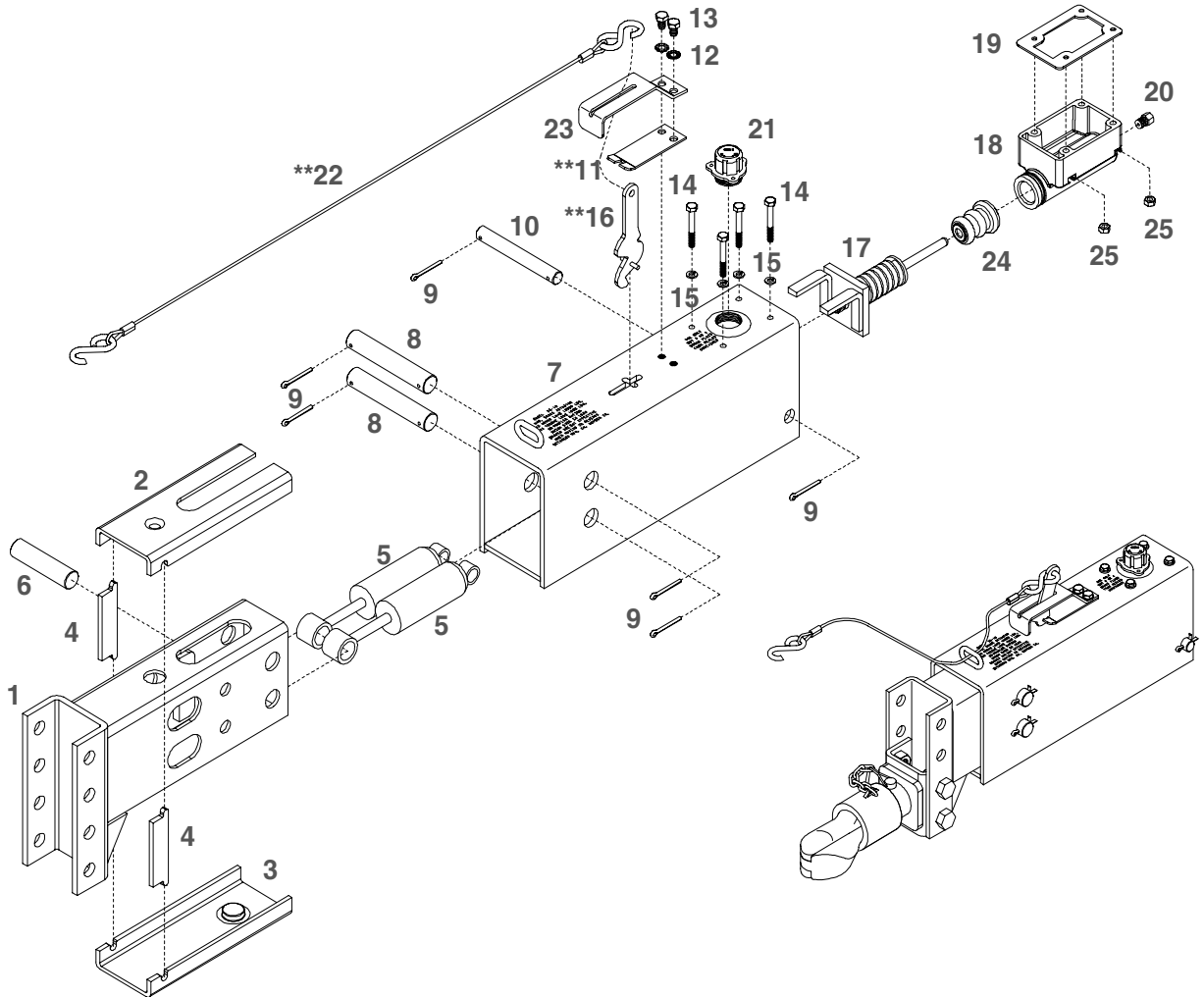

051408

VACASSY948

Surge Brake Option

V500

ITEM	QTY	NUMBER	DESCRIPTION
1	1	8040790-1	INNER SLIDER TUBE CHAN. DOWN
2	1	8040790-2	TOP WEAR PAD
3	1	8040790-3	BOTTOM WEAR PAD
4	2	8040790-4	SPACER BLOCK
5	2	8040790-5	DAMPER SHOCK
6	1	8040790-6	FRONT SHOCK PIN (ZINC PLATED)
7	1	8040790-7	OUTER CASE
8	2	8040790-8	CONNECTING PIN (ZINC PLATED)
9	6	8040790-9	5/32" X 1-1/4" COTTER PIN
10	1	8040790-10	REAR SHOCK PIN (ZINC PLATED)
11	1	8040790-11	EMERGENCY LEVER SPRING (ZINC PLATED)
12	2	8040790-12	5/16" EXTERNAL TOOTH LOCK WASHER
13	2	8040790-13	5/16"-18 UNC X 5/8" HEX HEAD BOLT GR.5
14	4	8040790-14	1/4"-20 UNC X 2" HEX HEAD BOLT GR.5
15	4	8040790-15	1/4" LOCK WASHER
16	1	8040790-16	EMERGENCY LEVER (ZINC PLATED)
17	1	8040790-17	PUSH ROD ASSEMBLY
18	1	8040790-18	COMPOSITE MASTER CYLINDER (DRUM BRAKES)
19	1	8040790-19	REPLACEMENT MASTER CYL. GASKET ONLY
20	1	8040790-20	1/8" PIPE-3/16" FITTING W/ORIFICE (DRUM)
21	1	8040790-21	MASTER CYLINDER CAP W/DIAPHRAGM AND O-RING
22	1	8040790-22	3/32" CABLE WITH HOOKS (BOTH ENDS)
23	1	8040790-23	LEVER GUIDE (ZINC PLATED)
24	1	8040790-24	MASTER CYL. PROTECTIVE BOOT
25	4	8040790-25	1/4"-20 UNC HEX NUTS

051408

VACASSY948

HOSES

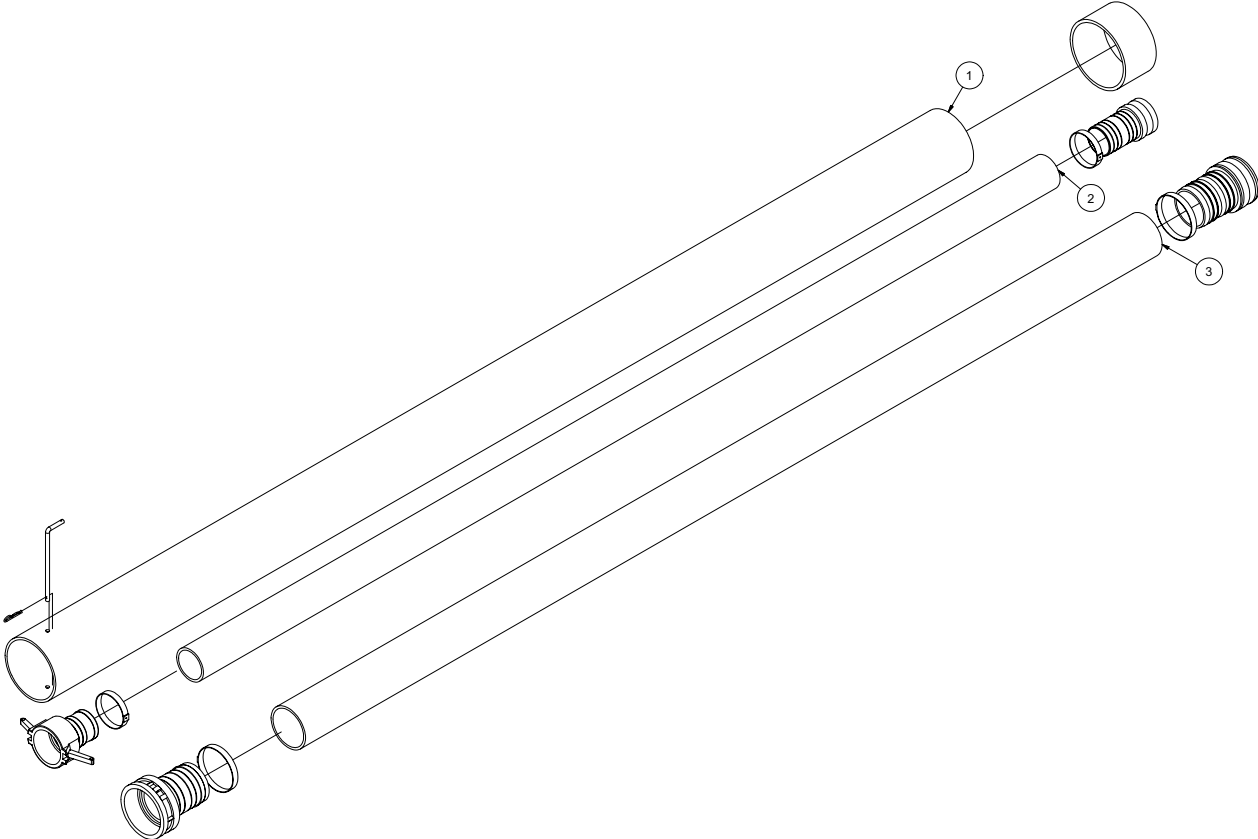

032610-E

VACASSY945

HOSES

ITEM	QTY	PART NO.	DESCRIPTION	
1	1	8041102	6" PVC STORAGE TUBE 10' LG	
	1	8030925	END CAP 6"	
	1	8041485	LANYARD CABLE	
	2	8040959	HOSE STORAGE CLAMP	
	4	U200060	WASHER, FLAT 3/8"	
	4	U100060	NUT, HEX 3/8"	
	1	8041101	HOSE STORAGE RETAINING ROD	
	1	R700175	R-CLIP, 1 5/8 SHANK	
	2	1	8040338	HOSE VAC KANAFLEX 3-110
		1	8046441	CAMLOCK, 3" AL FCAM X M BARB
1		8046440	CAMLOCK, 3" AL MCAM X M BARB	
2		8030356	CLAMP, 4" PUNCHLOCK P16-S	
3	1	8042310	HOSE VAC KANAFLEX 4-112	
	1	8046444	CAMLOCK, 4" AL FCAM X M BARB	
	1	8046443	CAMLOCK, 4" AL MCAM X M BARB	
	2	8030912	CLAMP, 4.5" PUNCHLOCK P18-S	

Tool Rack Assembly

HD

I-BEAM TRAILER

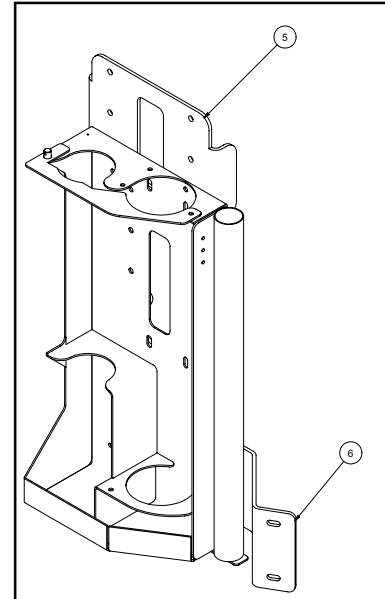
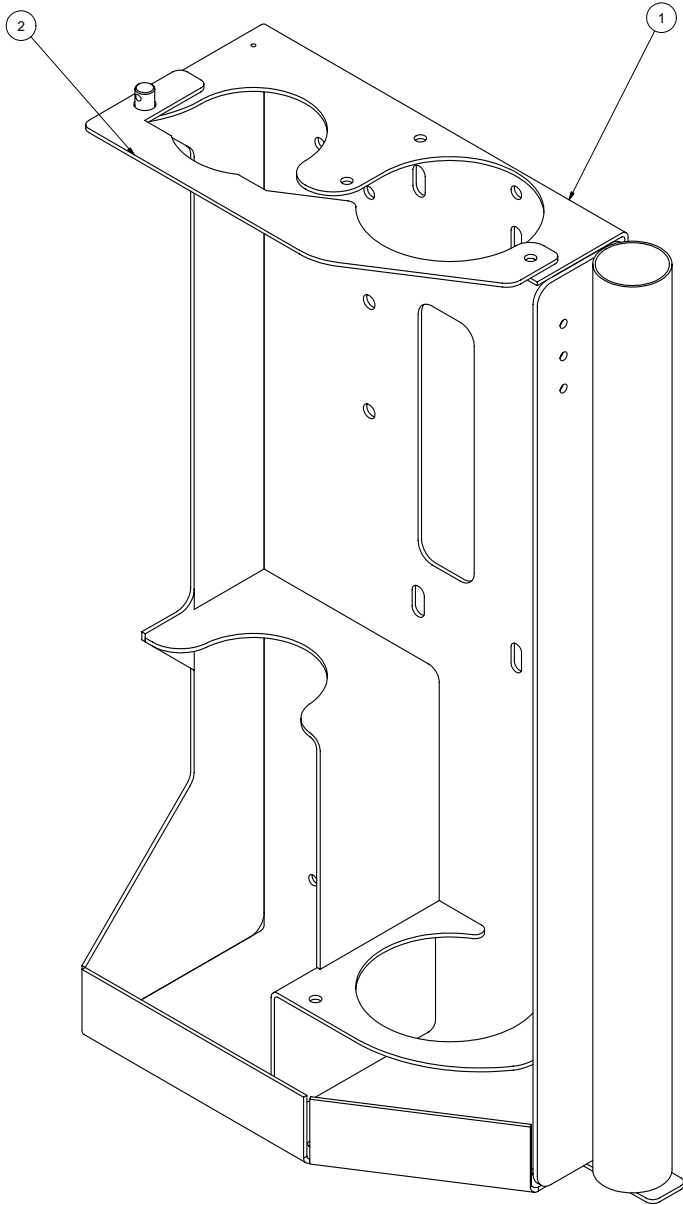

SKID UNIT

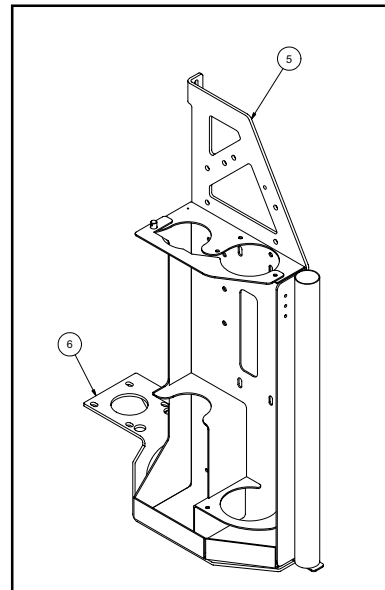

090909-E

VACASSY758

Tool Rack Assembly

ITEM	QTY	PART NO.	DESCRIPTION
1	1	8040985	TOOL RACK WELDMENT, HD
2	1	8040989	TOOL RACK CLOSURE, HD
	1	R700175	R CLIP 7/8"
	1	8041259	STRAP, 10"
	1	8041485	LANYARD CABLE
	1	8041244	CLEVIS PIN 1/2" DIA. 3/4"
3	1	8044818	ANTIFREEZE BRACKET (I-BEAM TRAILER)
	4	U000020	SCREW, HC 5/16 - 18 X 1.00"
	4	U000180	SCREW, HC 5/16 - 18 X .750"
	16	U200040	WASHER, FLAT 5/16"
	8	U210041	NUT, LOCK, NY 5/16"
4	1	8044817	TOOL RACK BRACKET (I-BEAM TRAILER)
	3	U000420	SCREW, HC .375 - 16 X 1.00
	3	U120110	NUT, LOCK .375 - 16
	6	U200600	WASHER, FLAT .375
5	1	8041780	ENCLOSURE STIFFENER BRACE (SKID UNITS)
	4	U000040	SCREW, HC 1/4"-20 X .750"
	8	U200020	WASHER, FLAT .250"
	4	U120100	NUT, LOCK .250"
6	1	8043601	TOOL RACK BRACKET - VK (SKID UNITS)
	4	U000420	SCREW, HC .375"-16 X 1.00"
	8	U200060	WASHER, FLAT .375"
	4	U120110	NUT, LOCK .375-16
	2	U000040	SCREW, HC 1/4"-20 X .750"
	4	U200020	WASHER, FLAT .250"
	2	U120100	NUT, LOCK .250"

090909-E

VACASSY758

Tools (Option)

HD Reduction Tool

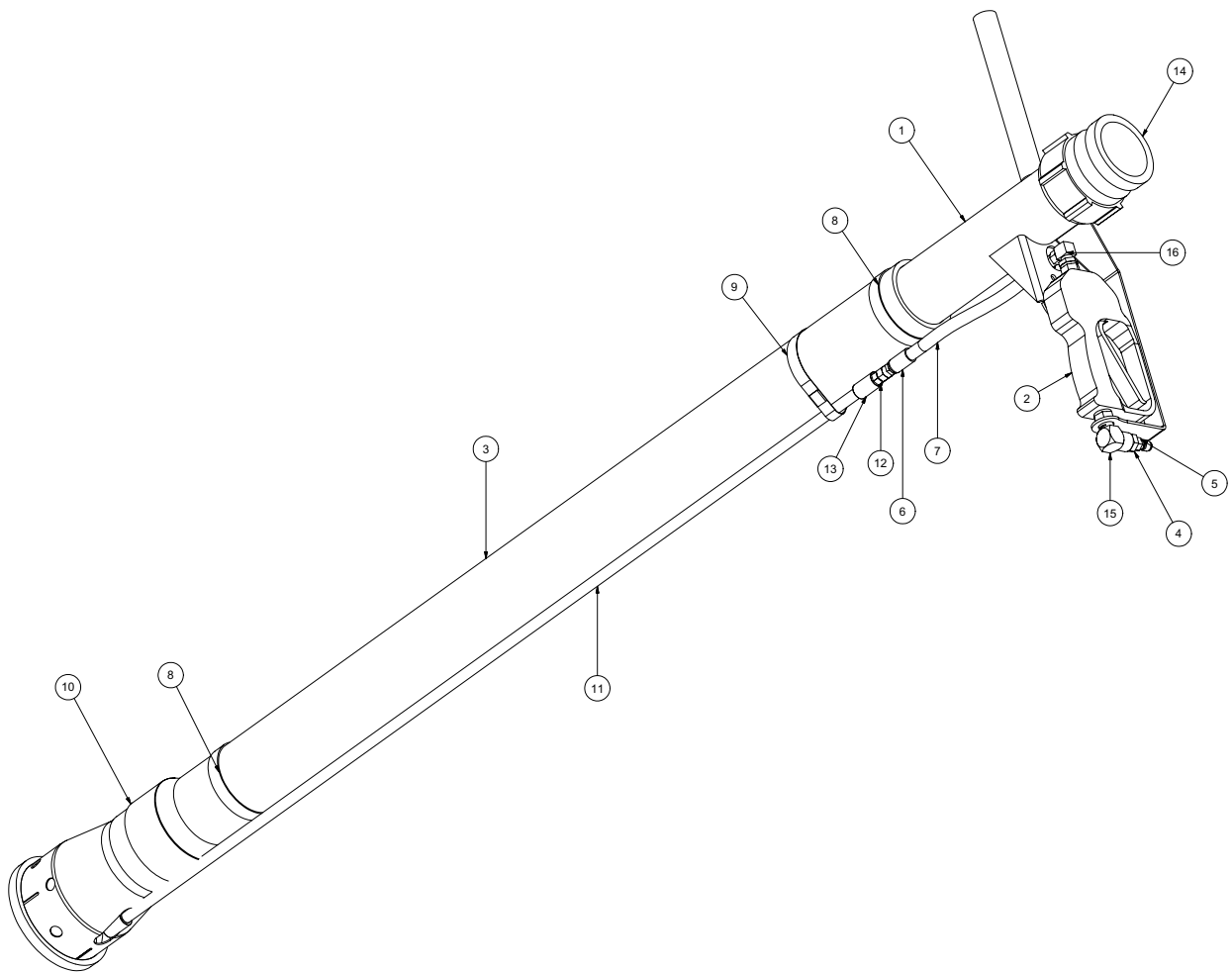

122607

VACASSY707

Tools (Option)

HD Reduction Tool

ITEM	QTY	PART NO.	DESCRIPTION
-	-	8043118	TOOL VAC REDUCTION HD COMPLETE
1	1	8042862	TOOL VAC HEAD ASSY 3"
2	1	8042026	STRAIGHT SPRAY GUN
3	1	8042811	TOOL VAC REDUCTION PVC 3" X 48"
4	1	T400023	UNION 6MP 4FP
5	1	8030486	WATER QD 1/4 MNPT SS
6	2	T320030	FITTING, HOSE 4HO 4FJ
7	1	8031278	HOSE ASSEMBLY REDUCTION TOOL
8	2	8030244	VAC CLAMP BAND 3 1/2" PUNCHLOCK
9	1	8030244	VAC CLAMP BAND 3 1/2" PUNCHLOCK
10	1	8041099	TOOL VAC REDUCTION HD LOWER ASSY
11	1	8030247	VAC WATER SUPPLY TUBE
12	1	T400020	UNION 1/4" MP-1/4" MJ STRAIGHT
13	1	8030367	VAC FITT 1/4" FF-S
14	1	8030391	BANJO 3" MALE 3" FNPT
15	1	T401065	ELBOW, 3/8 MP - 3/8 FP
16	1	T401100	ELBOW 4MP 4MJ 90
*	2	8030370	REDUCTION TOOL NOZZLE
*	2	8031268	REDUCTION TOOL NOZZLE 45 DEG

* NOT SHOWN

Tools

4" Suction Tool

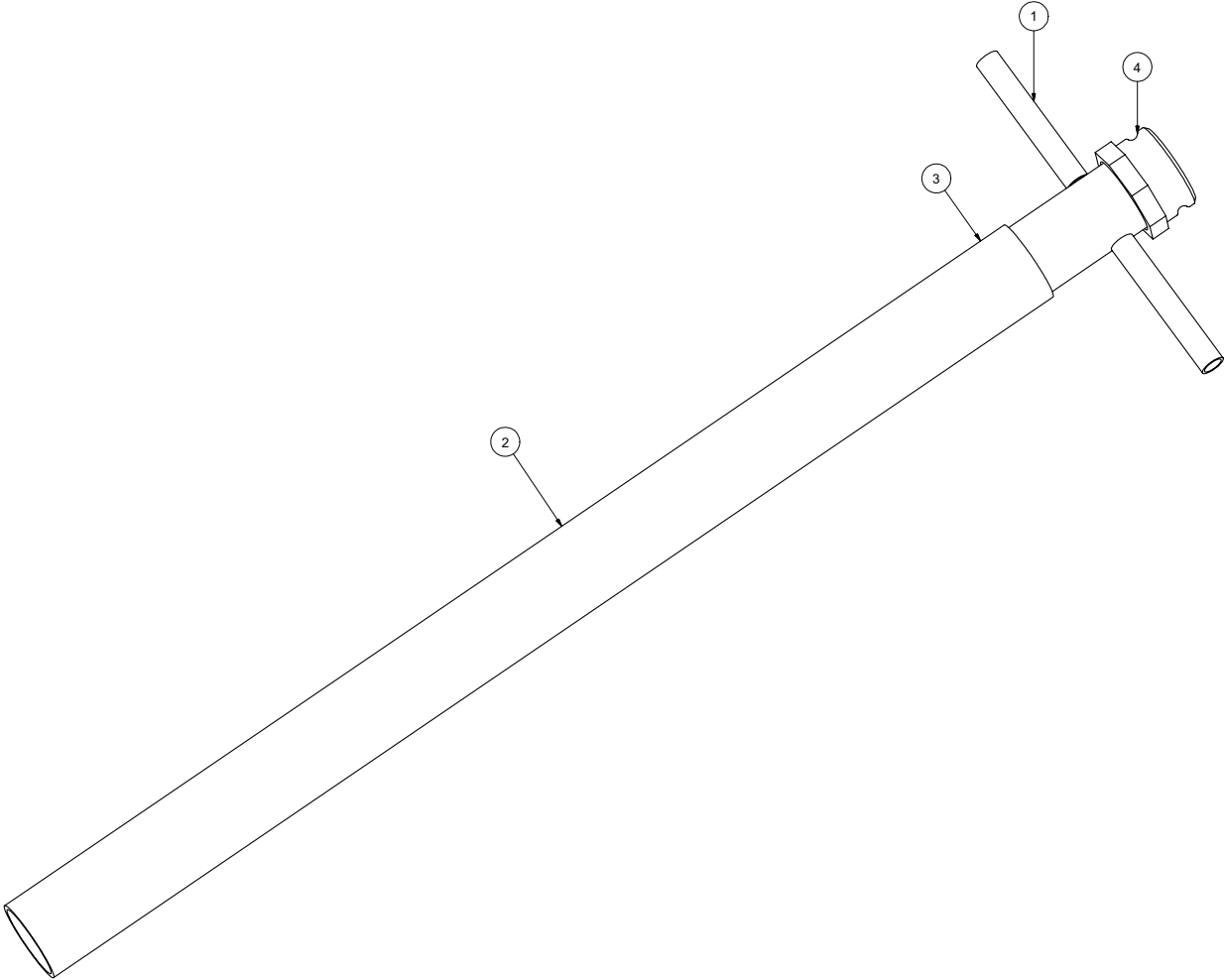

072308

VACASSY710

Tools

4" Suction Tool

ITEM	QTY	NUMBER	DESCRIPTION
	1	8040983	TOOL VAC SUCTION 4" COMPLETE
1	1	8040981	TOOL VAC HANDLE ASSEMBLY 4"
2	1	8040982	PVC VACUUM TUBE 4"
3	1	8030912	CLAMP, 4.5" PUNCHLOK
4	1	8030844	COUPLING, 4" BANJO

072308

VACASSY710

Tools

Wash Wand

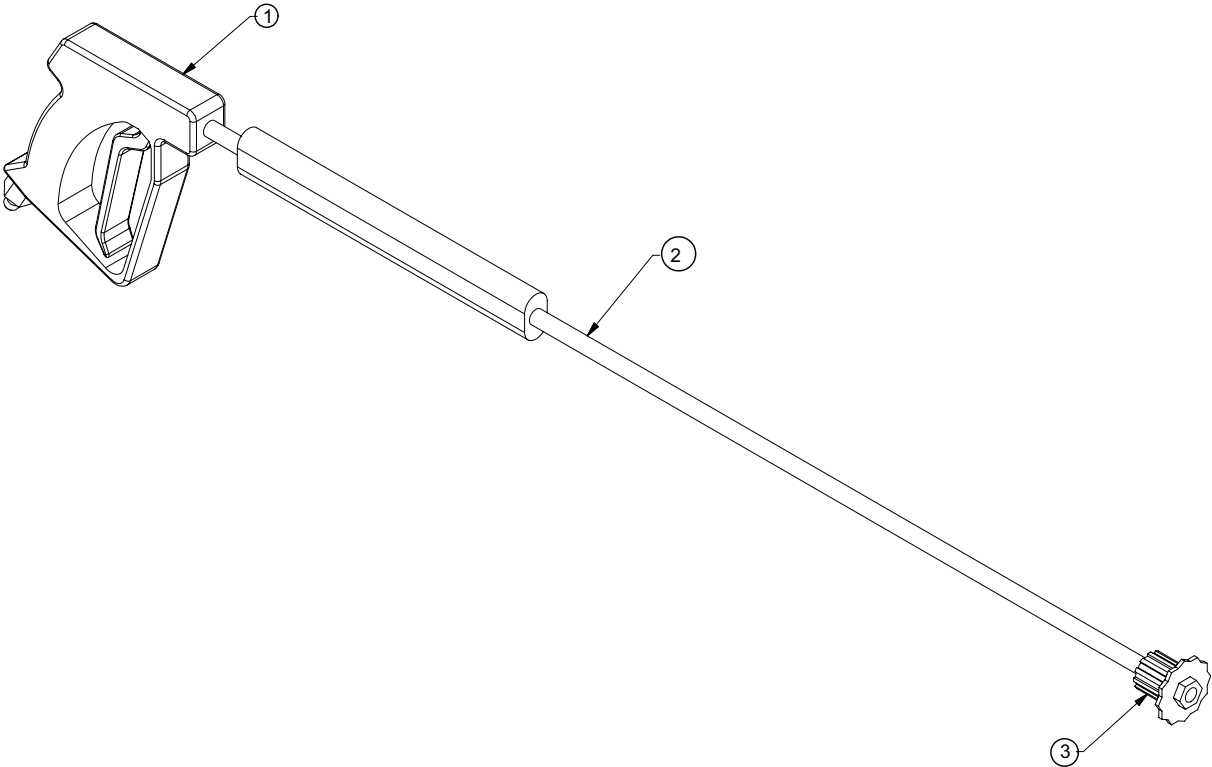

042610-E

VACASSY711

Tools

Wash Wand

Item	Qty	Number	Description
1	1	8030348	TOOL VAC SPRAY WAND COMPLETE
2	1	8030928	TRIGGERASSEMBLY
3	1	8030847	WAND
		8031308	NOZZLE,#6 40 DEGREE FOR WAND

042610-E

VACASSY711

Valve Box Cleanout Tool

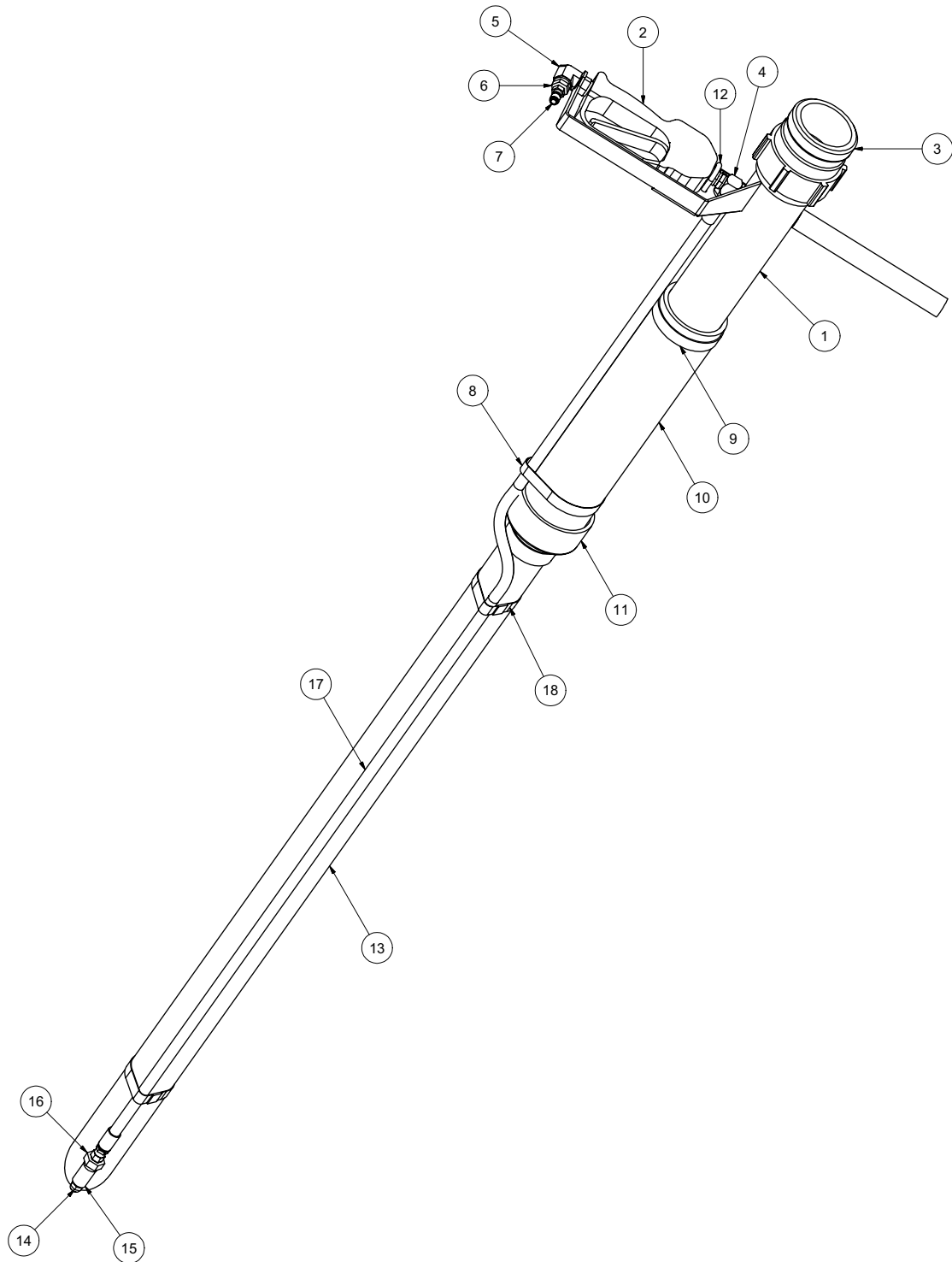

073108

VACASSY714

Valve Box Cleanout Tool

ITEM	QTY	PART NO.	DESCRIPTION
1	1	8042862	REDUCTION TOOL HEAD WELD'T
2	1	8042026	STRAIGHT SPRAY GUN
3	1	8030391	BANJO 3" MALE FNPT
4	1	T401100	ELBOW 4MP 4MJ 90
5	1	T401065	ELBOW, 3/8 MP - 3/8 FP
6	1	T400023	REDUCER 6MP 4FP
7	1	8030486	WATER QD 1/4 MNPT SS
8	1	8042855	CLAMP HOSE T-BOLT 375
9	1	8042605	CLAMP HOSE T-BOLT 350
10	1	8044096	PVC 3" DIA X 9" LONG
11	1	8030669	REDUCER PVC 3" TO 2" SLIP ON
12	1	U010019	U-BOLT 1_4-20 X 3_4 WIDE X 2 1_4 LONG
13	1	8044097	PVC 2" DIA X 42.5" LG
14	1	8031246	NOZZLE, .100 X 0 DEG
15	1	T422010	COUPLING 1/4"FP
16	1	U400020	UNION, 1/4" MP - 1/4" MJ
17	1	8044098	HOSE ASSY VALVE BOX CLEANOUT TOOL
18	2	U800070	CLAMP, BAND 3.00" X .500

Tools

Lawn Sweeper 3''

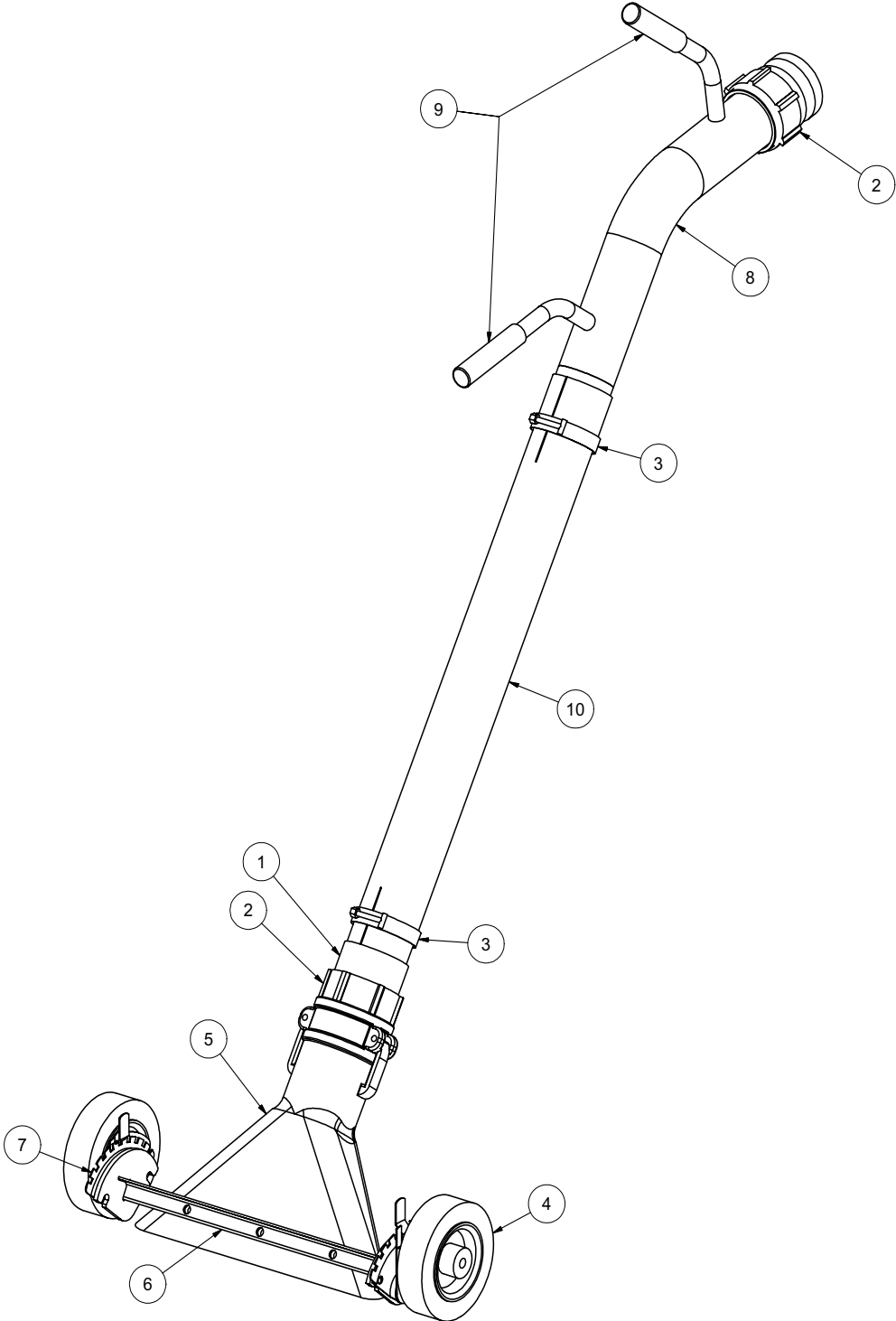

071708

VACASSY713

Tools

Lawn Sweeper 3"

ITEM	QTY	PART #	DESCRIPTION
1	1	8030287	3" HOSE X 3" MNPT ADAPTER
2	2	8030391	BANJO 3" MALE 3" FNPT
3	2	8042605	CLAMP T-BOLT 3" (350)
4	2	8043887	WHEEL 6" PNEUMATIC
5	1	8043925	DUCKBILL 3" ALUMINUM
6	1	8043928	LS WHEEL WELDMENT
7	1	8043931	WHEEL ADJUSTERS (1 LEFT/1 RIGHT)
8	1	8043933	LS HANDLE WELDMENT
9	2	J300080	HANDLE GRIP
10	1	8043932	PVC 3" X 30"

071708

VACASSY713

Surface Cleaner

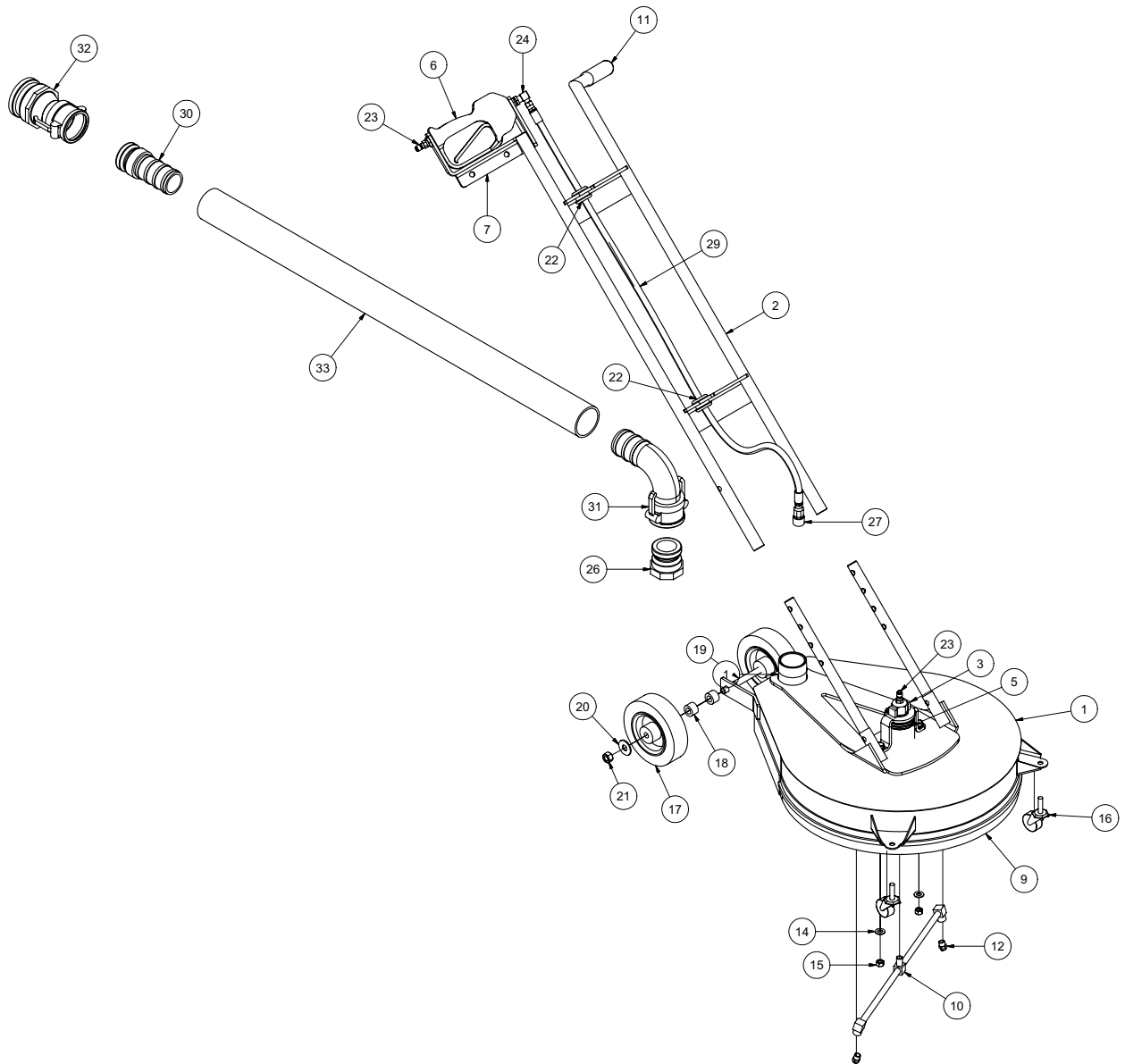

091710-E

VACASSY715

Surface Cleaner

ITEM	QTY	PART NO.	DESCRIPTION
1	1	8041887	SURFACE CLEANER - HEAD ASSY
2	1	8042019	HANDLE ASSY
3	1	8041890	ROTARY RETAINER
4	2	8042022	HANDLE ADJ. TUBE
5	1	8042027	ROTARY HEAD
6	1	8042026	STRAIGHT SPRAY GUN
7	1	8042020	GUN CAPTURE BRACKET
8	1	8043467	SQUEEGEE
9	1	8042030	FLEXIBLE BRUSH
10	1	8042028	ROTARY ARM
11	1	J300080	GRIPHANDLE
12	2	8031419	NOZZLE, #4.0 25 DEG
13	2	U000420	SCREW, HC 3/8-16 X 1.00
14	4	U200600	WASHER, FLAT 3/8"
15	2	U100060	NUT, HEX 3/8-16
16	2	8043387	SWIVEL CASTER 1 5/8"
17	2	8043887	WHEEL 6" PNEUMATIC
18	2	8043591	SURFACE CLEANER REAR WHEEL SPACER
19	1	U001060	SCREW, HC 1/2-13 X 6.0
20	2	U200100	WASHER, FLAT 1/2"
21	1	U120120	NUT, LOCK 1/2-13
22	2	8041686	GROMMET 1"ID- 1 1/4"DOG-1/4"WO
23	2	8030486	WATER QD 1/4 MNPT SS
24	1	T401100	ELBOW 4MP 4MJ 90
25	1	T320030	FITTING, HOSE 4HO 4FJ
26	1	8043389	ADAPTER M2" F THREAD
27	1	8030526	FITTING, QD WATER 1/4"F-1/4"FP
28	1	T320300	FITTING, HOSE 4HO 4MP
29	1	8044108	HOSE VAC SURFACE CLEANER
30	1	8043392	ADAPTER M2" F THREAD
31	1	8043391	REDUCER COUPLER 2"F 90 DEG - 3"M
32	1	8043395	REDUCER COUPLER 2" X 3" ADAPTER
33	1	8043398	HOSE VAC CLEAR 2"
*	2	8043397	CLAMP VAC CLEAR HOSE 2"
*	4	U360020	PIN, U-LOCK 3/8 X 1.5

Auxillary Hydraulics

36 HP

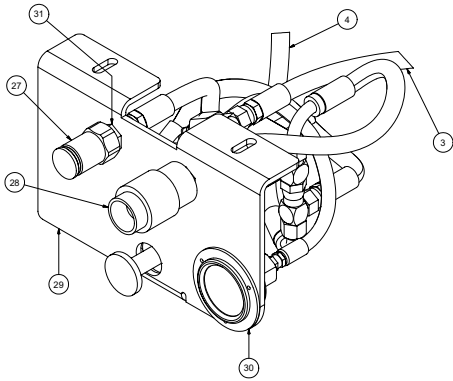
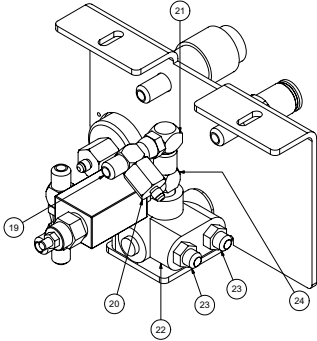
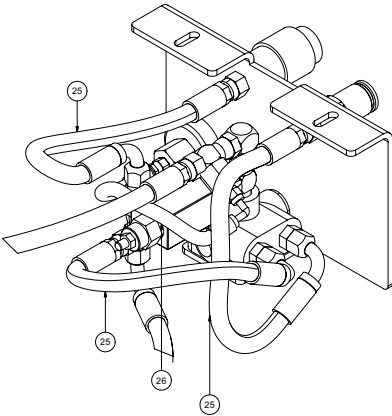
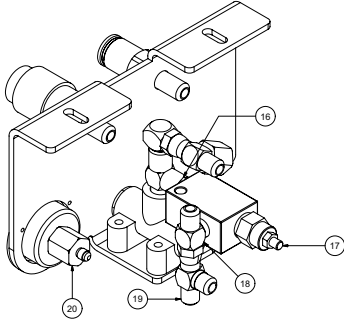
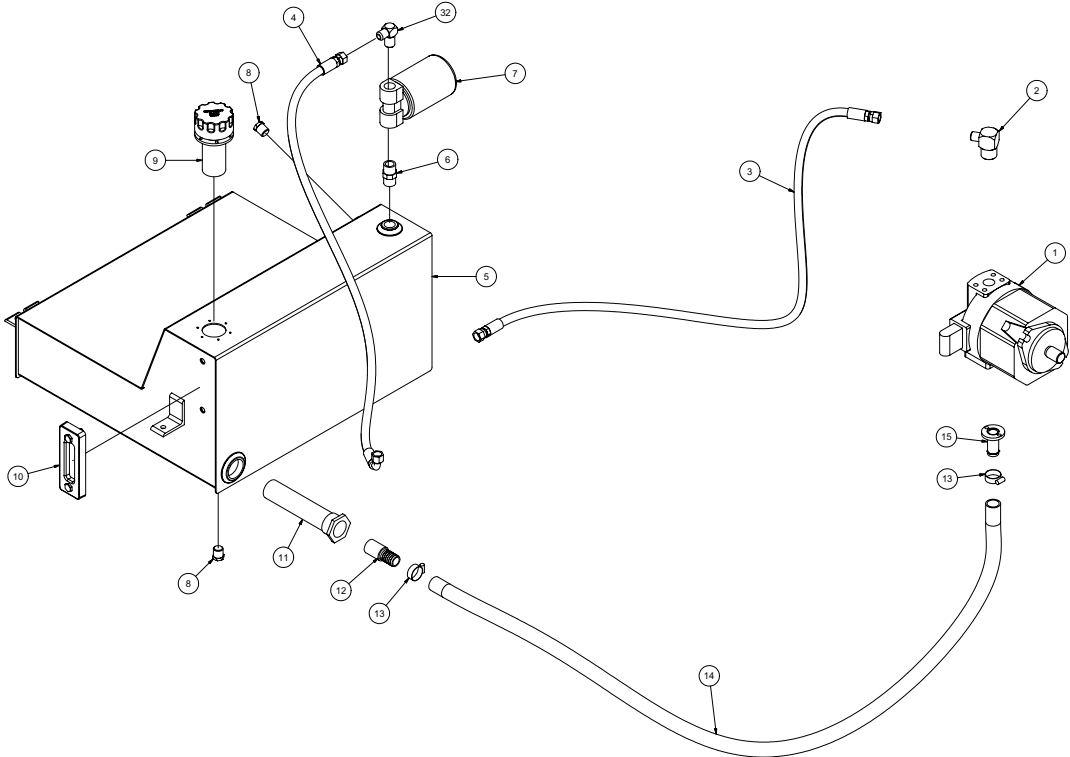

072808

VACASSY953

Auxillary Hydraulics

36 HP

ITEM	QTY	PART	DESCRIPTION
1	1	8030652	AUX. HYD PUMP
2	1	T401120	ELBOW 90 DEG 3/8"MP - 1/2"MJ
3	1	8041868	SUPPLY HOSE ASSY VAC 8-130 ST-ST
4	1	8041869	RETURN HOSE ASSY VAC 8-100 ST-90
5	1	8041143	HYDRAULIC TANK
6	1	T400800	UNION, HEX 12MP - 12MP
7	1	T700080	FILTER, HYD ASSY
	1	T700090	FILTERELEMENT
8	2	T405065	PLUG, 3/4"MP
9	1	2050068	CAP ASSY HYD TANK
10	1	T720115	GUAGE, SIGHT, HYD OIL
11	1	8011058	SUCTION STRAINER 100 MESH
12	1	8043963	HOSE FITTING 1"NPT - 1" HOSE BARB
13	2	8044011	CLAMP T-BOLT 150
14	1	8044010	SUCTION HOSE VAC HYDSUC 16-28
15	1	8044009	ELBOW 45 DEG 1" HOSE BARB - 3/4" MNPT
	1	T403050	REDUCER 3/4 FNPT - 1/2 MNPT
16	1	T404020	UNION, 1/2"MP - 1/2"MP
17	1	8041829	RELIEF VALVE
18	1	T402120	TEE, 1/2"MJ - 1/2"MP - 1/2"MJ
19	2	T402155	TEE, 1/2"FJ - 1/2"MJ - 1/2"MJ
20	2	T400700	REDUCER, 1/2"FJ - 1/4"MJ
21	1	T401140	ELBOW, 1/2"MP - 1/2"MJ
22	1	T000200	SELECTOR VALVE
23	2	T400040	UNION, 1/2"MP - 1/2"MJ
24	1	T402156	TEE, 1/2"MP - 1/2"FP - 1/2"FP
25	3	8041492	HOSE ASSY VAC 8-18 ST-90
26	1	8041494	HOSE ASSY VAC 4-18 ST-90
27	1	8030662	Q.D. MALE DRIPLESS 1/2"
28	1	8030663	Q.D. FEMALE DRIPLESS 1/2"
29	1	8041149	AUX HYD CONSOLE - MTG PLATE
30	1	HM00092	PRESSURE GUAGE
31	2	T400396	BULKHEAD, 1/2"MP - 1/2"MJ
32	1	T401160	ELBOW 90 DEG 3/4"MNPT - 1/2"MJ
*	1	J200002	DECAL SHEET

* NOT SHOWN

072808

VACASSY953

EXTENSION ARM

BOOM

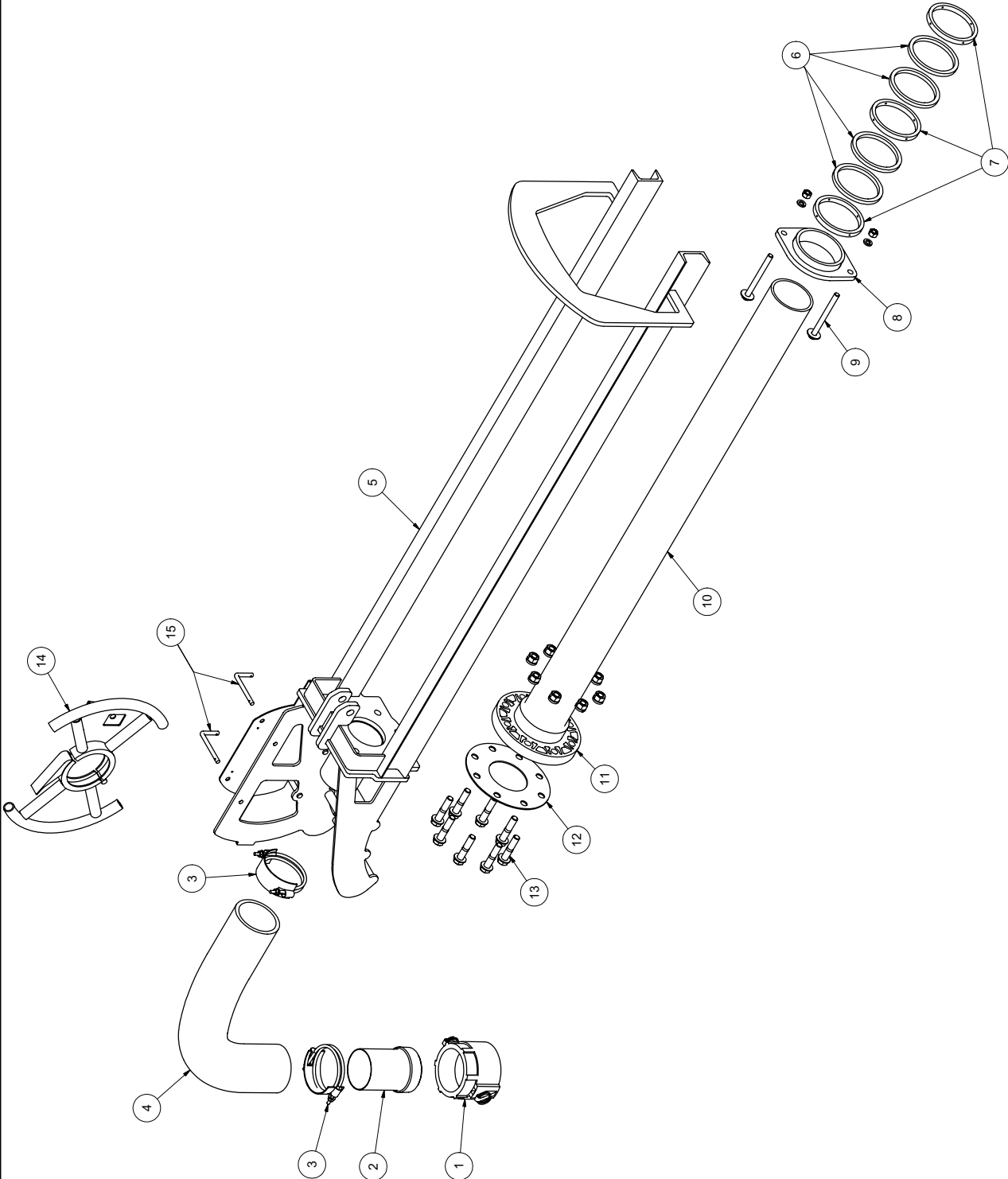

091109-E

VACASSY970

EXTENSION ARM

BOOM

ITEM	QTY	NUMBER	DESCRIPTION
1	1	8030846	4" FEMALE COUPLER
2	1	8045239	UNION EXHAUST 4" OD-MNPT
3	2	8042606	CLAMP T-BOLT 450
4	1	8045800	HOSE VAC AG SUCTION 4-18
5	1	8041960	EXTENSIONARM
6	4	8041947	PACKING RING
7	3	8041945	PLASTIC SLEEVE
8	1	8041963	PACKING GLAND
9	2	U001020	SCREW HC 1/2-13 X 5.50
	2	U200100	WASHER FLAT 1/2"
	2	U210100	WASHER LOCK 1/2"
	2	U100120	NUT HEX 1/2-13
10	1	8042160	4" PVC TUBE X 60" LONG
11	1	8041937	4" PVC FLANGE
12	1	8041938	GASKET
13	8	U001250	SCREW HC 5/8-11 X 3.00
	8	U200140	WASHER FLAT 5/8"
	8	U210140	WASHER LOCK 5/8"
	8	U100180	NUT HEX 5/8-11
14	1	8043647	BOOM HANDLE
	2	8042971	RUBBER STRIP
15	2	8043947	CAPTURE PIN
	2	R700160	R CLIP
	2	8041485	LANYARD CABLE

PIVOT ARM

BOOM

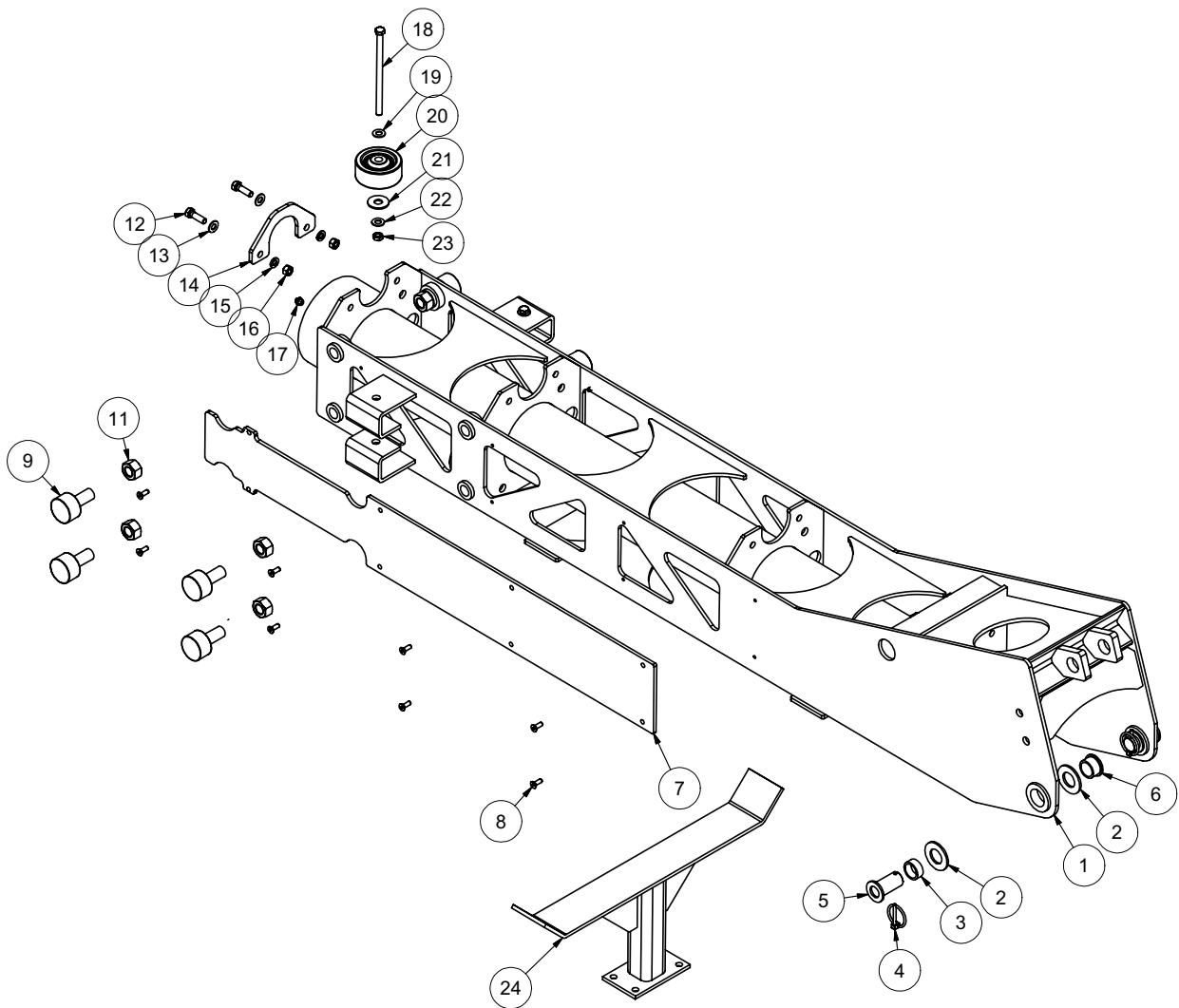

112509-E

VACASSY969

PIVOT ARM

BOOM

ITEM	QTY	NUMBER	DESCRIPTION
1	1	8041950	PIVOT ARM
2	6	U200170	WASHER FLAT 1.0"
3	2	8042101	BUSHING BRONZE 1.25"X1.00"X0.50" PLN
4	10	U340050	PIN LINCH 3/16 X 1-9/16
5	2	8042124	PIN
6	2	8041883	BUSHING BRONZE 1.25"X1.00"X0.63" FLG
7	2	8041986	GLIDE SHEET
8	16	U030015	SCREW SFH .250-20 X .750
9	8	W000050	ROLLER
11	8	U120151	NUT,JAM NYLON LOCK .750-16
12	12	U000440	SCREW HC .375-16 X 1.25
13	2	U200600	WASHER FLAT 3/8"
14	1	8041956	CYLINDER RETAINER
15	2	U210060	WASHER LOCK 3/8"
16	2	U100060	NUT HEX .375-16
17	1	T500100	GREASE FITTING
18	2	U001040	SCREW HC .500-13X6.50
19	2	U200100	WASHER FLAT 1/2"
20	2	8030226	WHEEL
21	2	U200100	WASHER FLAT 1/2"
22	2	U200100	WASHER FLAT 1/2"
23	2	U120120	NUT LOCK .500-13
24	1	8044560	CRADLE, V500 (11 1/4")
	1	8043769	CRADLE, V800-V1200 (8 3/8")

TURRET

BOOM MANUAL ROTATION

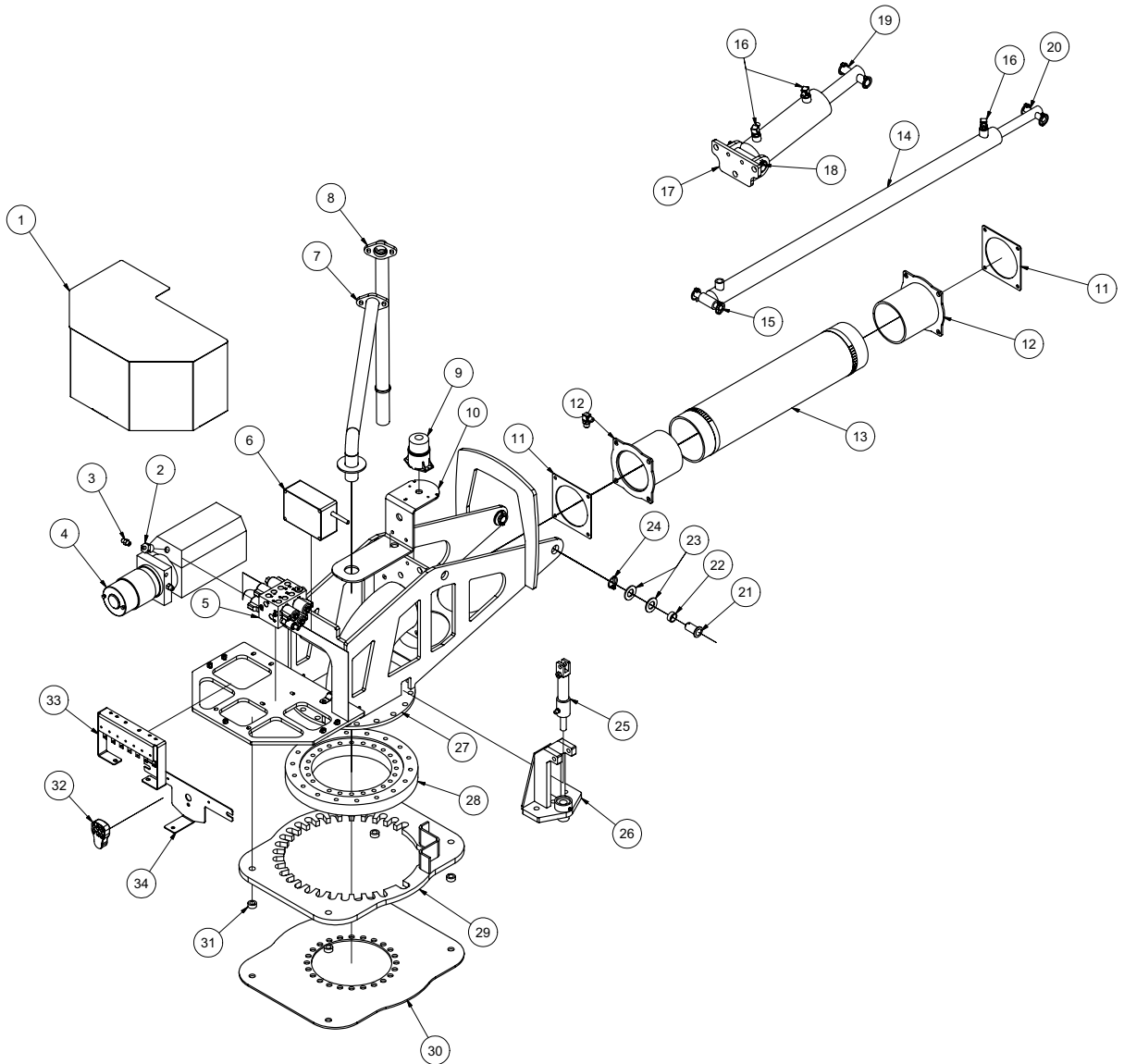

112409-E

VACASSY984

TURRET

BOOM MANUAL ROTATION

ITEM	QTY	PART #	DESCRIPTION
1	1	8043090	BOOM GUARD
2	1	T403018	REDUCER 12MP-4MJ
3	2	T400037	UNION 6MB-6MJ
4	1	8041601	PUMP HYD. 12V 6QT
5	1	8043578	MANIFOLD ASSY BOOM
6	1	8041914	BOOM - RC RECEIVER 6-RELAY
*		8042427	BOOM - RC RECEIVER 8-RELAY
7	1	8043245	BOOM CABLE TUBE WELDMENT
8	1	8045080	BOOM CABLE TUBE VERTICAL WELDMENT
9	1	8043139	STROBE LIGHT
10	1	8041932	BOOM - TURRET STROBE LIGHT PLATE
11	2	8041988	BOOM - FLANGE GASKET
12	2	8041958	BOOM - FLEX HOSE ADAPTER WELDMENT
13	1	8043678	HOSE AG SUCTION 6-30
	2	8042104	HOSE CLAMP 6IN T-BOLT
14	1	8030359	CYLINDER, HYD. 3" X 20" VAC'S
	1	8043782	HYD. HOSE EXTEND 6-77 ST-90
	1	8043783	HYD. HOSE RETRACT 6-114 ST-90
15	1	8042122	BOOM - EXT. CYLINDER BASE PIN
	2	U340050	PIN LINCH 3/16 X 1 9/16"
16	4	T401270	ELBOW, 90 1/2"MB - 3/8"MJ
17	1	8042887	AJUSTABLE CLEVIS - BOOM
18	1	8041977	BOOM - PIVOT CYLINDER BASE PIN
	2	U340050	PIN LINCH 3/16 X 1 9/16"
19	1	8041990	BOOM - PIVOT CYLINDER ROD PIN
	2	U340050	PIN LINCH 3/16 X 1 9/16"
20	1	8042350	BOOM - EXT. CYLINDER RD PIN
	2	U340050	PIN LINCH 3/16 X 1 9/16"
21	2	8042124	BOOM - TURRET PIVOT PIN
22	2	8042101	BUSHING BRONZE 1.25" X 1.00" X .50"LG
23	4	U200170	WASHER, FLAT 1"
24	2	U340050	PIN LINCH 3/16 X 1 9/16"
25	1	8043052	BRAKE CYLINDER
	1	T400801	PLUG, BREATHER 1/4"NPT
	1	T402020	UNION 4MJ-4MP
26	1	8045157	BOOM MANUAL BRAKE WELDMENT
	1	T500080	FITTING, GREASE 3/16"
27	1	8042240	BOOM - TURRET WELDMENT
	2	8041686	GROMMET 1"ID - 1 1/4"DOG - 1/4"WO
	6	U001281	SCREW, HC .625 - 11 X 3.50"
	6	U120020	NYLON LOCK NUT .625-11
	12	U200140	WASHER FLAT .625
28	1	8042234	SWIVEL BEARING
*	3	T500020	FITTING, GREASE. 125 STRAIGHT (2 FITTINGS IN INNER RING, 1 IN OUTER RING)
29	1	8045195	BOOM MOUNT BRAKE RING
30	1	8043021	BOOM - LOWER STOP DISC
31	4	8030315	SKID - WATER TANK CLEVIS TUBE
32	1	8042426	RC TRANSMITTER (w/ GRAPHIC OVERLAYS)
*	1	X200006	BOOM WIRING HARNESS
*	1	8041911-1	RUBBER 6-BUTTON PAD
*	1	8043075	DECAL OVERLAY
*		8042428	RC TRANSMITTER 8 BUTTON (w/ GRAPHIC OVERLAYS)
33	1	8043639	BRACKET BOOM ELECTRONIC
	7	X000320	DEUTSCH DIODE RECEPTACLE
	1	8040185	RELAY
	2	8043690	TIME RELAY 2 SEC N/C
34	1	8044553	WORK LIGHT W/ DUETSCH CONNECTOR BUILT BRACKET

BOOM MANIFOLD CAVITY IDENTIFICATION

PORT	PART#	DESCRIPTION	USED ON
1.1	8043584	3-WAY VALVE	ALL
1.2	8043584	3-WAY VALVE	ALL
1.3	8043584	3-WAY VALVE	ALL
1.4	8043584	3-WAY VALVE	ALL
3.2	8043586	CHECK VALVE	MANUAL ROTATION
4.2	8042302	PRESSURE SWITCH 1000 PSI, N/C	MANUAL ROTATION
5	8043587	RELIEF VALVE ADJ	ALL
7	8043585	2-WAY VALVE N/O	MANUAL ROTATION

* NOT SHOWN

112409-E

VACASSY984

TURRET

BOOM MANUAL ROTATION REV. FLOW

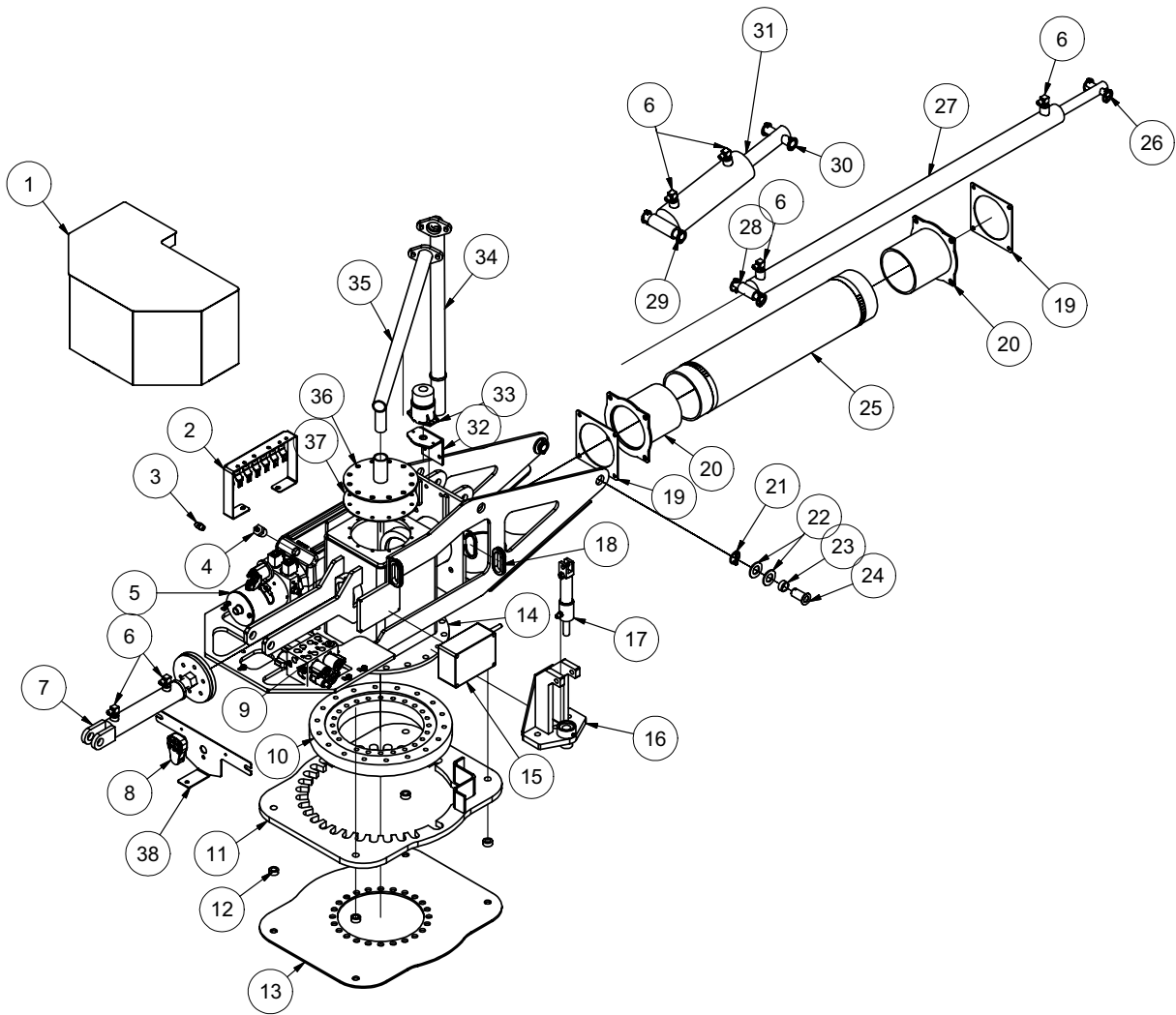

112409-E

VACASSY985

TURRET

BOOM MANUAL ROTATION REV. FLOW

ITEM	QTY	PART #	DESCRIPTION	ITEM	QTY	PART #	DESCRIPTION
1	1	8043090	BOOM GUARD	28	1	8042122	BOOM - EXT. CYL. BASE PIN
2	1	8043639	BRACKET BOOM ELECTRONIC	29	1	8041977	BOOM - PIVOT CYL. BASE PIN
	7	X000320	DEUTSH DIODE RECEPTACLE	30	1	8041990	BOOM - PIVOT CYL. ROD PIN
	1	8040185	RELAY	31	1	8042887	ADJUSTABLE CLEVIS - BOOM
	2	8043690	TIME RELAY	32	1	8045191	STROBE LIGHT PLATE
3	2	T400037	UNION 6MB-6MJ	33	1	8043139	STROBE LIGHT
4	1	T403018	REDUCER 12MP-4MJ	34	1	8045080	BOOM CABLE TUBE VERTICAL
5	1	8045355	PUMP, HYD. 12V VAC 6QT	35	1	8044504	BOOM CABLE EXT. HORZ.
6	6	T401270	ELBOW, 90 1/2"MB - 3/8"MJ	36	1	8044507	CLEANOUT COVER BOOM WELD'T
7	1	8041327	CYLINDER, HYD. DOOR & REV FLOW	12		U000420	SCREW, HC 3/8"-16 X 1"
	2	W201020	WIPER, CYLINDER ROD, 1 1/8" ROD	12		U210060	WASHER, LOCK 3/8"
	1	8044480	SEAL PLATE WELDMENT	12		U200600	WASHER, FLAT 3/8"
	1	8044482	BOOM SHUTOFF SEAL	37	1	8044475	BOOM TURRET SHUTOFF - CLEANOUT COVER GASKET
	1	8044483	BOOM SHUTOFF SEAL PLATE SHIELD	38	1	8044553	WORK LIGHT W/ DUETSCH CONNECTOR BUILT BRACKET
	1	U001570	SCREW, HC 1"-8 X 5.00				
	1	U120060	NUT, LOCK NY 1 - 8				
8	1	8042426	RC TRANSMITTER (w/ GRAPHIC OVERLAYS)				
*	1	8045653	BOOM REMOTE METAL CLIP				
*	1	X200006	BOOM WIRING HARNESS	*	1	X300200	CABLE BATTERY GND 1GA 600"
*	1	8041911-1	RUBBER 6-BUTTON PAD	*	1	X300201	CABLE BATTERY HOT 1GA 600"
*	1	8043075	DECAL OVERLAY				
*		8042428	RC TRANSMITTER 8 BUTTON				
9	1	8043580	MANIFOLD ASSY BOOM	*			NOT SHOWN
10	1	8042234	SWIVEL BEARING				
*	3	T500020	FITTING, GREASE. 125 STRAIGHT (2 FITTINGS IN INNER RING, 1 IN OUTER RING)				
11	1	8045195	BOOM MOUNT BRAKE RING				
12	4	8030315	SKID - WATER TANK CLEVIS TUBE				
13	1	8043021	BOOM - LOWER STOP DISC				
14	1	8045139	BOOM TURRET SHUTOFF WELDMENT				
	6	U001281	SCREW, HC .625-11 X 3.50"	1.1		8043584	3-WAY VALVE ALL
	6	U120020	NYLON LOCK NUT .625-11	1.2		8043584	3-WAY VALVE ALL
	12	U200140	WASHER, FLAT .625	1.3		8043584	3-WAY VALVE ALL
15	1	8041915	BOOM - RC RECEIVER 8-RELAY	1.4		8043584	3-WAY VALVE ALL
		8041916	ANTENNA, BOOM 3" STRAIGHT	1.5		8043584	3-WAY VALVE REVERSE FLOW
16	1	8045157	BOOM MANUAL BRAKE WELD'T	1.6		8043584	3-WAY VALVE REVERSE FLOW
	1	T500080	FITTING, GREASE 3/16"	3.2		8043586	CHECK VALVE MANUAL ROTA-
17	1	8043052	BRAKE CYLINDER				
	1	T400801	PLUG, BREATHER 1/4"NPT	4.2		8042302	PRESSURE SWITCH MANUAL ROTATION 1000 PSI, N/C
	1	T402020	UNION 4MJ-4MP				
18	2	8042812	GROMMET 2"ID3"OD 1/4"WOG	5		8043587	RELIEF VALVE ADJ ALL
19	2	8041988	BOOM FLANGE GASKET	7		8043585	2-WAY VALVE N/O MANUAL ROTA-
20	2	8041958	BOOM - FLEX HOSE ADAPTER WELD'T				
21	10	U340050	PIN LINCH 3/16" X 1 9/16"				
22	4	U200170	WASHER, FLAT 1"				
23	2	8042101	BUSHING BRONZE 1.25" X 1.00" X .50"LG				
24	2	8042124	BOOM - TURRET PIVOT PIN				
25	1	8043678	HOSE AG SUCTION 6-30				
	2	8042104	HOSE CLAMP 6IN T-BOLT				
26	1	8042350	BOOM - EXT. CYLINDER ROD PIN				
27	1	8030359	CYLINDER, HYD 3" X 20" VAC'S				
	1	8043782	HYD. HOSE EXTEND 6-77 ST-90				

112409-E

VACASSY985

TURRET

BOOM HYDRAULIC ROTATION

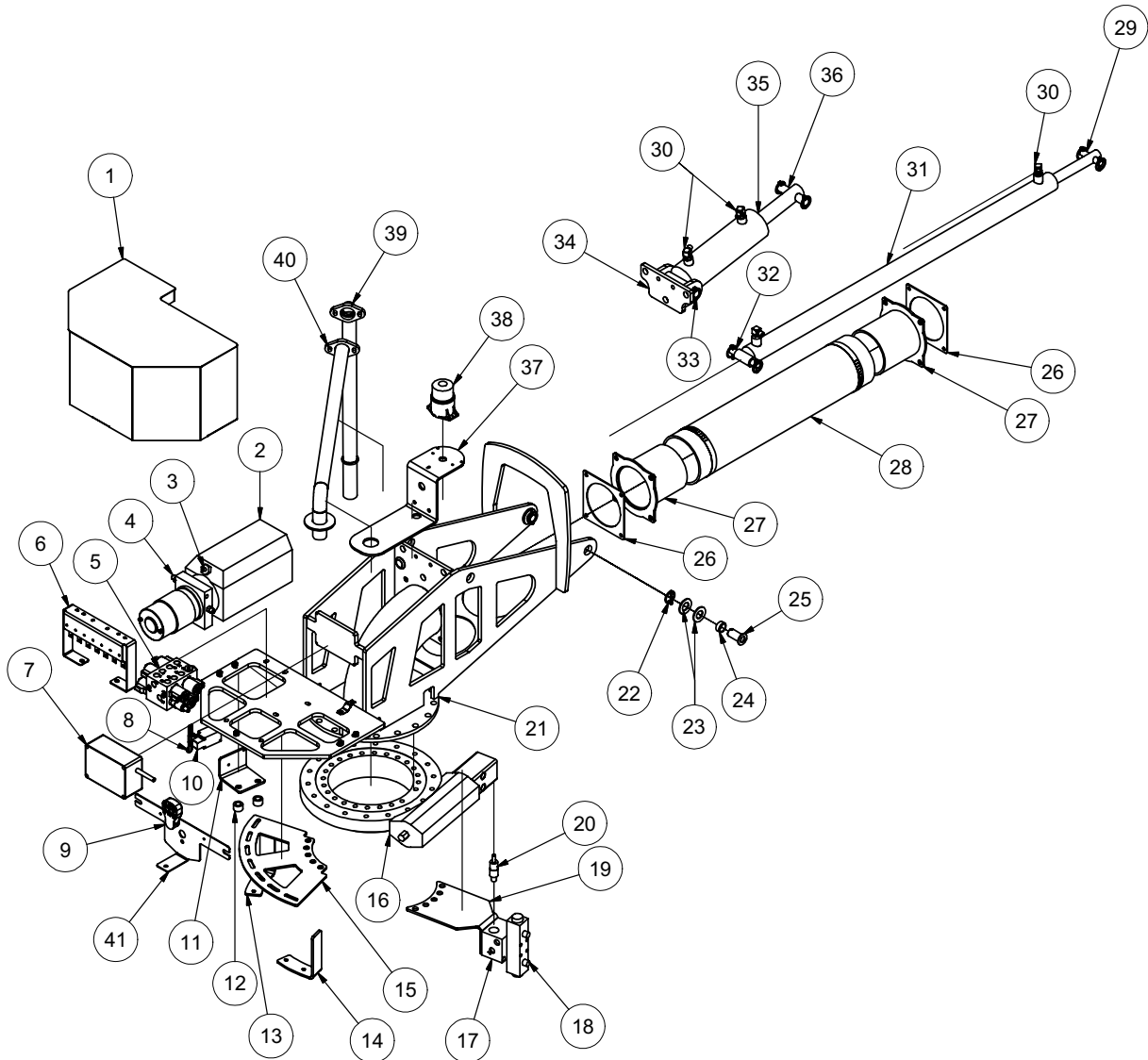

112409-E

VACASSY986

TURRET

BOOM HYDRAULIC ROTATION

ITEM	QTY	PART #	DESCRIPTION
1	1	8043090	BOOM GUARD
2	1	8041601	PUMP HYD. 12V 6QT
3	1	T403018	REDUCER 12MP-4MJ
4	2	T400037	UNION 6MB-6MJ
5	1	8043674	BOOM MANIFOLD
	4	8043584	3-WAY VALVE
6	1	8043639	BRACKET BOOM ELECTRONICS
7	1	8041914	BOOM - RC RECEIVER 6-RELAY
*		8042427	BOOM - RC RECEIVER 8-RELAY
8	1	8042432	LIMIT SWITCH ADJ LOWER
9	1	8042426	RC TRANSMITTER (w/GRAPHIC)
*	1	X200006	BOOM WIRING HARNESS
*	1	8041911-1	RUBBER 6-BUTTON PAD
*	1	8041922	DECAL OVERLAY
*		8042428	RC TRANSMITTER 8-BUTTON (w/GRAPHIC)
10	1	8042431	LIMIT SWITCH (LEVER NOT INCLUDED)
11	1	8042360	BOOM - LIMIT SWITCH BRACKET
12	2	8042376	BOOM - LIMIT SWITCH BRACKET SPACER
13	1	8042357	BOOM - ROTATION STOP BRACKET
14	1	8042359	BOOM - ROTATION STOP BRACKET (OPP)
15	1	8042351	BOOM - ROTATION STOP BASE PLATE
16	1	8042231	SLEW DRIVE - ASSEMBLY
*	3	T500020	FITTING,GREASE.125 STRAIGHT (2 FITTINGS IN INNER, 1 IN OUTER RING)
17	1	8041974	VALVE MANIFOLD BOOM HYD. ROT.
18	1	8041971	VALVE DIRECTIONAL BOOM HYD. ROT.
19	1	8042344	TANK - BOOM HYD. MANIFOLD MTG PLATE
20	1	8041973	VALVE RELIEF BOOM HYD ROT.
21	1	8042240	BOOM - TURRET WELDMENT
22	2	U340050	PIN LINCH 3/16" X 1 9/16"
23	4	U200170	WASHER, FLAT 1"
24	2	8042101	BUSHING BRONZE 1.25" X 1.00" X .50"LG
25	2	8042124	BOOM - TURRET PIVOT PIN
26	2	8041988	BOOM - FLANGE GASKET
27	2	8041958	BOOM - FLEX HOSE ADAPTER WELDMENT
28	1	8043678	HOSE AG SUCTION 6-30
	2	8042104	HOSE CLAMP 6IN T-BOLT
29	1	8042350	BOOM - EXT. CYLINDER PIN
	2	U340050	PIN LINCH 3/16" X 1 9/16"
30	4	T401270	ELBOW, 90 1/2"MB - 3/8"MJ
31	1	8030359	CYLINDER, HYD 3" X 20' VAC'S
	1	8043782	HYD. HOSE EXTEND 6-77 ST-90
	1	8043783	HYD. HOSE RETRACT 6-114 ST-90
32	1	8042122	BOOM - EXT. CYLINDER BASE PIN
	2	U340050	PIN LINCH 3/16" X 1 9/16"
33	1	8041977	BOOM - PIVOT CYLINDER BASE PIN
	2	U340050	PIN LINCH 3/16" X 1 9/16"
34	1	8042887	ADJUSTABLE CLEVIS - BOOM
35	1	8030359	BOOM - CYLINDER SHORT BASE END
36	1	8041990	BOOM - PIVOT CYLINDER ROD PIN
37	1	8041932	BOOM - TURRET STROBE LIGHT PLATE
38	1	8043139	STROBE LIGHT
39	1	8045080	BOOM CABLE TUBE VERTICAL WELDMENT
40	1	8043245	BOOM CABLE TUBE WELDMENT
41	1	8044553	WORK LIGHT W/ DUETSCH CONNECTOR BUILT BRACKET

BOOM MANIFOLD CAVITY IDENTIFICATION			
PORT	PART#	DESCRIPTION	USED ON
1.1	8043584	3-WAY VALVE	ALL
1.2	8043584	3-WAY VALVE	ALL
1.3	8043584	3-WAY VALVE	ALL
1.4	8043584	3-WAY VALVE	ALL
5	8043587	RELIEF VALVE ADJ	ALL

TURRET

BOOM HYDRAULIC ROTATION REV. FLOW

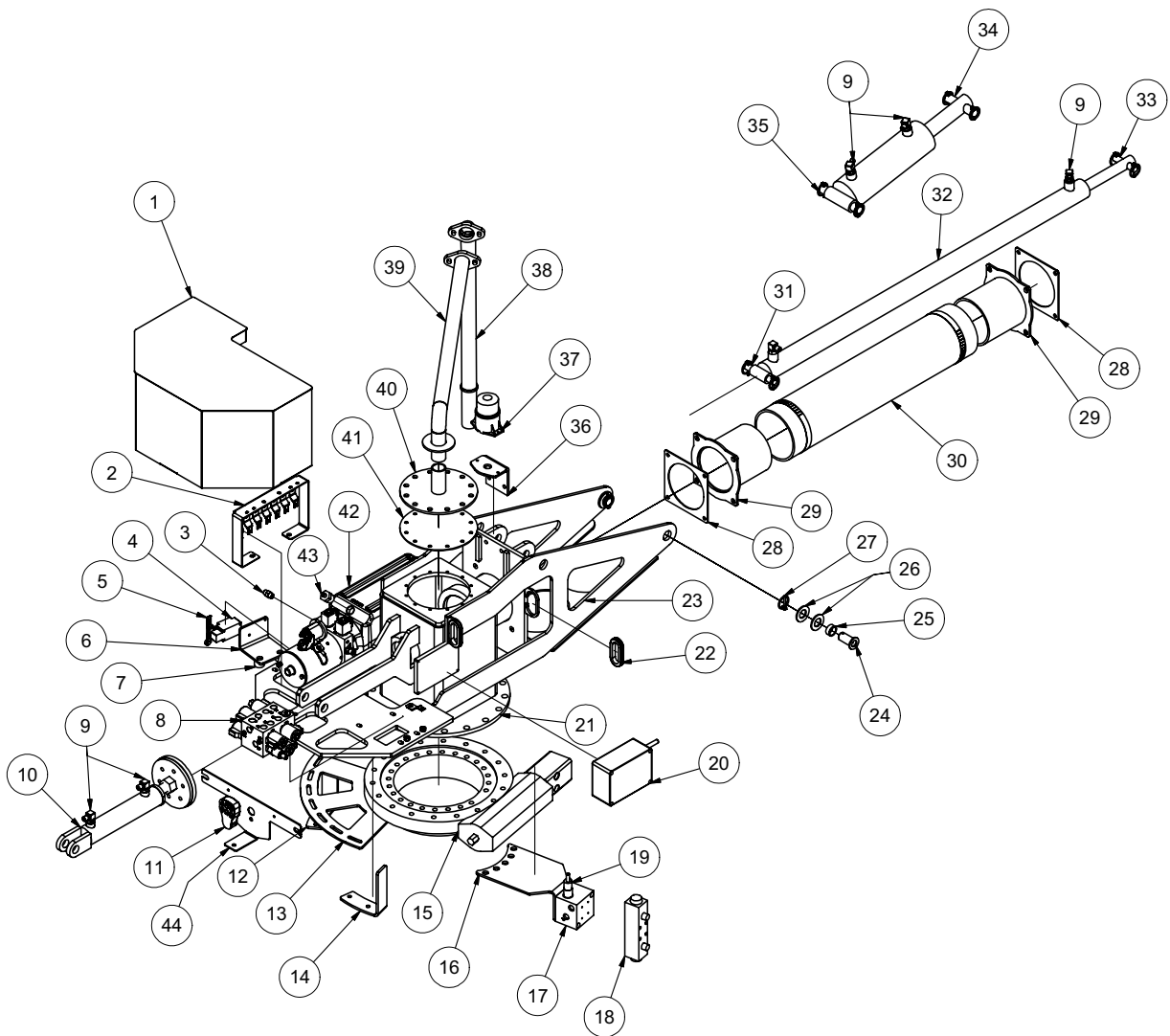

112409-E

VACASSY987

TURRET

BOOM HYDRAULIC ROTATION REV. FLOW

ITEM	QTY	PART #	DESCRIPTION	ITEM	QTY	PART #	DESCRIPTION
1	1	8043090	BOOM GUARD	33	1	8042350	BOOM EXT CYLINDER ROD PIN
2	1	8043639	BRACKET BOOM ELECTRONICS	2	U340050	PIN LINCH 3/16" X 1 9/16"	
	7	X000320	DEUTSH DIODE RECEPTACLE	34	1	8041990	BOOM PIVOT CYLINDER ROD PIN
	1	8040185	RELAY	2	U340050	PIN LINCH 3/16" X 1 9/16"	
	2	8043690	TIME RELAY	35	1	8041977	BOOM PIVOT CYLINDER BASE PIN
3	2	T400037	UNION 6MB-6MJ	2	U340050	PIN LICH 3/16" X 1 9/16"	
4	1	8042431	SWITCH LIMIT BOOM	36	1	8045191	STROBE LIGHT PLATE
5	1	8042432	SWITCH LIMIT BOOM ADJ LEVER	37	1	8043139	STROBE LIGHT
6	1	8042360	BOOM - LIMIT SWITCH BRACKET	38	1	8045080	BOOM CABLE TUBE VERTICAL WELDMENT
7	2	8042376	BOOM - LIMIT SWITCH BRACKET SPACER	39	1	8043245	BOOM CABLE TUBE WELDMENT
8	1	8043580	MANIFOLD ASSY BOOM	40	1	8044507	CLEANOUT COVER BOOM WELDMENT
9	6	T401270	ELBOW, 90 1/2" MB - 3/8" MJ	12	U000420	SCREW, HC 3/8"-16 X 1"	
10	1	8041327	CYLINDER, HYD DOOR & REV FLOW	12	U210060	WASHER, LOCK 3/8"	
	2	W201020	WIPER CYLINDER ROD, 1 1/8" ROD	12	U200600	WASHER, FLAT 3/8"	
	1	8044480	SEAL PLATE WELDMENT	41	1	8044475	BOOM TURRET SHUTOFF CLEANOUT GASKET COVER
	1	8044482	BOOM SHUTOFF SEAL	42	1	8045355	PUMP, HYD. 12V VAC 6QT
	1	8044483	BOOM SHUTOFF SEAL PLATE SHEILD	43	1	T403018	REDUCER 12MP-4MJ
	1	U001570	SCREW, HC 1"-8 X 5.00"	44	1	8044553	WORK LIGHT W/ DUETSCH CONNECTOR BUILT BRACKET
	1	U120060	NUT, LOCK NY 1-8				
11	1	8042426	RC TRANSMITTER (w/GRAPHIC)				
*	1	8045653	BOOM REMOTE MEDAL CLIP				
*	1	X200006	BOOM WIRING HARNESS				
*		8042428	RC TRANSMITTER 8-BUTTON (w/GRAPHIC)				
*	1	8041912-1	RUBBER 8-BUTTON PAD				
*	1	8041923	DECAL OVERLAY	*		NOT SHOWN	
12	1	8042357	BOOM - ROTATION STOP BRACKET				
13	1	8042351	BOOM - ROTATION STOP BASE PLATE				
14	1	8042359	BOOM - ROTATION STOP BRACKET (OPP)				
15	1	8042231	SLEW DRIVE - ASSEMBLY				
*	3	T500020	FITTING, GREASE. 125 STRAIGHT (2 FITTINGS IN INNER RING, 1 IN OUTER RING)				
16	1	8042344	TANK - BOOM HYD. MANIFOLD MTG PLATE				
17	1	8041974	VALVE MANIFOLD BOOM HYD. ROT.				
18	1	8041971	VALVE DIRECTIONAL BOOM HYD. ROT.				
19	1	8041973	VALVE RELIEF BOOM HYD. ROT.				
20	1	8041914	BOOM - RC RECEIVER 6-RELAY				
*		8042427	BOOM - RC RECEIVER 8-RELAY				
21	1	8045176	BOOM - TURRET SUB-WELD'T REAR				
	6	U001281	SCREW, HC .625-11 X 3.50"	1.1	8043584	3-WAY VALVE	ALL
	6	U120020	NYLON LOCK NUT .625-11	1.2	8043584	3-WAY VALVE	ALL
	12	U200140	WASHER, FLAT .625	1.3	8043584	3-WAY VALVE	ALL
22	2	8042812	GROMMET 2" ID 3" OD 1/4" WOG	1.4	8043584	3-WAY VALVE	ALL
23	1	8045175	BOOM TURRET SUB-WELDMENT	1.5	8043584	3-WAY VALVE	REVERSE FLOW
24	2	8042124	BOOM - TURRET PIVOT PIN	1.6	8043584	3-WAY VALVE	REVERSE FLOW
25	2	8042101	BUSHING BRONZE 1.25" X 1.00" X .50" LG	5	8043587	RELIEF VALVE ADJ	ALL
26	4	U200170	WASHER, FLAT 1"				
27	2	U340050	PIN LINCH 3/8" X 1 9/16"				
28	2	8041988	BOOM - FLANGE GASKET				
29	2	8041958	BOOM - FLEX HOSE ADAPTER WELDMENT				
30	1	8043678	HOSE AG SUCTION 6-30"				
	2	8042104	HOSE CLAMP 6IN T-BOLT				
31	1	8042122	BOOM - EXT. CYLINDER BASE PIN				
	2	U340050	PIN LINCH 3/8" X 1 9/16"				
32	1	8030359	CYLINDER, HYD. 3" X 20" VAC'S				
	1	8043782	HYD. HOSE EXTEND 6-77 ST-90				
	1	8043783	HYD. HOSE RETRACT 6-114 ST-90				

BOOM MANIFOLD CAVITY IDENTIFICATION

PORT	PART#	DESCRIPTION	USED ON
1.1	8043584	3-WAY VALVE	ALL
1.2	8043584	3-WAY VALVE	ALL
1.3	8043584	3-WAY VALVE	ALL
1.4	8043584	3-WAY VALVE	ALL
1.5	8043584	3-WAY VALVE	REVERSE FLOW
1.6	8043584	3-WAY VALVE	REVERSE FLOW
5	8043587	RELIEF VALVE ADJ	ALL

112409-E

VACASSY987

HOSE STORAGE

BOOM

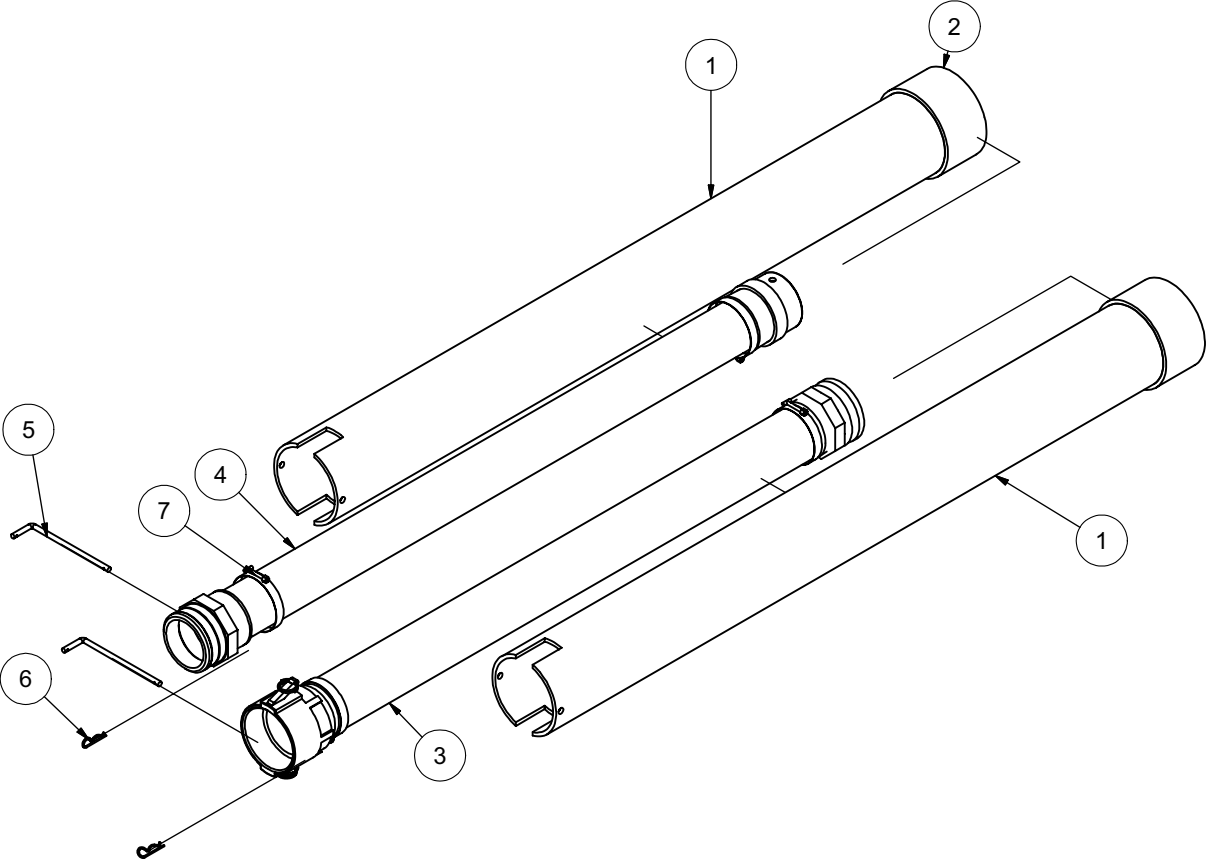

082409-E

VACASSY978

HOSE STORAGE

BOOM

ITEM	QTY	NUMBER	DESCRIPTION
1	2	8042222	BOOM EXTENSION HOSE STORAGE
	2	8043198	CLAMP T-BOLT 700
2	2	8030925	PIPE CAP 6" PVC
3	1	8042137	BOOM HOSE EXTENSION
	1	8041781	BOOM EXTENSION HOSE
4	2	8045239	UNION EXHAUST 4"OD - MNPT
	1	8030846	4" FEMALE COUPLER
	1	8030844	4" MAL COUPLER
	1	8032138	BOOM HOSE EXTENSION WITH 4" UNION PVC
	1	8045723	4" ALUMINUM TUBE 52 1/2" LG
5	2	8045728	4" HALF NIPPLE
	1	8030844	COUPLING, 4" ALUM CAMLOCK MXF
	1	8045725	UNION PVC 4" FNPT 4" MSLIP w/HOLE
	2	8041101	HOSE STORAGE RETAINING ROD
6	2	8041485	LANYARD CABLE
	2	R700160	R-CLIP
7	4	8042606	CLAMP T-BOLT 450

Hot Box Assembly

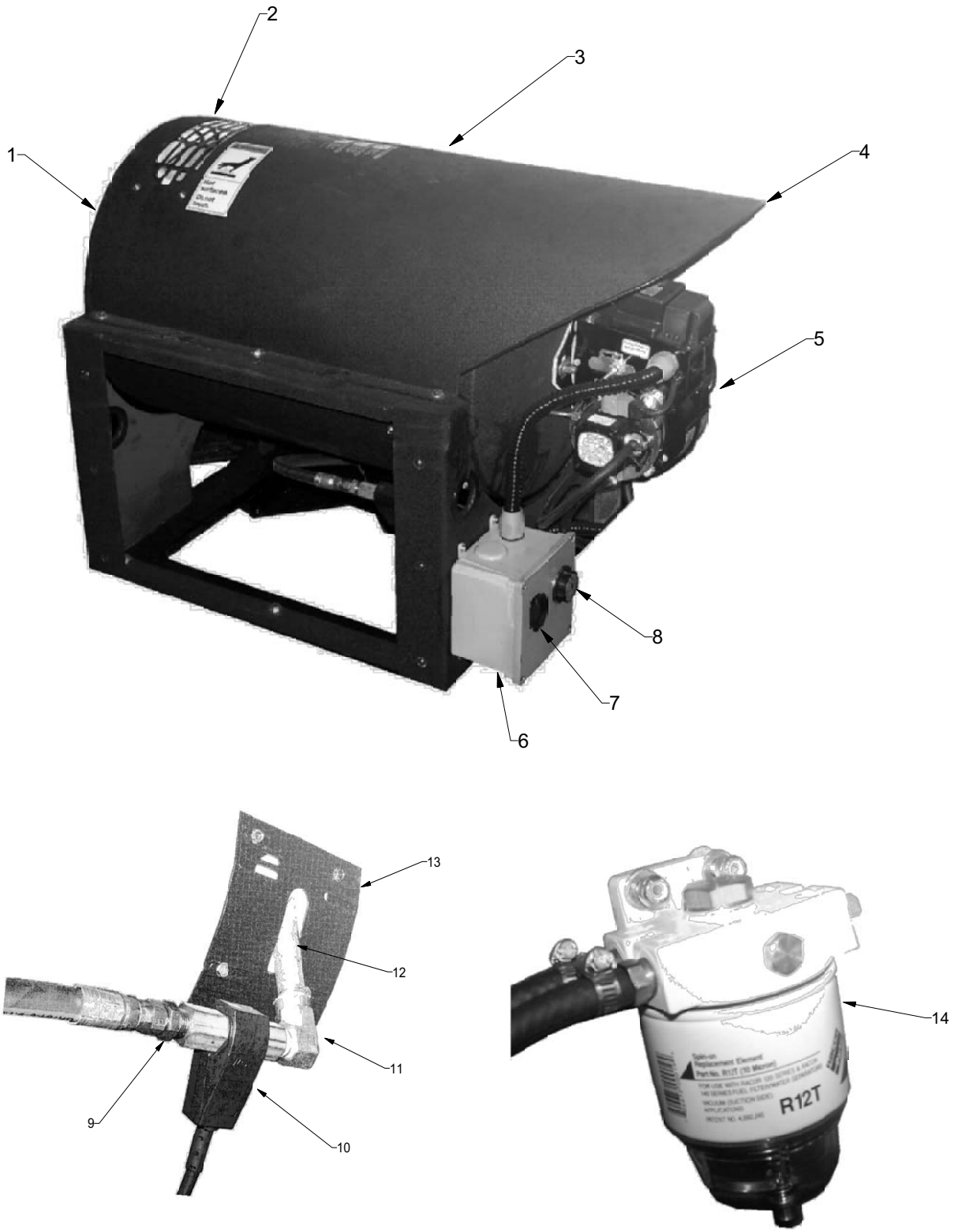

071808

VACASSY949

Hot Box Assembly

ITEM	QTY	NUMBER	DESCRIPTION
1	1	8040088-23	INSULATION DISC
	1	8040088-21	COIL ASSEMBLY
	1	8040088-22	INSULATION BLANKET
	1	8040088-01	INSULATION DRUM HEAD
	1	8040088-20	BOTTOM WRAP ASSEMBLY
2	1	8040088-26	SLOTTED EXHAUST PLATE
	4	8040088-27	CLIP NUT 1/4-2 DUNC
	4	8040088-28	WASHER ZI SAE TYPE A 3/16
	4	8040088-29	SCREW #10-032 X 3/4 LONG
3	1	8040088-25	TOP WRAP
4	1	8040088-24	EDGING 3 FT REQUIRED
5	1	8040088-03	BURNER-12 VOLT
	1	8040088-02	NOZZLE-OIL
	1	8040088-04	LOCKNUT 1/2-ELECTRICAL
	1	8040088-05	CONDIUT STRAIGHT CONNECTOR
	1	8040088-09	ELBOW 1/4 M 1/4 BARB 90 BRASS
6	1	8040089-39	CONTROL BOX COMPLETE
	1	8040088-33	CONTROL BOX ONLY
	4	8040088-30	STRAIN RELIEF
	1	8040088-34	RELAY CONTROL
7	1	X000143	PLUG, ENCLOSURE 3/4" KNOCKOUT
	1	8040088-36	ROCKER SWITCH 15AMP 24 VOLT
8	1	8040088-17	ADJUSTABLE THERMOSTAT 86-194F
9	2	T400029	REDUCER 1/2 MP - 3/8 MJIC
10	1	8040088-14	FLOW SWITCH
11	1	8040088-13	ELBOW 1/2 F X 3/8 M STEEL
12	2	8040088-12	PIPE NIPPLE 1/2 NPT X 5 1/2 LONG
13	2	8040088-11	PATCH PLATE
	8	8040088-10	SCREW SELF DRILL #10 X 1/2
14	1	8040088-38	FUEL FILTER WITH ELEMENT
	1	8040088-37	FUEL FILTER ELEMENT
*	1	8040088-18	CROSS 1/2 NPT STL
*	1	8040088-19	PRESSURE RELIEF VALVE 4500 PSI

* ITEM NOT SHOWN

Arrow Board Option

ARROW BOARD & DUST COVER
NOT DRAWN TO SCALE

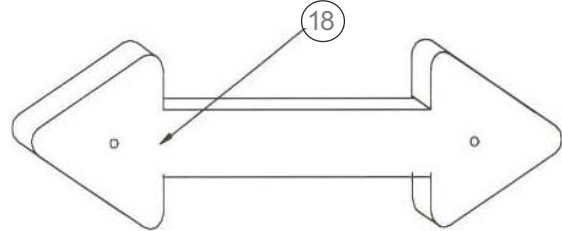
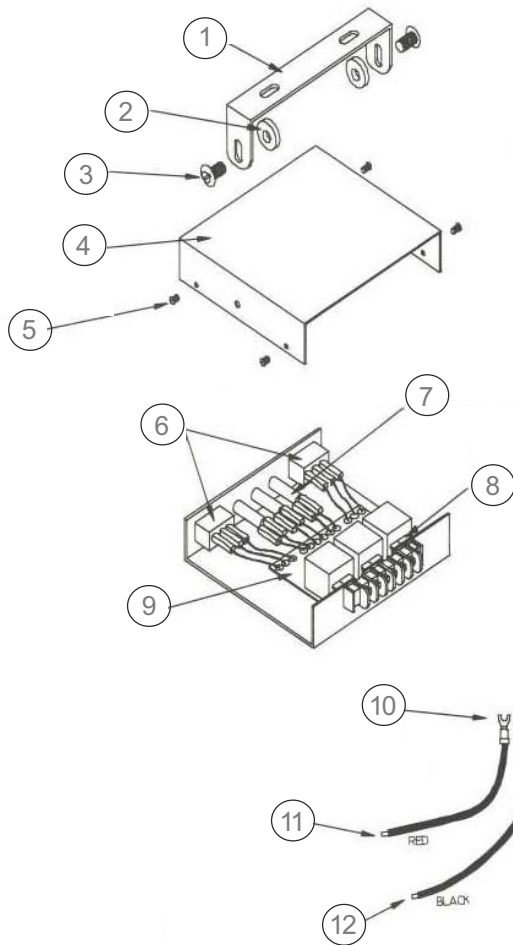

NOTE: MOUNTING BRACKETS MUST BE
ATTACHED TO ARROW BOARD BEFORE
DUST COVER IS REPLACED

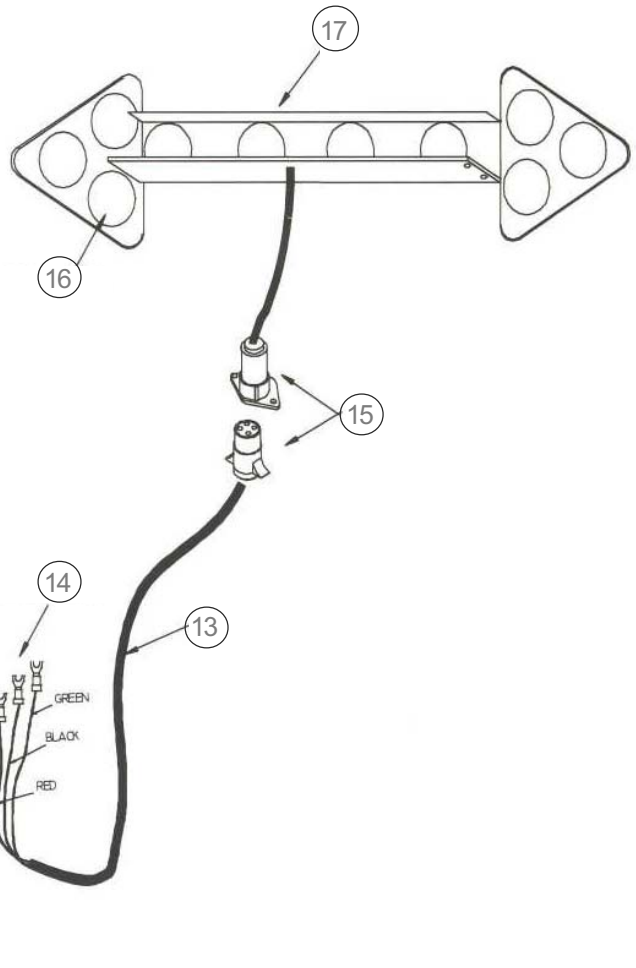

073008

VACASSY947

Arrow Board Option

ITEM	QTY	NUMBER	DESCRIPTION
1	1	8042197-1	MOUNTING BAIL
2	2	8042197-2	WASHER
3	2	8042197-3	BOLT
4	1	8042197-4	COVER
5	4	8042197-5	MACHINE SCREW
6	2	8042197-6	SPDT SWITCH
7	3	8042197-7	RED PILOT LAMP
8	1	8042197-8	15 AMP FUSE
9	1	8042197-9	CIRCUIT BOARD ASSY
10	2	8042197-10	#6 BLUE SPADE CONNECTOR
11	4'	8042197-11	RED
12	4'	8042197-12	BLACK
13	20'	8042197-13	CABLE HARNESS
14	4	8042197-14	#6 BLUE SPADE CONNECTOR
15	1	8042197-15	4-WAY CONNECTOR
16	1	8042197-16	STANDARD LAMP ASSY
17	1	8042197-17	ARROW BOARD FRAME
18	1	8042197-18	DUST COVER

073008

VACASSY947

Vacuum Diesel Engine Schematic

VACUUM DIESEL ENGINE SCHEMATIC

080108

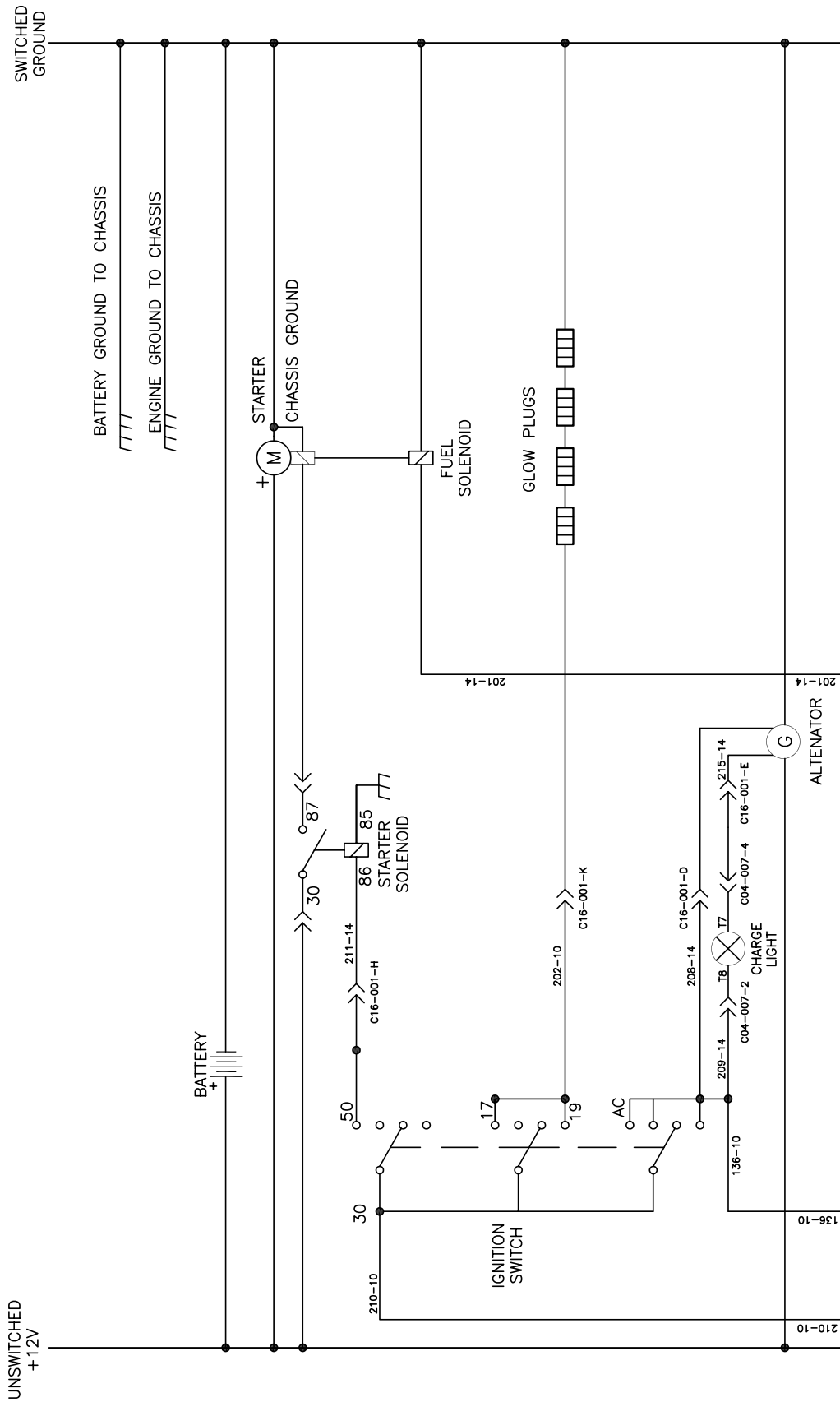

Vacuum Diesel Engine Schematic

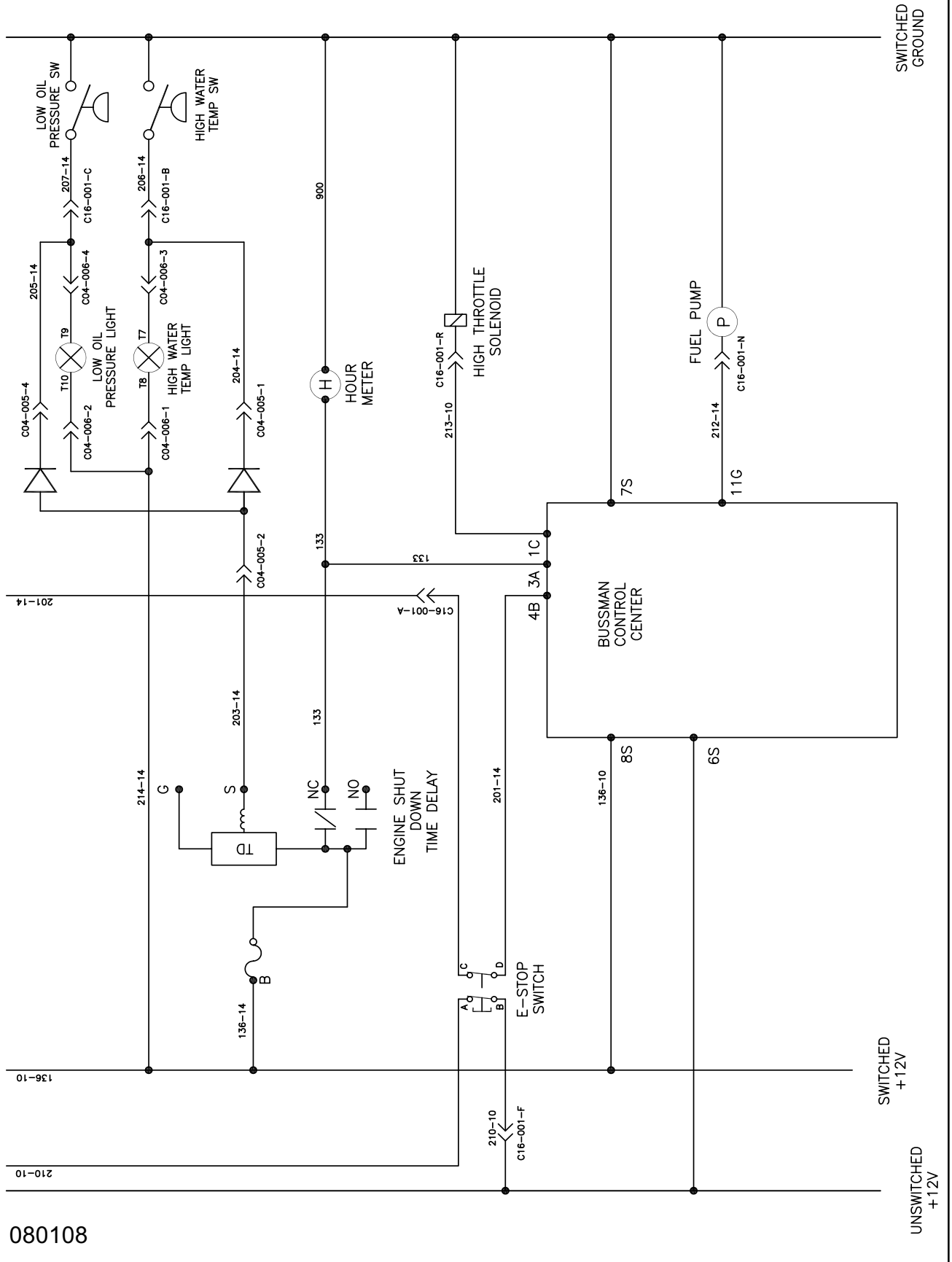

080108

Vacuum Diesel Engine Schematic

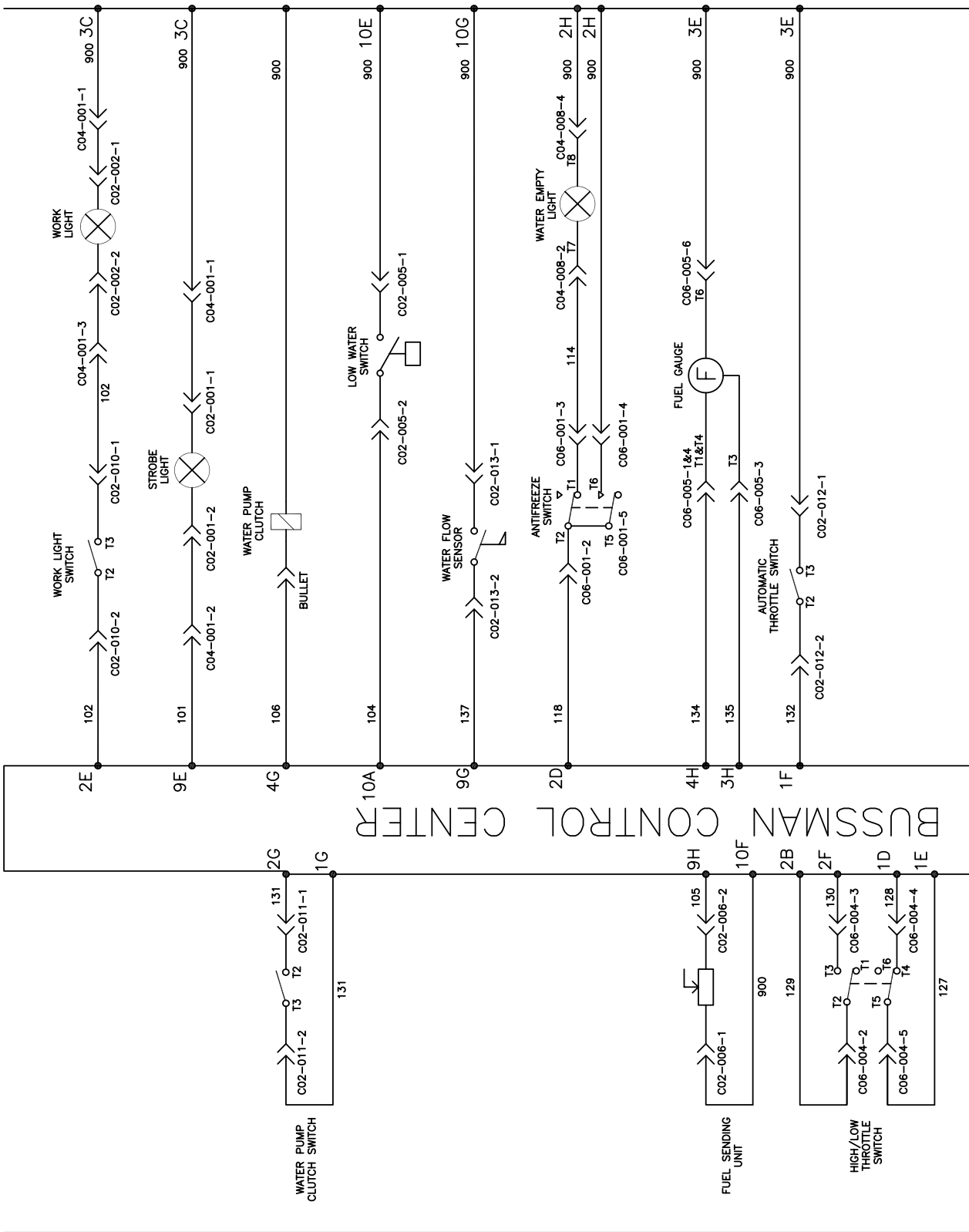

080108

Vacuum Diesel Engine Schematic

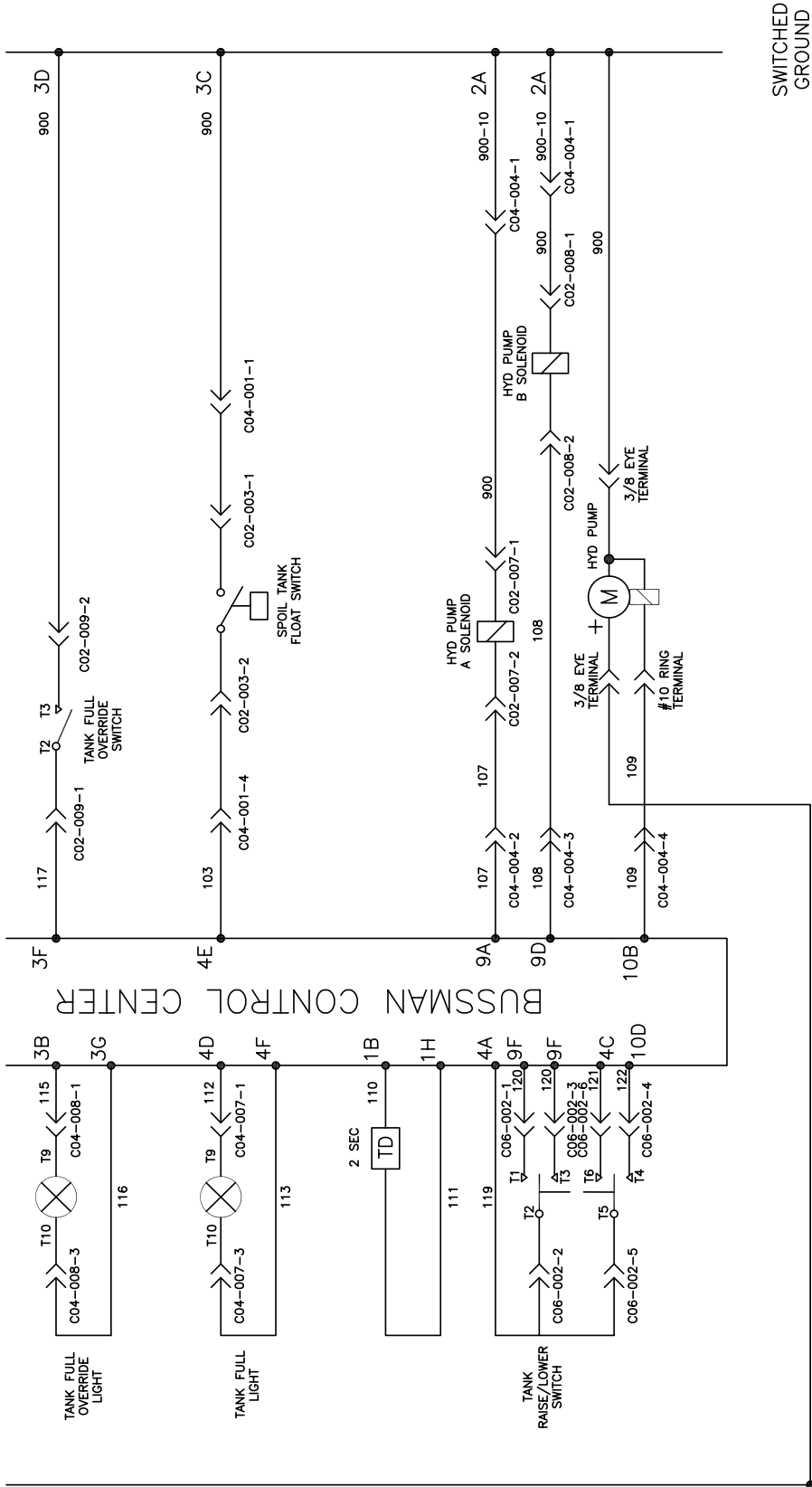

080108

Vacuum Diesel Engine Schematic

BUSSMAN CONTROL CENTER OPTIONS

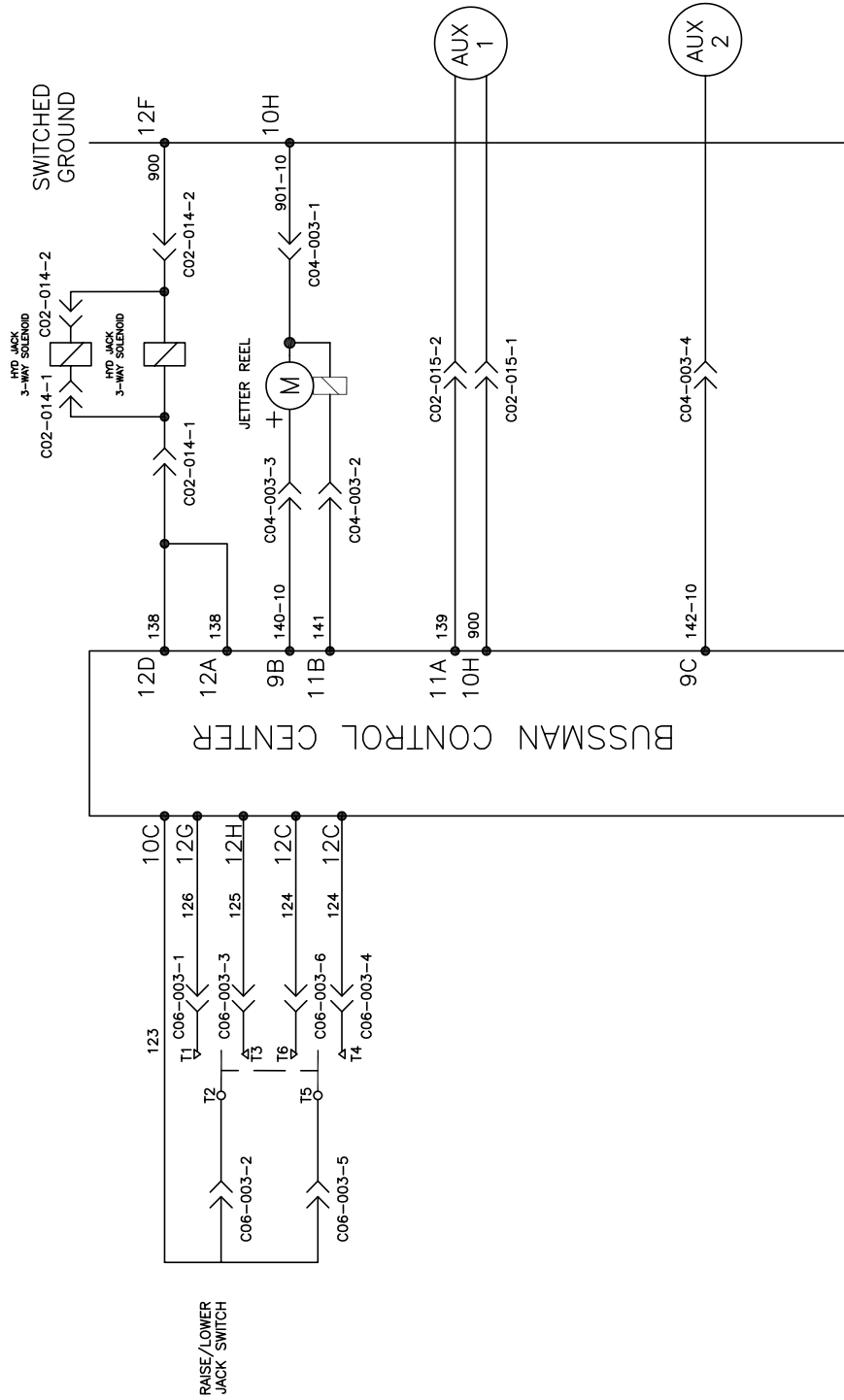

PAGE LEFT BLANK

Boom Wiring Schematic

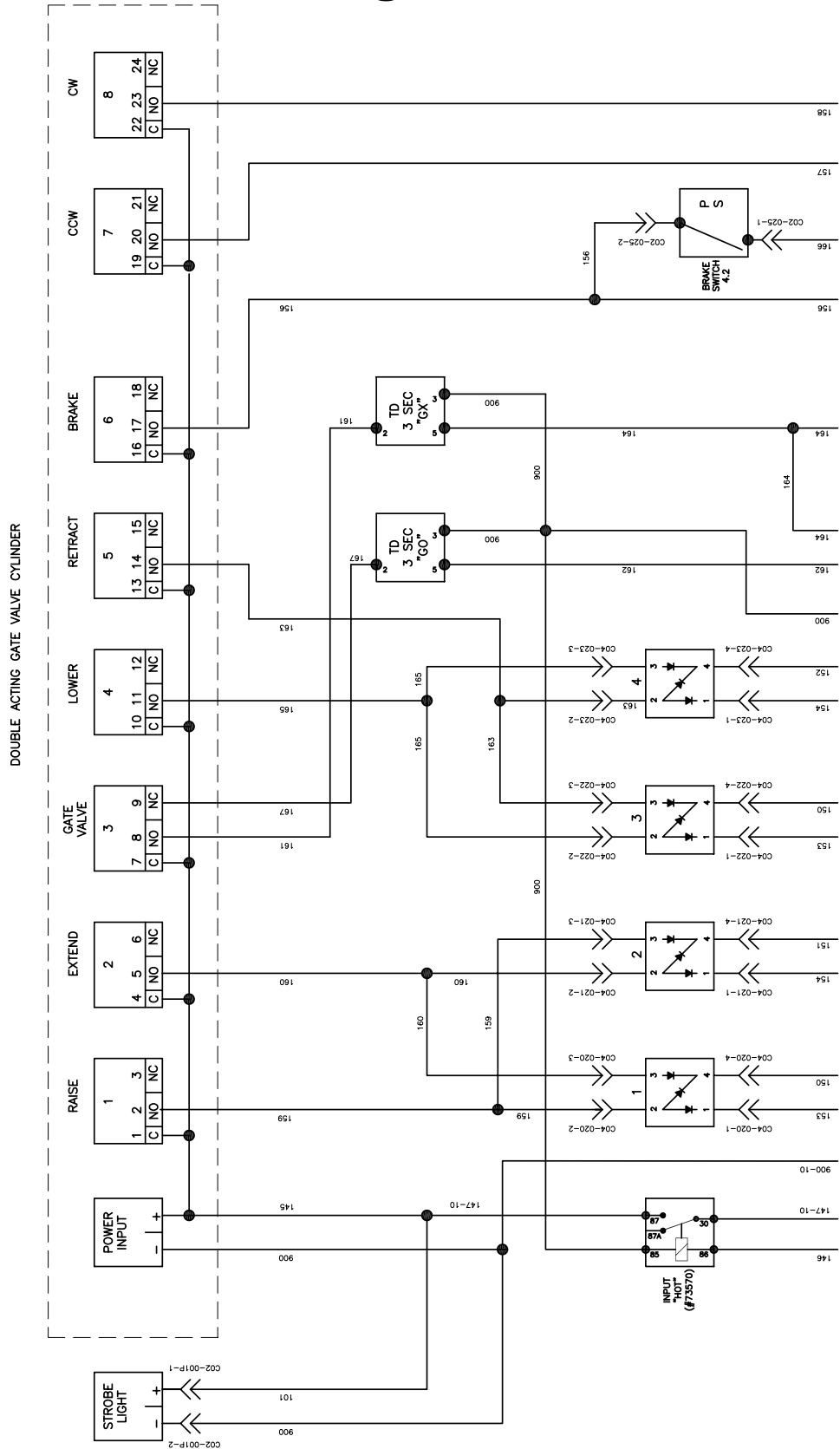

080108

Boom Wiring Schematic

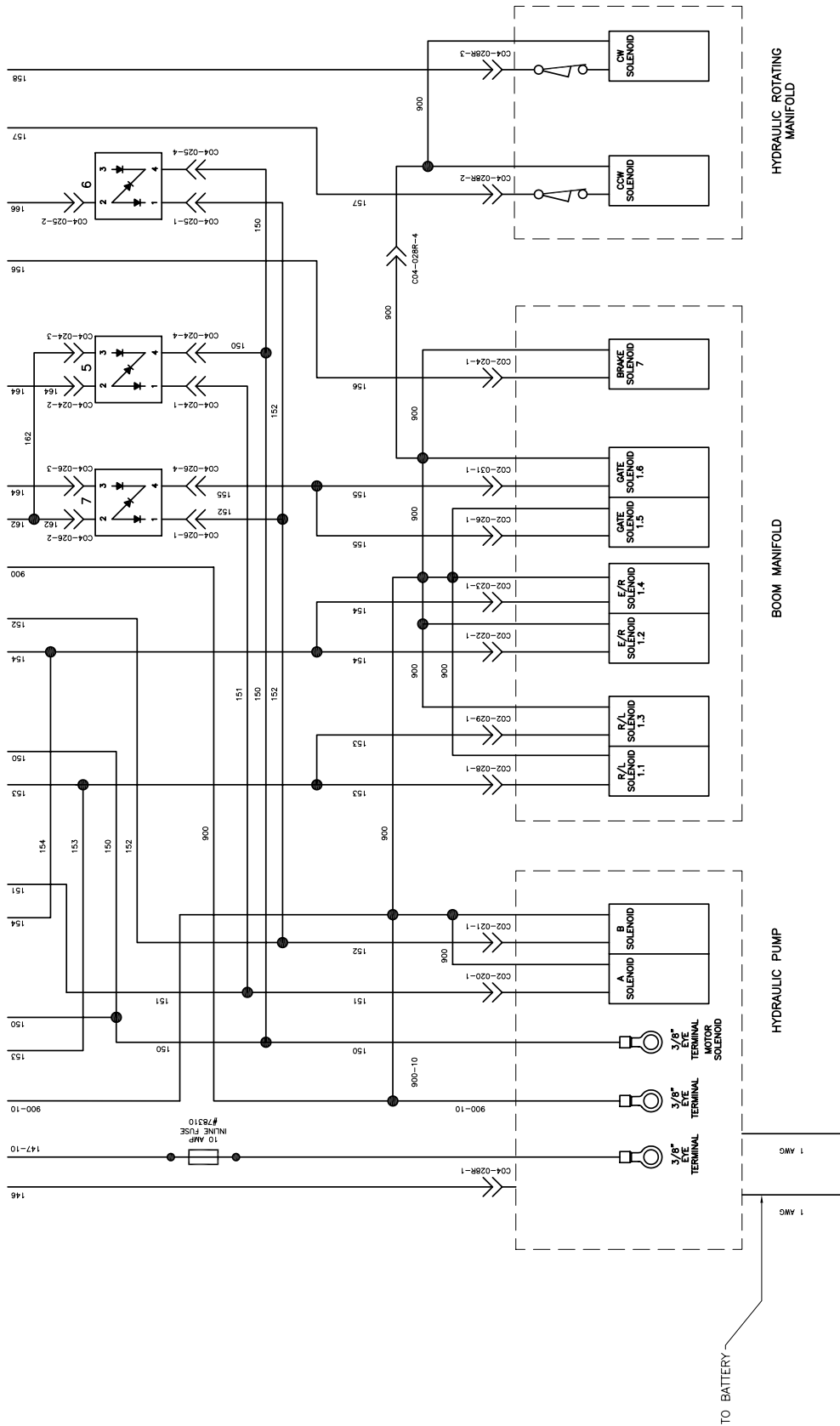

080108

PAGE LEFT BLANK

Hot Box Assembly

WIRING SCHEMATIC

- R1-RELAY #1
- M1-BLOWER MOTOR
- FS-1-FLOW SWITCH
- T1-TEMP SWITCH
- S1-FUEL SOLENOID
- RT1-REMOTE THERMOSTAT CONTROL

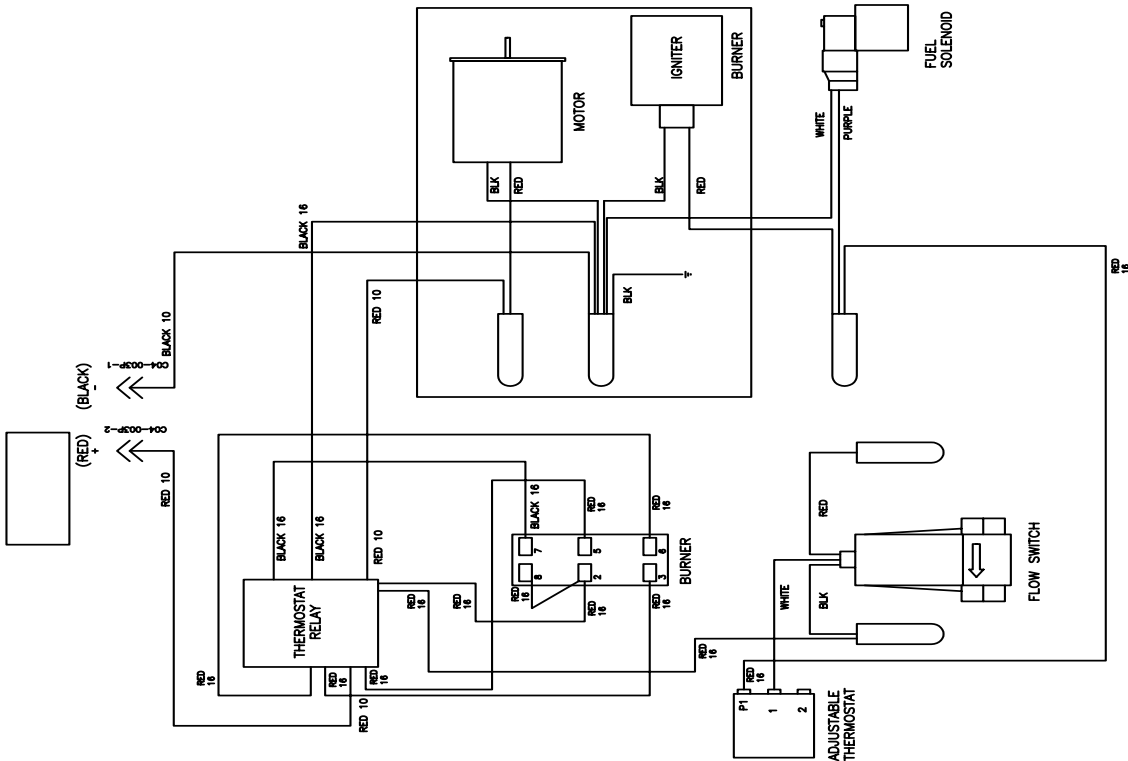
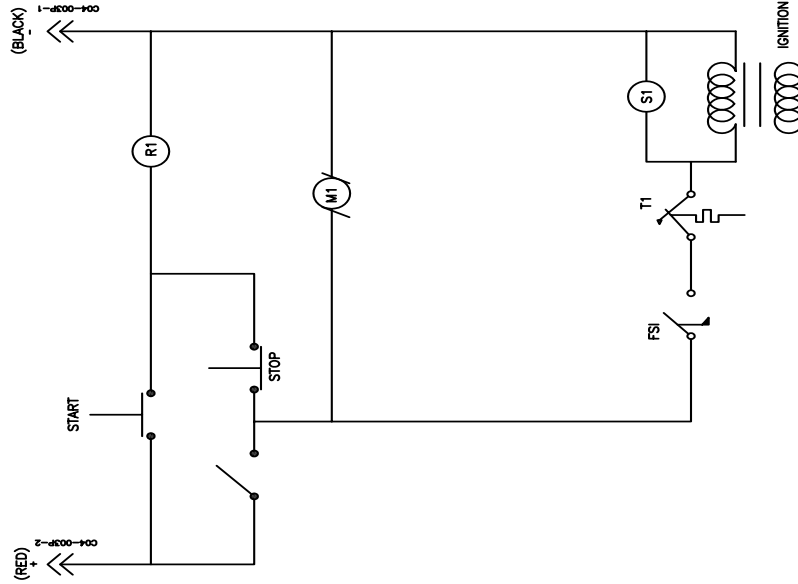

HOT BOX WIRING SCHEMATIC

071808

VACASSY949

PAGE LEFT BLANK

Arrow Board Option

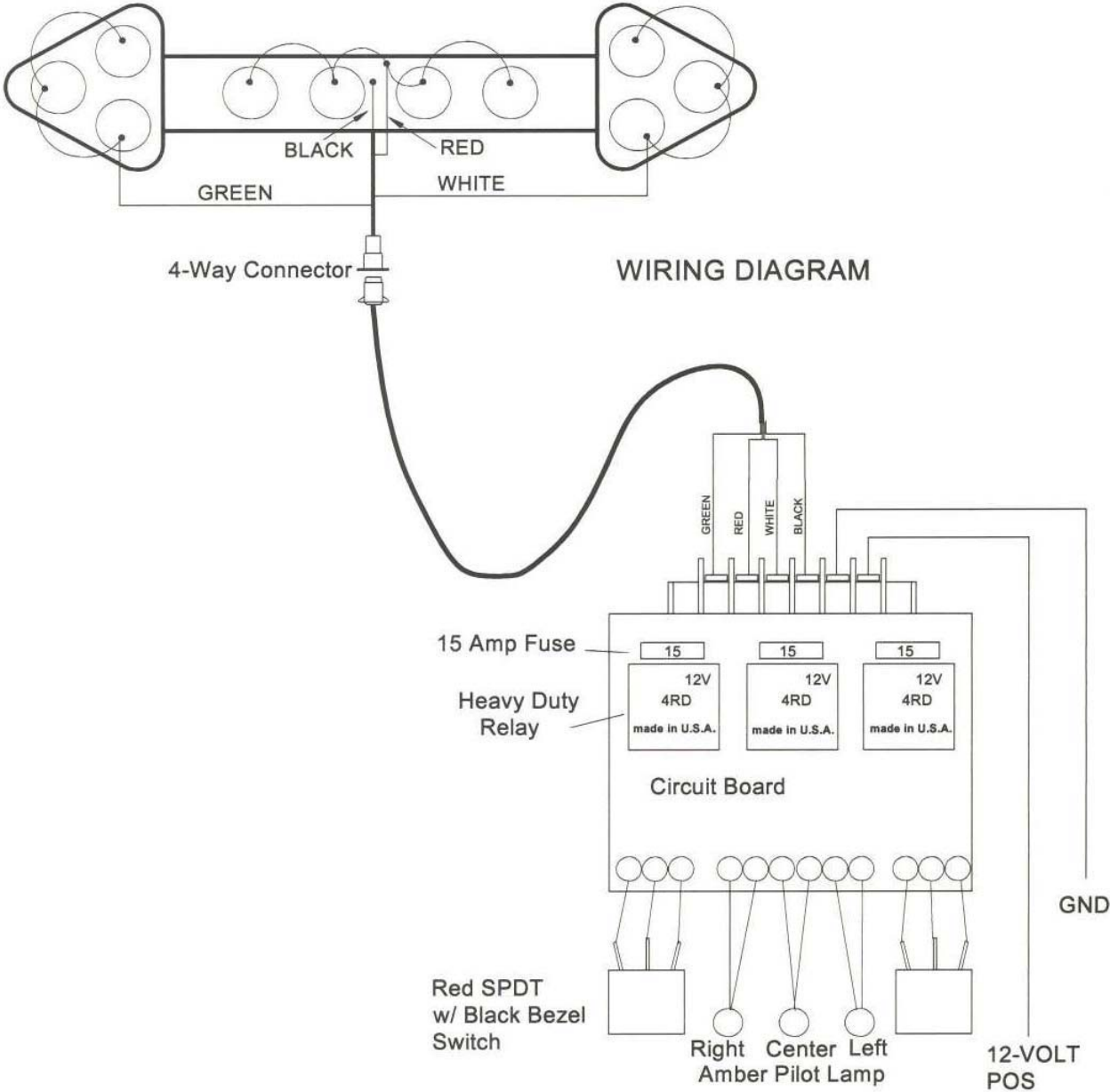

PAGE LEFT BLANK

Tank and Optional Jack Hydraulic Schematic

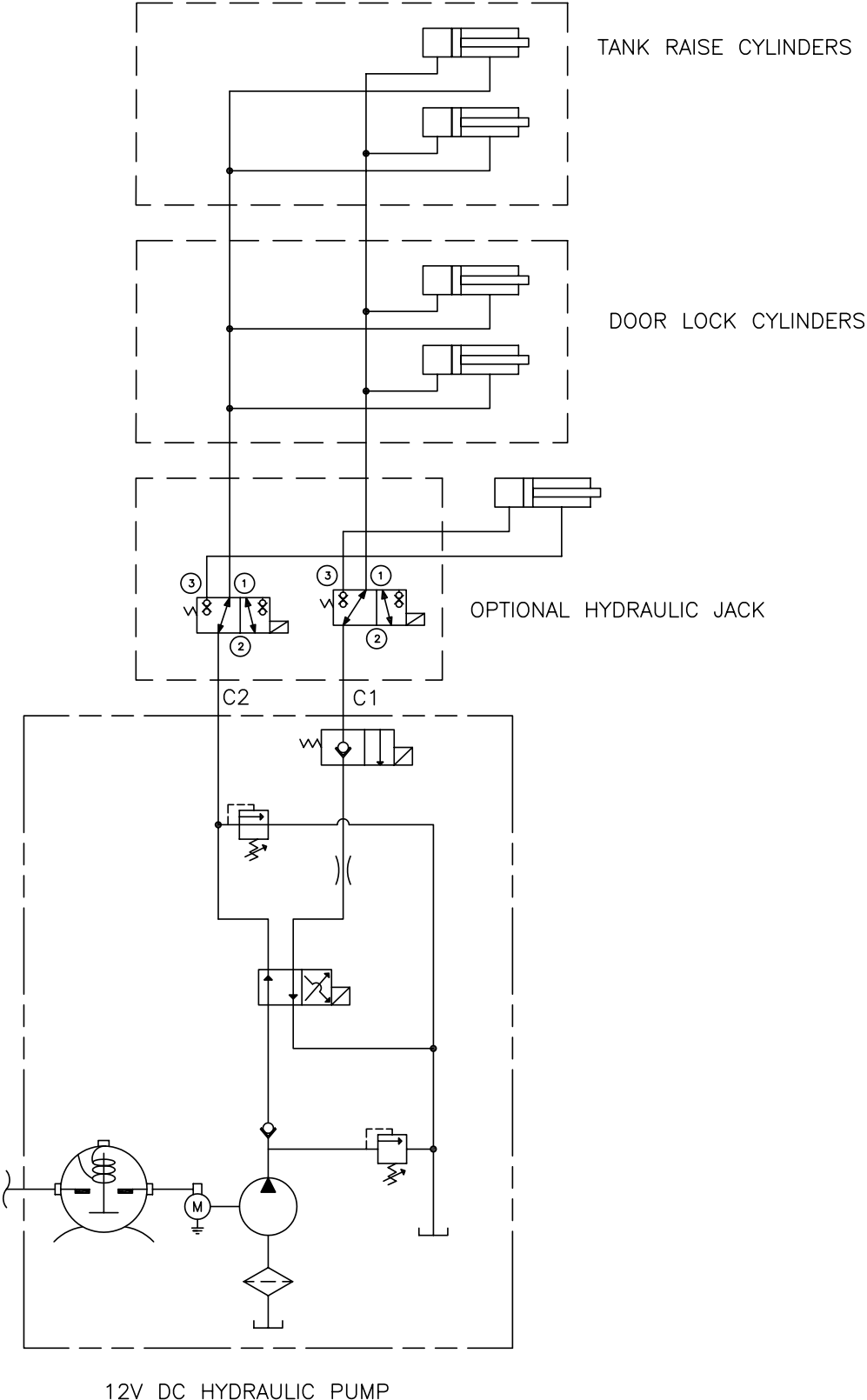

080108

12V DC HYDRAULIC PUMP

PAGE LEFT BLANK

Boom Hydraulic Schematic

BOOM HYDRAULIC SCHEMATIC

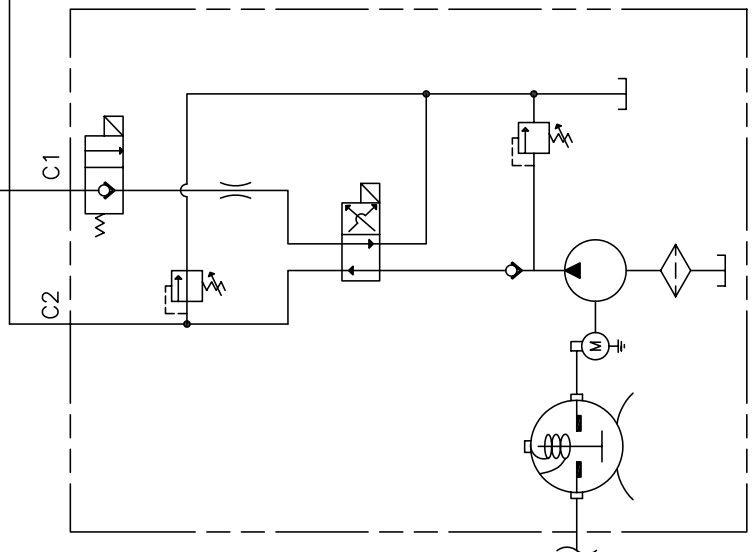
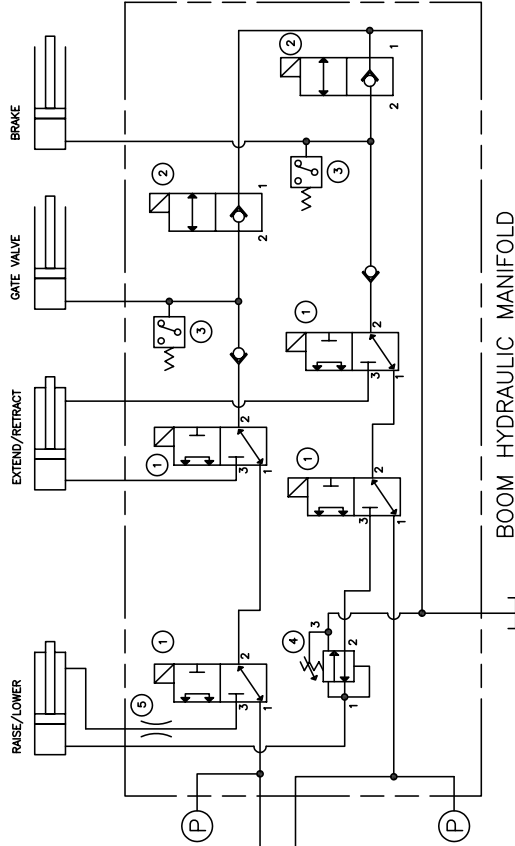

12V DC HYDRAULIC PUMP

MCL#	MFG	TYPE	MODEL
1	VICKERS	3 WAY VALVE	SV1-10
2	VICKERS	2 WAY VALVE	SV3-10-C-6T12DG
*3	NASON	PRESSURE SWITCH	XM-4B-2000R/HR
4	VICKERS	RETRACT VALVE	PRV2-10
5		ORIFICE .031	

*PRESSURE SETTING 1000psi

PAGE LEFT BLANK

ROOTS

Blowers Compressors Exhausters

Universal URAI-DSL

Contents

Information Summary	Troubleshooting
Safety Precautions	Inspection & Maintenance
Operating Limitations	Data
Lubrication	Assembly Drawings
Operation	Parts List

Do These Things To Get The Most From Your ROOTS™ blower

- **Make sure both driving and driven equipment is correctly lubricated before start-up. See LUBRICATION.**
- In event of trouble during installation or operation, do not attempt repairs of ROOTS furnished equipment. Notify ROOTS, giving all nameplate information plus an outline of operating conditions and a description of the trouble. Unauthorized attempts at equipment repair may void ROOTS warranty.
- Units out of warranty may be repaired or adjusted by the owner. Good inspection and maintenance practices should reduce the needs for repairs.

NOTE: Information in this manual is correct as of the date of publication. ROOTS reserves the right to make design or material changes without notice, and without obligation to make similar changes without notice, and without obligation to make similar changes on equipment of prior manufacture.

Safety Precautions

It is important that all personnel observe safety precautions to minimize the chances of injury. Among many considerations, the following should be particularly noted:

- Blower casing and associated piping or accessories may become hot enough to cause major skin burns on contact.
- Internal and external rotating parts of the blower and driving equipment can produce serious physical injuries. Do not reach into any opening in the blower while it is operating, or while subject to accidental starting. Protect external moving parts with adequate guards.
- Disconnect power before doing any work, and avoid bypassing or rendering inoperative any safety or protective devices.
- If blower is operated with piping disconnected, place a strong coarse screen over the inlet and avoid standing in the discharge air stream. **CAUTION: Never cover the blower inlet with your hand or other part of body.**
- Stay clear of the blast from pressure relief valves and the suction area of vacuum relief valves.
- Use proper care and good procedures in handling, lifting, installing, operating and maintaining the equipment.
- Casing pressure must not exceed 25 PSI (1725 mbar) gauge. Do not pressurize vented cavities from an external source, nor restrict the vents without first consulting Roots.
- Do not use air blowers on explosive or hazardous gases.
- Other potential hazards to safety may also be associated with operation of this equipment. All personnel working in or passing through the area should be trained to exercise adequate general safety precautions.

Operating Limitations

A ROOTS blower or exhauster must be operated within certain approved limiting conditions to enable continued satisfactory performance. Warranty is contingent on such operation.

Maximum limits for pressure, temperature and speed are specified in TABLE 1 for various models & sizes of blowers & exhausters. These limits apply to all units of normal construction, when operated under standard atmospheric conditions. Be sure to arrange connections or taps for instruments, thermometers and pressure or vacuum gauges at or near the inlet and discharge connections of the unit. These, along with a tachometer, will enable periodic checks of operating conditions.

PRESSURE – The pressure rise, between inlet and discharge, must not exceed the figure listed for the specific unit frame size concerned. Also, in any system where the unit inlet is at a positive pressure above atmosphere a maximum case rating of 25 PSI gauge (1725 mbar) should not be exceeded without first consulting Roots. Never should the maximum allowable differential pressure be exceeded.

On vacuum service, with the discharge to atmospheric pressure, the inlet suction or vacuum must not be greater than values listed for the specific frame size.

TEMPERATURE – Blower & exhauster frame sizes are approved only for installations where the following temperature limitations can be maintained in service:

- Measured temperature rise must not exceed listed values when the inlet is at ambient temperature. Ambient is considered as the general temperature of the space around the unit. This is not outdoor temperature unless the unit is installed outdoors.
- If inlet temperature is higher than ambient, the listed allowable temperature rise values must be reduced by 2/3 of the difference between the actual measured inlet temperature and the ambient temperature.
- The average of the inlet and discharge temperature must not exceed 250°F. (121°C).
- The ambient temperature of the space the blower/motor is installed in should not be higher than 120°F (48.8°C).

SPEED – These blowers & exhausters may be operated at speeds up to the maximum listed for the various frame sizes. They may be direct coupled to suitable constant speed drivers if pressure/temperature conditions are also within limits. At low speeds, excessive temperature rise may be a limiting factor.

Special Note: The listed maximum allowable temperature rise for any particular blower & exhauster may occur well before its maximum pressure or vacuum rating is reached. This may occur at high altitude, low vacuum or at very low speed. The units' operating limit is always determined by the maximum rating reached first. It can be any one of the three: Pressure, Temperature or Speed.

Lubrication

For Units with Splash Lubrication on Both Ends

Bearings and oil seals are lubricated by the action of the timing gears or oil slingers which dip into the main oil sumps

causing oil to splash directly on gears and into bearings and seals. A drain port is provided below each bearing to prevent an excessive amount of oil in the bearings. Seals located inboard of the bearings in each headplate effectively retain oil within the sumps. Any small leakage that may occur should the seals wear passes into a cavity in each vented headplate and is drained downward.

Oil sumps on each end of the blower are filled by removing top vent plugs, Item (25), and filling until oil reaches the middle of the oil level sight gauge when the unit is not operating, Item (45 or 53), DO NOT FILL PAST THE MIDDLE OF THE SIGHT GLASS.

Initial filling of the sumps should be accomplished with the blower not operating, in order to obtain the correct oil level. Approximate oil quantities required for blowers of the various models and configurations are listed in Table 3. Use a good grade of industrial type non-detergent, rust inhibiting, anti-foaming oil and of correct viscosity per Table 2. ***ROOTS synthetic oil (Roots P/N 813-106-) is specified and recommended.** Roots does not recommend automotive type lubricants, as they are not formulated with the properties mentioned above.

The oil level may rise or fall on the gauge during operation, to an extent depending somewhat on oil temperature and blower speed.

Proper lubrication is usually the most important single consideration in obtaining maximum service life and satisfactory operation from the unit. Unless operating conditions are quite severe, a weekly check of oil level and necessary addition of lubricant should be sufficient. During the first week of operation, check the oil levels in the oil sumps about once a day, and watch for leaks. Replenish as necessary. Thereafter, an occasional check should be sufficient. It is recommended that the oil be changed after initial 100 hours of operation. Frequent oil changing is not necessary unless the blower is operated in a very dusty location.

Normal life expectancy of petroleum based oils is about 2000 hours with an oil temperature of about 180°F (82°C). As the oil temperature increases by increments of 15-18°F (8°C - 10°C), the life is reduced by half. Example: Oil temperatures of 210-216°F (99°C - 102°C) will produce life expectancy of 1/4 or 500 hours. Therefore, it is considered normal to have oil change periods of 500 hours with petroleum based oils.

Normal life expectancy of ROOTS™ Synthetic Oil is about 4000 to 8000 hours with an oil temperature of about 180°F (82°C). As the oil temperature increases by increments of 15-18°F (8°C - 10°C), the life is reduced by half. Example: Oil temperatures of 210-216°F (99°C - 102°C) will produce life expectancy of 1/4 or 1000 to 2000 hours.

NOTE: To estimate oil temperature, multiply the discharge temperature of the blower by 0.80. Example: if the discharge air temperature of the blower is 200° F, it is estimated that the oil temperature is 160° F.

*ROOTS™ Synthetic Oil & Grease is superior in performance to petroleum based products. It has high oxidation stability, excellent corrosion protection, extremely high film strength and low coefficient of friction. Typical oil change intervals are increased 2-3 times over petroleum based lubricants. Also, ROOTS™ Synthetic Oil is 100% compatible with petroleum based oils. Simply drain the oil in the blower and refill the reservoirs with ROOTS™ Synthetic Oil to maintain optimum performance of your ROOTS™ blower.

Operation

Before operating a blower under power for the first time, recheck the unit and the installation thoroughly to reduce the likelihood of avoidable troubles. Use the following procedure check list as a guide, but consider any other special conditions in the installation.

- Be certain that no bolts, tools, rags, or debris have been left in the blower air chamber or piping.
- If an outdoor intake without filter is used, be sure the opening is located so it cannot pick up dirt and is protected by a strong screen or grille. Use of the temporary protective screen as described under INSTALLATION is strongly recommended.
- Recheck blower leveling, drive alignment and tightness of all mounting bolts if installation is not recent. If belt drive is used, adjust belt tension correctly.
- Turn drive shaft by hand to make sure impellers still rotate without bumping or rubbing at any point.
- Ensure oil levels in the main oil sumps are correct.
- Check lubrication of driver. If it is an electric motor, be sure that power is available and that electrical overload devices are installed and workable.
- Open the manual unloading valve in the discharge air line. If a valve is in the inlet piping, be sure it is open.
- Bump blower a few revolutions with driver to check that direction of rotation agrees with arrow near blower shaft, and that both coast freely to a stop.

After the preceding points are cleared, blower is ready for trial operation under "no-load" conditions. The following procedure is suggested to cover this initial operation test period.

- a. Start blower, let it accelerate to full speed, then shut off. Listen for knocking sounds, both with power on and as speed slows down.
- b. After blower comes to a complete stop, repeat above, but let blower run 2 or 3 minutes. Check for noises, such as knocking sounds.
- c. After blower comes to a complete stop, operate blower for about 10 minutes unloaded. Check oil levels. Observe cylinder and headplate surfaces for development of hot spots such as burned paint, indicating impeller rubs. Be aware of any noticeable increase in vibration.

Assuming that all trials have been satisfactory, or that necessary corrections have been made, the blower should now have a final check run of at least one hour under normal operating conditions. After blower is restarted, gradually

close the discharge unloading valve to apply working pressure. At this point it is recommended that a pressure gauge or manometer be connected into the discharge line if not already provided, and that thermometers be in both inlet and discharge lines. Readings from these instruments will show whether pressure or temperature ratings of the blower are being exceeded.

During the final run, check operating conditions frequently and observe the oil levels at reasonable intervals. If excessive noise or local heating develops, shut down immediately and determine the cause. If either pressure rise or temperature rise across the blower exceeds the limit specified in this manual, shut down and investigate conditions in the piping system. Refer to the TROUBLESHOOTING CHECKLIST for suggestions on various problems that may appear.

The blower should now be ready for continuous duty operation at full load. During the first few days make periodic checks to determine whether all conditions remain steady, or at least acceptable. This may be particularly important if the blower is supplying air to a process system where conditions can vary. At the first opportunity, stop the blower and clean the temporary inlet protective screen. If no appreciable amount of debris has collected, the screen may be removed. See comments under INSTALLATION. At this same time, verify leveling, coupling alignment or belt tension, and mounting bolt tightness.

Should operating experience prove that blower capacity is a little too high for the actual air requirements, a small excess may be blown off continuously through the manual unloading or vent valve. Never rely on the pressure relief valve as an automatic vent. Such use may cause the discharge pressure to become excessive, and can also result in failure of the valve itself. If blower capacity appears to be too low, refer to the TROUBLESHOOTING CHECKLIST.

Vibration Assessment Criteria

With measurements taken at the bearing locations on the housings, see chart below for an appropriate assessment guide for rotary lobe blowers rigidly mounted on stiff foundations.

In general, blower vibration levels should be monitored on a regular basis and the vibration trend observed for progressive or sudden change in level. If such a change occurs, the cause should be determined through spectral analysis.

As shown on the chart below, the level of all pass vibration will determine the need to measure discrete frequency vibration levels and the action required.

All Pass Vibration (in/sec)	Discrete Frequency Vibration (in/sec)	Action
0.45 or less	N/R	Acceptable
Greater than 0.45 but 1.0 or less	0.45 or less @ any frequency	Acceptable
	Greater than 0.45 @ any frequency	Investigate
Greater than 1.0	Less than 1.0	Investigate
	Greater than 1.0	Investigate

Troubleshooting Checklist

Trouble	Item	Possible Cause	Remedy
No flow	1	Speed too low	Check by tachometer and compare with published performance
	2	Wrong rotation	Compare actual rotation with Figure 1 Change driver if wrong
	3	Obstruction in piping	Check piping, valves, silencer to assure open flow path
Low capacity	4	Speed too low	See item 1, If belt drive, check for slippage and readjust tension
	5	Excessive pressure rise	Check inlet vacuum and discharge pressure and compare with Published performance
	6	Obstruction in piping	See item 3
	7	Excessive slip	Check inside of casing for worn or eroded surfaces causing excessive clearances
Excessive power	8	Speed too high	Check speed and compare with published performance
	9	Excessive pressure rise	See Item 5
	10	Impeller rubbing	Inspect outside of cylinder for high temperature areas, then check for impeller contact at these points. Correct blower mounting, drive alignment
	11	Scale, sludge, rust or product build up	Clean blower appropriately
Damage to bearings or gears	12	Inadequate lubrication	Check oil sump levels in gear and drive end headplates
	13	Excessive lubrication	Check oil levels. If correct, drain and refill with clean oil of recommended grade
	14	Excessive pressure rise	See Item 5
	15	Coupling misalignment	Check carefully. Realign if questionable
Vibration	16	Excessive belt tension	Readjust for correct tension
	17	Misalignment	See Item 15
	18	Impellers rubbing	See Item 10
	19	Worn bearings/gears	Check gear backlash and condition of bearings, and replace as indicated
	20	Unbalanced or rubbing impeller	Scale or process material may build up on casing and impellers, or inside impellers. Remove build-up to restore original clearances and impeller balance
	21	Driver or blower loose	Tighten mounting bolts securely
	22	Piping resonances	Determine whether standing wave pressure pulsations are present in the piping
	23	Scale/sludge build-ups	Clean out interior of impeller lobes to restore dynamic balance
Driver stops, or will not start	24	Casing strain	Re-work piping alignment to remove excess strain
	25	Impeller stuck	Check for excessive hot spot on headplate or cylinder. See item 10. Look for defective shaft bearing and/or gear teeth
	26	Scale, sludge, rust or product build-up	Clean blower appropriately
Excessive breather	27	Broken seal	Replace seals
Blow-by or excessive oil leakage to vent area	28	Defective O-ring	Replace seals and O-ring
Excessive oil leakage in vent area	29	Defective/plugged breather	Replace breather and monitor oil leakage
	30	Oil level too high	Check sump levels in gear and drive headplates.
	31	Oil type or viscosity incorrect	Check oil to insure it meets recommendations. Drain then fill with clean oil of recommended grade.
	32	Blower running hot	Check blower operating conditions to ensure they are within the operating limitations defined in this manual.

Inspection & Maintenance: Universal RAI® series blowers

A good program of consistent inspection and maintenance is the most reliable method of minimizing repairs to a blower. A simple record of services and dates will help keep this work on a regular schedule. Basic service needs are:

- Lubrication
- Checking for hot spots
- Checking for increases or changes in vibration and noise
- Recording of operating pressures and temperatures

Above all, a blower must be operated within its specified rating limits, to obtain satisfactory service life.

A newly installed blower should be checked often during the first month of full-time operation. Attention thereafter may be less frequent assuming satisfactory performance. Lubrication is normally the most important consideration and weekly checks of lubricant levels in the gearbox and bearing reservoirs should be customary. Complete oil change schedules are discussed under **LUBRICATION**.

Driver lubrication practices should be in accordance with the manufacturer's instructions. If direct connected to the blower through a lubricated type coupling, the coupling should be checked and greased each time blower oil is changed. This will help reduce wear and prevent unnecessary vibration. In a belted drive system, check belt tension periodically and inspect for frayed or cracked belts.

In a new, and properly installed, unit there is no contact between the two impellers, or between the impellers and cylinder or headplates. Wear is confined to the bearings (which support and locate the shafts) the oil seals, and the timing gears. All are lubricated and wear should be minimal if clean oil of the correct grade is always used. Seals are subject to deterioration as well as wear, and may require replacement at varying periods.

Shaft bearings are designed for optimum life under average conditions with proper lubrication and are critical to the service life of the blower. Gradual bearing wear may allow a shaft position to change slightly, until rubbing develops between impeller and casing. This will cause spot heating, which can be detected by observing these surfaces. Sudden bearing failure is usually more serious. Since the shaft and impeller are no longer supported and properly located, extensive general damage to the blower casing and gears is likely to occur.

Oil seals should be considered expendable items, to be replaced whenever drainage from the headplate vent cavity becomes excessive or when the blower is disassembled for

any reason. Some oil seal leakage may occur since an oil film under the lip is required for proper operation. Periodically leaked oil should be wiped off from surfaces. Minor seal leakage should not be considered as indicating seal replacement.

Timing gear wear, when correct lubrication is maintained, should be negligible. Gear teeth are cut to provide the correct amount of backlash, and gears correctly mounted on the shafts will accommodate a normal amount of tooth wear without permitting contact between lobes of the two impellers. However, too high an oil level will cause churning and excessive heating. This is indicated by unusually high temperature at the bottom of the gear housing. Consequent heating of the gears will result in loss of tooth-clearance, backlash and rapid wear of the gear teeth usually will develop. Continuation of this tooth wear will eventually produce impeller contacts (knocking), and from this point serious damage will be unavoidable if blower operation is continued. A similar situation can be produced suddenly by gear tooth fracture, which is usually brought on by sustained overloading or momentary shock loads.

Problems may also develop from causes other than internal parts failure. Operating clearances within a blower are only a few thousandths of an inch. This makes it possible for impeller interference or casing rubs to result from shifts in the blower mounting, or from changes in piping support. If this type of trouble is experienced, and the blower is found to be clean, try removing mounting strains. Loosen blower mounting bolts and reset the leveling and drive alignment. Then tighten mounting again, and make sure that all piping meets blower connections accurately and squarely. Foreign materials in the blower will also cause trouble, which can only be cured by disconnecting the piping and thoroughly cleaning the blower interior.

A wide range of causes & solutions for operating troubles are covered in the **TROUBLE SHOOTING CHECKLIST**. The remedies suggested should be performed by qualified mechanics with a good background. Major repairs generally are to be considered beyond the scope of maintenance, and should be referred to an authorized Roots distributor.

Warranty failures should not be repaired at all, unless specific approval has been obtained through Roots before starting work. Unauthorized disassembly within the warranty period may void the warranty.

Figure 2 - Allowable Overhung Loads for V-Belt Drives Universal RAI®/URAI®-DSL Units

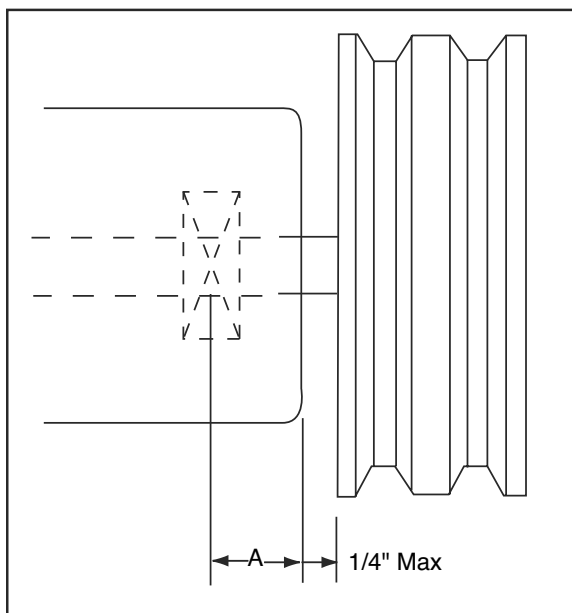

$$\text{Belt Pull lbs} = \frac{252100 \cdot \text{Motor HP}}{\text{Blower RPM} \cdot \text{Sheave Diameter}}$$

$$\text{Shaft Load (lb.in)} = \text{Belt Pull} \cdot \left(A + \frac{1}{4} + \frac{\text{Sheave Width}}{2} \right)$$

Frame Size	Dimension "A"	Max Allowable Shaft Load (lb-in)	Min Sheave Diameter
59	1.13	1,325	6.00

NOTE:

Arc of sheave belt contact on the smaller sheave not to be less than 170°

Driver to be installed on the inlet side for vertical units, and on the drive shaft side for horizontal units.

Roots recommends the use of two or more 3V, 5V or 8V matched set or banded belts and sheaves.

Specified Lubricants

ROOTS Synthetic Oil: ISO-VG-320 Grade

	Part Number
Quart	13106004
Gallon	13106005
Case (12 qts)	13106007

ROOTS Synthetic Oil: ISO-VG-220 Grade

	Part Number
Quart	13106001
Gallon	13106002
Case (12 qts)	13106008

ROOTS Synthetic Oil: ISO-VG-150 Grade

	Part Number
Quart	13106020
Gallon	13106021
Case (12 qts)	13106023
5 Gallon Pail	13106022
55 Gallon Drum	13106025

Drive End Breather Orientation for URA-DSL blowers with Oil Lube

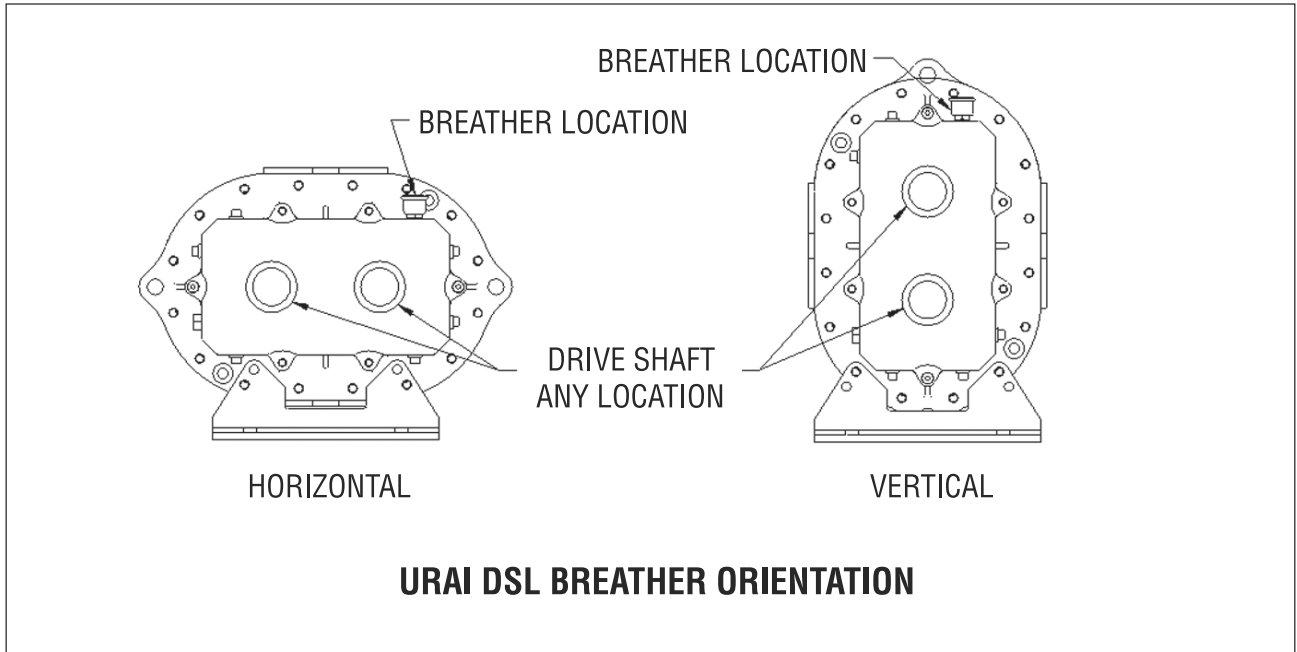

Table 1 - URAI, URAI-DSL Blowers,
Maximum Allowable Operating Conditions

Frame Size	Gear Diameter (Inch)	Speed RPM	Temp. Rise Deg F (Deg C)	Delta Pressure PSI (mbar)	Inlet Vacuum INHG (mbar)
59	5	2,850	225 (125)	7 (483)	15 (500)

Table 2 - Recommended Oil Grades

Ambient Temperature °F (°C)	ISO Viscosity No.
Above 90° (32°)	320
32° to 90° (0° to 32°)	220
0° to 32° (-18° to 0°)	150
Below 0° (-18°)	100

Ambient temperature is defined as the temperature of the space in which the blower and drive are located.

Table 3 - Approximate Oil Sump Capacities

These capacities are provided to assist in stocking the correct amount of oil. Exact sump capacities may differ slightly. See “Lubrication” section for proper filling instructions.

URAI-DSL Splash Lubricated Blowers

Frame Size	Gear End Capacity Fl. Oz (Liters)	Drive End Capacity Fl. Oz. (Liters)
59	27.6 (.82)	14.8 (.44)

Basic Connection & Drive Shaft Information

URAI DSL AIR BLOWERS (with Dual Splash Lubrication DSL)

BOM#	FRAME SIZE	INLET/DISCHARGE CONN.	SHAFT DIAMETER	BARE WEIGHT
T30361020	59	4" NPT	1.125	209

Universal RAI air blowers include detachable mounting feet which permit vertical or horizontal installation. The units are center timed for rotation in either direction. The bearings on the URAI are grease lubricated on the drive end and splash lubricated on the gear end. The URAI-DSL is splash lubricated on BOTH ends.

PAGE LEFT BLANK

WIRING DIAGRAMS

KTC/SAE standard (Energize to run)

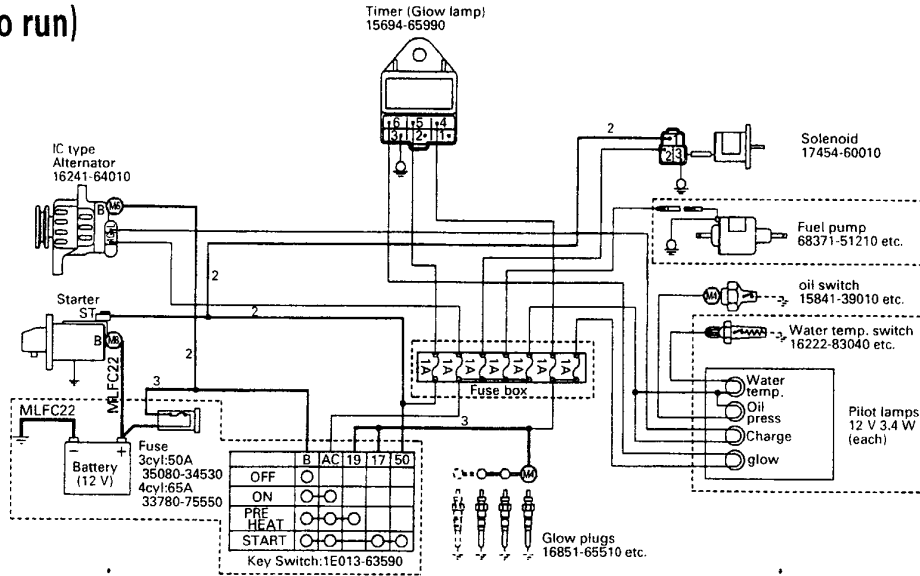

- ★ The parts boxed in [] are reference, NOT equipped for standard engine spec.
- ★ Non marked wire dia. is 0.8~1.25 mm².

PAGE LEFT BLANK

WARRANTY RETURN GOODS POLICY

LIMITED WARRANTY

The Manufacturer warrants its products to be free from defects in material and workmanship for a period of twelve months from the date of shipment from the factory. The Manufacturer shall not be responsible for any damage resulting to or caused by its products by reason of installation, improper storage, unauthorized service, alteration of the products, neglect or abuse, or use of the product in a manner inconsistent with its design. The warranty does not extend to any component parts not manufactured by Manufacturer; however, Manufacturer's warranty herein shall not limit any warranties made by manufacturers of component parts which extend to Buyer.

Claims for defects in material and workmanship shall be made in writing to Manufacturer within ten days of discovery of defect. Manufacturer may either send a service representative or have the product returned to its factory at Buyer's expense for inspection. Upon notification of defect, Manufacturer will issue a return goods authorization number to Buyer. The return goods authorization number must accompany the product returned. If judged by the Manufacturer to be defective in material or workmanship, the product will be replaced or repaired at the option of the Manufacturer, free from all charges except authorized transportation. Buyer shall be responsible for all maintenance services consisting of lubrication and cleaning of equipment, replacing expandable parts, making minor adjustments, and performing operating checks, all in accordance with procedures outlined in Manufacturer's maintenance literature.

THE FOREGOING WARRANTY IS IN LIEU OF ALL OTHER WARRANTIES AND NO REPRESENTATIONS, GUARANTEES, OR WARRANTIES, EXPRESS OR IMPLIED, (INCLUDING BUT NOT LIMITED TO A WARRANTY OF MERCHANTABILITY OR FITNESS FOR A PARTICULAR PURPOSE), ARE MADE BY THE MANUFACTURER IN CONNECTION WITH THE MANUFACTURE OR SALE OF ITS PRODUCTS. NO EMPLOYEE, DISTRIBUTOR, OR REPRESENTATIVE IS AUTHORIZED TO CHANGE THIS WARRANTY ON BEHALF OF MANUFACTURER. THE REMEDIES OF BUYER SET FORTH HEREIN ARE EXCLUSIVE AND ARE IN LIEU OF ALL OTHER REMEDIES. THE LIABILITY OF MANUFACTURER WHETHER IN CONTRACT, TORT, UNDER ANY WARRANTY, OR OTHERWISE SHALL NOT EXTEND BEYOND ITS OBLIGATION TO REPAIR OR REPLACE, AT ITS OPTION ANY PRODUCT OR PART FOUND BY MANUFACTURER TO BE DEFECTIVE IN MATERIAL OR WORKMANSHIP. MANUFACTURER SHALL NOT BE LIABLE FOR COST OF INSTALLATION AND/OR REMOVAL OR BE RESPONSIBLE FOR DIRECT, INDIRECT, SPECIAL OR CONSEQUENTIAL DAMAGES OF ANY NATURE.

GENERAL RETURNS OF MERCHANDISE

1. All returns must be pre-authorized
 - A. Please call our parts department for an RGA number
 - B. Please include RGA number on the outside of box
 - C. Include any required paper work or special instructions
 - D. Items returned without an RGA number will not be accepted
2. All returns are subject to a 20% restock charge.
3. Special items are non-returnable
 - A. Non-stock parts
 - B. Custom parts
 - C. If you are unsure about a parts status when ordering, ask your McLaughlin representative if the item fits on of the above conditions.
4. Items must be returned within thirty days of original order date.
5. Items not returned within 30 days from the date of RGA is issued will not be accepted.
6. The item(s) must be in new condition. Used item(s) are not returnable.

Notes

Lined writing area with horizontal lines for notes.