



**McLAUGHLIN<sup>®</sup>**

Toll Free: 800/435-9340 - Phone: 864/277-5870

Fax: 864/235-9661 - Website address: [www.mclaughlinunderground.com](http://www.mclaughlinunderground.com)

Email address: [mmole@mightymole.com](mailto:mmole@mightymole.com)

**Parts Manual**  
**Vermeer/ McLaughlin V500/V800/V1200**  
**Vacuum Machine**  
**Part # E850806**  
**(SERIAL # 8D082609373- 083011575)**

© 2008 by McLaughlin Group, Inc.

020108

All rights reserved. No part of this manual may be reproduced in any form, or by any means without prior written permission of McLaughlin Group, Inc.

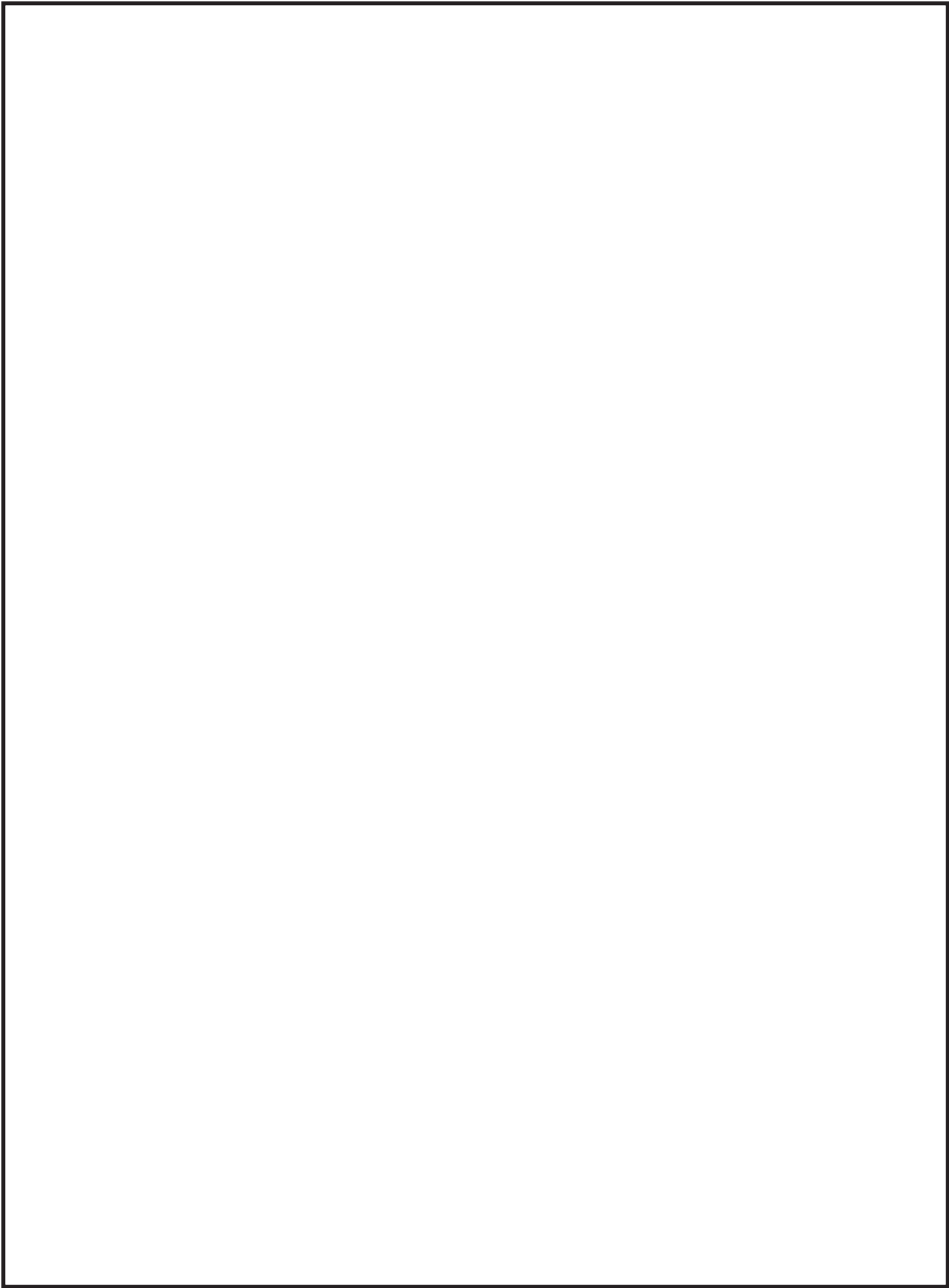

# Table of Contents

## PARTS

### SPOIL TANK AND FILTRATION

HYDRAULIC DOOR .....	4
FILTRATION .....	8

### ENGINE COMPARTMENT

ENCLOSURE .....	12
ENGINE .....	14
BLOWER .....	16
WATER PUMP .....	22
REGULATOR .....	26
ELECTRICAL .....	30
HYDRAULIC PUMP .....	32

### WATER TANK AND ACCESSORIES

WATER TANKS - 50 GALLON SADDLE.....	34
WATER TANKS - 205 GALLON SADDLE.....	36
HOSE REEL .....	38
ANTIFREEZE .....	40

### TRAILER AND SKID ASSEMBLY

TRAILER .....	42
SKID ASSEMBLY .....	44
HOSES .....	46
HYDRAULIC JACK OPTION .....	48

### TOOLS

TOOL RACK .....	50
REDUCTION TOOL .....	52
WASH WAND .....	54
SUCTION TOOL .....	56
LAWN SWEEPER .....	58
VALVE BOX CLEAN OUT TOOL .....	60
SURFACE CLEANER .....	62
ROTARY LANCE .....	64

### OPTIONS

HOT BOX .....	66
ARROW BOARD .....	68

## ELECTRICAL SCHEMATICS

VACUUM DIESEL ENGINE .....	70
HOT BOX .....	78
ARROW BOARD .....	80

## HYDRAULIC SCHEMATICS

TANK AND OPTIONAL JACK .....	82
------------------------------	----

## MAINTENANCE MANUALS

ROOTS BLOWER .....	84
KUBOTA ENGINE .....	96

WARRANTY .....	130
----------------	-----

# Hydraulic Door Option

## V500

### INLET FITTINGS

STD

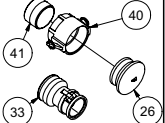

HD

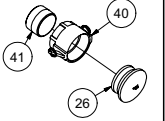

HD REV FLOW

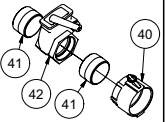

STD REV FLOW

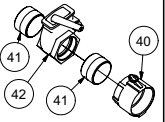

### OUTLET FITTINGS

STD



HD



HD REV FLOW

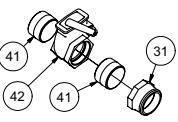

STD REV FLOW

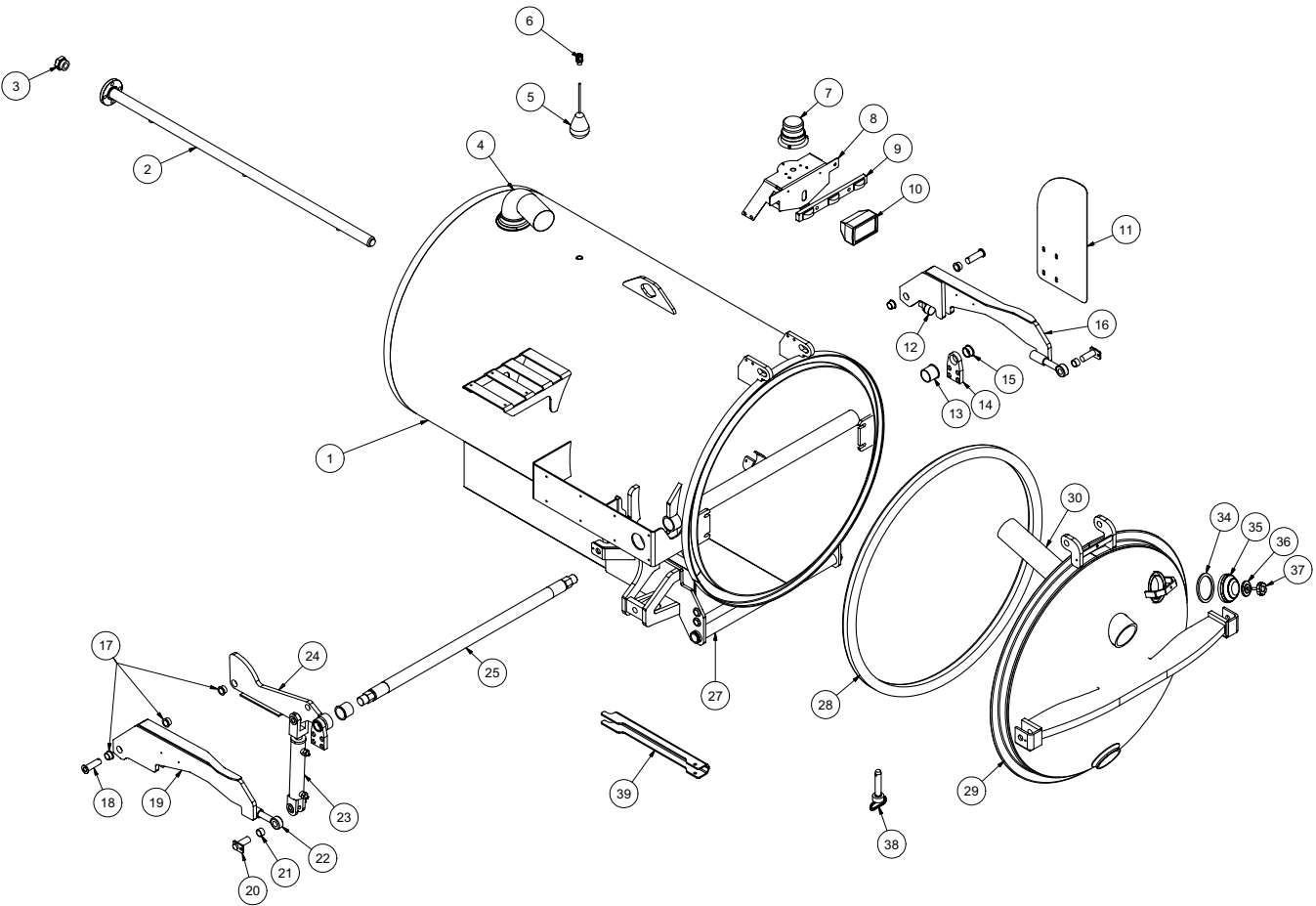
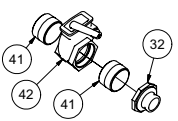

100410-E

VACASSY016

# Hydraulic Door Option

# V500

ITEM	QTY	NUMBER	DESCRIPTION	ITEM	QTY	NUMBER	DESCRIPTION
1	1	8041292	TANK	20	2	8042171	DOORARM PIN
2	1	8043166	TANK ROD		2	U000400	SCREW, HC 3/8-16 X 0.75
	1	8030446	O-RING #328 BUNA		2	U210060	WASHER, LOCK 3/8"
	4	U000880	SCREW, HC 1/2"-13 X 2"	21	2	8041524	BUSHING 1"
	4	U100120	NUT, HEX 1/2"-13	22	2	8043131	1" ROD END
	8	U200100	WASHER, FLAT 1/2"		12	U200171	WASHER, FLAT 1" SAE
	3	U010055	SCREW, HSH 5/16-18 X 1 1/2"	23	2	8041327	DOOR LOCK CYLINDERS
	3	8030369	TANK CLEANOUT NOZZLES		4	T400611	REDUCER 1/2"MSAE - 1/4"MJIC
3	1	T400261	REDUCER 1"MSAE - 3/8"MJIC		2	8042928	DOOR CYL BASE END HOSE 4-38 ST-ST
4	1	8040786	EXHAUST ELBOW		2	8043304	DOOR CYL ROD END HOSE 4-47 ST-ST
5	1	8030531	HIGH LEVEL FLOAT SWITCH		2	8040970	DOOR CYL SUPPLY/RET HOSE 4-70 ST-ST
	1	8041291	RUBBER BUSHING		2	T400022	REDUCER 6FJ - 4 MJ
	1	8041471	FLOAT TUBE V500LT/V500LTHD		2	T402035	TEE 4MJ - 4MJ 4MJ
6	1	X000113	1/2" STRAIN RELIEF	24	2	8041604	SHORT LINKAGE
7	1	8043139	STROBE LIGHT	25	1	8041607	LINKAGE CROSS TUBE
8	1	8046507	STROBE LIGHT BRACKET	26	-	8032006	4" PLUG
	1	X200003	WIRE HARNESS, VAC TANK	27	1	8042648	TANK PIVOT ROD
	1	X200100	WIRE HARNESS, VAC TANK SO		2	8030363	2" SPIRAL SNAP RING
	4	U000880	SCREW, HC 1/2"-13 X 2"	28	1	8041765	DOOR SEAL
	4	U210100	WASHER, 1/2" LOCK	29	1	8042064	DOOR
	4	U200100	WASHER, 1/2" FLAT		1	8040058	DOOR HINGE ROD
	2	U010006	SCREW, PHILLIPS #10-24 X 1"		6	U200171	WASHER, FLAT 1" SAE
	4	U200000	WASHER, FLAT #10		2	U500020	1" SNAP RING
	2	U210005	WASHER, LOCK #10	30	1	8041661	INLET TUBE
	2	U100010	NUT, HEX #10-24	31	-	8030844	4" MALE COUPLER
9	1	8041509	TANK CLEARANCE LIGHT	32	-	8045611	4"FNPT X 3" MCAM COUPLER
	2	U010006	SCREW, PHILLIPS #10-24 X 1"	33	-	8041080	4" MCAM X 3" MCAM COUPLER
	4	U200000	WASHER, FLAT #10	34	1	8032007	SIGHT GLASS GASKET
	2	U210005	WASHER, LOCK #10	35	1	8031048	SIGHT GLASS
	2	U100010	NUT, HEX #10-24	36	1	8031047	SIGHT GLASS PLATE
10	1	8043138	WORK LIGHT DEUTSCH	37	1	8031046	SIGHT GLASS HAND WHEEL
11	1	8041635	HYD ARM GUARD	38	1	8041626	DOOR SAFETY PIN
	4	U000400	SCREW, HC 3/8-16 X 0.75		1	8041485	LANYARD CABLE
	4	U200060	WASHER, FLAT 3/8"	39	1	8041212	SAFETY BRACE
	4	U210060	WASHER, LOCK 3/8"		1	8041213	CLIP, SAFETY
12	2	W000020	CAM ROLLER 1 1/4"	40	-	8030846	4" FEMALE COUPLER
	2	U160019	1/2"-20 NY-LOCK NUT		-	8032007	4" COUPLER GASKET
13	2	8041602	2" FLANGED BUSHING	41	-	8030431	4" CLOSE NIPPLE
14	2	8041621	OUTER BEARING PLATE	42	-	8030916	GATE VALVE
	8	8042008	1-1/2" SHIMS		-	8031116	GATE VALVE HANDLE
	8	U000840	SCREW, HC 1/2"-13 X 1 1/2"				
	8	U210100	WASHER, 1/2" LOCK				
	8	U200100	WASHER, 1/2" FLAT				
15	2	8041724	1-1/2" FLANGED BUSHING				
16	1	8041369	LONG LINKAGE CURBSIDE				
	1	8041770	PLASTIC WEAR PLATE				
	2	U010800	SCREW, SFH 1/4"-20 X 3/4"				
17	6	8041883	1" BUSHING FLANGED				
18	6	8042489	HYD DOOR PIN				
	6	U340050	3/16" LYNCH PIN				
19	1	8041375	LONG LINKAGE STREETSIDE				
	1	8041770	PLASTIC WEAR PLATE				
	2	U010800	SCREW, SFH 1/4"-20 X 3/4"				

# Tank and Door Assembly

# V800

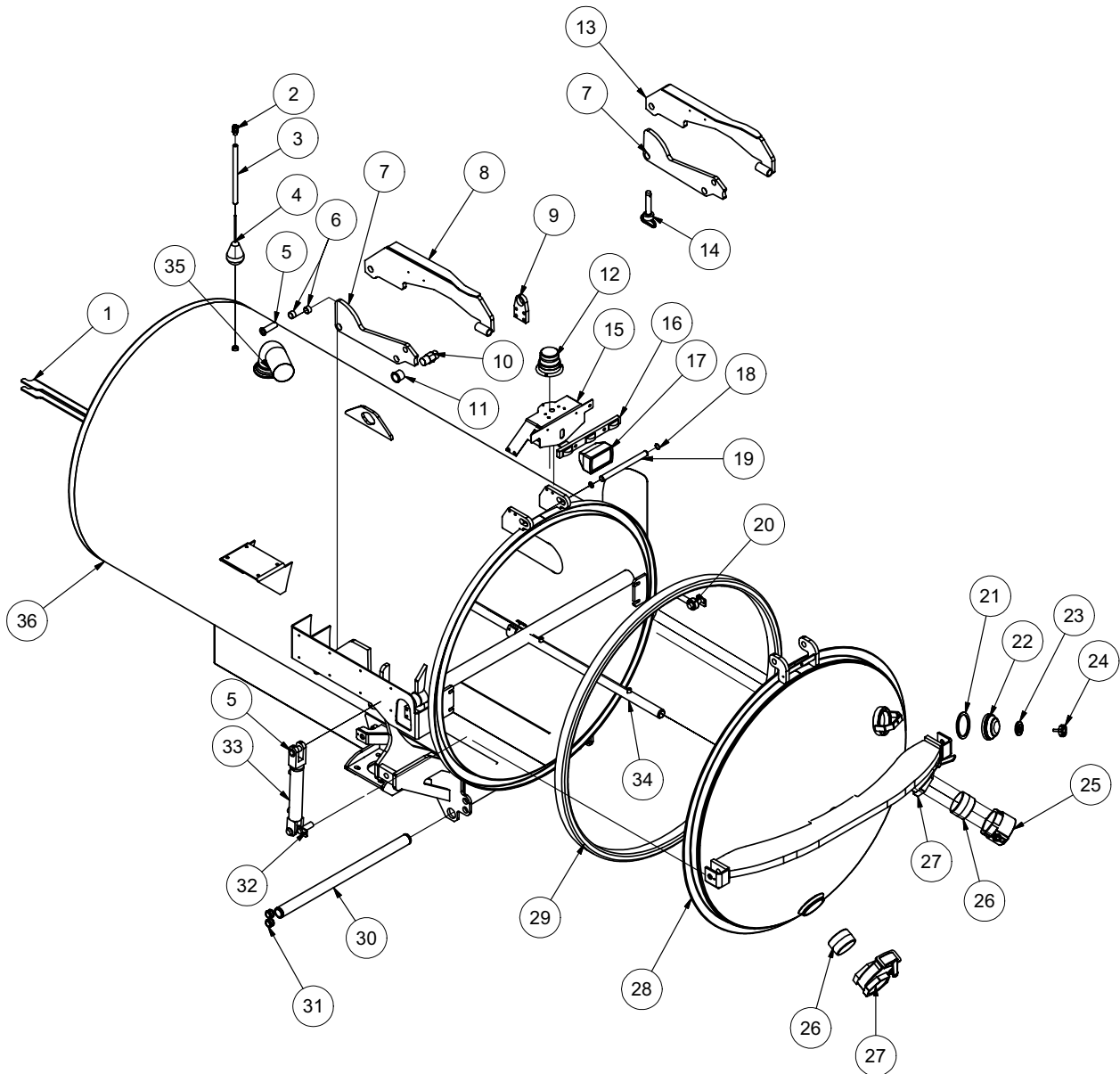

# Tank and Door Assembly

# V800

ITEM#	QTY	NUMBER	DESCRIPTION
1	1	8041212	TANK SAFETY BRACE
2	1	X000113	STRAIN RELIEF, 1/2"
3	1	8041471	HIGH LEVEL FLOAT SWITCH TUBE V800
4	1	8030531	HIGH LEVEL FLOAT SWITCH
5	6	8042489	HYD. DOOR - PIN WELDMENT 1"DIA X 3"
6	6	8041524	BUSHING BRONZE 1.25" X 1.00" X .75"LG
7	2	8041604	SHORT LINKAGE WELDMENT
8	1	8041375	DOOR HYD. LONG LINKAGE SS WELDMENT
9	2	8041621	OUTER BEARING PLATE
10	1	8041663	LINKAGE CROSS TUBE WELDMENT
11	2	8041610	BUSHING BRONZE FLANGED 1 1/2"
12	1	8030347	STROBE LIGHT
13	1	8041369	DOOR HYD. LONG LINKAGE WELDMENT
14	1	8041626	HITCH PIN, 1" X 4 1/2"
15	1	8046507	STROBE LIGHT BRACKET
16	1	8041509	LIGHT CLEARANCE 3 BAR
17	1	8031242	WORKLIGHT
18	2	8030362	1" SNAP RING
19	1	8040058	DOOR HINGE ROD
20	2	8041630	ROD END WITH BRONZE BUSHING
21	1	8032007	GASKET, 4" COUPLER
22	1	8031048	SIGHT GLASS
23	1	8031047	SIGHT GLASS PLATE
24	1	8031046	SIGHT GLASS HAND WHEEL
25	1	8030846	4" FEMALE COUPLER
26	2	8030431	4" CLOSE NIPPLE
27	2	8030916	4" GATE VALVE
28	1	8041580	800/1200 HYD LOCK DOOR
29	1	8041767	DOOR SEAL 54"DIA TANK
30	1	8042648	TANK PIVOT ROD
31	4	8041686	GROMMET 1"ID - 1 1/4"DOG - 1/4"WO
32	2	8042171	DOOR CAPTURE PIN
33	2	8041327	HYD. CYLINDER - 8" STROKE
34	1	8041721	TANK ROD WELDMENT - 800 HYD LOCK DOOR
	3	8030369	NOZZLE, TANK CLEANOUT
35	1	8040786	EXHAUST ELBOW 4" - WELDMENT
36	1	8041643	800 TANK - WELDMENT (54")

# Tank and Door Assembly

# V1200

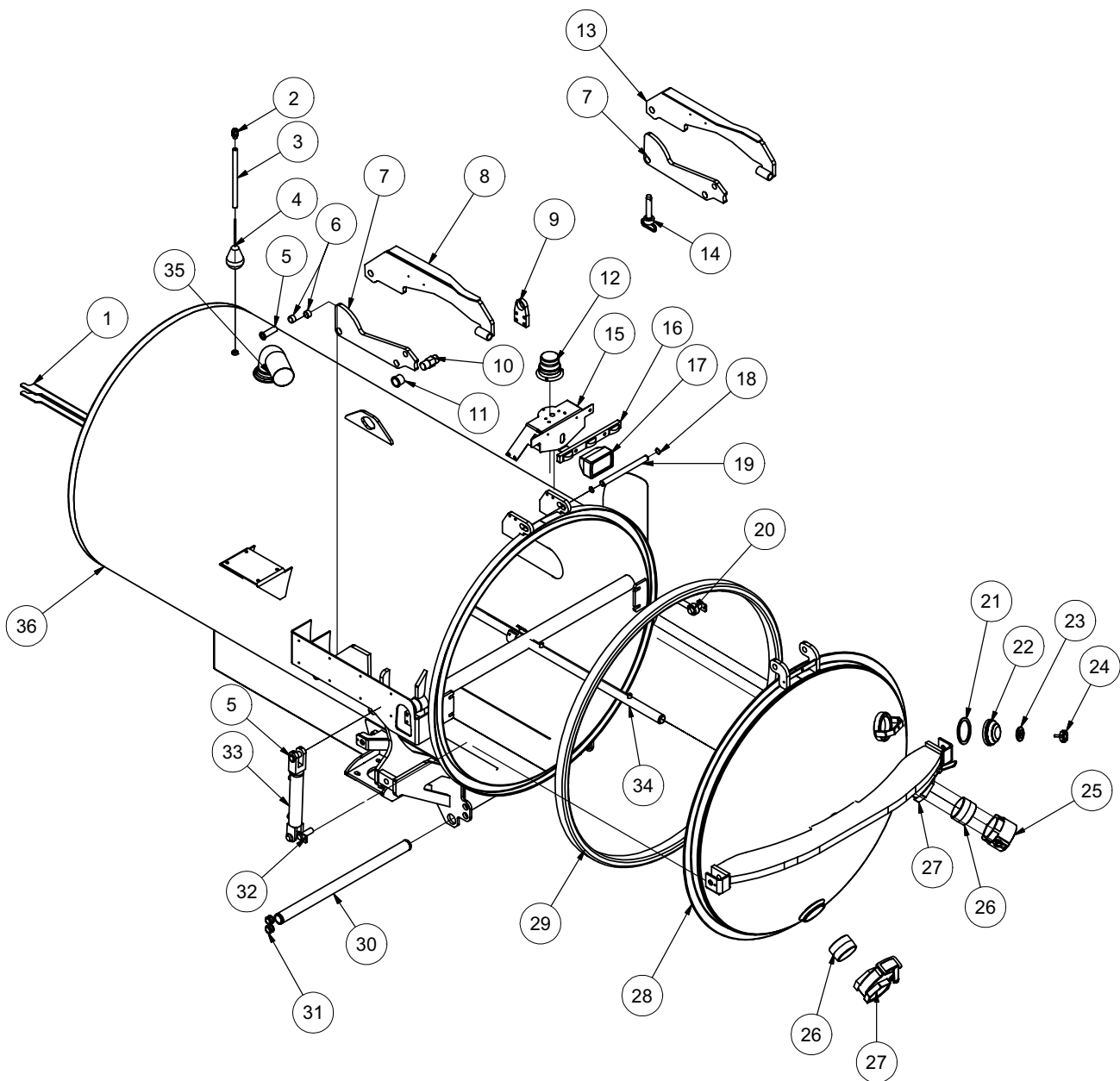



# Tank and Door Assembly

# V1200

ITEM#	QTY	NUMBER	DESCRIPTION
1	1	8041212	TANK SAFETY BRACE
2	1	X000113	STRAIN RELIEF, 1/2"
3	1	8041471	HIGH LEVEL FLOAT SWITCH TUBE V800
4	1	8030531	HIGH LEVEL FLOAT SWITCH
5	6	8042489	HYD. DOOR - PIN WELDMENT 1"DIA X 3"
6	6	8041524	BUSHING BRONZE 1.25" X 1.00" X .75"LG
7	2	8041604	SHORT LINKAGE WELDMENT
8	1	8041375	DOOR HYD. LONG LINKAGE SS WELDMENT
9	2	8041621	OUTER BEARING PLATE
10	1	8041663	LINKAGE CROSS TUBE WELDMENT
11	2	8041610	BUSHING BRONZE FLANGED 1 1/2"
12	1	8030347	STROBE LIGHT
13	1	8041369	DOOR HYD. LONG LINKAGE WELDMENT
14	1	8041626	HITCH PIN, 1" X 4 1/2"
15	1	8046507	STROBE LIGHT BRACKET
16	1	8041509	LIGHT CLEARANCE 3 BAR
17	1	8031242	WORKLIGHT
18	2	8030362	1" SNAP RING
19	1	8040058	DOOR HINGE ROD
20	2	8041630	ROD END WITH BRONZE BUSHING
21	1	8032007	GASKET, 4" COUPLER
22	1	8031048	SIGHT GLASS
23	1	8031047	SIGHT GLASS PLATE
24	1	8031046	SIGHT GLASS HAND WHEEL
25	1	8030846	4" FEMALE COUPLER
26	2	8030431	4" CLOSE NIPPLE
27	2	8030916	4" GATE VALVE
28	1	8041580	800/1200 HYD LOCK DOOR
29	1	8041767	DOOR SEAL 54"DIA TANK
30	1	8042648	TANK PIVOT ROD
31	4	8041686	GROMMET 1"ID - 1 1/4"DOG - 1/4"WO
32	2	8042171	DOOR CAPTURE PIN
33	2	8041327	HYD. CYLINDER - 8" STROKE
34	1	8041721	TANK ROD WELDMENT - 800 HYD LOCK DOOR
	3	8030369	NOZZLE, TANK CLEANOUT
35	1	8040786	EXHAUST ELBOW 4" - WELDMENT
36	1	8043631	1200 TANK - WELDMENT (54")

# Filtration

575

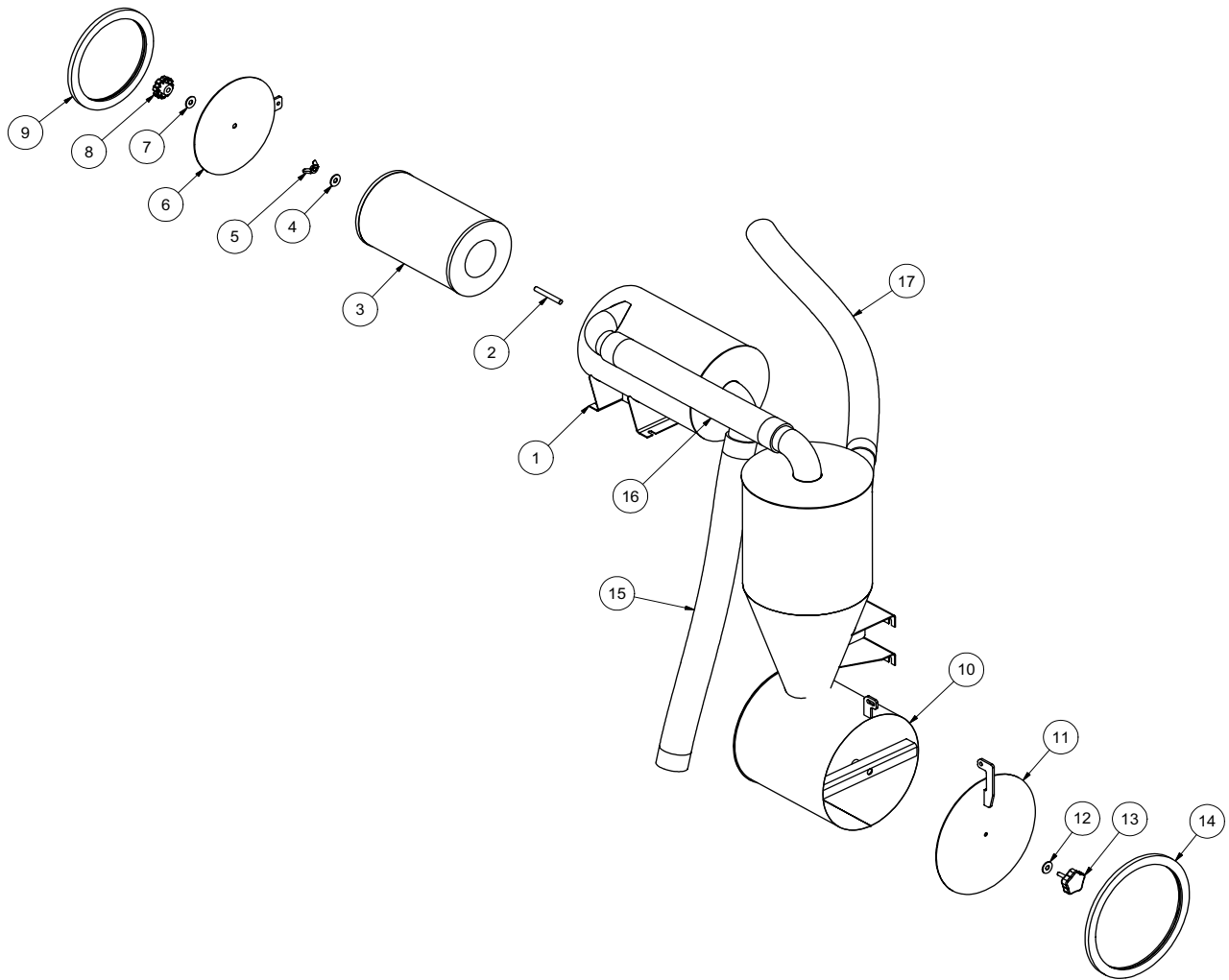

# Filtration

# 575

ITEM	QTY	PART #	DESCRIPTION
1	1	8042441	AIR FILTER HOUSING
	4	U000420	SCREW,HC 3/8-16 X 1.00
	8	U200600	WASHER,FLAT 3/8"
	4	U210061	NUT,HEX NY 3/8-16
2	1	8040302	THREADED ROD - 4" LG
3	1	8031178	FILTER, ELEMENT
4	1	U200100	WASHER, FLAT 1/2"
5	1	8041219	NUT, WIDE WING 1/2 - 13"
6	1	8041534	AIR FILTER HOUSING DOOR
	1	U000560	SCREW, HC 3/8-16 X 3.00
	2	U200600	WASHER,FLAT 3/8"
	1	U210061	NUT,HEX NY 3/8-16
7	1	8041232	WASHER, RUBBER BACKED 1/2"
8	1	8041218	KNOB, AIR FILTER
9	1	8041357	AIR FILTER HOUSING DOOR SEAL
10	1	8042440	CYCLONE SEPERATOR HOUSING
	4	U000420	SCREW,HC 3/8-16 X 1.00
	4	U200600	WASHER,FLAT 3/8"
	4	U210060	WASHER, LOCK
11	1	8041272	575/1025 CYCLONE DOOR
	1	U000460	SCREW, HC 3/8-16 X 1.50
	2	U200600	WASHER,FLAT 3/8"
	1	U210061	NUT,HEX NY 3/8-16
12	1	8041232	WASHER, RUBBER BACKED 1/2"
13	1	8041197	KNOB, CYCLONE
	1	U200600	WASHER,FLAT 3/8"
	1	U210061	NUT,HEX NY 3/8-16
14	1	8041444	CYCLONE DOOR SEAL
15	1	8045658	V500 AIR FILTER TO BLOWER HOSE KANAFLEX 3-97"
	2	8042605	CLAMP HOSE T-BOLT 350
16	1	8045657	CYCLONE TO AIR FILTER HOSE KANAFLEX 3-19 13/16"
	2	8042605	CLAMP HOSE T-BOLT 350
	2	8042605	CLAMP HOSE T-BOLT 350
17	1	8045656	V500 TANK TO CYCLONE HOSE KANAFLEX 3-35 3/8"
	2	8042605	CLAMP HOSE T-BOLT 350

# Filtration

# 575RF

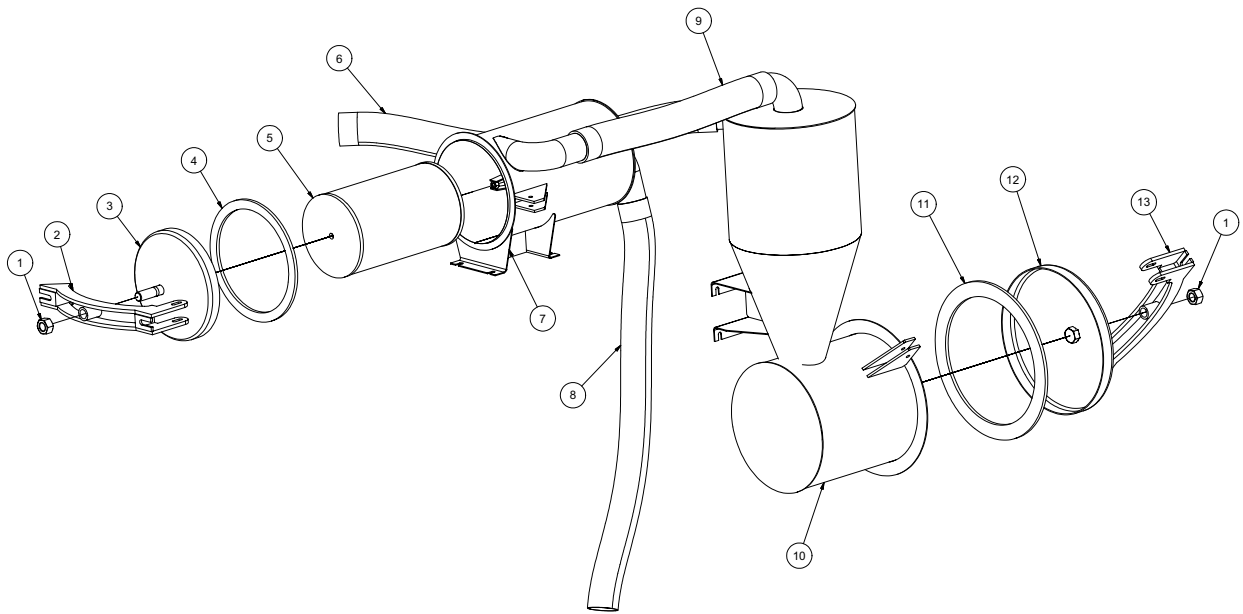

063009

VACASSY352

# Filtration

# 575RF

ITEM	QTY	PART #	DESCRIPTION
1	2	U120060	NUT, LOCK NY 1"- 8
2	1	8044622	DOOR LATCH (AIR FILTER) - WELDMENT
3	1	8044620	575 RF AIR FILTER DOME
4	1	8044819	AIR FILTER GASKET 575RF
5	1	8031178	FILTER, ELEMENT 575
6	1	8043940	TANK TO CYCLONE HOSE KANAFLEX 3-48
	2	8042605	CLAMP HOSE T-BOLT (350)
7	1	8044596	AIR FILTER HSG 575RF
	4	U000420	SCREW, HC 3/8-16 X 3.00
	8	U200600	WASHER, FLAT 3/8"
	4	U210061	NUT, HEX NY 3/8-16
8	1	8043938	AIR FILTER TO BLOWER HOSE KANAFLEX 3-126
	2	8042605	CLAMP HOSE T-BOLT (350)
9	1	8043939	AIR FILTER TO CYCLONE HOSE KANAFLEX 3-20
	2	8042605	CLAMP HOSE T-BOLT (350)
10	1	8044589	CYCLONE 575 REV FLOW
	4	U000420	SCREW, HC 3/8-16 X 1.00
	4	U200600	WASHER, FLAT 3/8"
	4	U210060	WASHER, LOCK 3/8"
11	1	8041612	GASKET, REV FLOW CYCLONE
12	1	8041402	HD CYCLONE DOME DOOR ASSY
13	1	8041552	DOOR LATCH (CYCLONE) - WELDMENT

# Enclosure Assembly

# 36 HP

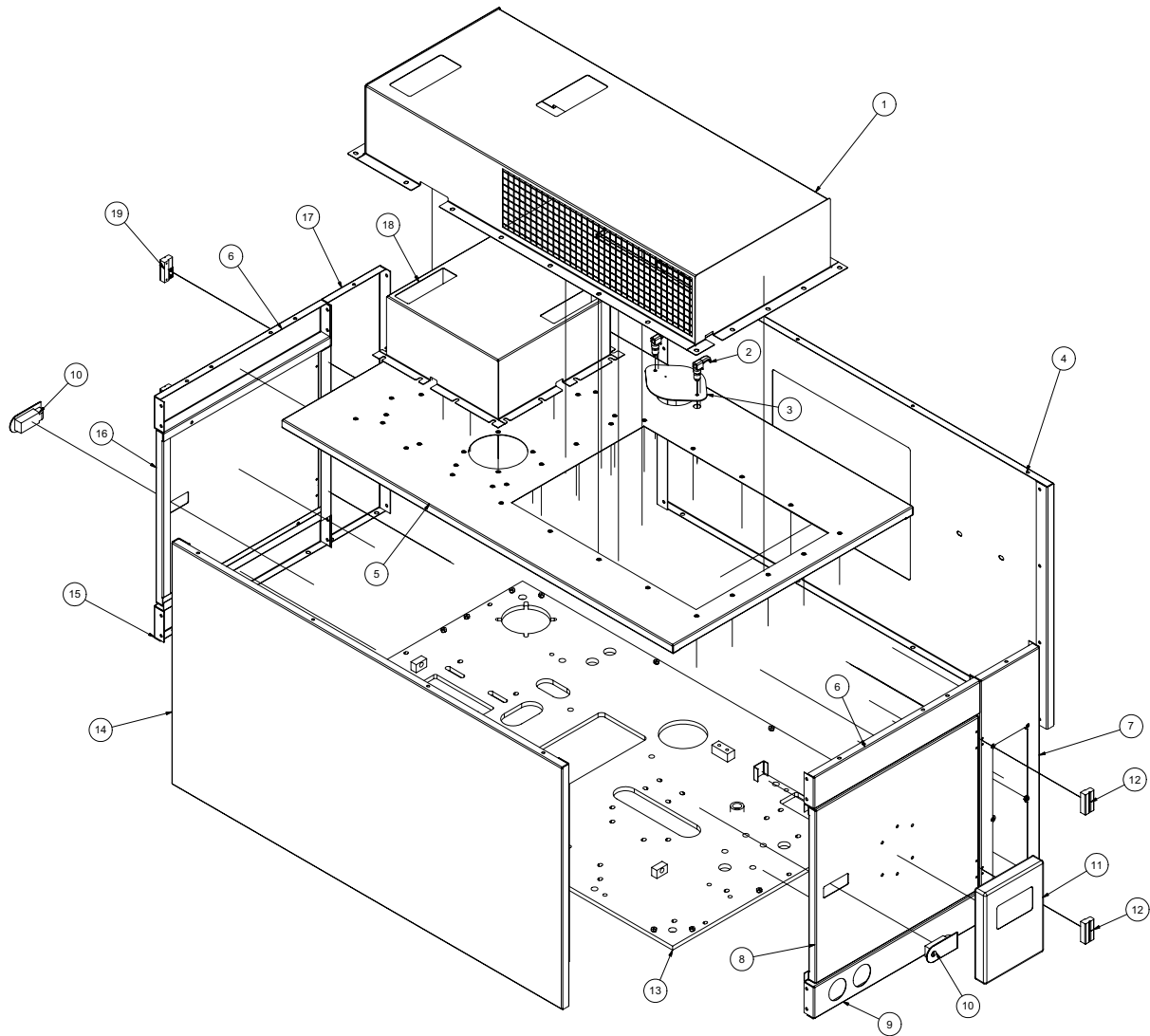

082610-E

VACASSY403

# Enclosure Assembly

# 36 HP

ITEM	QTY	PART NO.	DESCRIPTION
1	1	8044654	INTAKE BOX
2	2	8040334	SWELL LATCH
3	1	8040592	RADIATOR ACCESS COVER
4	1	8043622	PANEL FRONT
*	1	8044888	LF-FRONT SHEET SOUND INSULATION
*	1	8044889	RF-FRONT SHEET SOUND INSULATION
*	1	8044896	ABOVE RADIATOR SOUND INSULATION
*	1	8044936	BELOW RADIATOR SOUND INSULATION
5	1	8044646	PANEL TOP
6	2	8043625	PANEL SIDE UPPER
*	2	8044891	ABOVE/BELOW DOOR SOUND INSULATION
7	1	8043624	PANEL SIDE VERTICAL CONTROL
*	1	8044890	CONTROL PANEL SOUND INSULATION
8	1	8043629	PANEL DOOR W/TRANS MTG BOX
*	1	8044894	RH-DOOR SOUND INSULATION
9	1	8043627	PANEL SIDE LOWER GAUGES
*	1	8044891	ABOVE/BELOW DOOR SOUND INSULATION
10	2	8040586	SEALED LEVER LATCH
	1	8041816	KEY DOOR SOUTHCO LATCH
11	1	E250211	BOX, PLASTIC FOR SAFETY MANUAL
12	2	8040588	OFFSET HINGE TYPE "A"
*	8	U010010	SCREW, HSH #10-32 X .375
13	1	8040889	MAIN PLATE
14	1	8044644	PANEL REAR
*	1	8044893	LS-BACK SHEET SOUND INSULATION
*	1	8044943	RS-BACK SHEET SOUND INSULATION
15	1	8043968	PANEL SIDE LOWER
*	1	8044891	ABOVE/BELOW DOOR SOUND INSULATION
16	1	8043969	PANEL DOOR
*	1	8044895	LH-DOOR SOUND INSULATION
17	1	8043966	PANEL SIDE VERTICAL
*	1	8044892	OPPOSITE CONTROL PANEL SOUND INSULATION
18	1	8044661	EXHAUST SHIELD
19	2	8040589	OFFSET HINGE TYPE "B"
*	8	U010010	SCREW, HSH #10-32 X .375

\* NOT SHOWN

# Enclosure Assembly

# 36HP RC

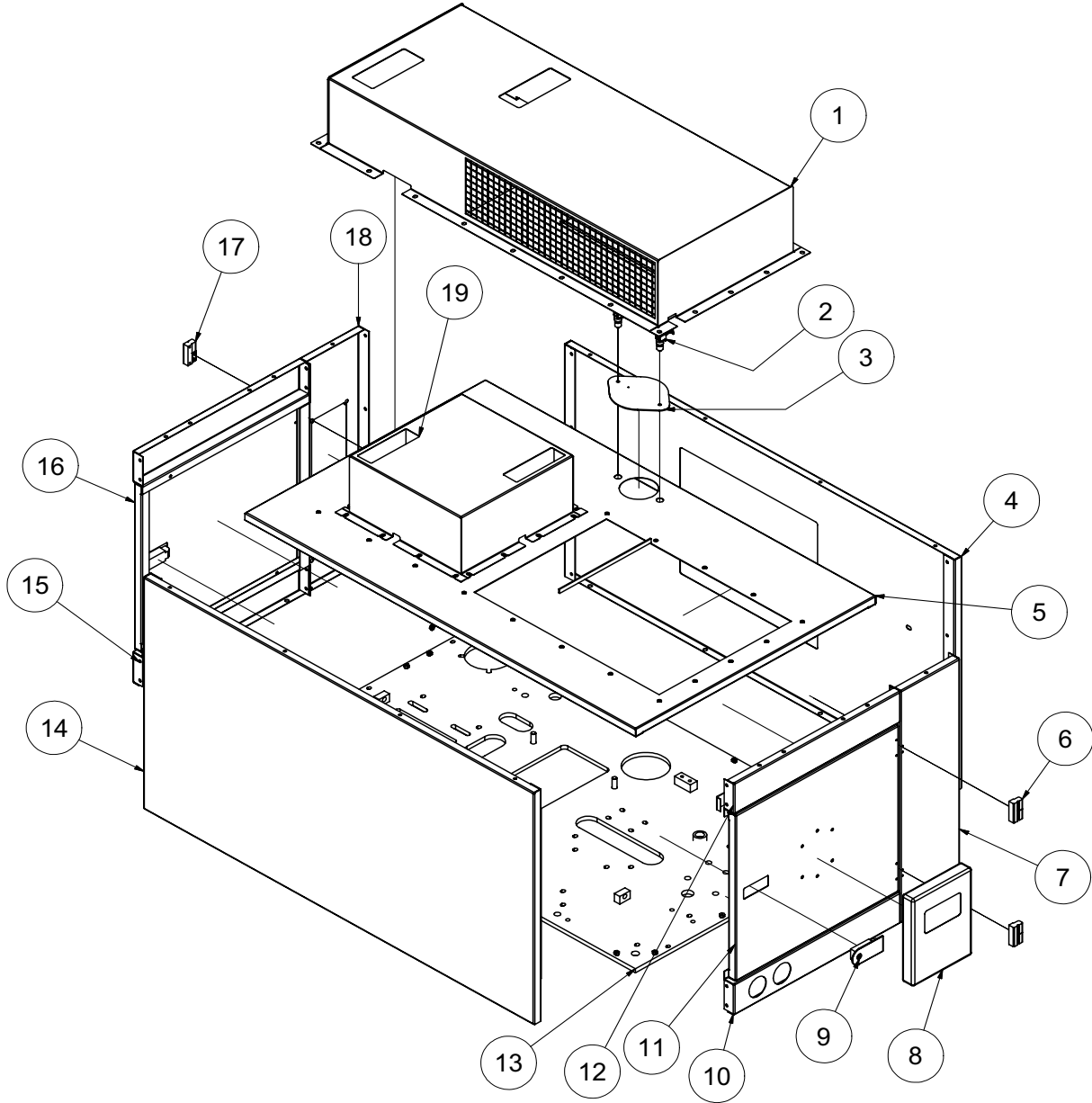



# Enclosure Assembly

## 36HP RC

ITEM	QTY	PART NO.	DESCRIPTION
1	1	8044654	36HS - INTAKE BOX
2	2	8040334	SWELL LATCH
3	1	8040592	ENCLOSURE RADIATOR COVER
4	1	8043622	ENCLOSURE 36VK - PANEL FRONT WELDMENT
*	1	8044888	SOUND INSULATION LF- FRONT SHEET
*	1	8044889	SOUND INSULATION RF- FRONT SHEET
5	1	8044646	ENCLOSURE 36HS - PANEL TOP WELDMENT
6	2	8040588	OFFSET HINGE TYPE "A"
7	1	8043973	ENCLOSURE 36VK - PANEL SIDE VERT. WELDMENT (OPP)
*	1	8044892	SOUND INSULATION OPP. CONTROL SIDE
8	1	E250210	BOX, PLASTIC FOR SAFETY MANUAL
9	2	8040586	SEALED LEVER LATCH
	1	8041816	KEY DOOR SOUTHCO LATCH
10	1	8043627	ENCLOSURE 36VK-PANEL LOWER GAUGES WELDMENT
*	1	8044891	ABOVE / BELOW DOOR SOUND INSULATION
11	1	8043629	36VK PANEL DOOR W/ TRANS MTG BOX
*	1	8044894	RH-DOOR SOUND INSULATION
12	2	8043625	SIDE SHEET, UPPER
	2	8044891	ABOVE / BELOW DOOR SOUND INSULATION
13	1	8040889	MAIN PLATE
14	1	8044644	36HS - PANEL REAR WELDMENT
*	1	8044893	LS - BACK SHEET SOUND INSULATION
*	1	8044943	RS - BACK SHEET SOUND INSULATION
15	1	8043968	36VK PANEL SIDE LOWER WELDMENT
*	1	8044891	ABOVE / BELOW DOOR SOUND INSULATION
16	1	8043969	36VK PANEL DOOR
*	1	8044895	LH - DOOR SOUND INSULATION
17	2	8040589	OFFSET HINGE TYPE "B"
18	1	8043971	36VK PANEL SIDE VERT CONTROL WEDMENT (Opp)
*	1	8044890	CONTROL PANE SOUND INSULATION
19	1	8044661	36HS - EXHAUST SHIELD

# Engine Kubota V1505

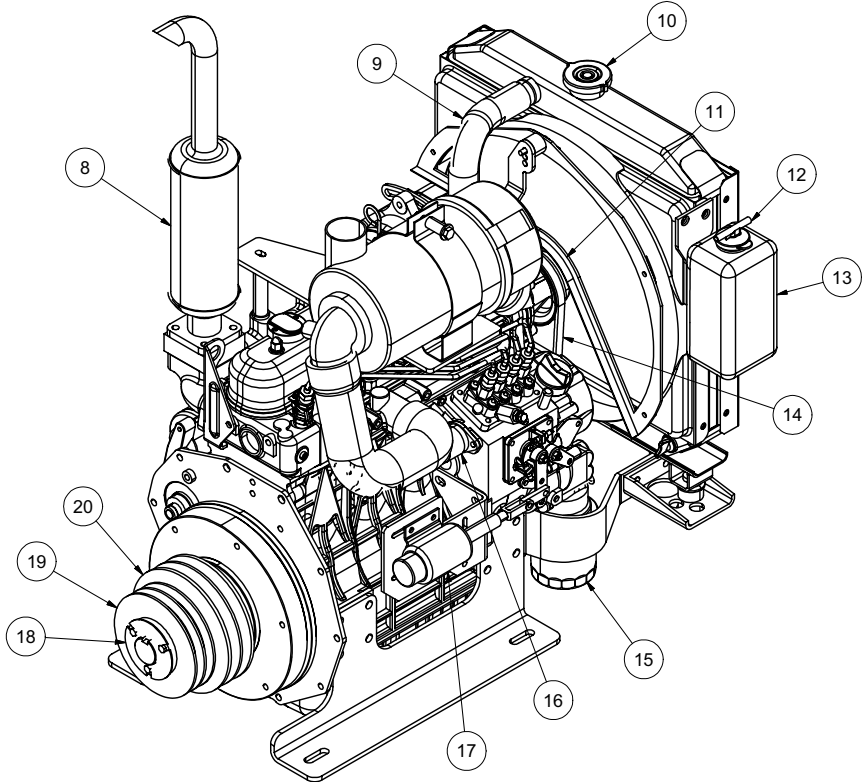
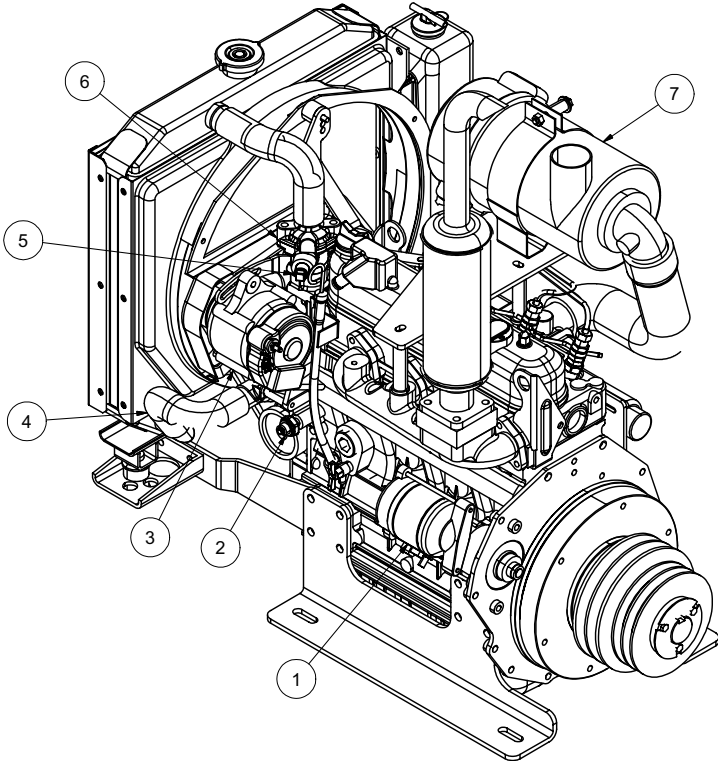

# Engine Kubota V1505

ITEM	QTY	NUMBER	DESCRIPTION
1	1	8043950	STARTER
2	1	8030960	OIL PRESSURE SWITCH
3	1	8030937	ALTERNATOR
4	1	8043951	LOWER RADIATOR HOSE
5	1	8043952	WATER TEMPERATURE SWITCH
6	1	8043953	THERMOSTAT
7	1	8043954	AIR FILTER HOUSING
	1	T700150	AIR FILTER ELEMENT
8	1	8030691	MUFFLER
	2	8031067	MUFFLER GASKET
	1	8031068	MUFFLER SPACER
9	1	8043955	UPPER RADIATOR HOSE
10	1	8043956	RADIATOR CAP
11	1	8043957	FAN
12	1		OVERFLOW TANK CAP (SOLD WITH TANK)
13	1	8043948	OVERFLOW TANK
14	1	8043958	FAN BELT
15	1	T700075	OIL FILTER
16	1	8030966	FUEL SHUTOFF SOLENOID
17	1	8030667	THROTTLE SOLENOID
18	1	8041799	KEYWAY RETAINER
19	1	8030970	SHEAVE, WATER PUMP 2AK34H
	1	8030971	BUSHING 1-7/16" H
20	1	8040484	SHEAVE, BLOWER 6.95"OD 2-GROOVE
	1	8040960	BUSHING 1-7/16" SDS
*	1	T700045	FUEL FILTER
*	1	8043959	FUEL PUMP
*	1	T400106	RADIATOR DRAIN FITTING

\* Not Shown

# Blower Assembly

# 36HP - 575CFM

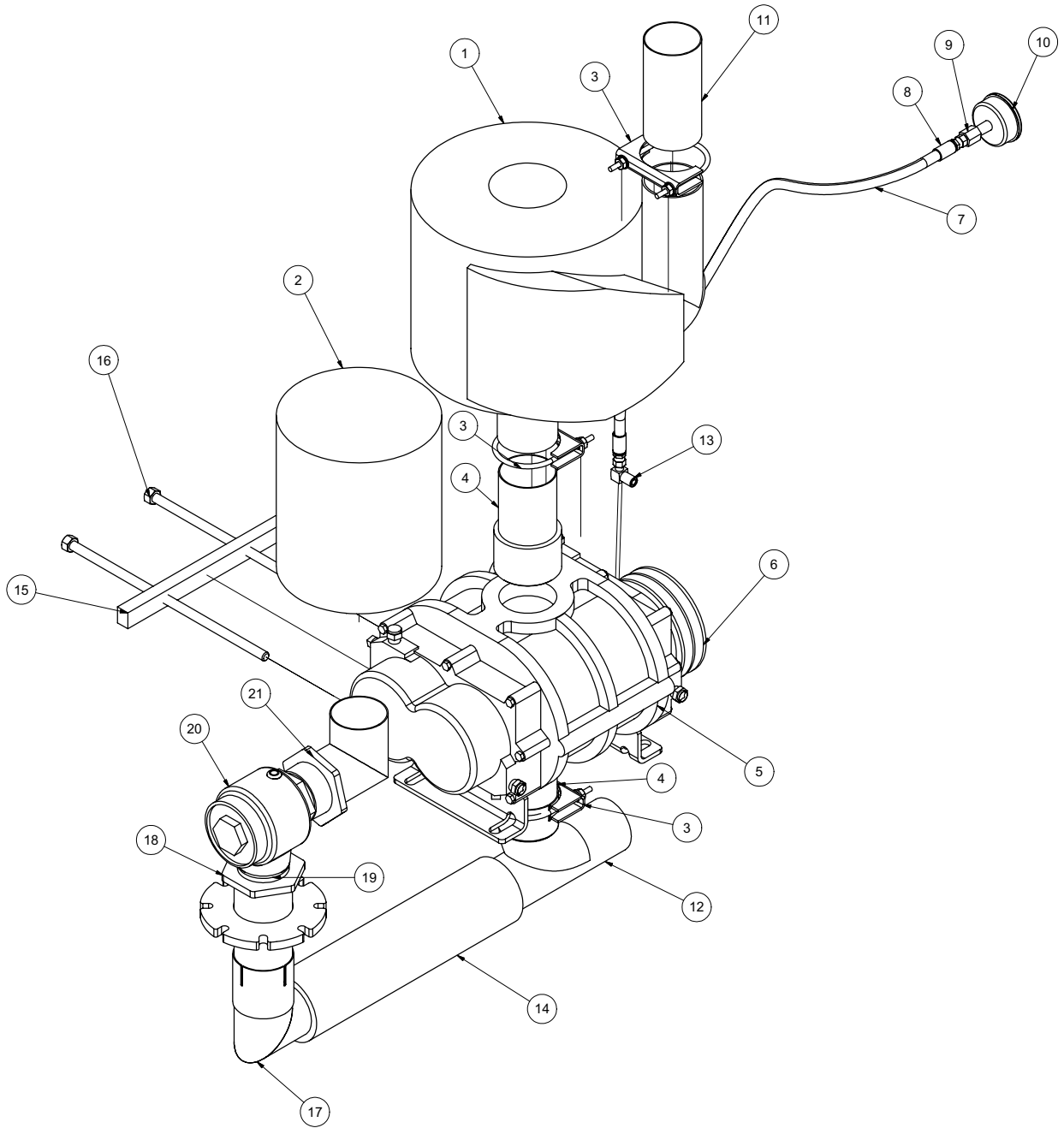

# Blower Assembly

# 36HP - 575CFM

ITEM	QTY	PART NO.	DESCRIPTION
1	1	8030332	SILENCER, 500CFM, COWL
2	1	8043553	FILTER AIR 3" 245CFM
3	3	8030395	3" U-BOLT CLAMP
4	2	8045238	UNION EXHAUST 3" OD-MNPT
5	1	8041250	BLOWER (MODEL 47)
	4	U000817	SCREW, HC 1/2"-13 X 1"
	4	U210100	WASHER, LOCK 1/2"
	4	U200100	WASHER, FLAT 1/2"
6	1	8040945	SHEAVE 595DIA 2 GROOVE
	1	8040642	BUSHING 7/8" SDS
	1	U410042	KEY 3/16" X 3/16" X 2"
	1	8041797	RETAINER
	2	8034158	BX 45 BELT
7	1	8040970	HOSE ASSY VAC 4-70 ST-ST
8	2	T320030	FITTING, HOSE 4HO 4FJ
9	1	8030483	UNION, 4FP 4MJ
10	1	8030371	VACUUM GAUGE
11	1	8030643	EXHAUST TUBE 3"
12	1	8041033	WYE 3" OD STRAIGHT 3" ID BRANCH
13	1	T401100	ELBOW, 4MP - 4MJ 90
14	1	8044107	HOSE VAC KANAFLEX 3" X 7.5"
	2	8042605	CLAMP HOSE T-BOLT 350
15	1	8040702	TENSION BLOCK 575CFM
16	2	8040751	ROD TIGHTENER WELD'T
17	1	8044013	EXHAUST 3" ELBOW TIGHT 90 ID-OD WELD'T
18	1	8044793	BRACKET 36HS VACUUM RELIEF VALVE
19	1	8030409	2" CLOSE NIPPLE
20	1	8030337	KUNKLE VALVE, 575CFM
21	1	8044980	3" ELBOW MFG SHARP W/ 3" X 2" REDUCER

# Blower Assembly

# 36HP - 575CFM RF

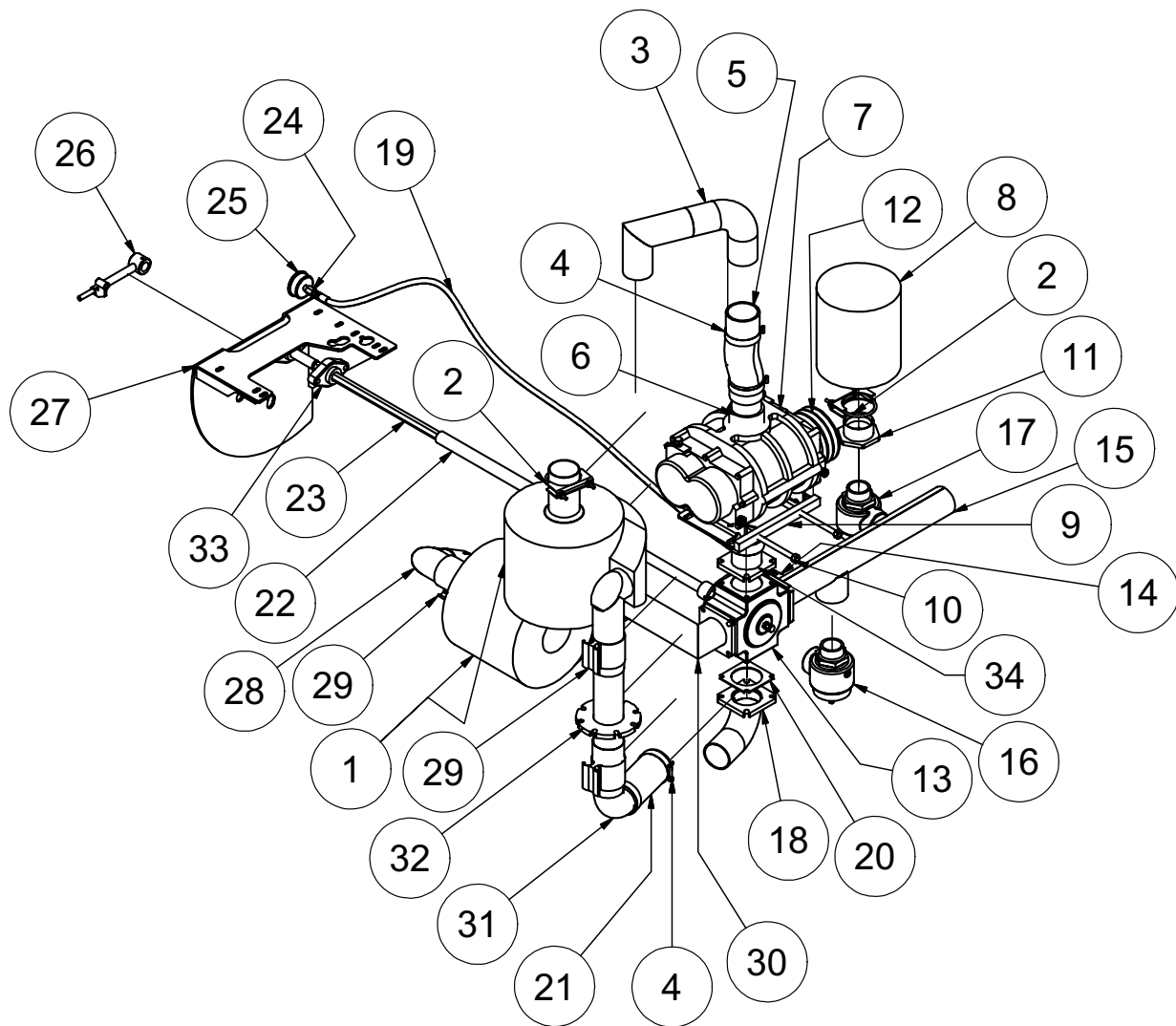

# Blower Assembly

# 36HP - 575CFM RF

ITEM	QTY	PART NO.	DESCRIPTION
1	2	8030332	SILENCER, 500CFM, COWL
2	2	8030395	3" U-BOLT CLAMP
3	1	8044939	3" ELBOW SHARP W/ 3" ELBOW (3"RAD OD-OD) WELD'T
4	4	8042605	CLAMP, T-BOLT 3" (350)
5	1	8044648	HOSE VAC AG SUCTION 3-16
6	1	8045238	UNION EXHAUST 3" OD-MNPT
7	1	8041250	BLOWER, MODEL 47
*	4	U000817	SCREW, HC 1/2" - 13 X 1"
*	4	U210100	WASHER, LOCK 1/2"
*	4	U200100	WASHER, FLAT 1/2"
8	1	8043553	FILTER, AIR 3" 245CFM
9	1	8040702	TENSION BLOCK 575CFM
10	2	8040751	ROD TIGHTENER WELD'T
11	1	8044951	VACUUM RELIEF FILTER BUSHING
12	1	8040945	SHEAVE 595DIA 2-GROOVE
*	1	8043228	BUSHING 7/8" SDS
*	1	U420056	STEP KEY .1875" X .25" X 2.5"
*	1	8041797	RETAINER
*	2	8034158	BX 45 BELT
13	1	8041030	VALVE, 4WAY 3"NPT THREADS
14	1	T402020	UNION, 4MJ - 4MP
15	1	8044901	575RF HEADER WITH FLANGE
16	1	8041034	PRESSURE RELIEF 575
17	1	8030337	KUNKLE VALVE, 575CFM
18	1	8044899	3" ELBOW 90 OD-OD WITH FLANGE 3" - 6"LGS
19	1	8040970	HOSE ASSY VAC 4 - 70 ST - ST
20	4	8044792	GASKET, 4WAY VALVE 3"
21	1	8044649	HOSE VAC AG SUCTION 3 - 18"
22	1	8044362	REV FLOW SHAFT EXT. (LONG) WELD'T
23	1	8044365	REV FLOW SHAFT EXT. (SHORT) WELD'T
24	1	8030483	UNION, 4FP - 4MJ
25	1	8030372	WATER PRESSURE GAUGE 1/4"NPT
26	1	8041617	SPRING PLUNGER HOLDER WELD'T
27	1	8044368	REV FLOW FACEPLATE BRACKET
28	1	8044907	3" ELBOW MFG SHARP 3" OD-OD WITH SLEEVE
29	4	8044914	3" BAND CLAMP
30	1	8044903	ELBOW, 90 SHARP 3" OD-ID WITH FLANGE
31	1	8041813	ELBOW, 3" (3"RAD OD-OD)
32	1	8044910	BRACKET MUFFLER TO MAINPLATE, RF
33	1	W030080	FLANGE BEARING - 2BOLT (1"BORE)
34	1	8044905	ADAPTER 4WAY VALVE (3") TO BLOWER

- NOTES:
- A- INSTALL ITEM #20 (SCREW) IN ASSEMBLY
  - C- 3-1/2 REQ'D SOC. HD. ON G.E. AND D.E.
  - E- REQ'D ON 42 ONLY
  - F- NUT TO BE TORQUED TO:  
 3-1/2---110 LB.FT.  
 4---190 LB.FT.  
 5---250 LB.FT.
  - G- USE RED LOCKTITE ON SET SCREW THREADS.

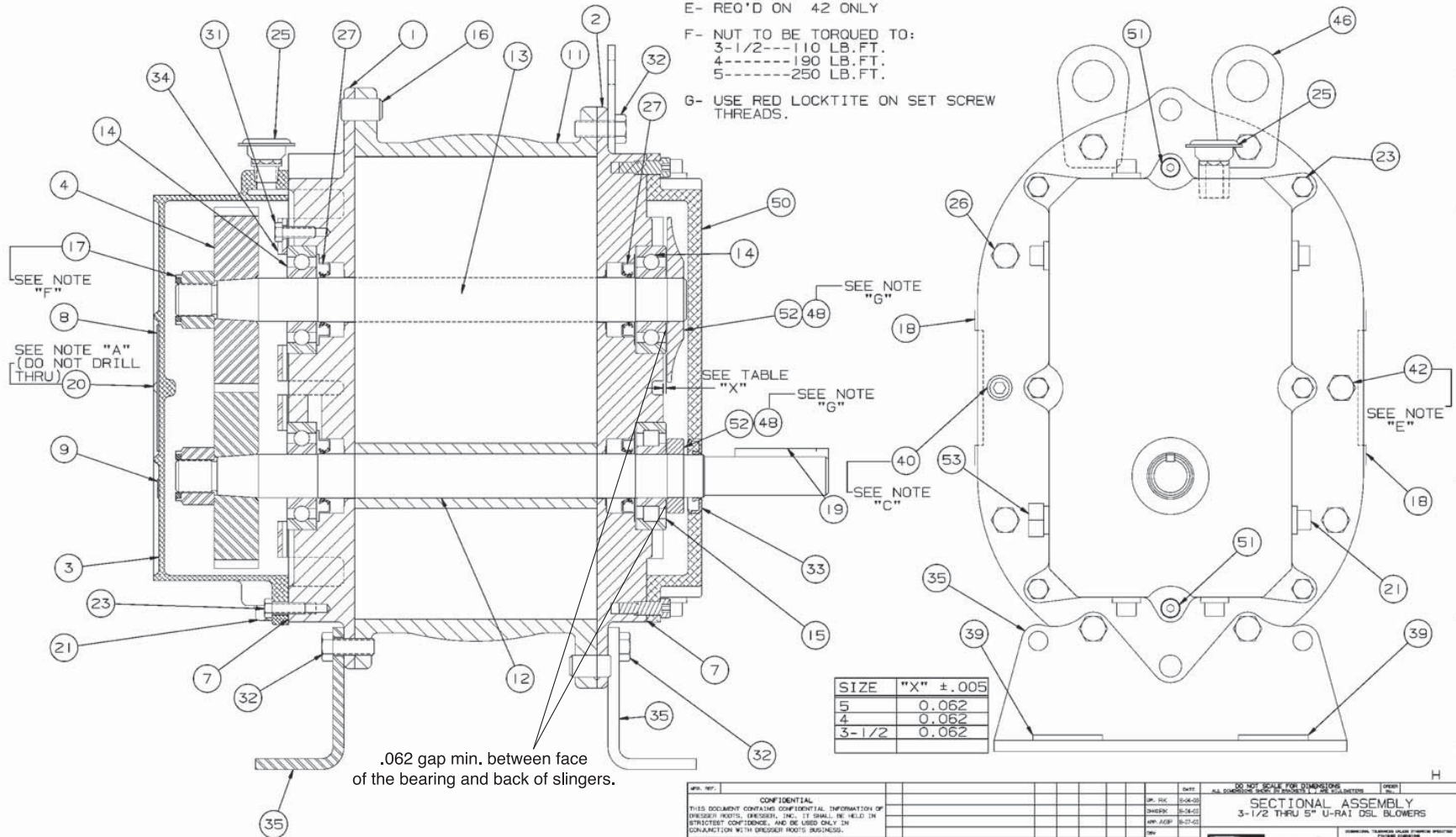

.062 gap min. between face of the bearing and back of slingers.

SIZE	"X" ±.005
5	0.062
4	0.062
3-1/2	0.062

CONFIDENTIAL THIS DOCUMENT CONTAINS CONFIDENTIAL INFORMATION OF DRESSER ROOTE'S. DRESSER, INC. IT SHALL BE HELD IN STRICTEST CONFIDENCE, AND BE USED ONLY IN CONNECTION WITH DRESSER ROOTE'S BUSINESS.		ALL DIMENSIONS UNLESS OTHERWISE SPECIFIED ARE IN INCHES. SECTIONAL ASSEMBLY 3-1/2 THRU 5" U-RAI DSL BLOWERS	
REV. NO.    DATE 1    11/1/08 7:37PM 2    08/11/09 10:00AM 3    08/11/09 10:00AM	DR. RIC    08-08 DMSBK    08-08 MIP ASP    08-08	SCALE: FULL SEE FILE 2 08/08/09	DRESSER ROOTE Houston, TX USA
T30356023    REV A		DRESSER ROOTE	

Assembly of URAI DSL Blowers with Splash Lubricated Drive End 3-5" Gear Diameter



**URAI-DSL Splash Lubricated Blowers  
4" Gear Diameter**

<b>Item #</b>	<b>Qty</b>	<b>Part #</b>	<b>Description</b>
1	1	8041250-1	Headplate Gear End
2	1	8041250-2	Headplate Drive End
3	1	8041250-3	Gearbox
4	2	8041250-4	Timing Gears
7	1	8041250-7	Gasket, Gear Box, DE Cover
11	1	8041250-11	Cylinder
12	1	8041250-12	Impeller & Shaft Drive
13	1	8041250-13	Impeller & shaft Driven
14	3	8041250-14	Bearing, Ball
15	1	8041250-15	Bearing, Roller
16	4	8041250-16	Pin, Dowel
17	2	8041250-17	Gear Nut
19	1	8041250-19	Key
21	3	8041250-21	Plug, Pipe
23	6	8041250-23	Screw Hex
25	1	8041250-25	Breather (Plug Vent)
26	*	8041250-26	Screw, Hex
27	4	8041250-27	Seal, Lip Bearing
31	4	8041250-31	Screw, Hex, Nylock
32	6	8041250-32	Screw, Hex
33	1	8041250-33	Seal Lip-Drive
34	2	8041250-34	Clamp Plate
35	2	8041250-35	Foot
39	4	8041250-39	Washer Mounting
40	2	8041250-40	Screw Socket
42	2	8041250-42	Screw Hex
48	4	8041250-48	DE Oil Slinger Set Screw
50	1	8041250-50	Drive End Cover
52	2	8041250-52	Drive End Oil Slinger
53	2	8041250-53	Oil Sight Glass

\*Quantities vary by blower.

# Water Pump Assembly

# TS2021

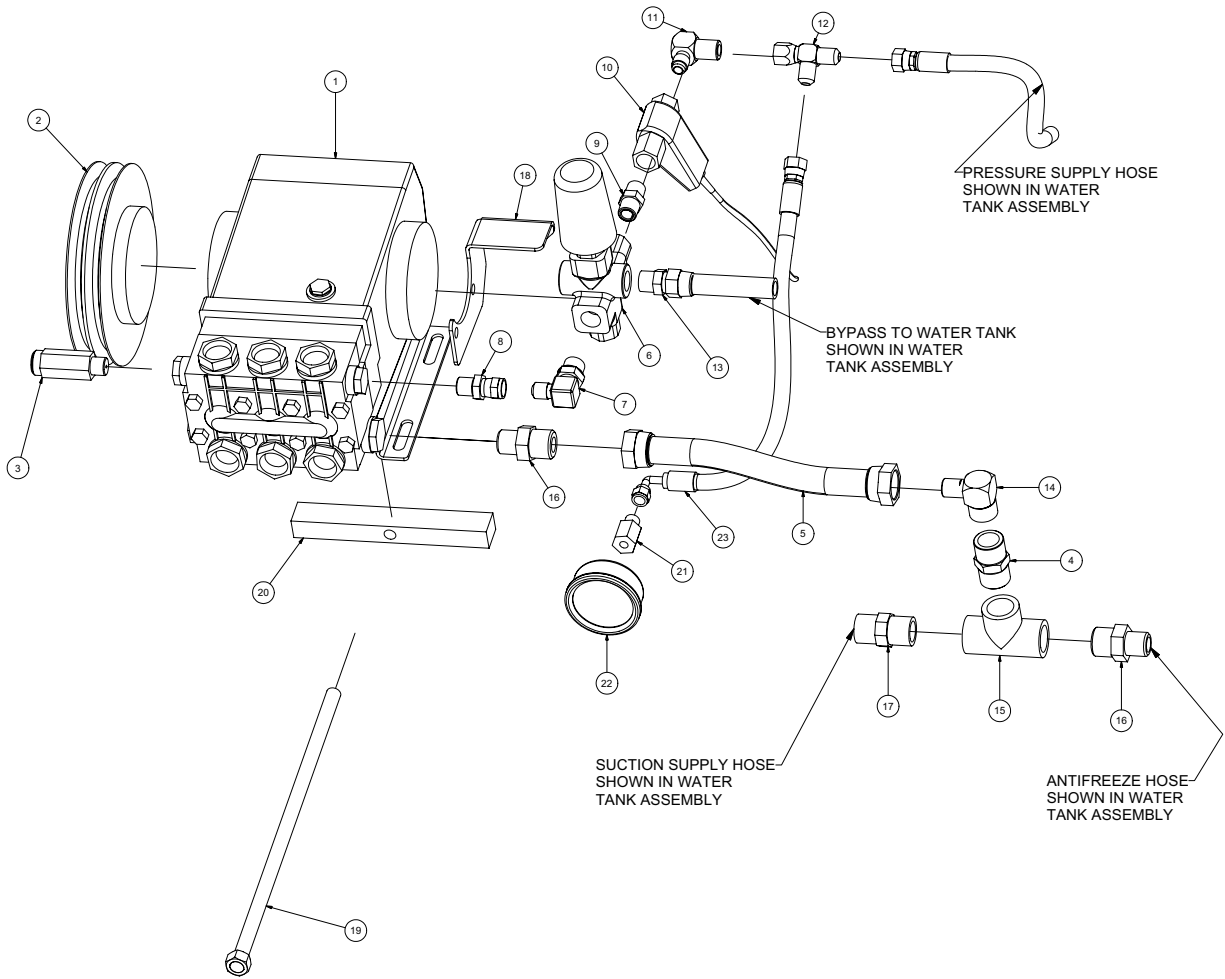

# Water Pump Assembly

# TS2021

ITEM	QTY	PART NO.	DESCRIPTION
1	1	8031279	WATER PUMP
	4	U000420	SCREW, HC 3/8"-16 X 1"
	4	U210060	WASHER, LOCK 3/8"
	4	U200600	WASHER, FLAT 3/8"
2	1	8030961	WATER PUMP CLUTCH
	1	U410094	KEY 5/16" X 5/16" X 1 3/8"
3	1	8030340	SAFETY RELIEF VALVE 6GPM
4	1	T400080	REDUCER 12MP-8MJ
5	1	8040972	HOSE VAC PUSH 12-8 1/2
	2	8030525	FITTING, HOSE #12FJ PUSH LOCK
6	1	8040177	VALVE, UNLOADER, PULSAR 3
7	1	T401140	ELBOW, 90 1/2"MP-1/2"MJ
8	1	T401125	REDUCER, 3/8MP-1/2FJ
9	1	T400805	UNION, 3/8 MP - 3/8 MP
10	1	8031267	FLOW SWITCH
11	1	T401102	ELBOW, 90 6MJ-6MP
12	1	T402153	TEE 6MJ 6MJ 6FJ
13	1	T400030	REDUCER, 6MP 8MJ
14	1	T401160	ELBOW, 90 3/4 MJ - 1/2 MJ
15	1	T402160	TEE, 3/4FP-3/4FP-3/4FP
16	2	T400080	REDUCER, 12MP 8MJ
17	1	T400100	UNION, 12MP 12MJ
18	1	8043859	WATER PUMP FILTER BRACKET
19	1	8040751	ROD TIGHTENER WELD'T
20	1	8040893	TENSIONER BLOCK, ADJUSTING
21	1	T400110	UNION, 1/4FP-1/4MJ
22	1	8030372	WATER PRESSURE GAUGE 1/4NPT
23	1	8044125	HOSE VAC PUMP TO GAUGE 4-24 ST-90
*	2	8041803	BELT, AX 47 (67/73HP)
	2	8034157	BELT, AX 39 (36HP)
	2	8041082	BELT, AX 48 (99HP COMP 1025 CFM)
	2	8040876	BELT, AX 45 (49HP)

\* NOT SHOWN

# Water Pump TS2021

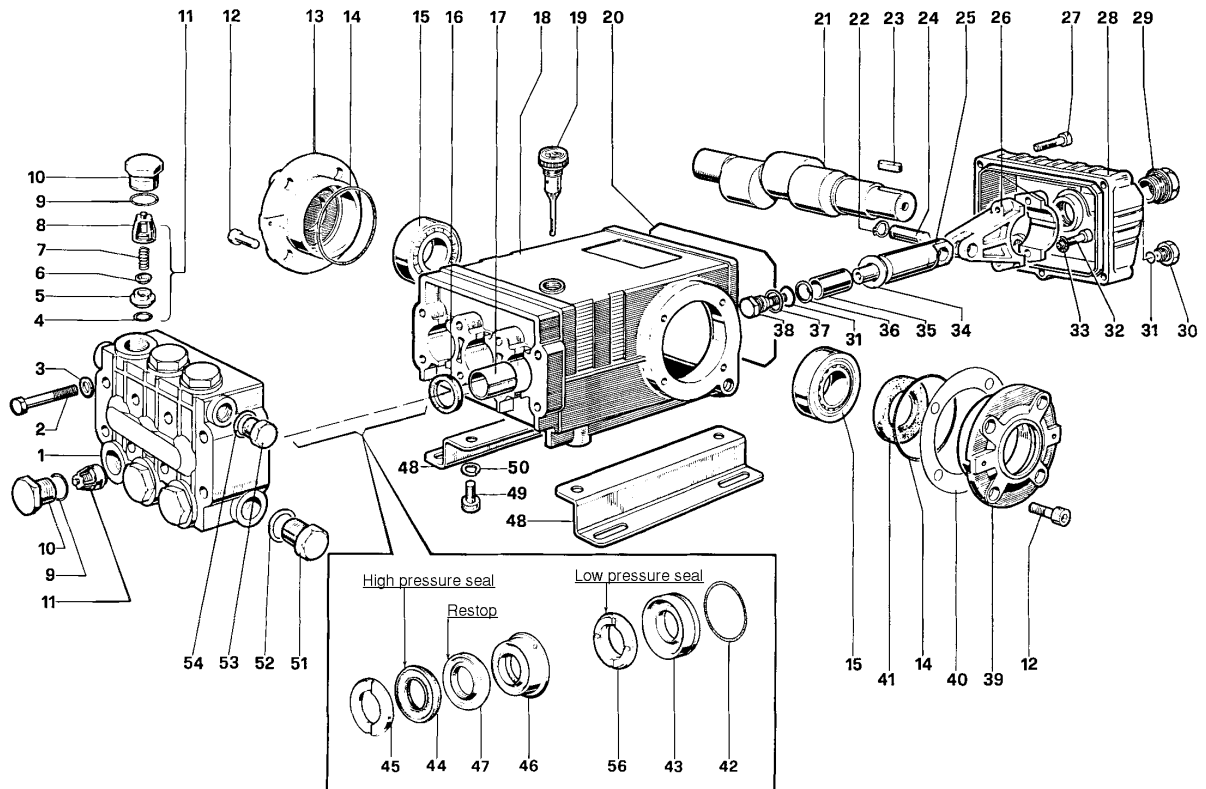

## TORQUE SPECS\*

\*Decrease torque by 20%  
if threads are lubricated

Position	Ft. Lbs.	N-M
2	22.1	29.9
10	73.7	99.9
12	14.7	19.2
27	7.3	9.9
29	13.2	17.9
30	14.7	19.2
32	14.7	19.2
38	14.7	19.2
49	29.4	39.8
51	29.4	39.8
53	29.4	39.8

VACASSY325

# Water Pump TS2021

ITEM	QTY.	PART #	DESCRIPTION	KIT #	ITEM #'S INCL'D IN KIT	NO. OF ASSY IN KIT	NO. OF CYL KIT WILL SERVICE
1	1	8031280-1	Manifold	8031280-KIT1	4, 5, 6, 7, 8 (11)	6	3
2	8	8031280-2	Screw, M8 x 70	8031280-KIT2	16	3	3
3	8	8031280-3	Washer, M8 x 4	8031280-KIT3	41	2	0
4	8	8031280-4	O-ring, .674 x .103	8031280-KIT4	9, 10	6	3
5	6	8031280-5	Seat, Valve	8031280-KIT5	9, 10	6	3
6	6	8031280-6	Plate, Valve	8031280-KIT6	31, 34	3	3
7	6	8031280-7	Spring		36, 37, 38		
8	6	8031280-8	Guide, Valve	8031280-KIT7	45	6	3
9	6	8031280-9	O-ring, .797x.103	8031280-KIT10	42, 43	3	3
10	6	8031280-10	Cap	8031280-KIT28	42, 43, 44,	1	1
11	6	8031280-11	Valve Assembly		45, 45, 47, 56		
12	8	8031280-12	Screw, M8 x 16	8031280-KIT69	44, 47, 56	3	3
13	1	8031280-13	Cover, Crankcase	8031280-KIT71	46, 47	3	3
14	2	8031280-14	O-ring, 2.675 x .103				
15	2	8031280-15	Bearing, Roller				
16	3	8031280-16	Seal, Oil				
17	3	8031280-17	Bushing				
18	1	8031280-18	Crankcase				
19	1	8031280-19	Oil Dip Stick				
20	1	8031280-20	O-ring, Cover				
21	1	8031280-21	Crankshaft				
22	6	8031280-22	Ring, Snap				
23	1	8031280-23	Key				
24	3	8031280-24	Pin, Wrist				
25	3	8031280-25	Guide, Plunger				
26	3	8031280-26	Rod, Connecting				
27	5	8031280-27	Screw, M6 x 30				
28	1	8031280-28	Cover, Crankcase				
29	6	8031280-29	Oil Indicator				
30	1	8031280-30	Cap				
31	4	8031280-31	O-ring, .426x.070				
32	6	8031280-32	Screw, M8 x 35				
33	6	8031280-33	Washer, M8.4				
34	3	8031280-34	Washer, M14				
35	3	8031280-35	Plunger (20 mm)				
37	3	8031280-37	Washer				
38	3	8031280-38	Screw, Plunger				
39	1	8031280-39	Cover, Crankcase				
40	2	8031280-40	Shim				
41	1	8031280-41	Seal, Oil				
42	3	8031280-42	O-ring, 1.364x.070				
43	3	8031280-43	Retainer, Packing				
44	3	8031280-44	Packing				
45	3	8031280-45	Ring, Head, M20				
46	3	8031280-46	Intermed. Ring				
47	3	8031280-47	Testop Ring				
48	2	8031280-48	Pump Feet				
49	4	8031280-49	Screw, M10 x 18				
50	4	8031280-50	Washer, M10.2				
51	1	8031280-51	Cap				
52	1	8031280-52	Washer, M21.5				
53	1	8031280-53	Cap				
54	1	8031280-54	Washer, M17.5				
56	3	8031280-56	Seal,Low Press,20mm				

VACASSY325

# Unloader Valve YU2140

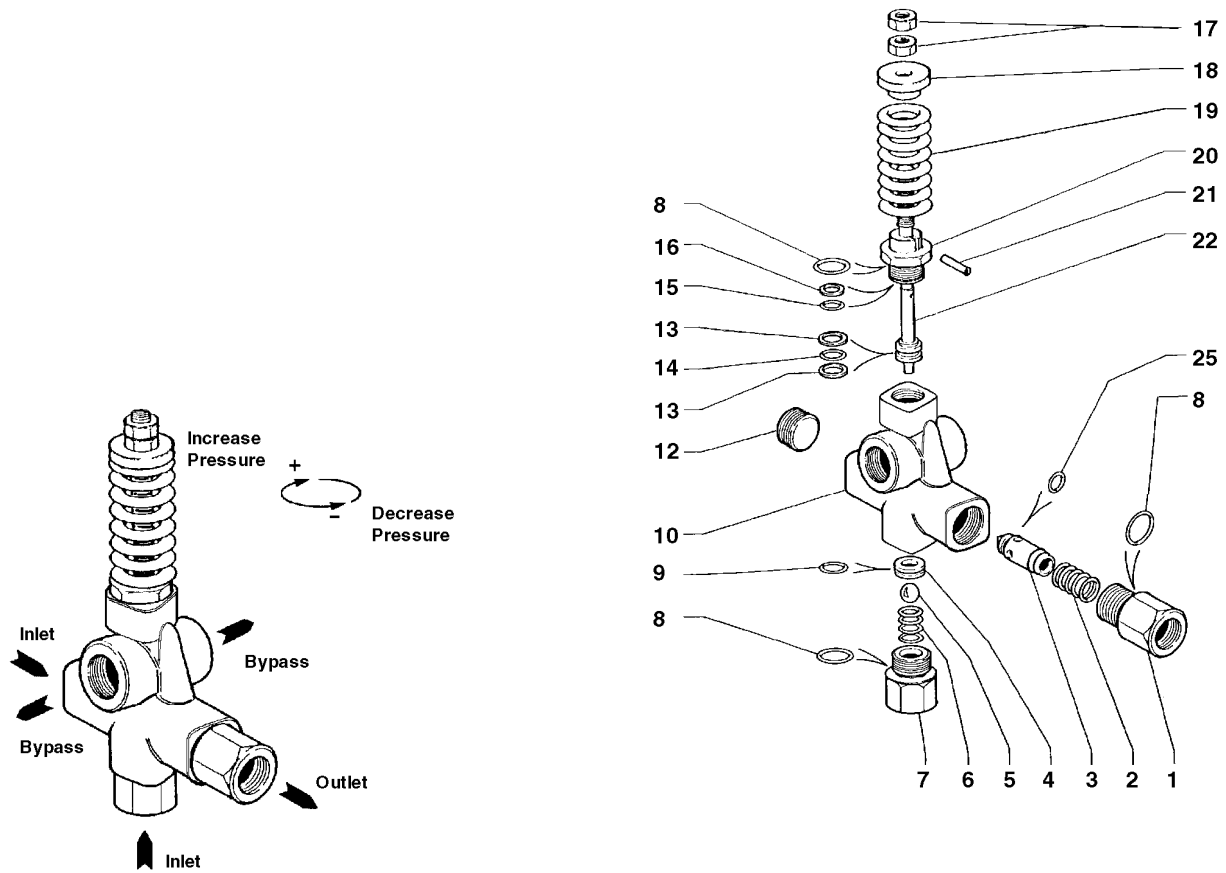

# Unloader Valve YU2140

ITEM	QTY	PART #	DESCRIPTION
1	1	8030341-1	OUTLET CONNECTION
2	1	8030341-2	SPRING
3	1	8030341-3	CHECK VALVE
4	1	8030341-4	SEAT
5	1	8030341-5	SS BALL
6	1	8030341-6	SPRING
7	1	8030341-7	INLET CONNECTION
8	2	8030341-8	O-RING
9	1	8030341-9	O-RING
10	1	8030341-10	VALVE HOUSING
12	1	8030341-12	PLUG
13	2	8030341-13	BACK RING
14	1	8030341-14	O-RING
15	1	8030341-15	O-RING
16	1	8030341-16	BACK RING
17	1	8030341-17	NUT
18	1	8030341-18	SPRING GUIDE
19	1	8030341-19	SPRING-GREEN (YU2140)
20	1	8030341-20	PISTON HOUSING
21	1	8030341-21	PIN
22	1	8030341-22	PISTON
25	1	8030341-25	O-RING

# Electrical Control Bracket

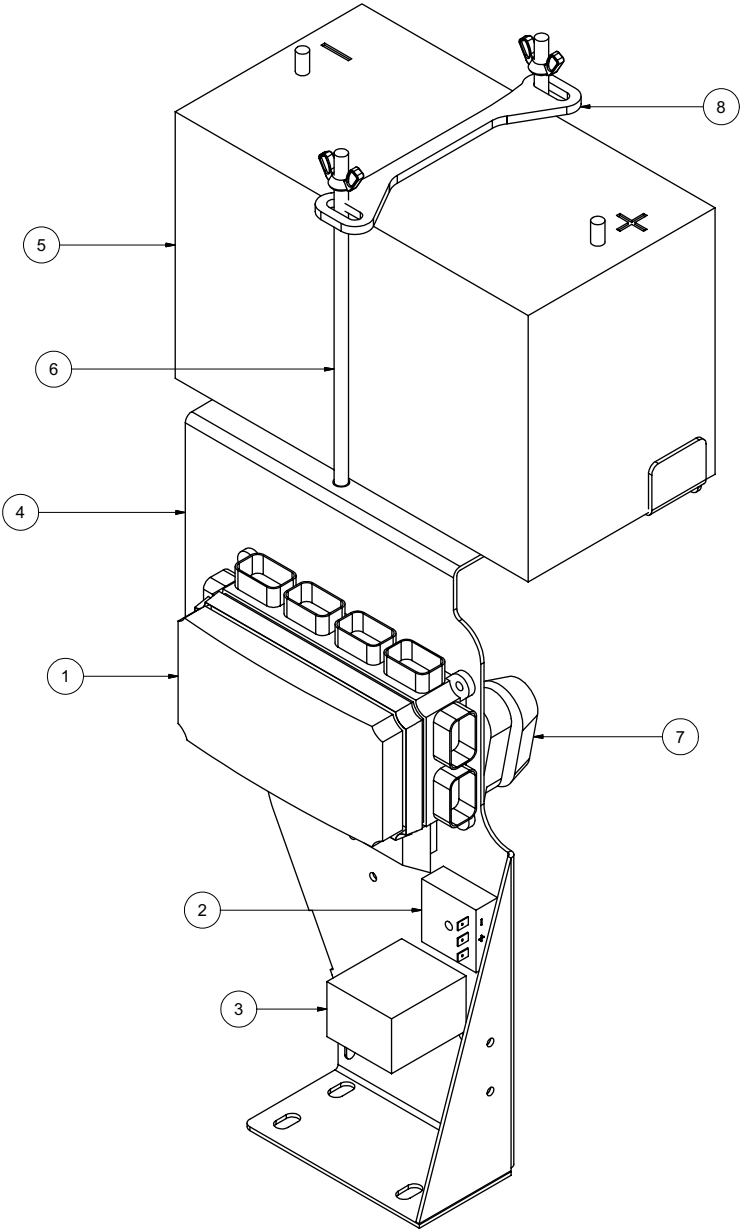



# Electrical Control Bracket

ITEM	QTY	PART NO.	DESCRIPTION
1	1	X000213	BUSSMAN VEC
	7	X000205	FUSE 5A
	2	X000206	FUSE 10A
	2	X000207	FUSE 20A
	3	X000237	FUSE 30A
	1	X000236	CIRCUIT BREAKER 20A
	1	X000210	CIRCUIT BREAKER 30A
	6	X000209	RELAY 35A/25A
	5	X000208	DIODE 6A
2	1	8042282	SWITCH, DELAY RELAY
3	1	X000240	RELAY TIME 30 SECOND
4	1	8043127	CONTROL PANEL - HARNESS MTG PLATE
5	1	X400050	BATTERY, 31-MHD WORKAHOLIC
6	2	8043742	BATTERY HOLD DOWN ROD ASSY
7	1	8043800	FUSE HOLDER AMG
	1	8043801	FUSE 250A AMG
8	1	8050016	BATTERY HOLD DOWN
*	1	X200005	HARNESS VAC CONTROL
*	1	X300222	BATTERY GROUND CABLE
*	1	X300219	BATTERY HOT CABLE 18"
*	1	X300220	ENGINE TO FUSE HOT 1GA 60"
*	1	X300221	HYD PUMP TO FUSE HOT 1GA 36"
*	1	X300221	ELEC CONTROL BOX TO FUSE HOT 1GA 36"
*	1	X300222	ELEC CONTROL BOX GROUND 1GA 18"
*	1	X300224	ENGINE GROUND 1GA 21"
*	1	X300225	HYD PUMP GROUND 1GA 24"

\* NOT SHOWN

# Control Panel

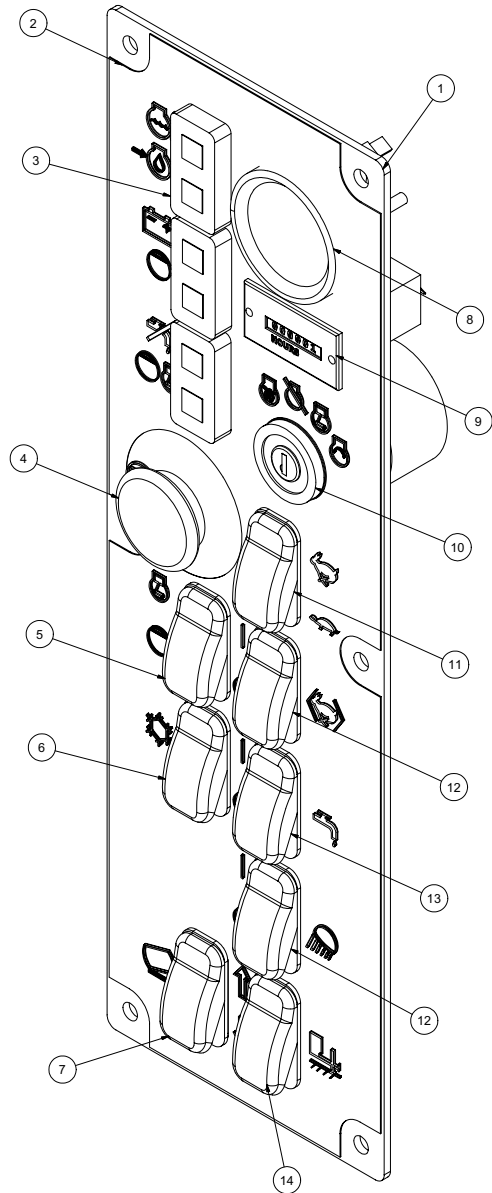
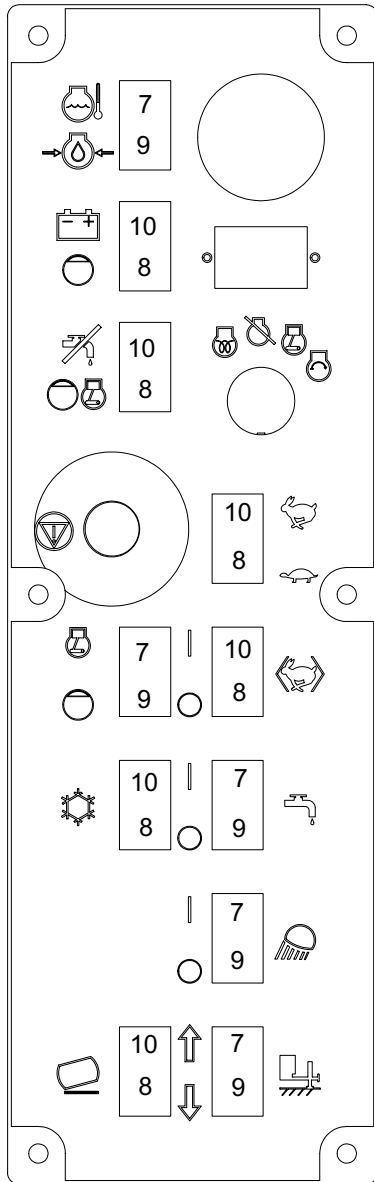

# Control Panel

ITEM	QTY	PART NO.	DESCRIPTION
1	1	8043128	CONTROL PANEL - MAIN PLATE
2	1	J200031	DECAL - CONTROL PANEL
3	3	X000260	LIGHT LED DUAL PANEL
4	1	X000280	E-STOP
5	1	X000273	ROCKER SWITCH SPST (ON) NONE -OFF
6	1	X000272	ROCKER SWITCH DPST (ON) NONE -ON
7	1	X000274	ROCKER SWITCH DPDT (ON) OFF (ON)
8	1	X100001	FUEL GAUGE
9	1	X000300	HOUR METER
10	1	8030458	IGNITION SWITCH
11	1	X000271	ROCKER SWITCH DPST ON - ON
12	2	X000270	ROCKER SWITCH SPST ON -OFF
13	1	X000270	ROCKER SWITCH SPST ON -OFF
	1	X000271	ROCKER SWITCH DPST ON -ON
14	1	X000290	ROCKER SWITCH PLUG
	1	X000274	ROCKER SWITCH DPDT (HYD. JACK OPTION)
*	1	8030829	KEY, IGNITION - KUBOTA

\* NOT SHOWN

# Hydraulic Pump w/ Bracket

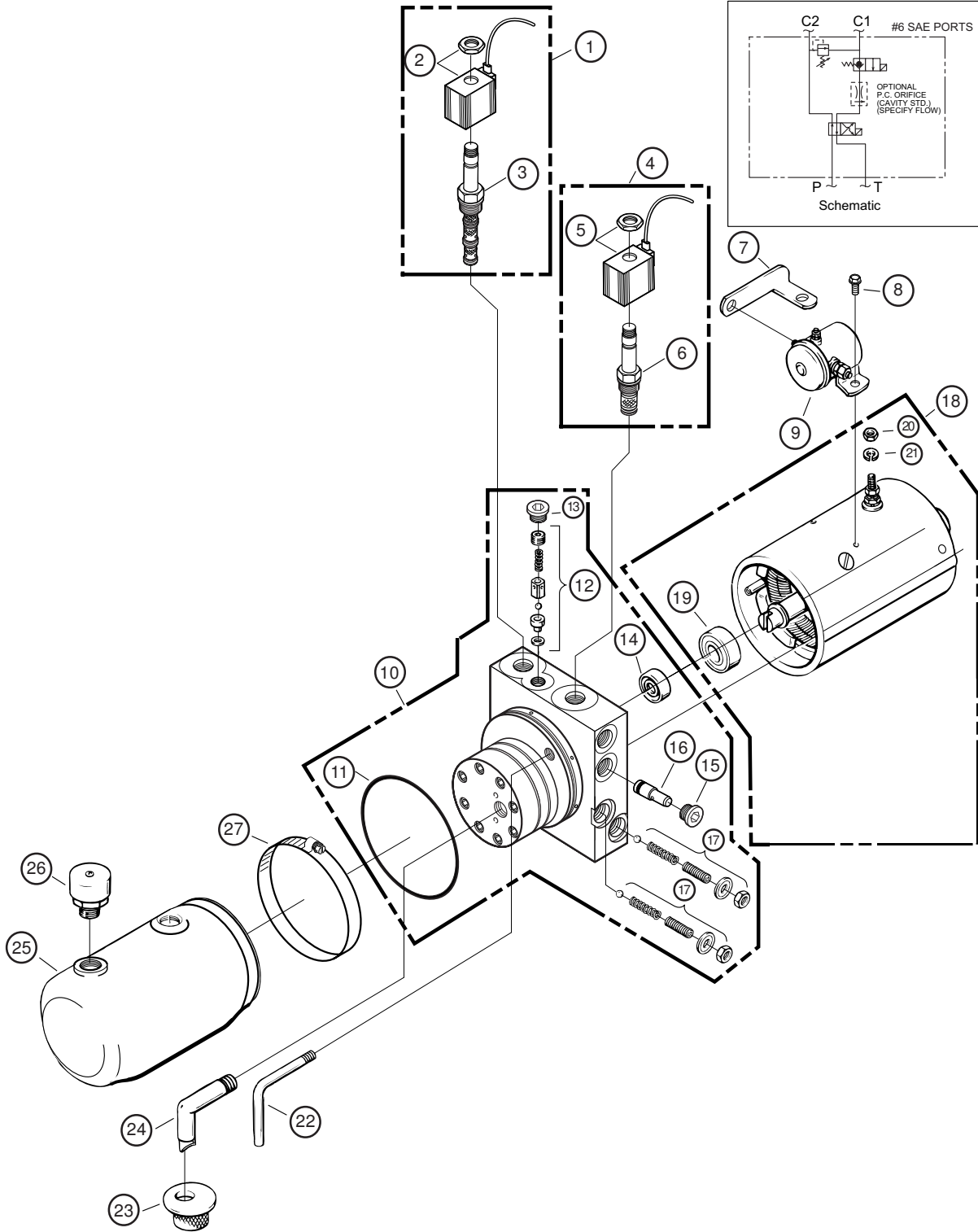

# Hydraulic Pump w/ Bracket

ITEM	QTY	NUMBER	DESCRIPTION
	1	8040486	HYDRAULIC PUMP 12V 3QT
		8045355	HYDRAULIC PUMP 12V 6QT (HYDRAULIC DOOR OPTION)
	2	U000420	SCREW, HC 3/8"-16 X 1
	2	U210060	WASHER, LOCK 3/8"
	2	U200600	WASHER, FLAT 3/8"
	2	T400037	UNION 6MB-6MJR
	2	8040973	HOSE ASSY VAC 6-20 ST-90
	2	T400391	BULKHEAD 6MP 6MP
1	1	8041601-14	VALVE, 4 WAY - 2 POSITION (12V)
2	1	8041601-15	COIL, 10 VDC GROUNDED W/DEUTSCH CONN
3	1	8041601-16	CARTRIDGE, 4 WAY - 2 POSITION
4	1	8041601-17	VALVE, 2 WAY - 2 POSITION (12V) GROUNDED
5	1	8041601-18	COIL, 10 VDC, 2 WAY-2 POS GRND W/DEUTSCH CONN
6	1	8041601-19	VALVE 12V HYD 2 WAY-2 POS
7	1	8041601-20	STRAP, MOTOR SOLENOID CONNECTING
8	2	8041601-21	SCREW, RND HD MACH 10-32 X 1/4"
9	1	8041601-22	SWITCH, SOLENOID 12VDC, 3 POST GRND
10	1	8041601-23	PUMP ASSY
11	1	8041601-24	O-RING INDUST 3-5/8 X 3-7/8 X 1/8
12	1	8041601-25	PARTS KIT-VALVE ASSY, POPPET/BALL CHECK
13	1	8041601-26	PLUG
14	1	8041601-27	SEAL
15	1	8041601-28	PLUG, #8 SAE
16	1	8041601-29	VALVE, PRESS, COMP ORIFICE
17	2	8041601-30	PARTS KIT, RELIEF VALVE
18	1	8041601-31	MOTOR, ELECTRIC 12 VDC
19	1	8041601-32	BEARING, BASE, MOTOR
20	1	8041601-33	NUT, HEX 5/16-24
21	1	8041601-34	WASHER, LOCK 5/16"
	2	8041601-38	SCREW, HEX HEAD, 1/4-20 X 1-3/8"
	1	8041601-41	PLUG, 3/8" NPTF
22	1	8041601-42	TUBE, RETURN (1/8")
23	1	8041601-43	SCREEN, FILTER (SUCTION)
24	1	8041601-44	TUBE, FILTER SUCTION 3/8 NPT 90 DEG
25	1	8041601-45	6QT RESEVOIR POLY
	*	8040486-45	3QT RESEVOIR POLY
	*	8041601-48	4.5QT RESEVOIR POLY
26	1	8041601-46	PLUG, VENT, 3/8" NPT
27	1	8041601-47	CLAMP, HOSE WORM GEAR (IN SERIES)
*	1	X200002	HYDRAULIC PUMP WIRE HARNESS
*	1	8043499	HYDRAULIC PUMP MOUNT
		8044297	HYDRAULIC PUMP MOUNT (REVERSE FLOW)
		8045336	HYDRAULIC PUMP MOUNT (412 BLOWER)

\* NOT SHOWN

# Water Tank Assembly

# 50Gallon Saddle Tanks

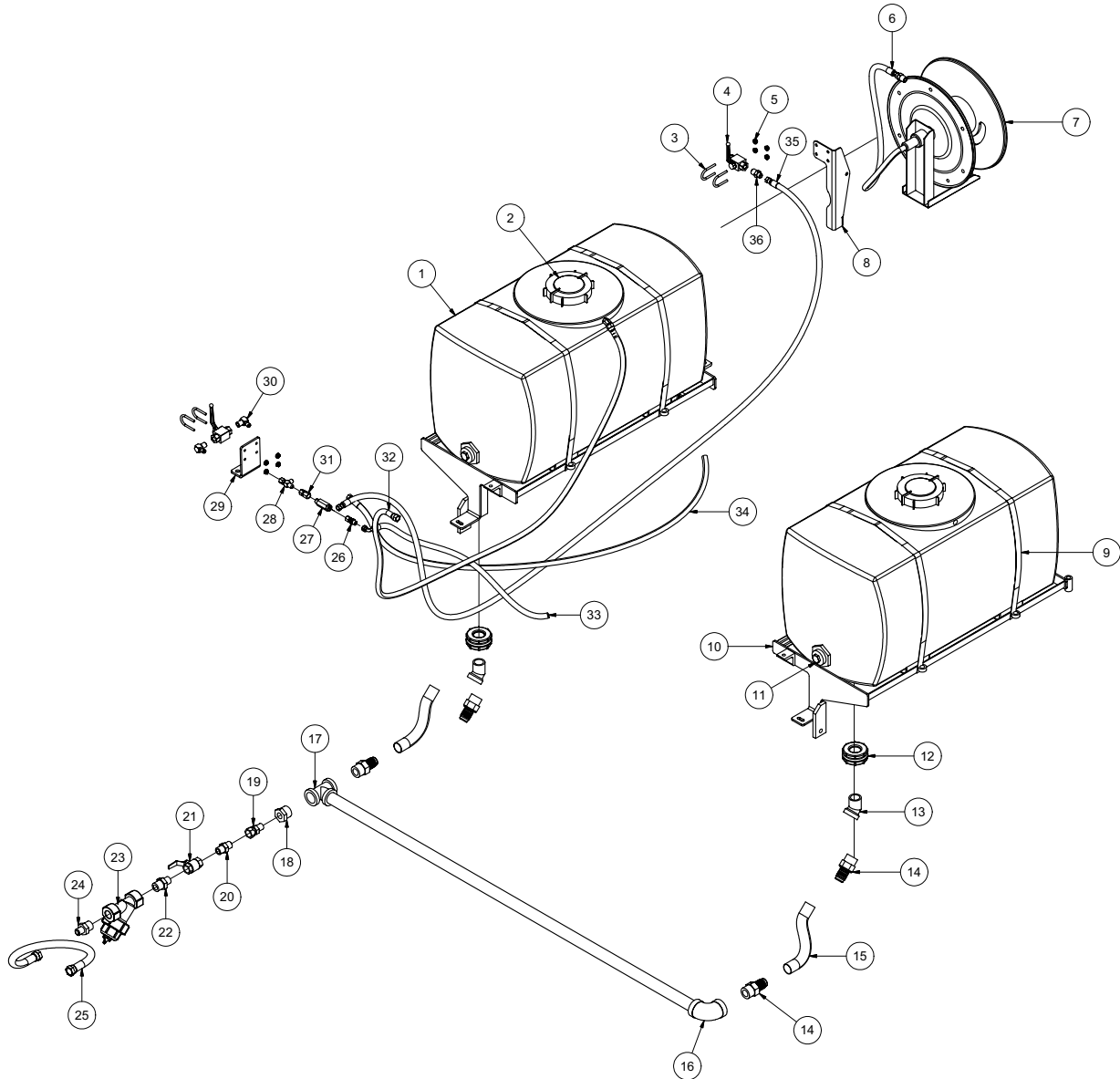

# Water Tank Assembly 50Gallon Saddle Tanks

ITEM	QTY	PART NO.	DESCRIPTION
1	2	8034151	50 GALLON WATER TANK
2	2	8034151-1	TANK LID
3	4	U010017	U-BOLT 1 1/2" X 1/4-20
4	2	8030351	BALL VALVE, STEEL 6FP
5	8	U120100	NUT, LOCK 1/4-20
	8	U200020	WASHER, FLAT 1/4"
6	1	8042412	HOSE REEL SUPPLY HOSE
7	1	8043927	HOSE REEL SP 3/8"
	4	U000420	SCREW, HC 3/8"-16X1.0
	8	U200060	WASHER, FLAT 3/8"
	4	U210060	WASHER, LOCK 3/8"
	4	U100060	NUT, HEX 3/8"-16
	1	8041830	HOSE 3/8" X 30'
	*	8030842-100	HOSE 3/8" X 100' (OPTIONAL)
	1	8030526	QUICK DISCONNECT 1/4" FEMALE
	1	8030504	REDUCER 3/8"FP - 1/4"MP
8	1	8043094	HOSE REEL BRACKET
9	4	8043758	STRAP, EYEBOLT 1" X 55" OAL
10	2	8040952	SADDLE FRAME
11	2	T405065	PLUG, 3/4" MP
12	2	8041044	BULKHEAD, 1 1/4" FNPT - PLASTIC
13	2	8041526	ELBOW, 45 1-1/4" STREET
14	4	8041312	FITTING, HOSE BARB 1 1/4"
15	2	8042940	HOSE VAC CLEAR VINYL 1 1/4-18
16	1	8041309	ELBOW, 1 1/4FP-1 1/4FP
17	1	8041310	TEE, 1 1/4FP-1 1/4FP-1 1/4FP
18	1	T403100	REDUCER, 20MP-12FP
19	1	T400101	UNION, 12FJ-12MP
20	1	T400100	UNION, 12MJ-12MP
21	1	T000185	BALL VALVE, BRASS 3/4" FP
22	1	T404060	UNION, 16MP-12MP
23	1	8040186	STRAINER
	1	8040186-1	END CAP
	1	8040186-2	GASKET
	1	8040186-3	STRAINER PLUG
	1	8040186-4	FKM O
	1	8040186-5	STRAINER MESH SCREEN 80
	1	8040186-6	Y-BODY
	1	8040186-7	EPDM O-RING
24	1	T400450	UNION, 12MJ-16MP
25	1	8041058	HOSE VAC PUSH 12-36
	2	8030525	FITTING, HOSE #12FJ PUSH LOCK
	1	8030518	1/2" BULKHEAD 45 DEG
26	1	8031126	REDUCER, 1/4"FP - 3/8"MJ
27	1	8030340	SAFETY RELIEF VALVE
28	1	T402153	TEE 6MJ-6MJ-6FJ
29	1	8040670	BALL VALVE BRACKET
30	2	T401102	ELBOW 6MJ 6MP
31	1	8031125	UNION 4FP 6FJ
32	1	8041059	HOSE VAC PUSH 8-66
	2	8030524	1/2" PUSH LOCK FITTING
33	1	8043664	BALL VALVE TO WATER PUMP HOSE #6-36 ST-90
34	1	8043949	BALL VALVE TO TANK CLEANOUT HOSE #6-215 ST-90
35	1	8041477	HOSE REEL TO BALL VALVE HOSE #6-140 ST-ST
36	1	T400803	UNION, 6MP-6MJ

# Water Tank Assembly

# 205 Gallon Saddle Tanks

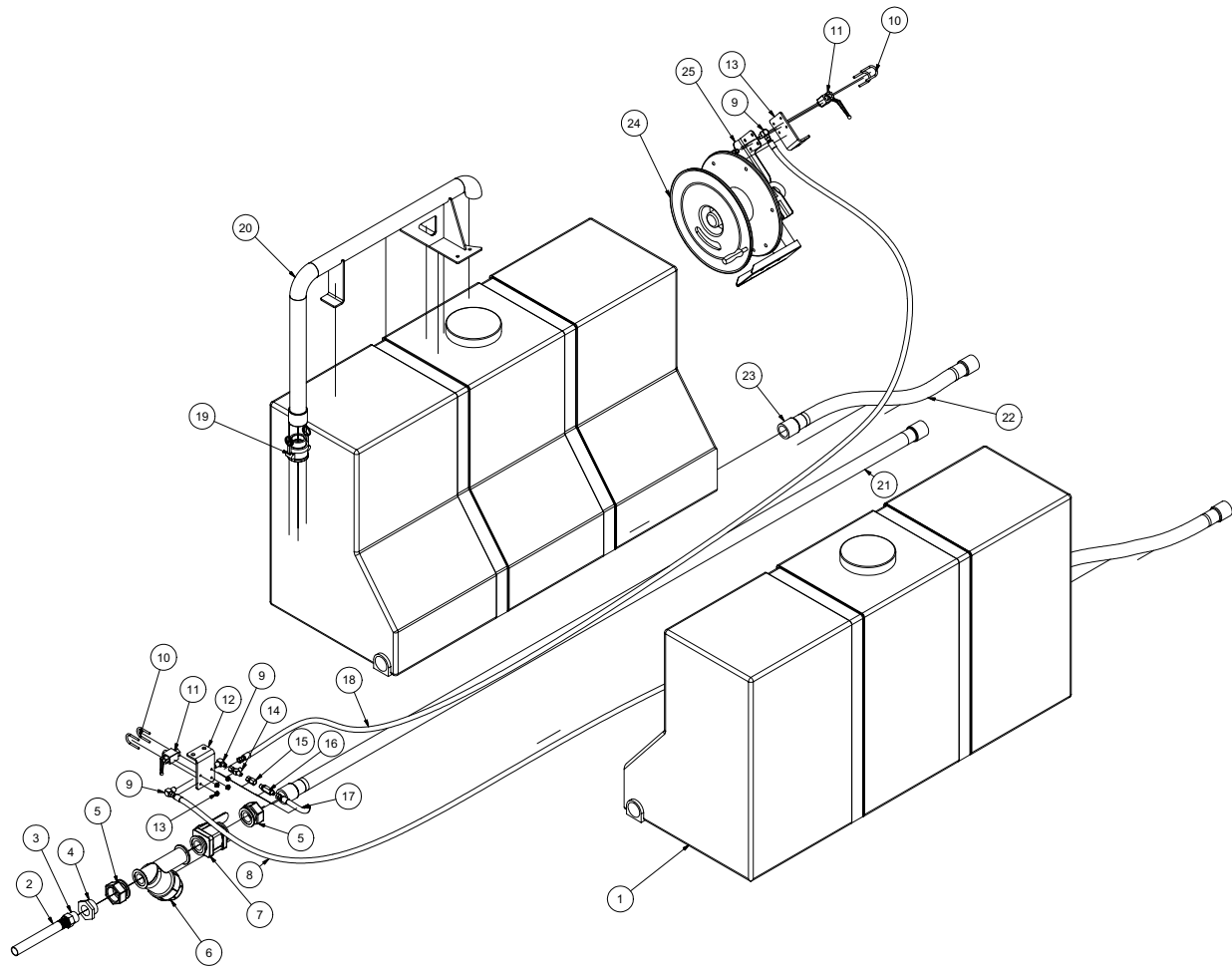



# Water Tank Assembly

# 205 Gallon Saddle Tanks

ITEM	QTY	NUMBER	DESCRIPTION
1	2	8043805	TANK, WATER 205 GAL. POLY.
*	1	8030518	1/2" BULKHEAD 45 DEG
2	1	8043076	HOSE VAC CLEAR VINLY 1 1/4-37"
3	1	8044266	FITTING HOSE BARB 20HB-20MP
4	1	8043843	REDUCER, 1 1/4"MP - 1/2"FP GALV
5	2	8030996	ADAPTER, FEMALE 2"
6	1	8031001	Y-STRAINER, 2"
7	1	8030998	BALL VALVE, BANJO 1 1/2"ID
8	1	8043949	BALL VALVE TO TANK CLEAN OUT HOSE #6-215 ST-90
	2	T320040	FITTING, HOSE 6HO-6FJ
9	4	T401102	ELBOW, 6MJ-6MP
10	4	U010017	1 1/2" CLAMP HOOK 1/4-20 THD
11	2	8030351	STEEL BALL VALVE, 3/8" NPT
12	2	8040670	BALL VALVE BRACKET
13	8	U120142	NUT, LOCK FLANGED .250-20 G2
	8	U200020	WASHER, FLAT 1/4"
14	1	T402153	TEE, 6MJ-6MJ-6FJ
15	1	8031125	UNION, 4FP-6FJ
16	1	8030923	FILTER, WATER HIGH PRESSURE
17	1	8043664	BALL VALVE TO WATER PUMP HOSE #6-36 ST-90
18	1	8041477	HOSE REEL TO BALL VALVE HOSE #6-140 ST-ST
	2	T320040	FITTING, HOSE 6HO-6FJ
19	1	8031219	COUPLING, 2" ALUM MP X FCAMLOCK
20	1	8044398	QUICK FILL 205 GAL
21	1	8045635	HOSE VAC CLEAR VINLY 2"-122
	2	8043397	CLAMP VAC CLEAR HOSE 2"
22	2	8045636	HOSE VAC CLEAR VINLY 2"-36
	2	8043397	CLAMP VAC CLEAR HOSE 2"
23	6	T410115	HOSE BARB 2"
24	1	8043927	HOSE REEL
25	1	8043094	WATER HOSE VALVE BRACKET
26	1	8045386	SWITCH, WATER TANK BOTTOM LONG

\* NOT SHOWN

# Antifreeze Assembly

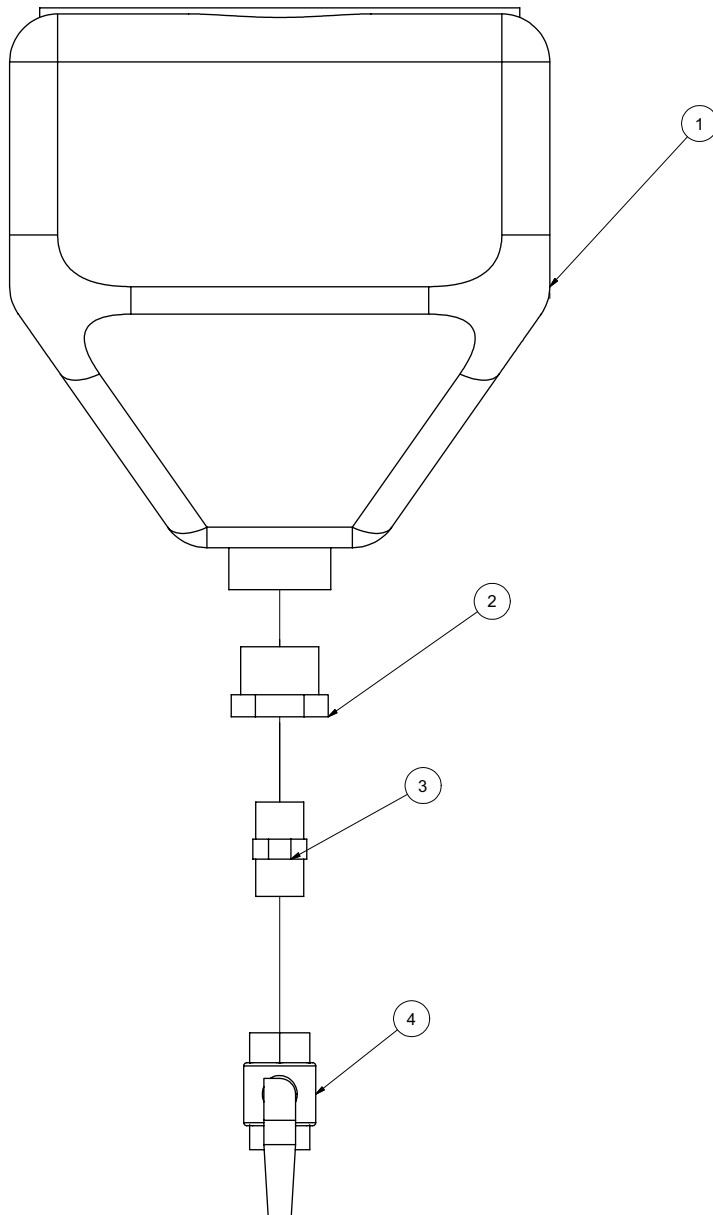

# Antifreeze Assembly

ITEM	QTY	PART NO.	DESCRIPTION
1	1	8030394	ANTI-FREEZE TANK 4 GAL.
	4	U000180	SCREW, HC .312 -18 X .750
	4	U200040	WASHER, FLAT 5/16"
	4	U210040	WASHER, LOCK 5/16"
2	1	T400585	REDUCER, 20MP-12FP
3	1	T400800	UNION, 12MP-12MP
4	1	T000185	BALL VALVE, BRASS 3/4" FP

# Hose Reel Assembly

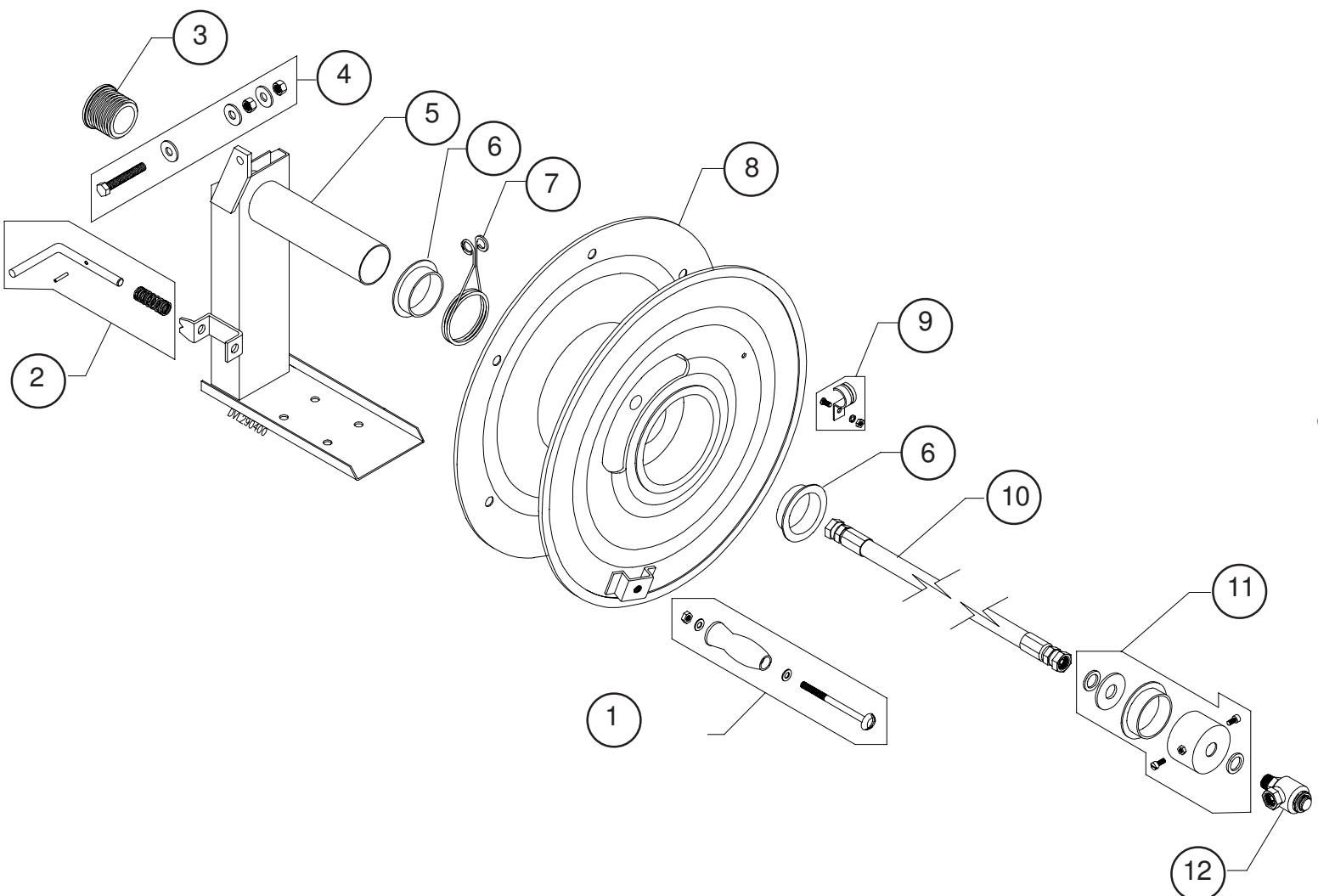

072208

VACASSY751

# Hose Reel Assembly

ITEM	QTY	NUMBER	DESCRIPTION
	1	8043927	HOSE REEL, SP 3/8" X 150'
1	1	8043927-1	KIT-HOSE REEL HANDLE W/HARDWARE
2	1	8043927-2	KIT-LOCKING LATCH AND SPRING
3	1	8043927-3	KIT-HOSE GUIDE
4	1	8043927-4	KIT-SCREW, WASHER, BOLT SET
5	1	8043927-5	KIT-BASE
6	1	8043927-6	KIT-BUSHINGS (2)
7	1	8043927-7	KIT-BREAKING SPRING
8	1	8043927-8	KIT-REEL
9	1	8043927-9	KIT-HOSE CLAMP AND SCREW SET
10	1	8042412	HOSE VAC ASSY 6-33 ST-ST FNPT
11	1	8043927-11	KIT-SWIVEL MOUNTING COLLAR
12	1	8043927-12	KIT-3/8" HIGH PRESSURE SWIVEL 5000 PSI

# Trailer Assy 518

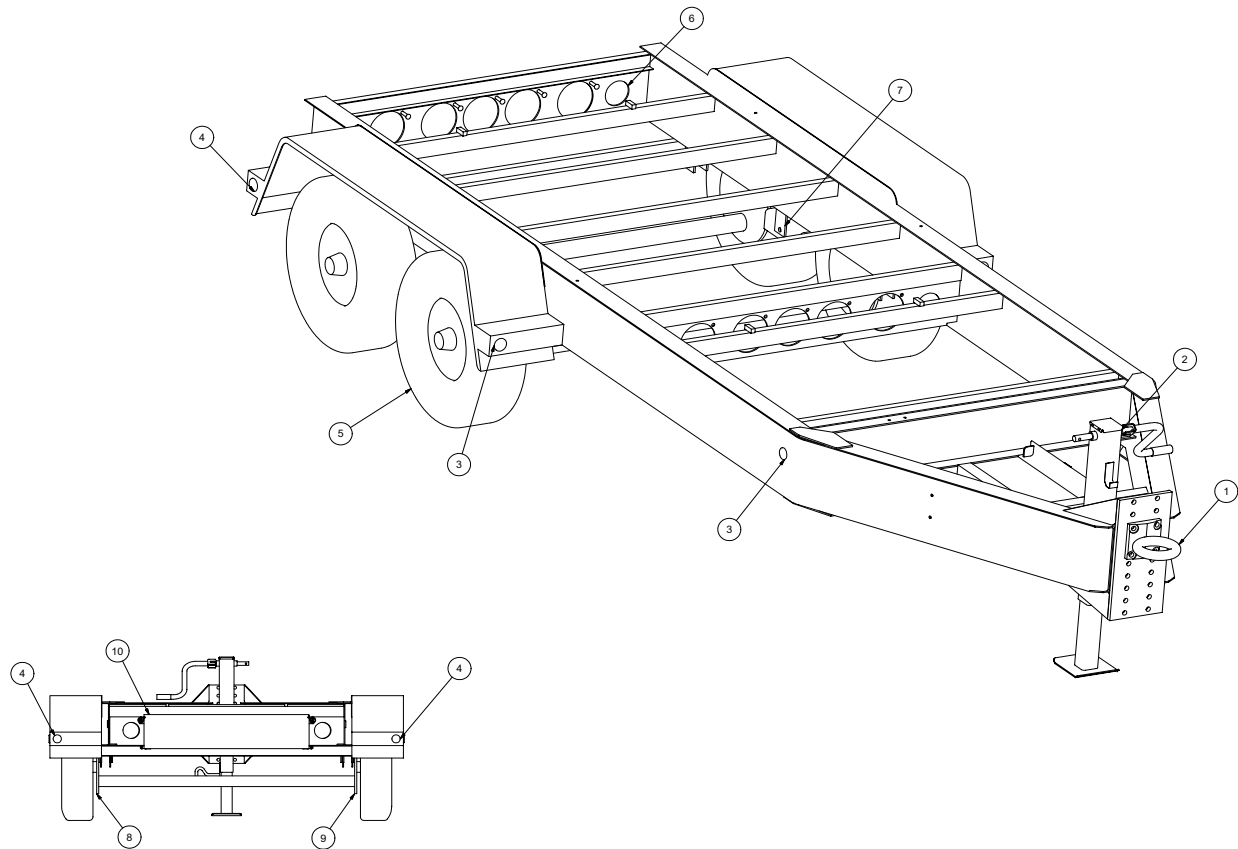

# Trailer Assy 518

ITEM	QTY	PART #	DESCRIPTION
1	1	8045366	4 BOLT PINTLE EYE
2	1	8043548	JACK - MANUAL
	1	8043984	JACK - HANDLE
		8043653	JACK - HYDRAULIC (OPTIONAL)
3	4	8044000	2" YELLOW MARKER LIGHT
	4	8044002	2" RUBBER GROMMET
4	4	8043999	2" RED MARKER LIGHT
	4	8044002	2" RUBBER GROMMET
5	4	8045370	TIRE, ST215 X 75 R 17.5
	4	8045369	WHEEL
	2	8045371	AXLE
	4	8045372	HUB
	32	8043987	LUG NUT
	4	8047429	GREASE CAP W/ O-RING & PLUG
6	2	8044327	TAILGATE 514/518
7	4	8045373	SPRING
	8	8045374	U-BOLT NUT
	8	8045375	U-BOLT
	4	8045376	TIE PLATE
8	1	8045377	LH BRAKE ASSEMBLY
	2	8045379	MAGNET KIT
	2	8045380	SHOE KIT
	1	8045381	ADJUSTER KIT
9	1	8045378	RH BRAKE ASSEMBLY
	2	8045379	MAGNET KIT
	2	8045380	SHOE KIT
	1	8045381	ADJUSTER KIT
10	1	8044809	TAILGATE WELDMENT
	2	U340050	PIN LINCH 3/16" X 1 9/16
	2	U000420	SCREW, HEX 3/8"-16 X 1.25
	4	U200600	WASHER, FLAT 3/8"
*	1	8043981	SAFETY CHAIN
*	1	8043982	BREAKAWAY SWITCH
*	1	8043983	BREAKAWAY BATTERY
*	1	8044008	BREAKAWAY BOX
*	1	8044007	6-WAY PLUG
*	1	8046994	SPARE TIRE

\* NOT SHOWN

# Skid Assembly

V500

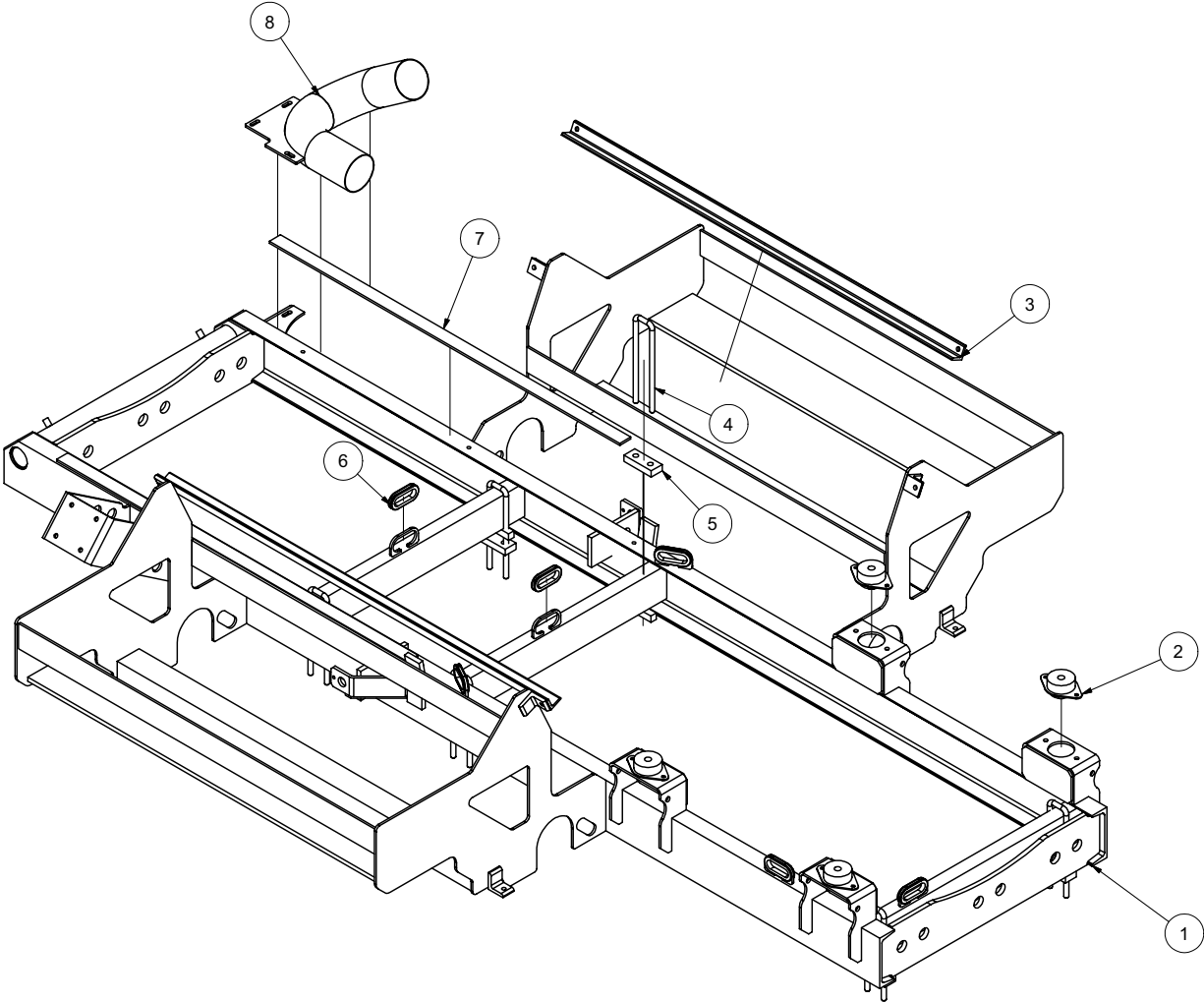



# Skid Assembly

# V500

ITEM	QTY	PART #	DESCRIPTION
1	1	8044742	TRAILER SKID V500 STD RF
2	4	8030904	ISOLATOR 840LB.
	4	U000560	SCREW, HC 3/8"-16 X 3"
	4	8030851	WASHER, SNUBBING
	4	U120110	NUT, LOCK 3/8"-16
	8	U000420	SCREW, HC 3/8"-16 X 1"
	24	U200060	WASHER, FLAT 3/8"
	8	U210060	WASHER, LOCK 3/8"
	8	U100060	NUT, HEX 3/8"-16
3	2	8044456	WATER TANK ANGLE 125GAL
4	4	8040038	U-BOLT, 1/2-20 X 10"LG - 1 3/4"GAP GR.8
	4	8040038-1	WASHER, 1/2"
	4	8040038-2	NUT, 1/2"-20
5	4	8040240	U-BOLT MOUNTING BLOCK
6	6	8042812	GROMMET 2"ID 3"OD 1/4"WOG TRAILER SLOT (MODEL)
7	2	8041376	PLASTIC STRIP 1/4" X 1/2" X 30"
	6	U030015	SCREW SOCKET FLAT HEAD 1/4-20 X 3/4"
8	1	8044451	EXHAUST ELBOW TANK PIVOT 4"

# HOSES

3"

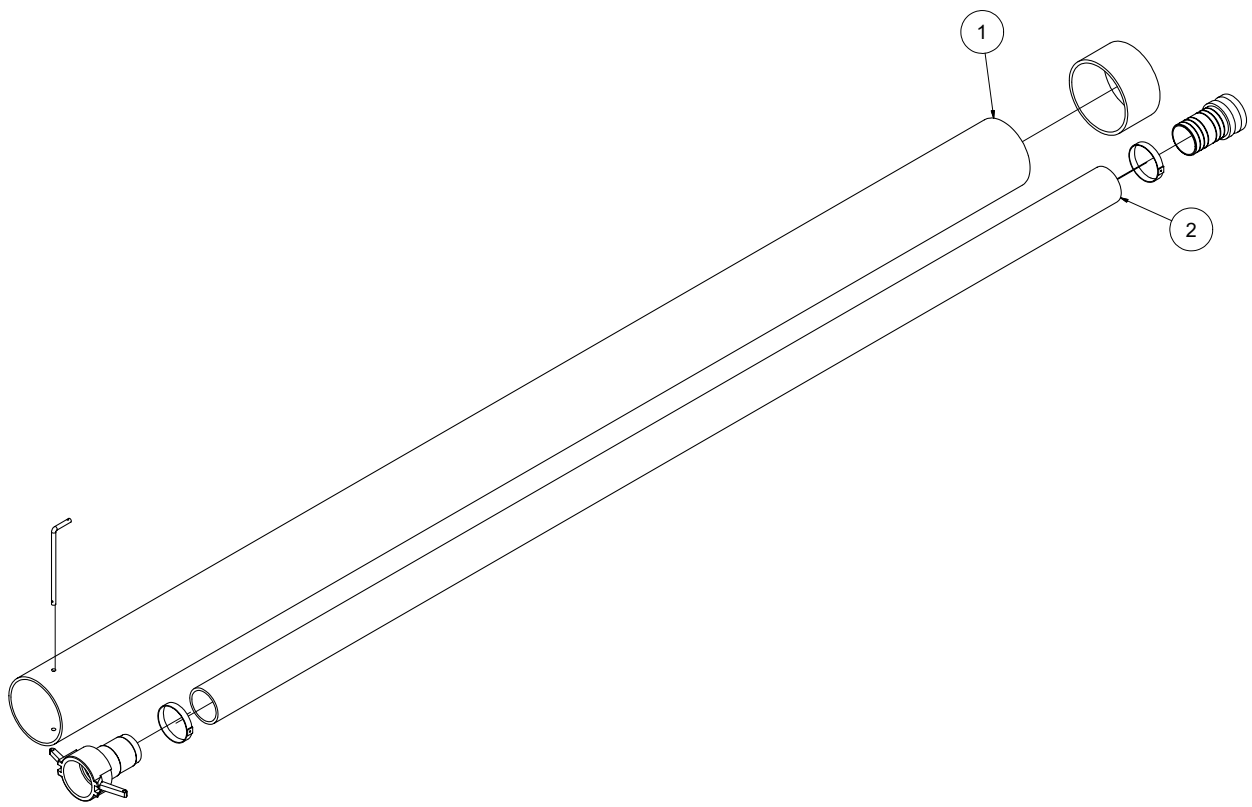

# HOSES

3''

ITEM	QTY	PART NO.	DESCRIPTION	
1	1	8041102	6" PVC STORAGE TUBE 10' LG	
	1	8030925	END CAP 6"	
	1	8041485	LANYARD CABLE	
	1	8043198	HOSE STORAGE CLAMP	
	2	U200060	WASHER. FLAT 3/8"	
	2	U100060	NUT, HEX 3/8"	
	1	8041101	HOSE STORAGE RETAINING ROD	
	1	R700170	R-CLIP, 1/2 - 5/8 SHANK	
	2	1	8040338	HOSE VAC KANAFLEX 3-110"
		1	8046441	CAMLOCK, 3" AL FCAM X M BARB
1		8046440	CAMCOCK, 3" AL MCAM X M BARB	
2		8030356	CLAMP, 4.5" PUNCHLOCK P18-S	

# Hydraulic Jack Option

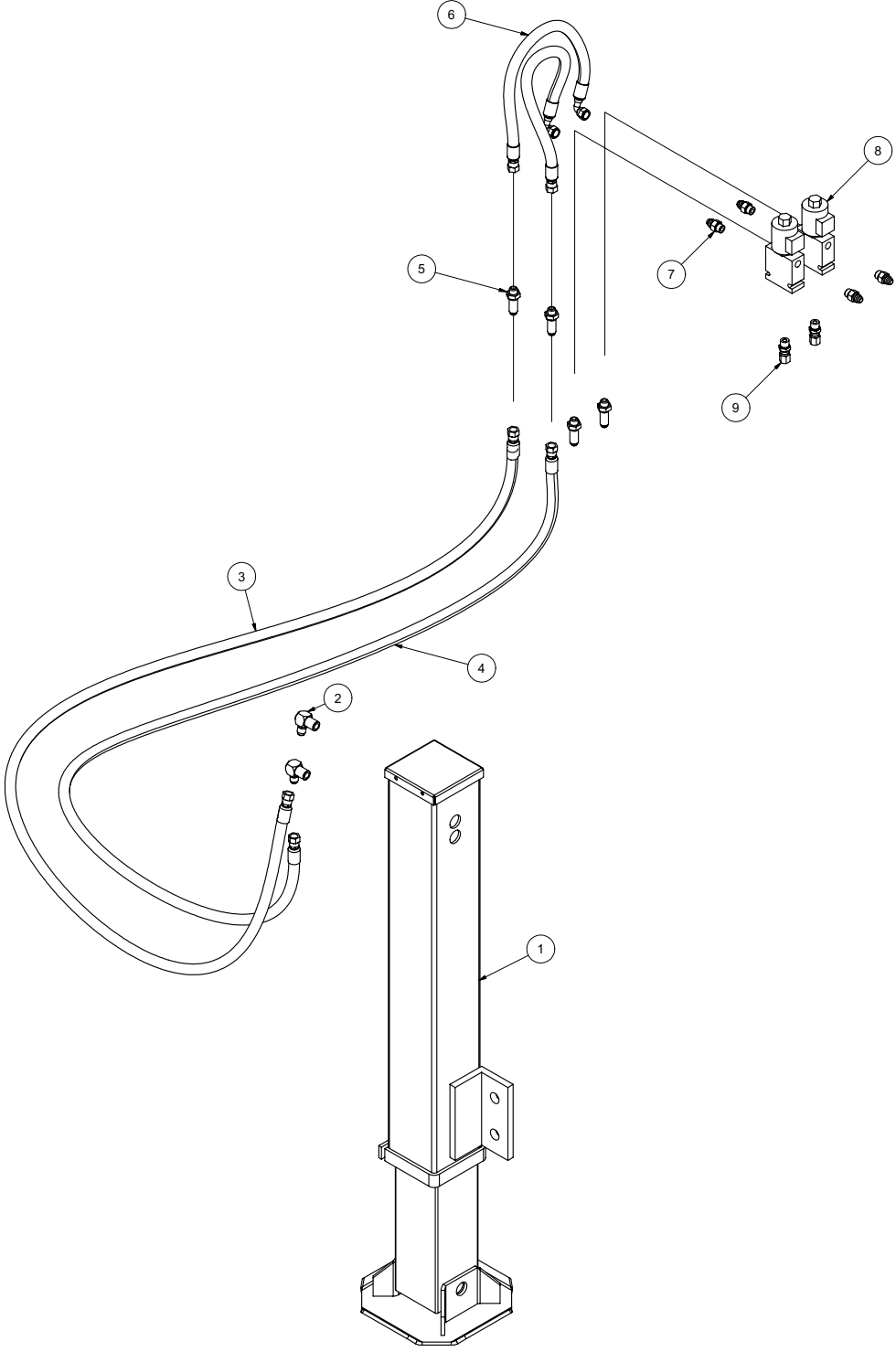

# Hydraulic Jack Option

ITEM	QTY	PART #	DESCRIPTION
1	1	8043653	HYDRAULIC JACK CYLINDER
2	2	T401103	ELBOW 90 DEG 3/8"MJ - 1/4"FJ
3	1	8042661	HOSE ASSY VAC 6-66 ST-90
4	1	8041442	HOSE ASSY VAC 6-60 ST-90
5	2	T400391	BULKHEAD, 3/8"MJ - 3/8"MJ
6	2	8040973	HOSE ASSY VAC 6-20 ST-90
7	4	T400037	UNION, 3/8"MB - 3/8"MJ
8	2	8041788	SOLENOID VALVE
9	2	8030512	UNION, 3/8"MB - 3/8"FJ
*	1	X000274	SWITCH ROCKER DPDT

\* NOT SHOWN

# Tool Rack Assembly

**STD**

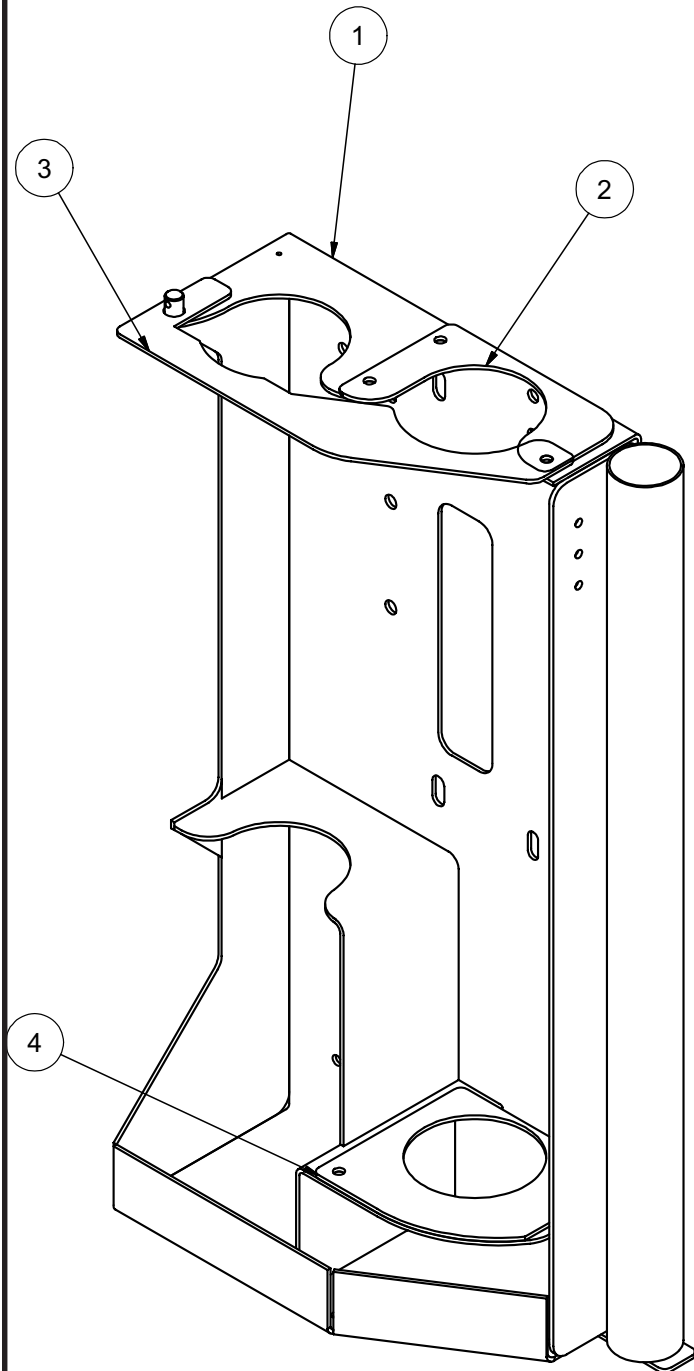

## I-BEAM TRAILER

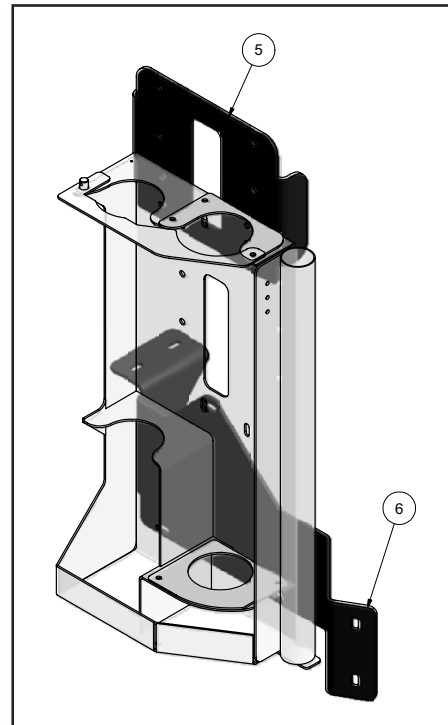

## SKID UNIT

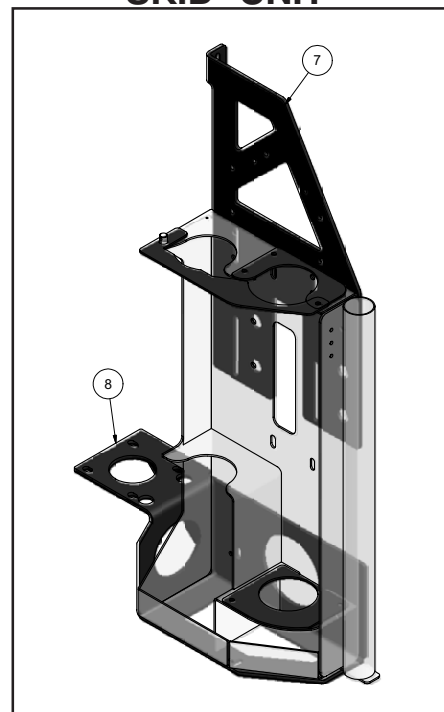

090909-E

**VACASSY757**

# Tool Rack Assembly

ITEM	QTY	PART NO.	DESCRIPTION
1	1	8040985	TOOL RACK WELDMENT
2	1	8045610	TOOL RACK 3" TOP INSERT
3	1	8040884	TOOL RACK CLOSURE
	1	R700175	R CLIP 7/8"
	1	8041259	STRAP, 10"
	1	8041485	LANYARD CABLE
	1	8041244	CLEVIS PIN 1/2" DIA. 3/4"
4	1	8045609	TOOL RACK BOTTOM INSERT
5	1	8044818	ANTIFREEZE BRACKET (I-BEAM TRAILER)
	4	U000020	SCREW, HC 5/16"-18 X 1.00"
	4	U000180	SCREW, HC 5/16"-18 X .750"
	16	U200040	WASHER, FLAT 5/16"
	8	U210041	NUT, LOCK NY 5/16"
6	1	8044817	TOOL RACK BRACKET (I-BEAM TRAILER)
	3	U000420	SCREW, HC .375"-16 X 1.00"
	3	U120110	NUT, LOCK .375"-16
	6	U200600	WASHER, FLAT .375"
7	1	8041780	ENCLOSURE STIFFENER BRACE (SKID UNITS)
	4	U000040	SCREW, HC 1/4"-20 X .750"
	8	U200020	WASHER, FLAT .250"
	4	U120100	NUT, LOCK .250"
8	1	8043601	TOOL RACK BRACKET (SKID UNITS)
	4	U000420	SCREW, HC .375"-16 X 1.00"
	8	U200060	WASHER, FLAT .375"
	4	U120110	NUT, LOCK .375-16
	2	U000040	SCREW, HC 1/4"-20 X .750"
	4	U200020	WASHER, FLAT .250"
	2	U120100	NUT, LOCK .250"

# Tools (Option)

# Reduction Tool STD

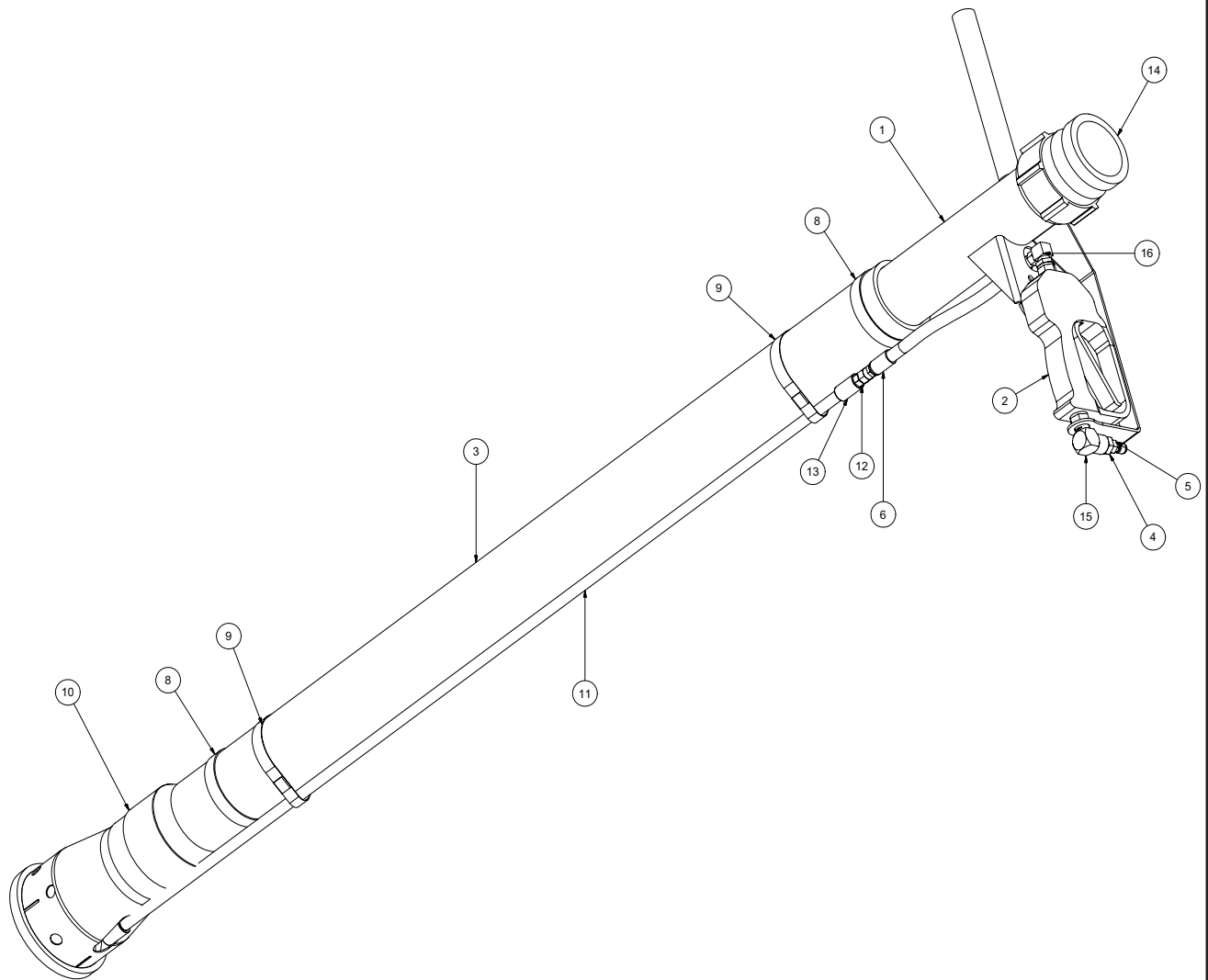



# Tools(Optional)

# Reduction Tool STD

ITEM	QTY	PART NO.	DESCRIPTION
-	-	8043115	TOOL VAC REDUCTION STD COMPLETE
1	1	8042862	TOOL VAC HEAD ASSY 3"
2	1	8042026	STRAIGHT SPRAY GUN
3	1	8042811	TOOL VAC REDUCTION PVC 3" X 48"
4	1	T400023	UNION 6MP 4FP
5	1	8030486	WATER QD 1/4 MNPT SS
6	2	T320030	FITTING, HOSE 4HO 4FJ
7	1	8031278	HOSE ASSEMBLY REDUCTION TOOL
8	2	8042605	CLAMP HOSE T BOLT 350
9	2	8042855	CLAMP HOSE T BOLT 375
10	1	8030627	TOOL VAC REDUCTION LOWER ASSY
11	1	8043764	VAC WATER SUPPLY TUBE CHROME 1/4NPT
12	1	T400020	UNION 1/4" MP-1/4" MJ STRAIGHT
13	2	T422010	COUPLING, PIPE 1/4"FP
14	1	8030391	BANJO 3" MALE 3" FNPT
15	1	T401065	ELBOW, 3/8 MP - 3/8 FP
16	1	T401100	ELBOW 4MP 4MJ 90
*	2	8030370	REDUCTION TOOL NOZZLE
*	2	8031268	REDUCTION TOOL NOZZLE 45 DEG

\* NOT SHOWN

# Tools

# Wash Wand

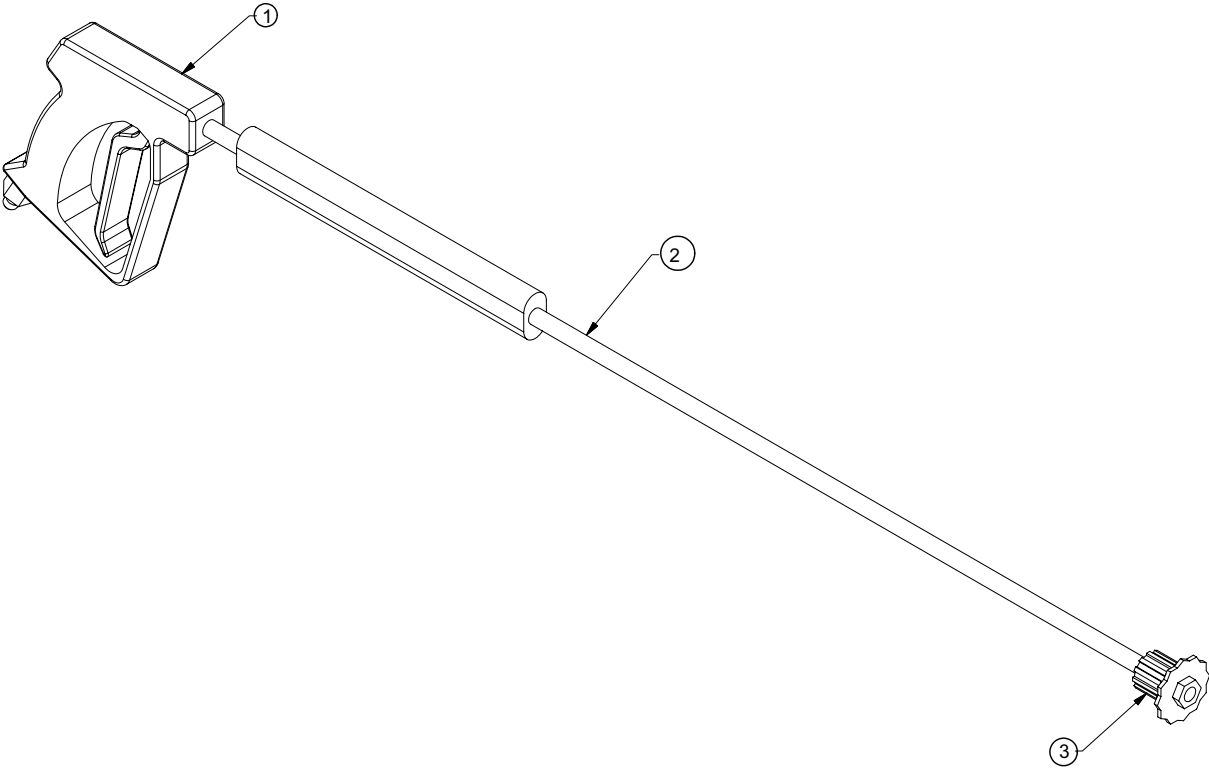

# Tools

# Wash Wand

<b>Item</b>	<b>Qty</b>	<b>Number</b>	<b>Description</b>
1	1	8030348	TOOL VAC SPRAY WAND COMPLETE
2	1	8030928	TRIGGERASSEMBLY
3	1	8030847	WAND
		8031308	NOZZLE,#6 40 DEGREE FOR WAND

# Tools

# 3" Suction Tool

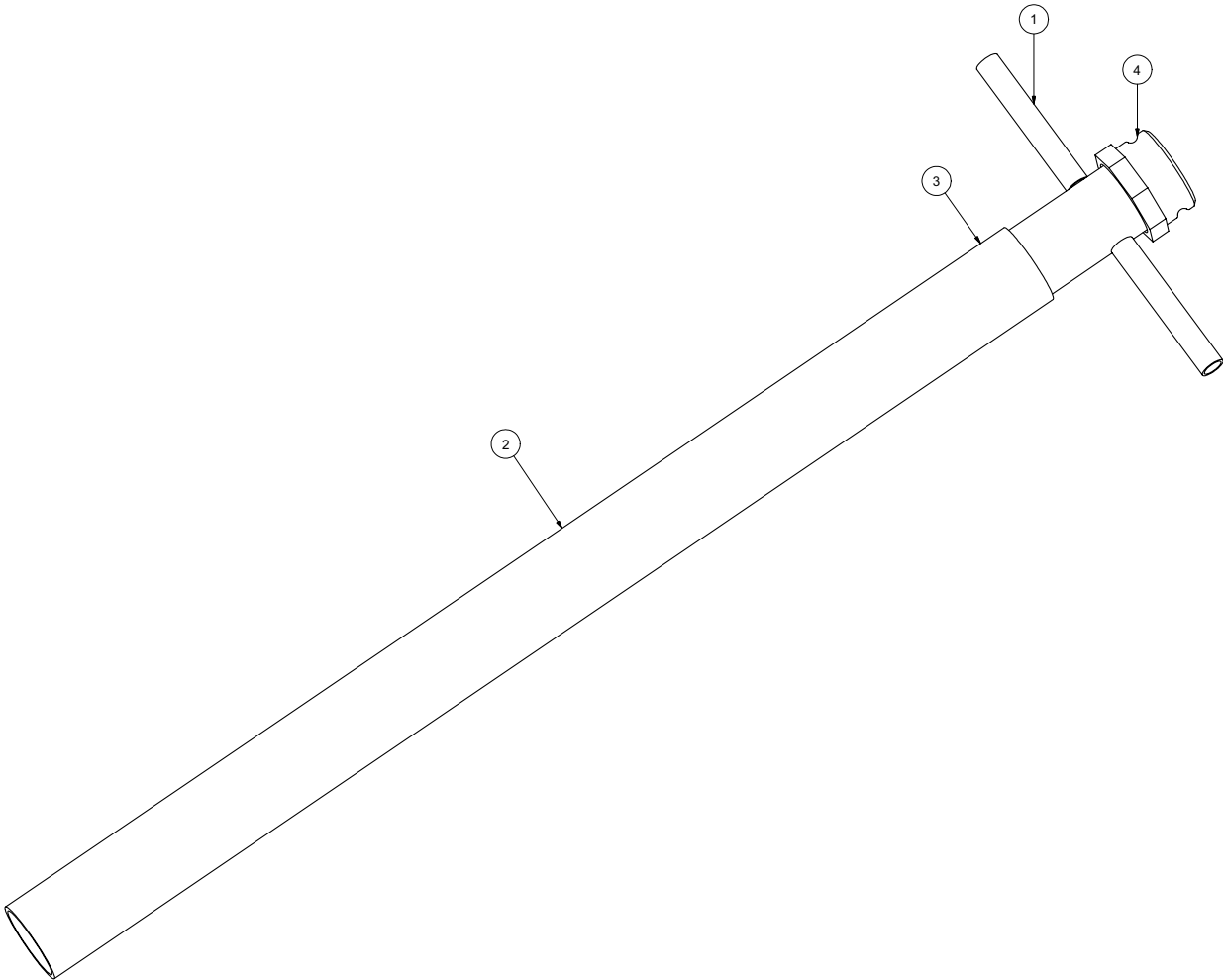

# Tools

# 3" Suction Tool

ITEM	QTY	NUMBER	DESCRIPTION
	1	8030215	TOOL VAC SUCTION 3" COMPLETE
1	1	8030317	TOOL VAC HANDLE ASSEMBLY 3"
2	1	8030313	PVC VACUUM TUBE 3"
3	1	8030356	CLAMP,4"PUNCHLOCK P16-S
4	1	8030391	COUPLING, 3" BANJO

# Tools

# Lawn Sweeper 3"

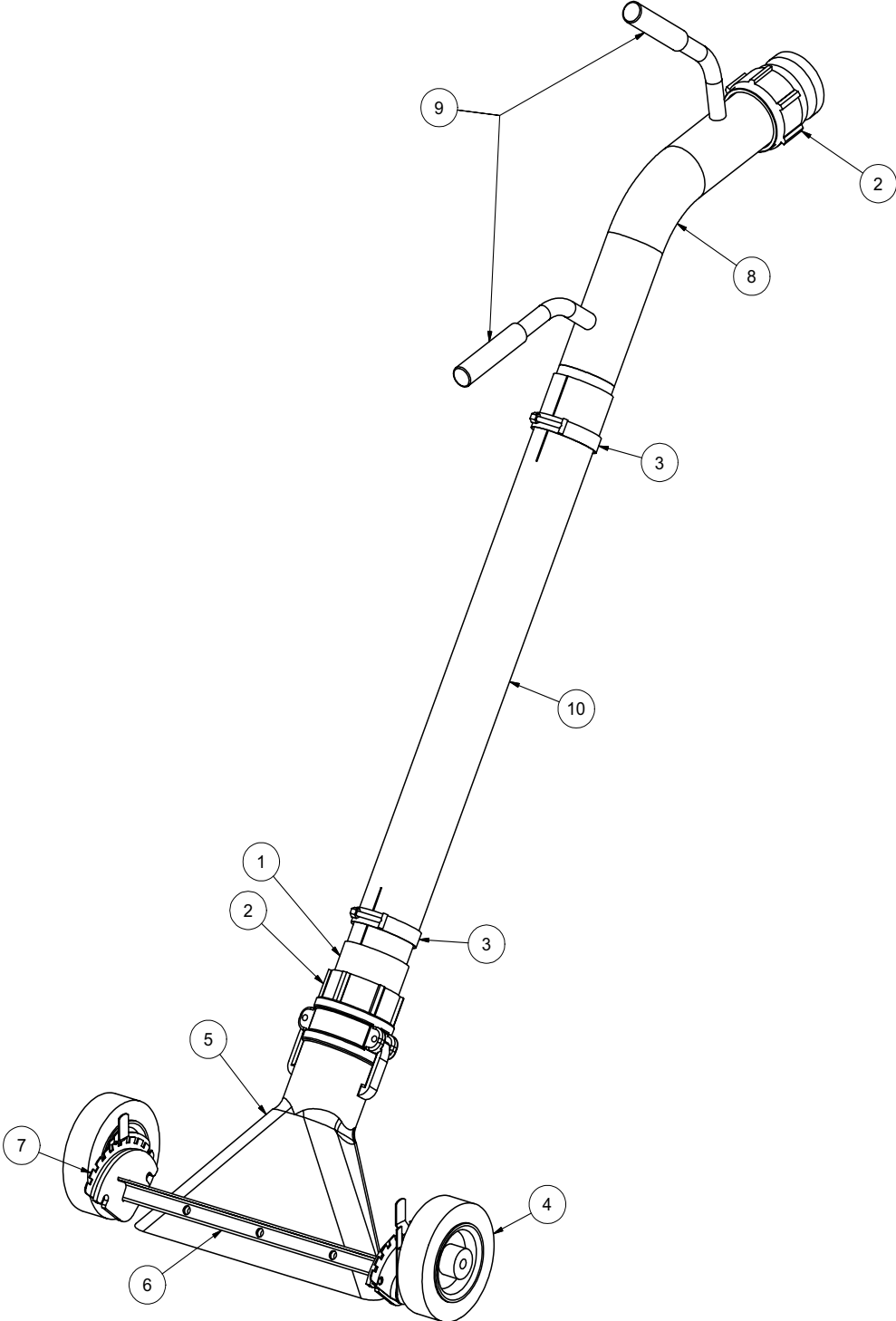

# Tools

# Lawn Sweeper 3''

ITEM	QTY	PART #	DESCRIPTION
1	1	8030287	3" HOSE X 3" MNPT ADAPTER
2	2	8030391	BANJO 3" MALE 3" FNPT
3	2	8042605	CLAMP T-BOLT 3" (350)
4	2	8043887	WHEEL 6" PNEUMATIC
5	1	8043925	DUCKBILL 3" ALUMINUM
6	1	8043928	LS WHEEL WELDMENT
7	1	8043931	WHEEL ADJUSTERS (1 LEFT/1 RIGHT)
8	1	8043933	LS HANDLE WELDMENT
9	2	J300080	HANDLE GRIP
10	1	8043932	PVC 3" X 30"

# Valve Box Cleanout Tool

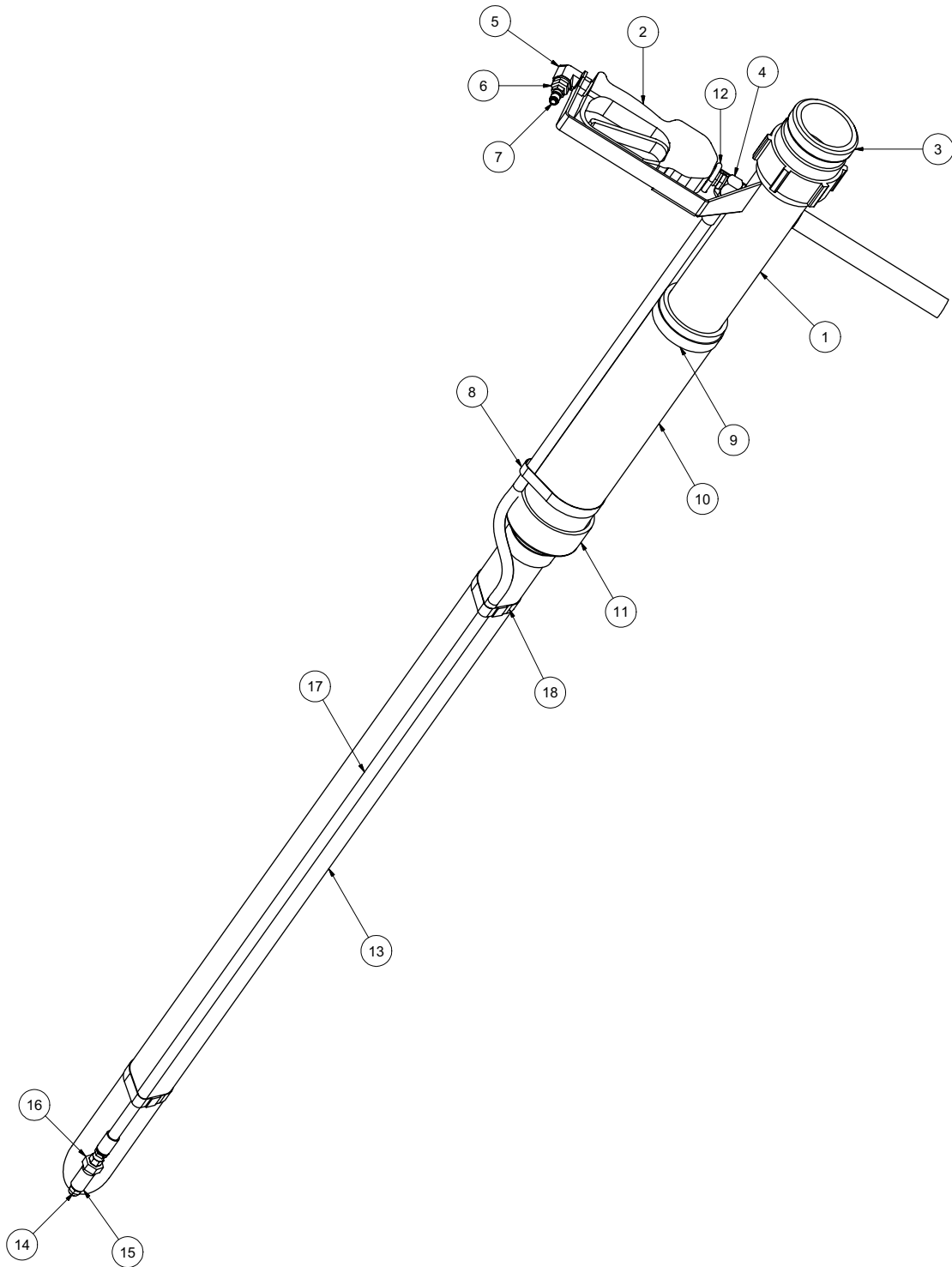

050709

VACASSY714



# Valve Box Cleanout Tool

ITEM	QTY	PART NO.	DESCRIPTION
1	1	8042862	REDUCTION TOOL HEAD WELD'T
2	1	8042026	STRAIGHT SPRAY GUN
3	1	8030391	BANJO 3" MALE FNPT
4	1	T401100	ELBOW 4MP 4MJ 90
5	1	T401065	ELBOW, 3/8 MP - 3/8 FP
6	1	T400023	REDUCER 6MP 4FP
7	1	8030486	WATER QD 1/4 MNPT SS
8	1	8042855	CLAMP HOSE T-BOLT 375
9	1	8042605	CLAMP HOSE T-BOLT 350
10	1	8044096	PVC 3" DIA X 9" LONG
11	1	8030669	REDUCER PVC 3" TO 2" SLIP ON
12	1	U010019	U-BOLT 1_4-20 X 3_4 WIDE X 2 1_4 LONG
13	1	8044097	PVC 2" DIA X 42.5" LG
14	1	8031246	NOZZLE, .100 X 0 DEG
15	1	T422010	COUPLING 1/4"FP
16	1	U400020	UNION, 1/4" MP - 1/4" MJ
17	1	8044098	HOSE ASSY VALVE BOX CLEANOUT TOOL
18	2	8045316	CLAMP, HOSE T-BOLT 275

# Surface Cleaner

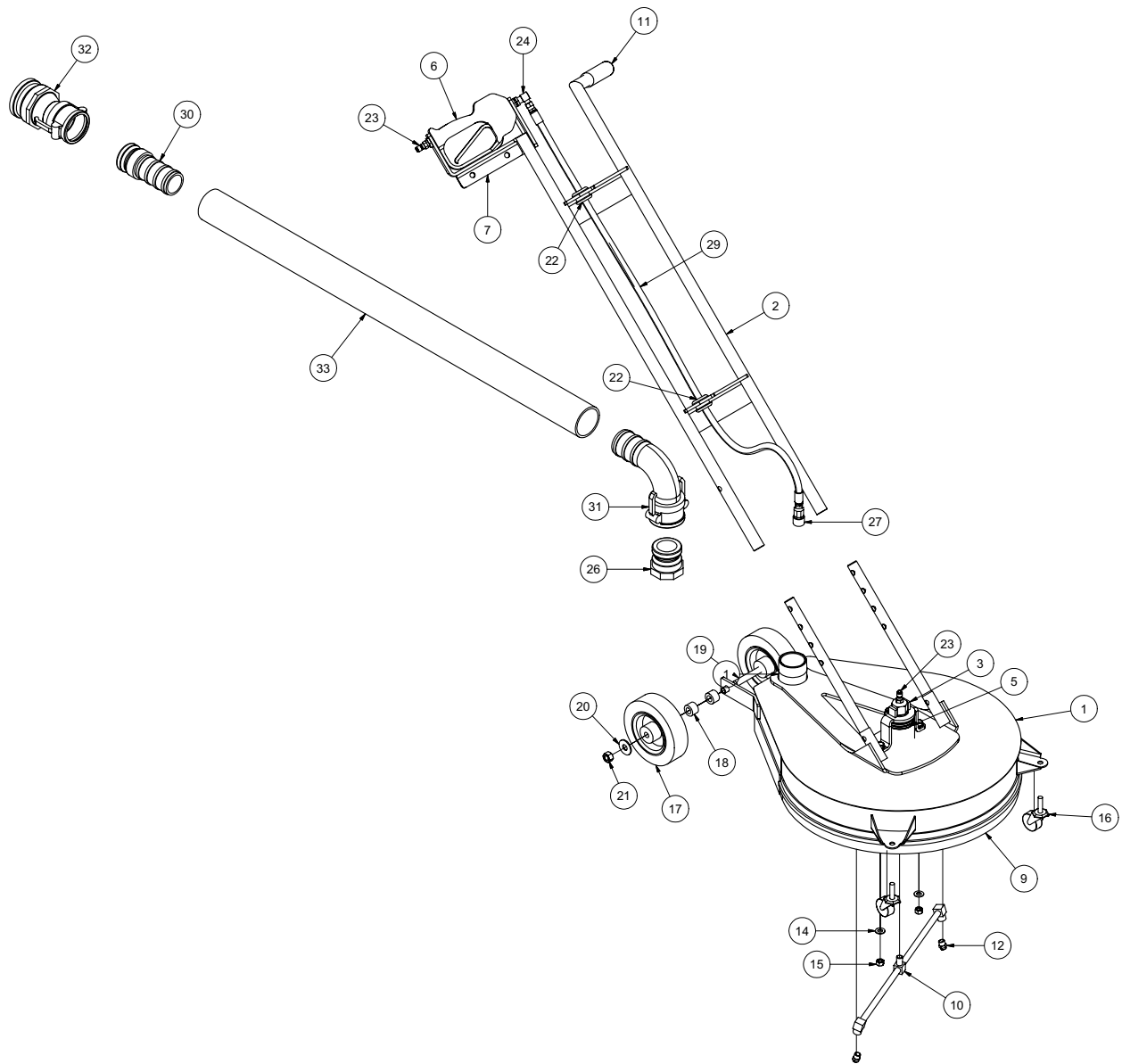

091710-E

VACASSY715

# Surface Cleaner

ITEM	QTY	PART NO.	DESCRIPTION
1	1	8041887	SURFACE CLEANER - HEAD ASSY
2	1	8042019	HANDLE ASSY
3	1	8041890	ROTARY RETAINER
4	2	8042022	HANDLE ADJ. TUBE
5	1	8042027	ROTARY HEAD
6	1	8042026	STRAIGHT SPRAY GUN
7	1	8042020	GUN CAPTURE BRACKET
8	1	8043467	SQUEEGEE
9	1	8042030	FLEXIBLE BRUSH
10	1	8042028	ROTARY ARM
11	1	J300080	GRIPHANDLE
12	2	8031419	NOZZLE, #4.0 25 DEG
13	2	U000420	SCREW, HC 3/8-16 X 1.00
14	4	U200600	WASHER, FLAT 3/8"
15	2	U100060	NUT, HEX 3/8-16
16	2	8043387	SWIVEL CASTER 1 5/8"
17	2	8043887	WHEEL 6" PNEUMATIC
18	2	8043591	SURFACE CLEANER REAR WHEEL SPACER
19	1	U001060	SCREW, HC 1/2-13 X 6.0
20	2	U200100	WASHER, FLAT 1/2"
21	1	U120120	NUT, LOCK 1/2-13
22	2	8041686	GROMMET 1"ID- 1 1/4"DOG-1/4"WO
23	2	8030486	WATER QD 1/4 MNPT SS
24	1	T401100	ELBOW 4MP 4MJ 90
25	1	T320030	FITTING, HOSE 4HO 4FJ
26	1	8043389	ADAPTER M2" F THREAD
27	1	8030526	FITTING, QD WATER 1/4"F-1/4"FP
28	1	T320300	FITTING, HOSE 4HO 4MP
29	1	8044108	HOSE VAC SURFACE CLEANER
30	1	8043392	ADAPTER M2" F THREAD
31	1	8043391	REDUCER COUPLER 2"F 90 DEG - 3"M
32	1	8043395	REDUCER COUPLER 2" X 3" ADAPTER
33	1	8043398	HOSE VAC CLEAR 2"
*	2	8043397	CLAMP VAC CLEAR HOSE 2"
*	4	U360020	PIN, U-LOCK 3/8 X 1.5

# Tools

# Rotary Lance

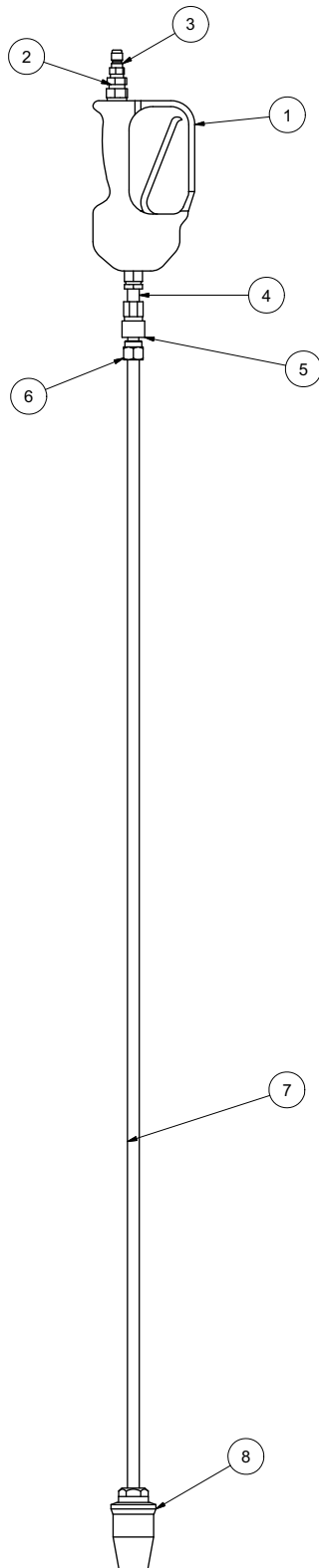

# Tools

# Rotary Lance

ITEM	QTY	PART NO.	DESCRIPTION
1	1	8042026	STRAIGHT SPRAY GUN
2	1	T400023	UNION 6MP-4FP
3	1	8030486	WATER QD 1/4MNPT SS
4	1	T421010	NIPPLE, CLOSE 1/4"
5	1	8030526	FITTING, QD WATER 1/4F - 1/4"FP
6	1	8030487	WATER QD 1/4 FNPT SS
7	1	8043764	47 INCH LANCE EXT. 1/4NPT X 1/4NPT
8	1	8042691	ROTARY WOBBLE NOZZLE .085

# Hot Box Assembly

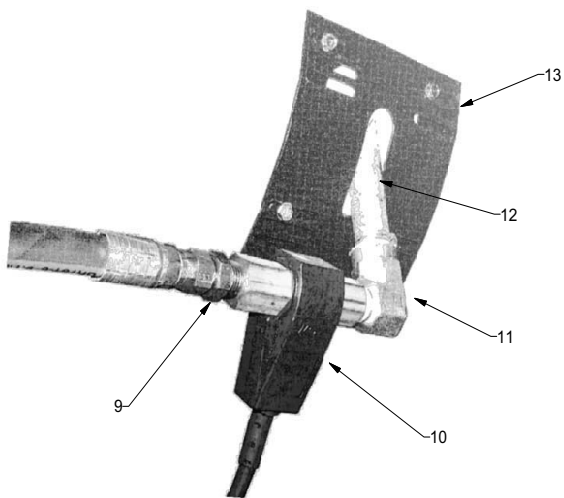
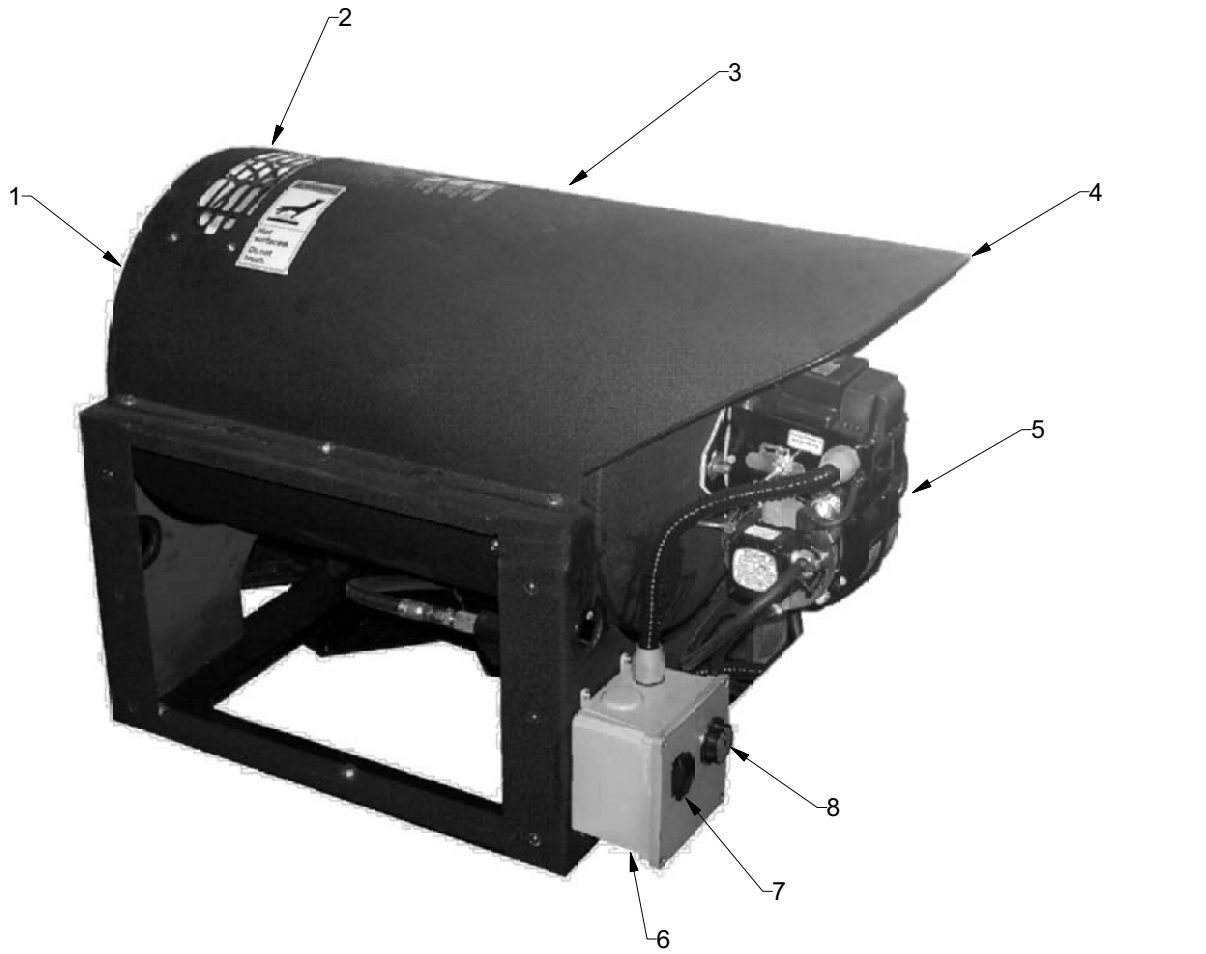

071808

VACASSY949

# Hot Box Assembly

ITEM	QTY	NUMBER	DESCRIPTION
1	1	8040088-23	INSULATION DISC
	1	8040088-21	COIL ASSEMBLY
	1	8040088-22	INSULATION BLANKET
	1	8040088-01	INSULATION DRUM HEAD
	1	8040088-20	BOTTOM WRAP ASSEMBLY
2	1	8040088-26	SLOTTED EXHAUST PLATE
	4	8040088-27	CLIP NUT 1/4-2 DUNC
	4	8040088-28	WASHER ZI SAE TYPE A 3/16
	4	8040088-29	SCREW #10-032 X 3/4 LONG
3	1	8040088-25	TOP WRAP
4	1	8040088-24	EDGING 3 FT REQUIRED
5	1	8040088-03	BURNER-12 VOLT
	1	8040088-02	NOZZLE-OIL
	1	8040088-04	LOCKNUT 1/2-ELECTRICAL
	1	8040088-05	CONDUIT STRAIGHT CONNECTOR
	1	8040088-09	ELBOW 1/4 M 1/4 BARB 90 BRASS
6	1	8040089-39	CONTROL BOX COMPLETE
	1	8040088-33	CONTROL BOX ONLY
	4	8040088-30	STRAIN RELIEF
	1	8040088-34	RELAY CONTROL
	1	X000143	PLUG, ENCLOSURE 3/4" KNOCKOUT
7	1	8040088-36	ROCKER SWITCH 15AMP 24 VOLT
8	1	8040088-17	ADJUSTABLE THERMOSTAT 86-194F
9	2	T400029	REDUCER 1/2 MP - 3/8 MJIC
10	1	8040088-14	FLOW SWITCH
11	1	8040088-13	ELBOW 1/2 F X 3/8 M STEEL
12	2	8040088-12	PIPE NIPPLE 1/2 NPT X 5 1/2 LONG
13	2	8040088-11	PATCH PLATE
	8	8040088-10	SCREW SELF DRILL #10 X 1/2
14	1	8040088-38	FUEL FILTER WITH ELEMENT
	1	8040088-37	FUEL FILTER ELEMENT
*	1	8040088-18	CROSS 1/2 NPT STL
*	1	8040088-19	PRESSURE RELIEF VALVE 4500 PSI

\* ITEM NOT SHOWN

# Arrow Board Option

ARROW BOARD & DUST COVER  
NOT DRAWN TO SCALE

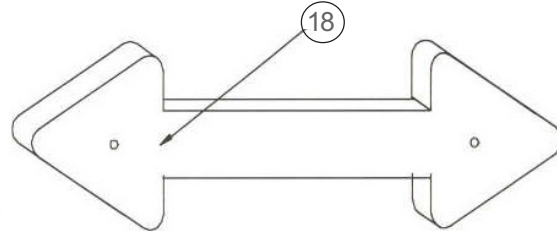
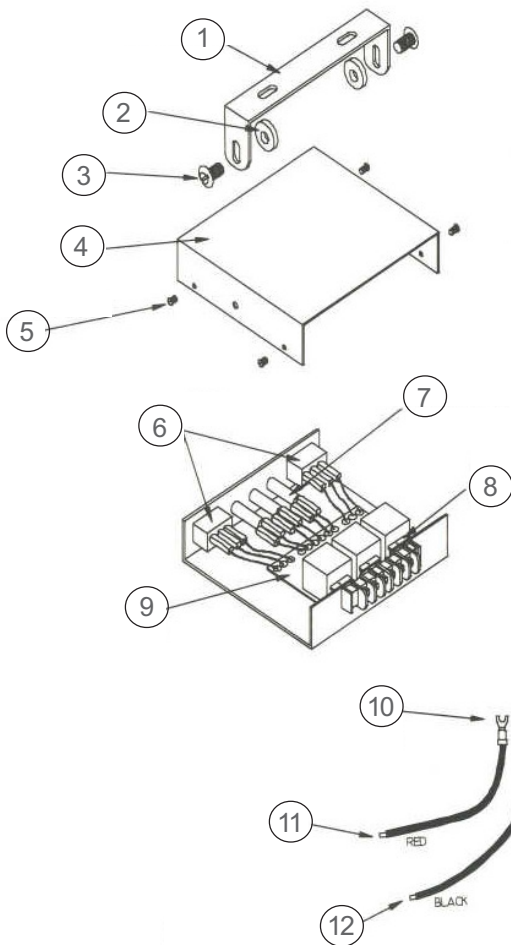

NOTE: MOUNTING BRACKETS MUST BE  
ATTACHED TO ARROW BOARD BEFORE  
DUST COVER IS REPLACED

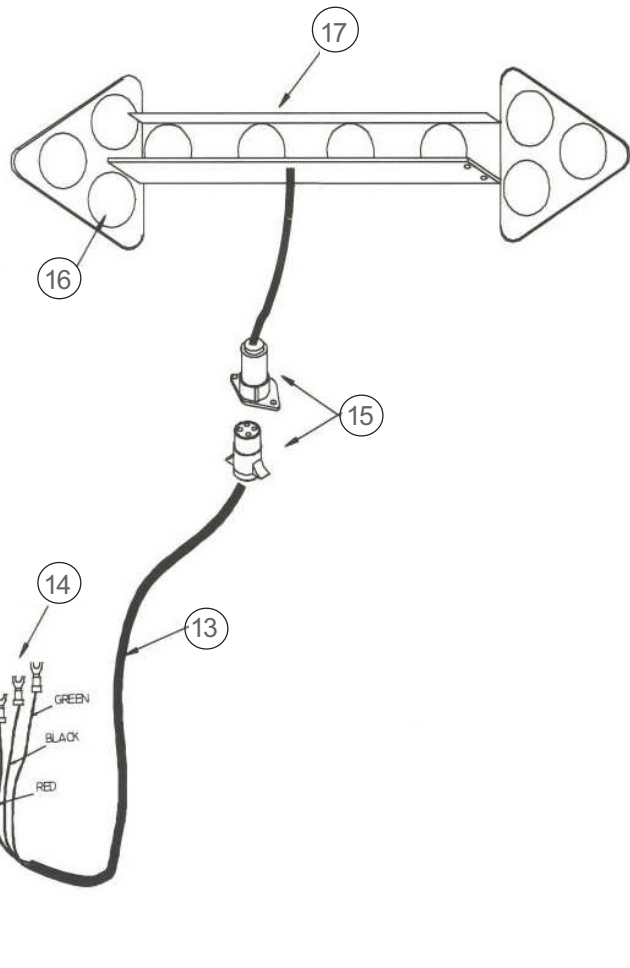



# Arrow Board Option

ITEM	QTY	PART #	DESCRIPTION
1	1	8042197-1	MOUNTING BAIL
2	2	8042197-2	WASHER
3	2	8042197-3	BOLT
4	1	8042197-4	COVER
5	4	8042197-5	MACHINE SCREW
6	2	8042197-6	SPDT SWITCH
7	3	8042197-7	RED PILOT LAMP
8	1	8042197-8	15 AMP FUSE
9	1	8042197-9	CIRCUIT BOARD ASSY
10	2	8042197-10	#6 BLUE SPADE CONNECTOR
11	4'	8042197-11	RED
12	4'	8042197-12	BLACK
13	20'	8042197-13	CABLE HARNESS
14	4	8042197-14	#6 BLUE SPADE CONNECTOR
15	1	8042197-15	4-WAY CONNECTOR
16	1	8042197-16	STANDARD LAMP ASSY
17	1	8042197-17	ARROWBOARD FRAME
18	1	8042197-18	DUST COVER
*	1	8045830	ARROWBOARD BRACKET
*	1	8046526	ARROWBOARD MOUNT PLATE

# Vacuum Diesel Engine Schematic

## VACUUM DIESEL ENGINE SCHEMATIC

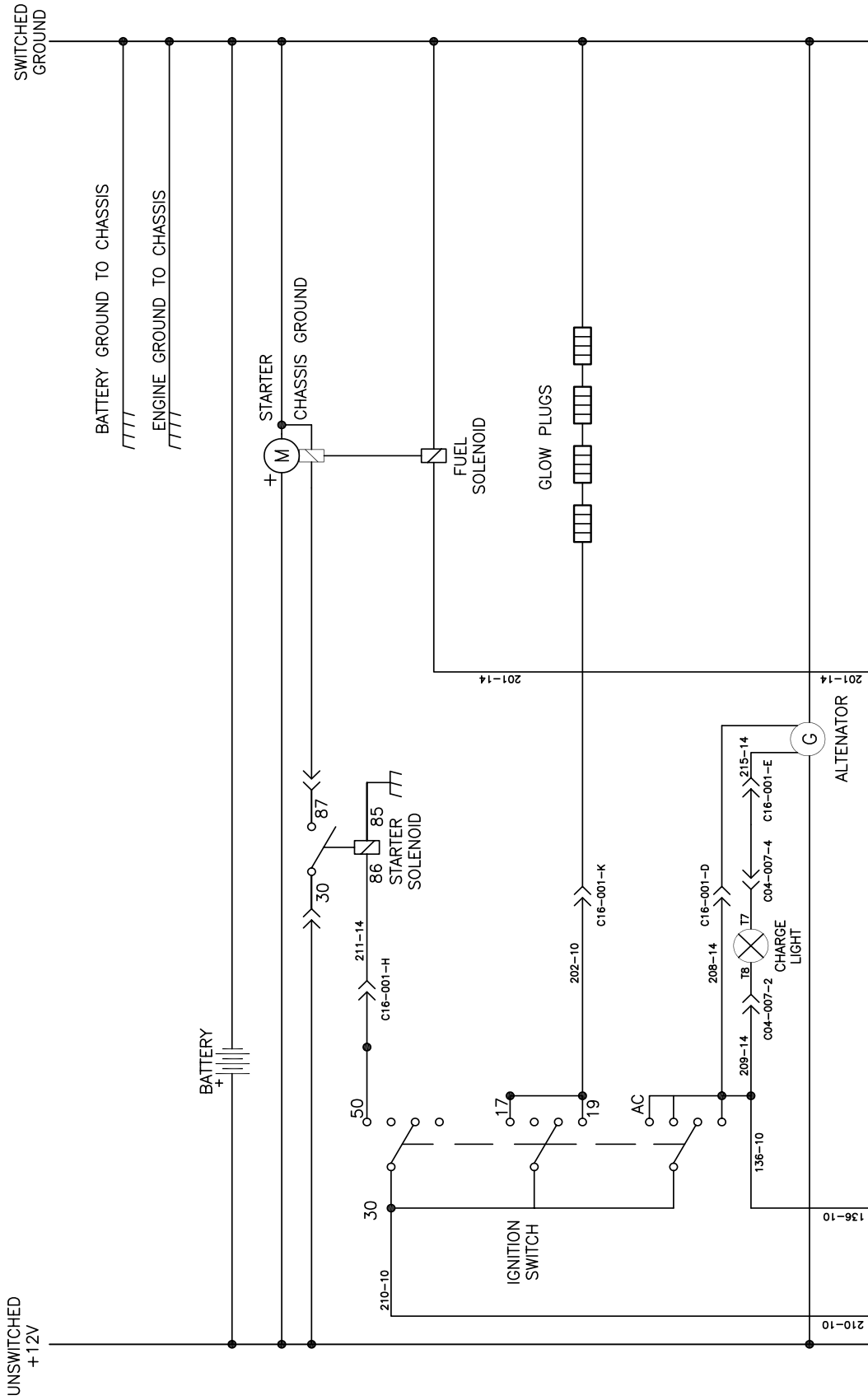

080108

UNSWITCHED  
+12V

SWITCHED  
GROUND

BATTERY GROUND TO CHASSIS

ENGINE GROUND TO CHASSIS

STARTER

CHASSIS GROUND

FUEL  
SOLENOID

GLOW PLUGS

BATTERY

IGNITION  
SWITCH

AC

CHARGE  
LIGHT

ALTERNATOR

# Vacuum Diesel Engine Schematic

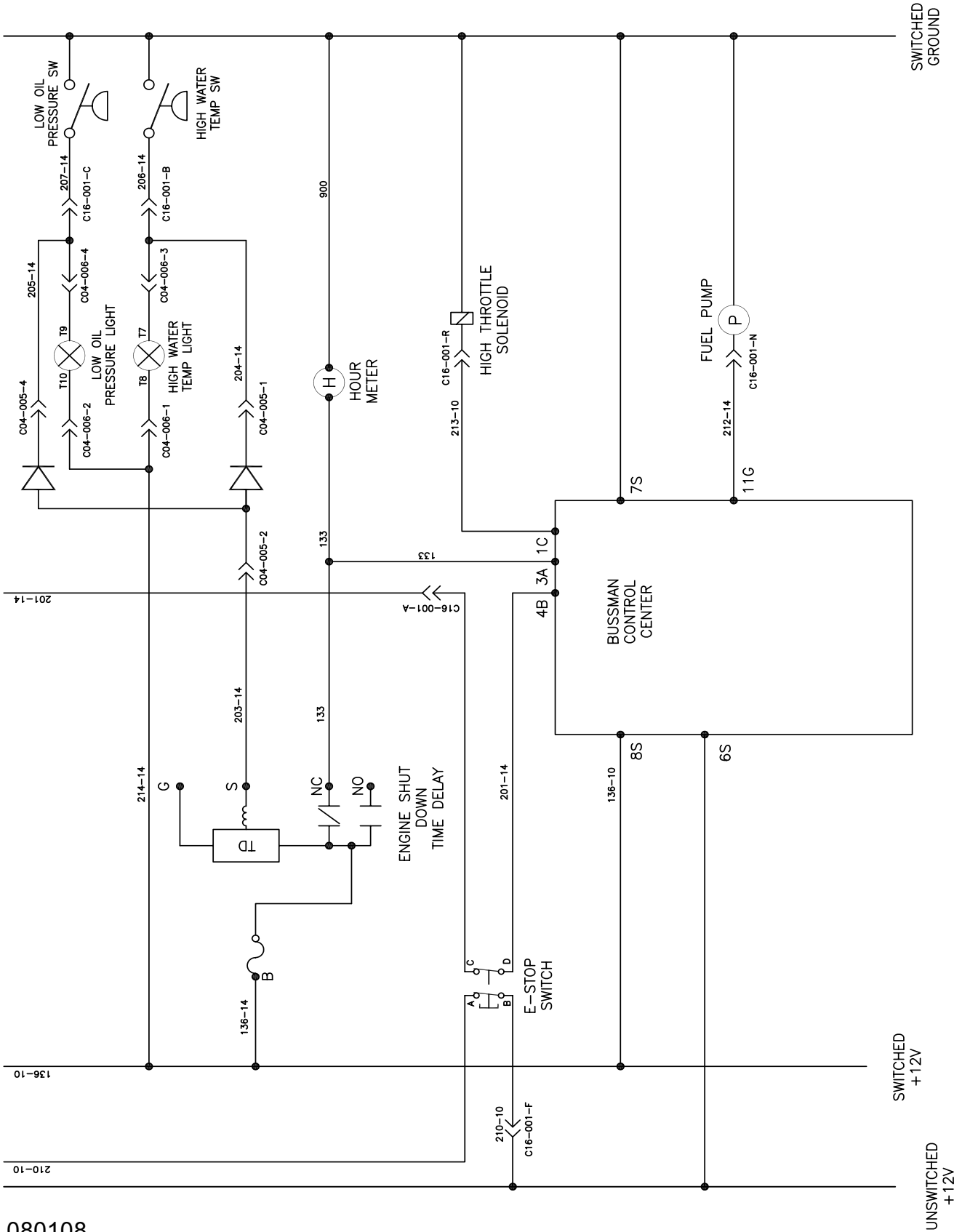

080108

# Vacuum Diesel Engine Schematic

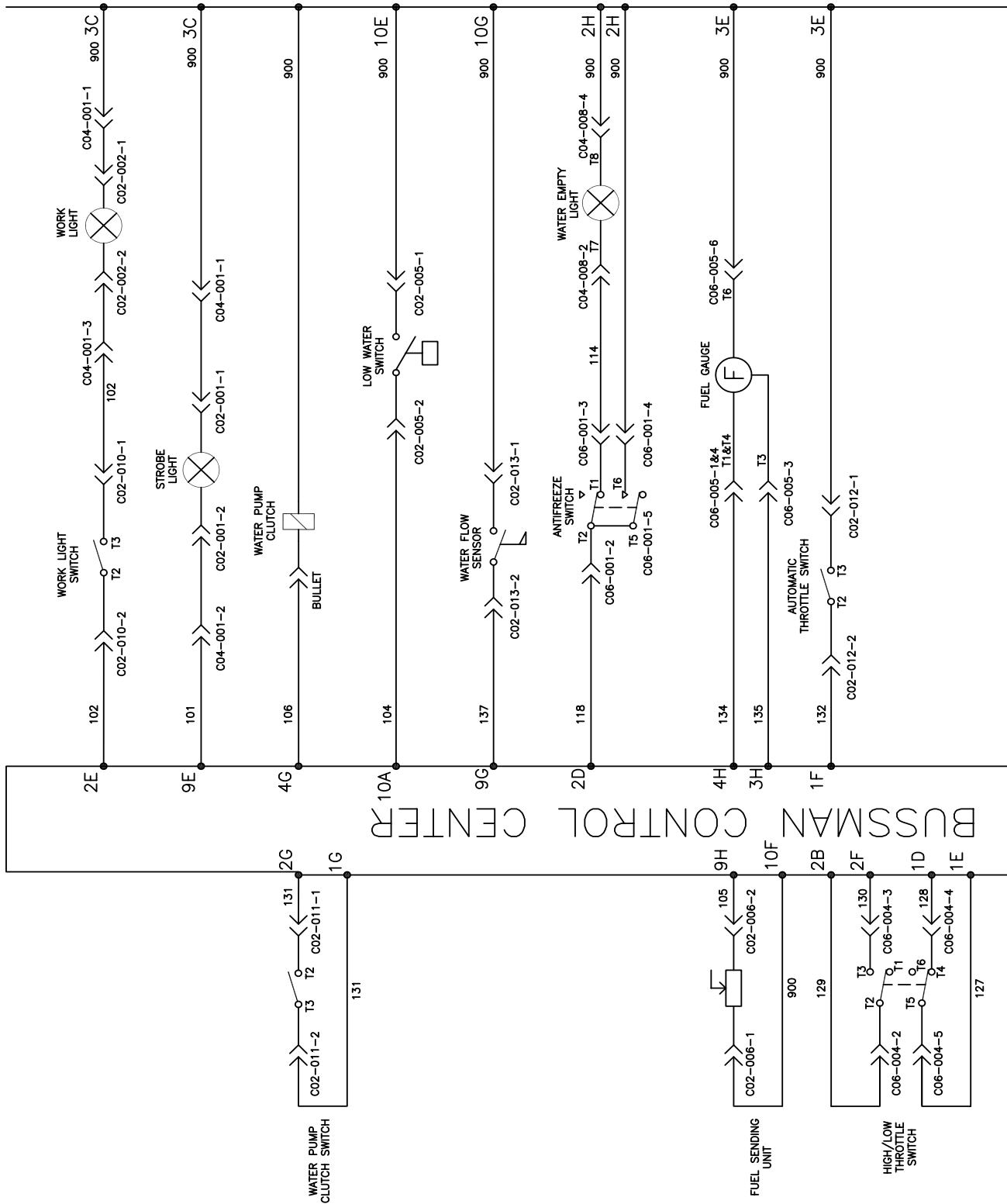

# Vacuum Diesel Engine Schematic

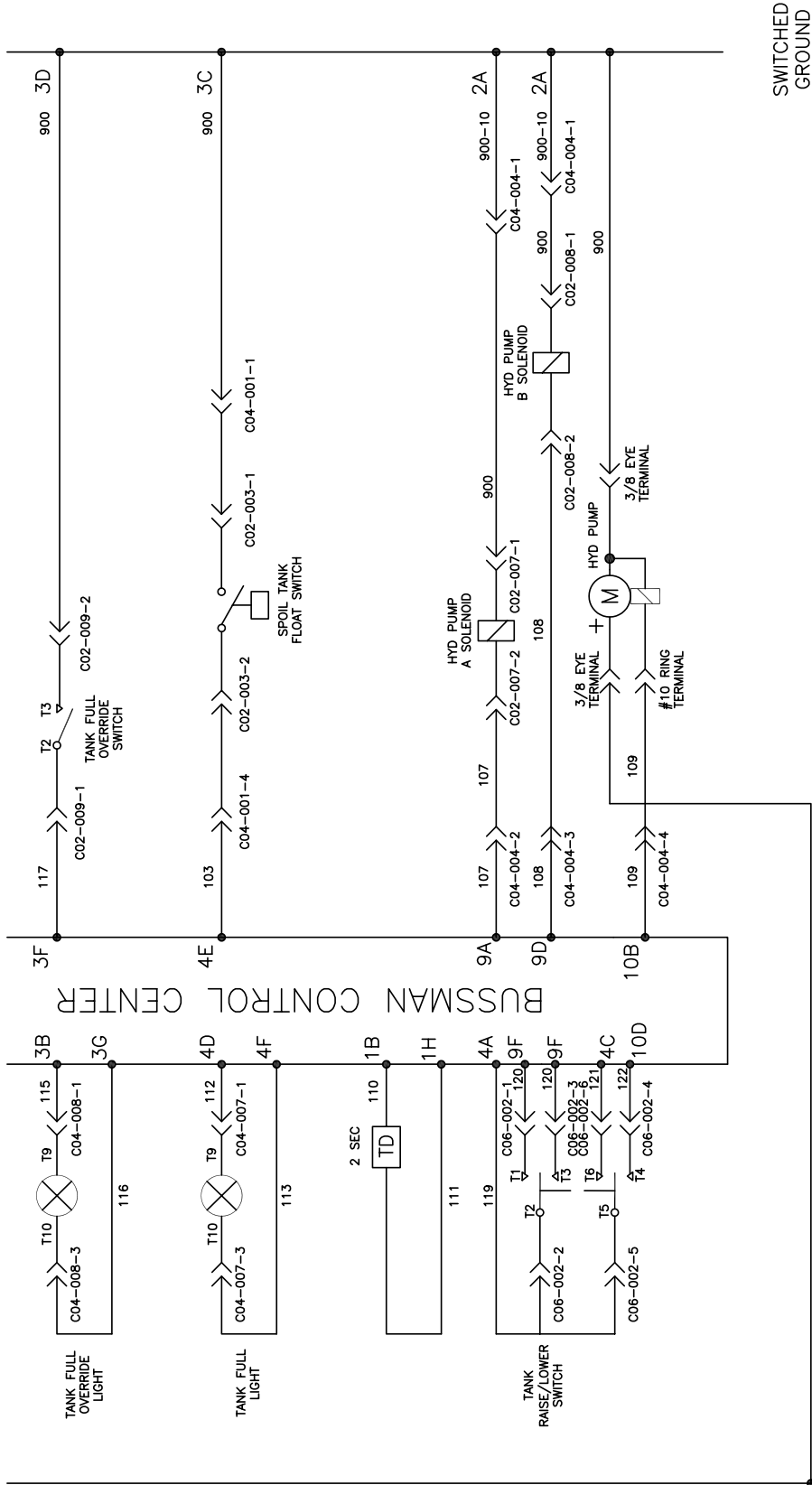

# Vacuum Diesel Engine Schematic

## BUSSMAN CONTROL CENTER OPTIONS

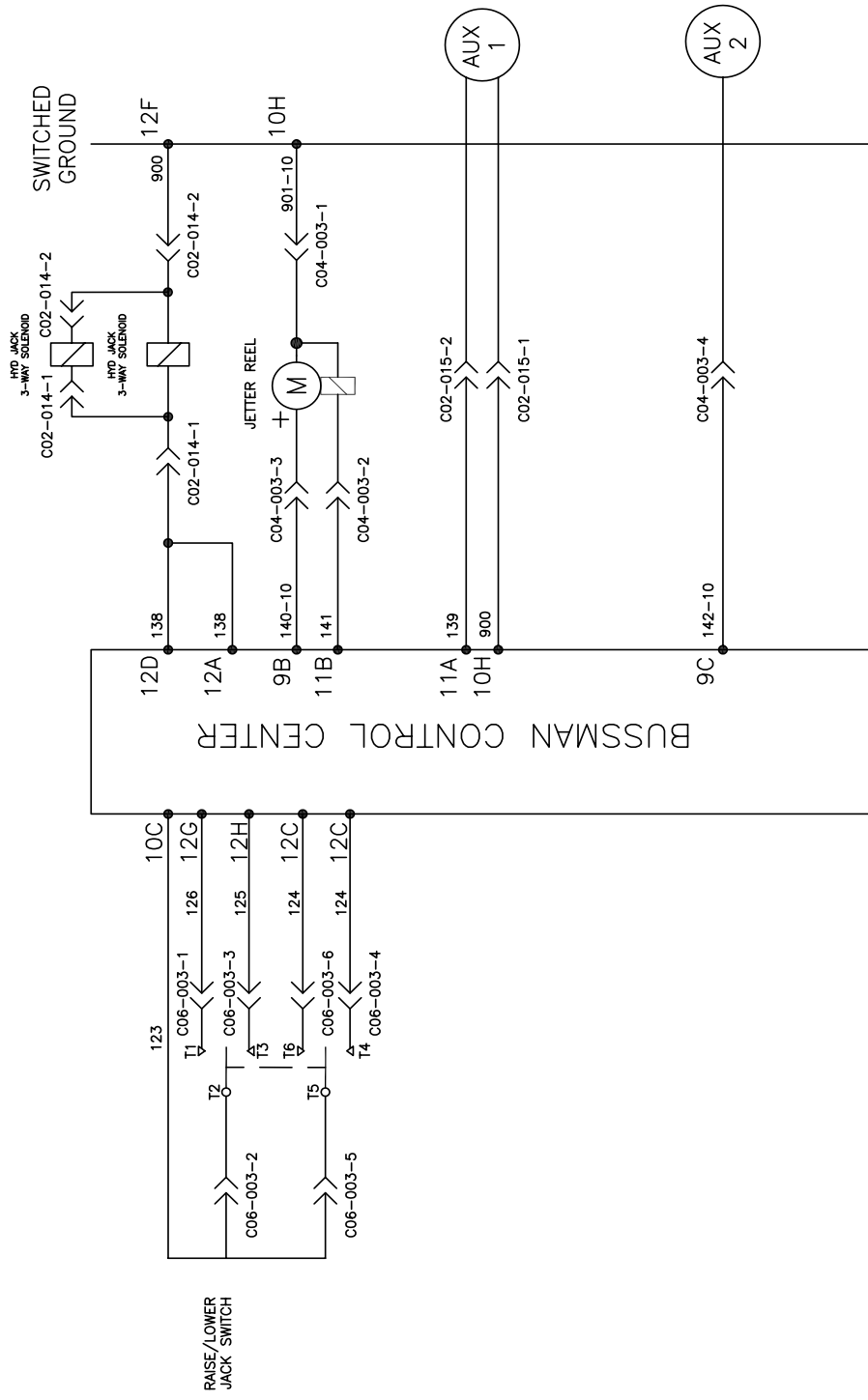

PAGE LEFT BLANK

# Hot Box Assembly

# WIRING SCHEMATIC

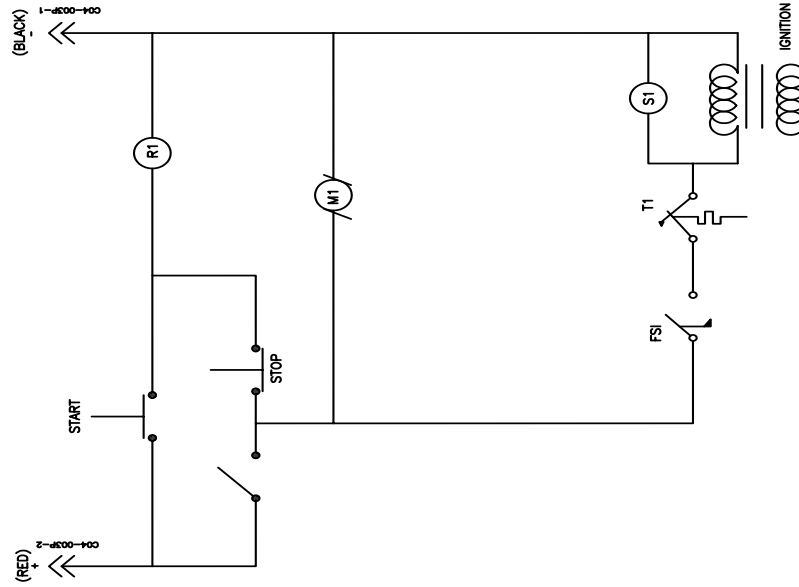

- R1-RELAY #1
- M1-BLOWER MOTOR
- FS-1-FLOW SWITCH
- T1-TEMP SWITCH
- S1-FUEL SOLENOID
- RTI-REMOTE THERMOSTAT CONTROL

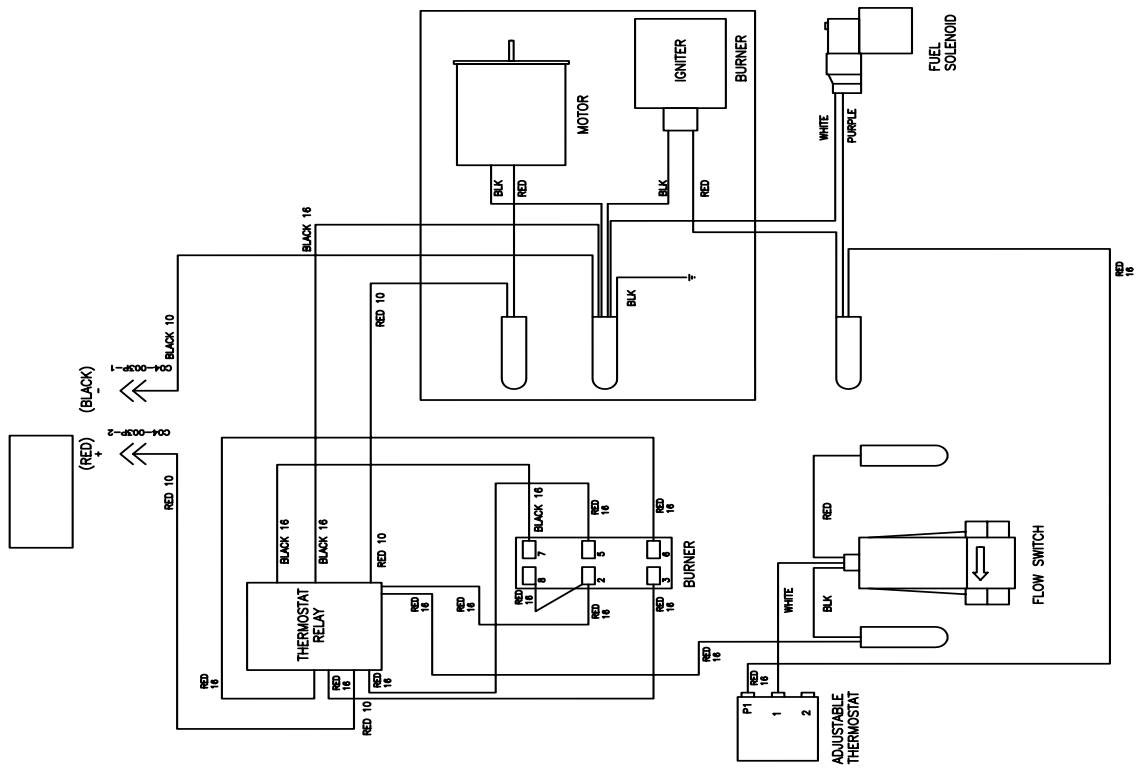

HOT BOX WIRING SCHEMATIC



**PAGE LEFT BLANK**

# Arrow Board Option

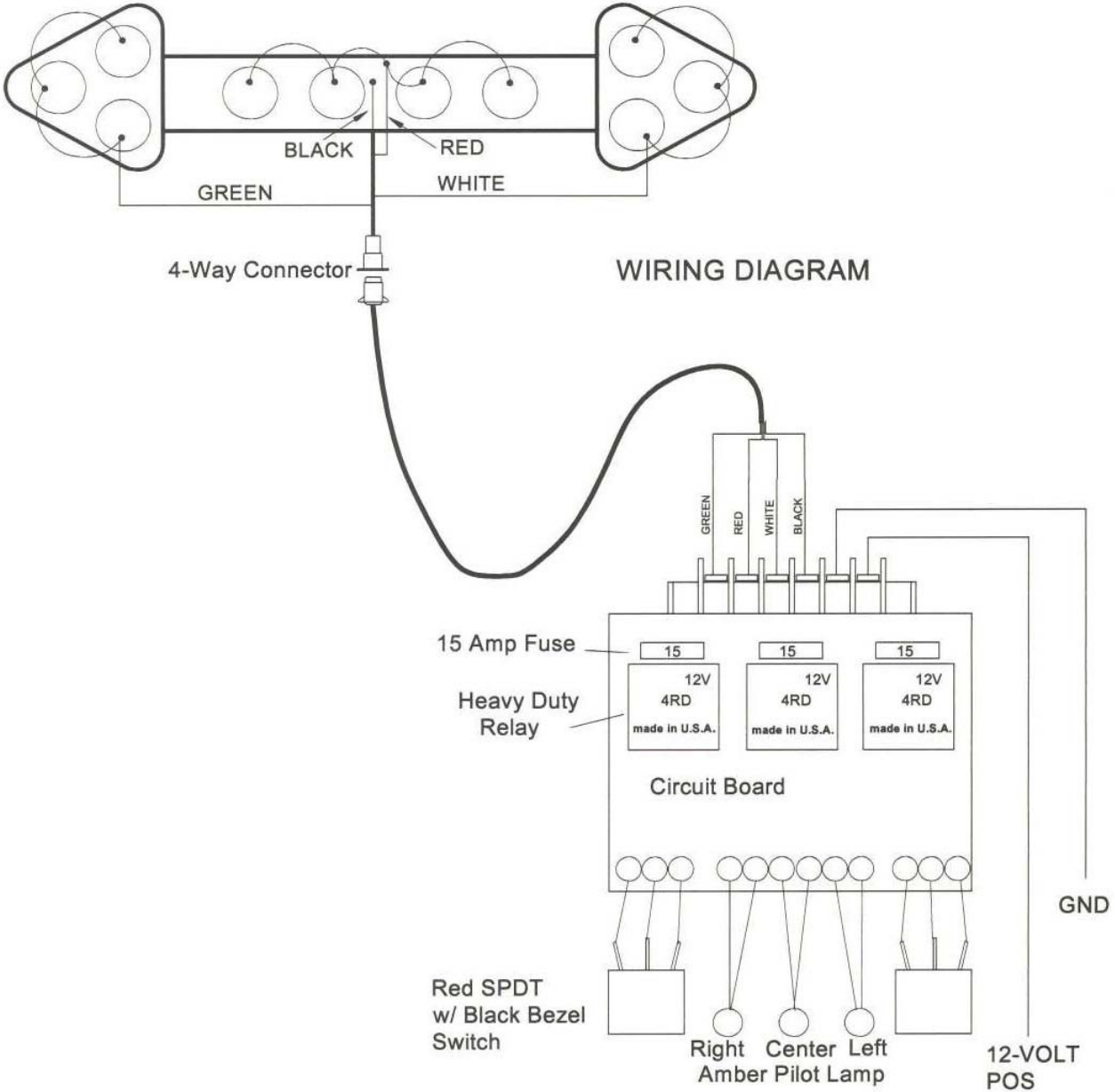

**PAGE LEFT BLANK**

# Tank and Optional Jack Hydraulic Schematic

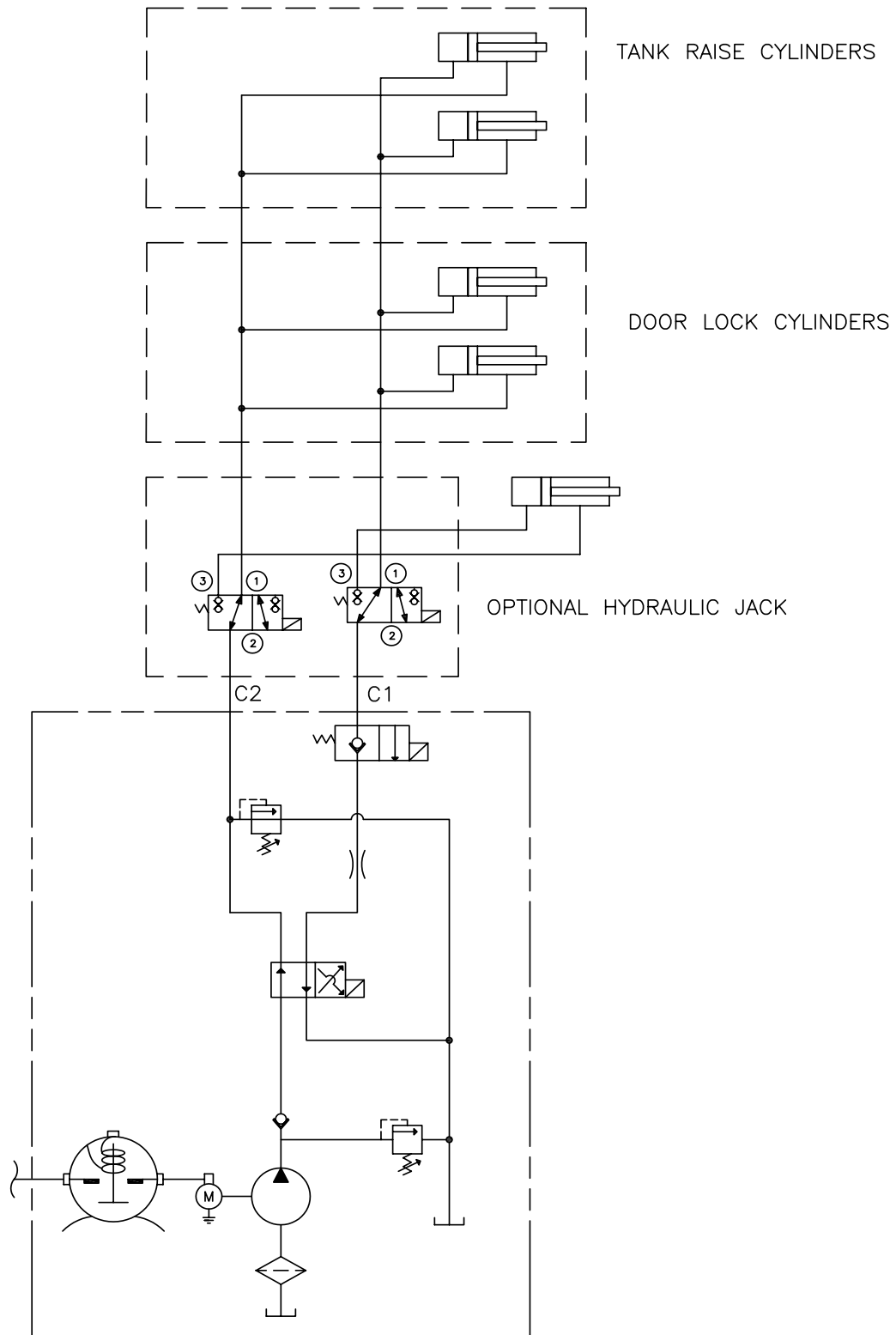

080108

12V DC HYDRAULIC PUMP

**PAGE LEFT BLANK**

# ROOTS

Blowers Compressors Exhausters

## Universal URAI-DSL

### Contents

---

Information Summary  
Safety Precautions  
Operating Limitations  
Lubrication  
Operatioin

Troubleshooting  
Inspection & Maintenance  
Data  
Assembly Drawings  
Parts List

### Do These Things To Get The Most From Your ROOTS™ blower

---

- **Make sure both driving and driven equipment is correctly lubricated before start-up. See LUBRICATION.**
- In event of trouble during installation or operation, do not attempt repairs of ROOTS furnished equipment. Notify ROOTS, giving all nameplate information plus an outline of operating conditions and a description of the trouble. Unauthorized attempts at equipment repair may void ROOTS warranty.
- Units out of warranty may be repaired or adjusted by the owner. Good inspection and maintenance practices should reduce the needs for repairs.

**NOTE:** Information in this manual is correct as of the date of publication. ROOTS reserves the right to make design or material changes without notice, and without obligation to make similar changes without notice, and without obligation to make similar changes on equipment of prior manufacture.

## Safety Precautions

It is important that all personnel observe safety precautions to minimize the chances of injury. Among many considerations, the following should be particularly noted:

- Blower casing and associated piping or accessories may become hot enough to cause major skin burns on contact.
- Internal and external rotating parts of the blower and driving equipment can produce serious physical injuries. Do not reach into any opening in the blower while it is operating, or while subject to accidental starting. Protect external moving parts with adequate guards.
- Disconnect power before doing any work, and avoid bypassing or rendering inoperative any safety or protective devices.
- If blower is operated with piping disconnected, place a strong coarse screen over the inlet and avoid standing in the discharge air stream. **CAUTION: Never cover the blower inlet with your hand or other part of body.**
- Stay clear of the blast from pressure relief valves and the suction area of vacuum relief valves.
- Use proper care and good procedures in handling, lifting, installing, operating and maintaining the equipment.
- Casing pressure must not exceed 25 PSI (1725 mbar) gauge. Do not pressurize vented cavities from an external source, nor restrict the vents without first consulting Roots.
- Do not use air blowers on explosive or hazardous gases.
- Other potential hazards to safety may also be associated with operation of this equipment. All personnel working in or passing through the area should be trained to exercise adequate general safety precautions.

## Operating Limitations

A ROOTS blower or exhauster must be operated within certain approved limiting conditions to enable continued satisfactory performance. Warranty is contingent on such operation.

Maximum limits for pressure, temperature and speed are specified in TABLE 1 for various models & sizes of blowers & exhausters. These limits apply to all units of normal construction, when operated under standard atmospheric conditions. Be sure to arrange connections or taps for instruments, thermometers and pressure or vacuum gauges at or near the inlet and discharge connections of the unit. These, along with a tachometer, will enable periodic checks of operating conditions.

**PRESSURE** – The pressure rise, between inlet and discharge, must not exceed the figure listed for the specific unit frame size concerned. Also, in any system where the unit inlet is at a positive pressure above atmosphere a maximum case rating of 25 PSI gauge (1725 mbar) should not be exceeded without first consulting Roots. Never should the maximum allowable differential pressure be exceeded.

On vacuum service, with the discharge to atmospheric pressure, the inlet suction or vacuum must not be greater than values listed for the specific frame size.

**TEMPERATURE** – Blower & exhauster frame sizes are approved only for installations where the following temperature limitations can be maintained in service:

- Measured temperature rise must not exceed listed values when the inlet is at ambient temperature. Ambient is considered as the general temperature of the space around the unit. This is not outdoor temperature unless the unit is installed outdoors.
- If inlet temperature is higher than ambient, the listed allowable temperature rise values must be reduced by 2/3 of the difference between the actual measured inlet temperature and the ambient temperature.
- The average of the inlet and discharge temperature must not exceed 250°F. (121°C).
- The ambient temperature of the space the blower/motor is installed in should not be higher than 120°F (48.8°C).

**SPEED** – These blowers & exhausters may be operated at speeds up to the maximum listed for the various frame sizes. They may be direct coupled to suitable constant speed drivers if pressure/temperature conditions are also within limits. At low speeds, excessive temperature rise may be a limiting factor.

**Special Note:** The listed maximum allowable temperature rise for any particular blower & exhauster may occur well before its maximum pressure or vacuum rating is reached. This may occur at high altitude, low vacuum or at very low speed. The units' operating limit is always determined by the maximum rating reached first. It can be any one of the three: Pressure, Temperature or Speed.

## Lubrication

---

### For Units with Splash Lubrication on Both Ends

Bearings and oil seals are lubricated by the action of the timing gears or oil slingers which dip into the main oil sumps

causing oil to splash directly on gears and into bearings and seals. A drain port is provided below each bearing to prevent an excessive amount of oil in the bearings. Seals located inboard of the bearings in each headplate effectively retain oil within the sumps. Any small leakage that may occur should the seals wear passes into a cavity in each vented headplate and is drained downward.

Oil sumps on each end of the blower are filled by removing top vent plugs, Item (25), and filling until oil reaches the middle of the oil level sight gauge when the unit is not operating, Item (45 or 53), DO NOT FILL PAST THE MIDDLE OF THE SIGHT GLASS.

Initial filling of the sumps should be accomplished with the blower not operating, in order to obtain the correct oil level. Approximate oil quantities required for blowers of the various models and configurations are listed in Table 3. Use a good grade of industrial type non-detergent, rust inhibiting, anti-foaming oil and of correct viscosity per Table 2. **\*ROOTS synthetic oil (Roots P/N 813-106-) is specified and recommended.** Roots does not recommend automotive type lubricants, as they are not formulated with the properties mentioned above.

The oil level may rise or fall on the gauge during operation, to an extent depending somewhat on oil temperature and blower speed.

Proper lubrication is usually the most important single consideration in obtaining maximum service life and satisfactory operation from the unit. Unless operating conditions are quite severe, a weekly check of oil level and necessary addition of lubricant should be sufficient. During the first week of operation, check the oil levels in the oil sumps about once a day, and watch for leaks. Replenish as necessary. Thereafter, an occasional check should be sufficient. It is recommended that the oil be changed after initial 100 hours of operation. Frequent oil changing is not necessary unless the blower is operated in a very dusty location.

Normal life expectancy of petroleum based oils is about 2000 hours with an oil temperature of about 180°F (82°C). As the oil temperature increases by increments of 15-18°F (8°C - 10°C), the life is reduced by half. Example: Oil temperatures of 210-216°F (99°C - 102°C) will produce life expectancy of 1/4 or 500 hours. Therefore, it is considered normal to have oil change periods of 500 hours with petroleum based oils.

Normal life expectancy of ROOTS™ Synthetic Oil is about 4000 to 8000 hours with an oil temperature of about 180°F (82°C). As the oil temperature increases by increments of 15-18°F (8°C - 10°C), the life is reduced by half. Example: Oil temperatures of 210-216°F (99°C - 102°C) will produce life expectancy of 1/4 or 1000 to 2000 hours.

NOTE: To estimate oil temperature, multiply the discharge temperature of the blower by 0.80. Example: if the discharge air temperature of the blower is 200° F, it is estimated that the oil temperature is 160° F.

\*ROOTS™ Synthetic Oil & Grease is superior in performance to petroleum based products. It has high oxidation stability, excellent corrosion protection, extremely high film strength and low coefficient of friction. Typical oil change intervals are increased 2-3 times over petroleum based lubricants. Also, ROOTS™ Synthetic Oil is 100% compatible with petroleum based oils. Simply drain the oil in the blower and refill the reservoirs with ROOTS™ Synthetic Oil to maintain optimum performance of your ROOTS™ blower.



## Operation

Before operating a blower under power for the first time, recheck the unit and the installation thoroughly to reduce the likelihood of avoidable troubles. Use the following procedure check list as a guide, but consider any other special conditions in the installation.

- Be certain that no bolts, tools, rags, or debris have been left in the blower air chamber or piping.
- If an outdoor intake without filter is used, be sure the opening is located so it cannot pick up dirt and is protected by a strong screen or grille. Use of the temporary protective screen as described under INSTALLATION is strongly recommended.
- Recheck blower leveling, drive alignment and tightness of all mounting bolts if installation is not recent. If belt drive is used, adjust belt tension correctly.
- Turn drive shaft by hand to make sure impellers still rotate without bumping or rubbing at any point.
- Ensure oil levels in the main oil sumps are correct.
- Check lubrication of driver. If it is an electric motor, be sure that power is available and that electrical overload devices are installed and workable.
- Open the manual unloading valve in the discharge air line. If a valve is in the inlet piping, be sure it is open.
- Bump blower a few revolutions with driver to check that direction of rotation agrees with arrow near blower shaft, and that both coast freely to a stop.

After the preceding points are cleared, blower is ready for trial operation under "no-load" conditions. The following procedure is suggested to cover this initial operation test period.

- a. Start blower, let it accelerate to full speed, then shut off. Listen for knocking sounds, both with power on and as speed slows down.
- b. After blower comes to a complete stop, repeat above, but let blower run 2 or 3 minutes. Check for noises, such as knocking sounds.
- c. After blower comes to a complete stop, operate blower for about 10 minutes unloaded. Check oil levels. Observe cylinder and headplate surfaces for development of hot spots such as burned paint, indicating impeller rubs. Be aware of any noticeable increase in vibration.

Assuming that all trials have been satisfactory, or that necessary corrections have been made, the blower should now have a final check run of at least one hour under normal operating conditions. After blower is restarted, gradually

close the discharge unloading valve to apply working pressure. At this point it is recommended that a pressure gauge or manometer be connected into the discharge line if not already provided, and that thermometers be in both inlet and discharge lines. Readings from these instruments will show whether pressure or temperature ratings of the blower are being exceeded.

During the final run, check operating conditions frequently and observe the oil levels at reasonable intervals. If excessive noise or local heating develops, shut down immediately and determine the cause. If either pressure rise or temperature rise across the blower exceeds the limit specified in this manual, shut down and investigate conditions in the piping system. Refer to the TROUBLESHOOTING CHECKLIST for suggestions on various problems that may appear.

The blower should now be ready for continuous duty operation at full load. During the first few days make periodic checks to determine whether all conditions remain steady, or at least acceptable. This may be particularly important if the blower is supplying air to a process system where conditions can vary. At the first opportunity, stop the blower and clean the temporary inlet protective screen. If no appreciable amount of debris has collected, the screen may be removed. See comments under INSTALLATION. At this same time, verify leveling, coupling alignment or belt tension, and mounting bolt tightness.

Should operating experience prove that blower capacity is a little too high for the actual air requirements, a small excess may be blown off continuously through the manual unloading or vent valve. Never rely on the pressure relief valve as an automatic vent. Such use may cause the discharge pressure to become excessive, and can also result in failure of the valve itself. If blower capacity appears to be too low, refer to the TROUBLESHOOTING CHECKLIST.

### Vibration Assessment Criteria

With measurements taken at the bearing locations on the housings, see chart below for an appropriate assessment guide for rotary lobe blowers rigidly mounted on stiff foundations.

In general, blower vibration levels should be monitored on a regular basis and the vibration trend observed for progressive or sudden change in level. If such a change occurs, the cause should be determined through spectral analysis.

As shown on the chart below, the level of all pass vibration will determine the need to measure discrete frequency vibration levels and the action required.

All Pass Vibration (in/sec)	Discrete Frequency Vibration (in/sec)	Action
0.45 or less	N/R	Acceptable
Greater than 0.45 but 1.0 or less	0.45 or less @ any frequency Greater than 0.45 @ any frequency	Acceptable Investigate
Greater than 1.0	Less than 1.0 Greater than 1.0	Investigate Investigate

## Troubleshooting Checklist

Trouble	Item	Possible Cause	Remedy
No flow	1	Speed too low	Check by tachometer and compare with published performance
	2	Wrong rotation	Compare actual rotation with Figure 1 Change driver if wrong
	3	Obstruction in piping	Check piping, valves, silencer to assure open flow path
Low capacity	4	Speed too low	See item 1, If belt drive, check for slippage and readjust tension
	5	Excessive pressure rise	Check inlet vacuum and discharge pressure and compare with Published performance
	6	Obstruction in piping	See item 3
	7	Excessive slip	Check inside of casing for worn or eroded surfaces causing excessive clearances
Excessive power	8	Speed too high	Check speed and compare with published performance
	9	Excessive pressure rise	See Item 5
	10	Impeller rubbing	Inspect outside of cylinder for high temperature areas, then check for impeller contact at these points. Correct blower mounting, drive alignment
	11	Scale, sludge, rust or product build up	Clean blower appropriately
Damage to bearings or gears	12	Inadequate lubrication	Check oil sump levels in gear and drive end headplates
	13	Excessive lubrication	Check oil levels. If correct, drain and refill with clean oil of recommended grade
	14	Excessive pressure rise	See Item 5
	15	Coupling misalignment	Check carefully. Realign if questionable
	16	Excessive belt tension	Readjust for correct tension
Vibration	17	Misalignment	See Item 15
	18	Impellers rubbing	See Item 10
	19	Worn bearings/gears	Check gear backlash and condition of bearings, and replace as indicated
	20	Unbalanced or rubbing impeller	Scale or process material may build up on casing and impellers, or inside impellers. Remove build-up to restore original clearances and impeller balance
	21	Driver or blower loose	Tighten mounting bolts securely
	22	Piping resonances	Determine whether standing wave pressure pulsations are present in the piping
	23	Scale/sludge build-ups	Clean out interior of impeller lobes to restore dynamic balance
Driver stops, or will not start	24	Casing strain	Re-work piping alignment to remove excess strain
	25	Impeller stuck	Check for excessive hot spot on headplate or cylinder. See item 10. Look for defective shaft bearing and/or gear teeth
	26	Scale, sludge, rust or product build-up	Clean blower appropriately
Excessive breather	27	Broken seal	Replace seals
Blow-by or excessive oil leakage to vent area	28	Defective O-ring	Replace seals and O-ring
Excessive oil leakage in vent area	29	Defective/plugged breather	Replace breather and monitor oil leakage
	30	Oil level too high	Check sump levels in gear and drive headplates.
	31	Oil type or viscosity incorrect	Check oil to insure it meets recommendations. Drain then fill with clean oil of recommended grade.
	32	Blower running hot	Check blower operating conditions to ensure they are within the operating limitations defined in this manual.

## Inspection & Maintenance: Universal RAI® series blowers

A good program of consistent inspection and maintenance is the most reliable method of minimizing repairs to a blower. A simple record of services and dates will help keep this work on a regular schedule. Basic service needs are:

- Lubrication
- Checking for hot spots
- Checking for increases or changes in vibration and noise
- Recording of operating pressures and temperatures

Above all, a blower must be operated within its specified rating limits, to obtain satisfactory service life.

A newly installed blower should be checked often during the first month of full-time operation. Attention there after may be less frequent assuming satisfactory performance. Lubrication is normally the most important consideration and weekly checks of lubricant levels in the gearbox and bearing reservoirs should be customary. Complete oil change schedules are discussed under **LUBRICATION**.

Driver lubrication practices should be in accordance with the manufacturer's instructions. If direct connected to the blower through a lubricated type coupling, the coupling should be checked and greased each time blower oil is changed. This will help reduce wear and prevent unnecessary vibration. In a belted drive system, check belt tension periodically and inspect for frayed or cracked belts.

In a new, and properly installed, unit there is no contact between the two impellers, or between the impellers and cylinder or headplates. Wear is confined to the bearings (which support and locate the shafts) the oil seals, and the timing gears. All are lubricated and wear should be minimal if clean oil of the correct grade is always used. Seals are subject to deterioration as well as wear, and may require replacement at varying periods.

Shaft bearings are designed for optimum life under average conditions with proper lubrication and are critical to the service life of the blower. Gradual bearing wear may allow a shaft position to change slightly, until rubbing develops between impeller and casing. This will cause spot heating, which can be detected by observing these surfaces. Sudden bearing failure is usually more serious. Since the shaft and impeller are no longer supported and properly located, extensive general damage to the blower casing and gears is likely to occur.

Oil seals should be considered expendable items, to be replaced whenever drainage from the headplate vent cavity becomes excessive or when the blower is disassembled for

any reason. Some oil seal leakage may occur since an oil film under the lip is required for proper operation. Periodically leaked oil should be wiped off from surfaces. Minor seal leakage should not be considered as indicating seal replacement.

Timing gear wear, when correct lubrication is maintained, should be negligible. Gear teeth are cut to provide the correct amount of backlash, and gears correctly mounted on the shafts will accommodate a normal amount of tooth wear without permitting contact between lobes of the two impellers. However, too high an oil level will cause churning and excessive heating. This is indicated by unusually high temperature at the bottom of the gear housing. Consequent heating of the gears will result in loss of tooth-clearance, backlash and rapid wear of the gear teeth usually will develop. Continuation of this tooth wear will eventually produce impeller contacts (knocking), and from this point serious damage will be unavoidable if blower operation is continued. A similar situation can be produced suddenly by gear tooth fracture, which is usually brought on by sustained overloading or momentary shock loads.

Problems may also develop from causes other than internal parts failure. Operating clearances within a blower are only a few thousandths of an inch. This makes it possible for impeller interference or casing rubs to result from shifts in the blower mounting, or from changes in piping support. If this type of trouble is experienced, and the blower is found to be clean, try removing mounting strains. Loosen blower mounting bolts and reset the leveling and drive alignment. Then tighten mounting again, and make sure that all piping meets blower connections accurately and squarely. Foreign materials in the blower will also cause trouble, which can only be cured by disconnecting the piping and thoroughly cleaning the blower interior.

A wide range of causes & solutions for operating troubles are covered in the **TROUBLE SHOOTING CHECKLIST**. The remedies suggested should be performed by qualified mechanics with a good background. Major repairs generally are to be considered beyond the scope of maintenance, and should be referred to an authorized Roots distributor.

Warranty failures should not be repaired at all, unless specific approval has been obtained through Roots before starting work. Unauthorized disassembly within the warranty period may void the warranty.

Figure 2 - Allowable Overhung Loads for V-Belt Drives Universal RAI®/URAI®-DSL Units

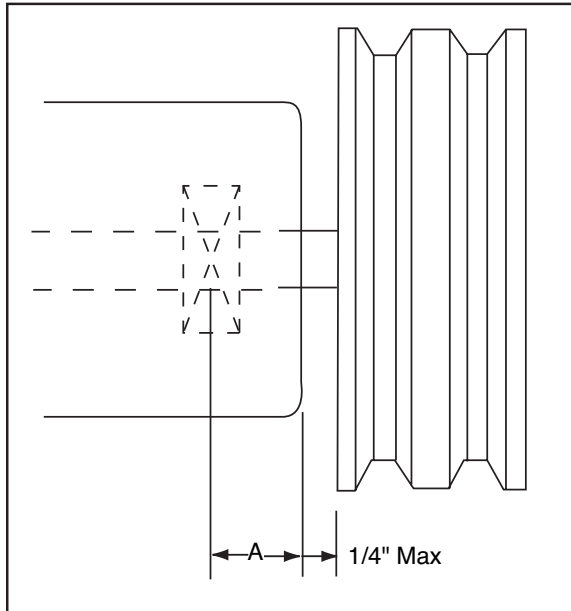

$$\text{Belt Pull lbs} = \frac{252100 \cdot \text{Motor HP}}{\text{Blower RPM} \cdot \text{Sheave Diameter}}$$

$$\text{Shaft Load (lb.in)} = \text{Belt Pull} \cdot \left( A + \frac{1}{4} + \frac{\text{Sheave Width}}{2} \right)$$

Frame Size	Dimension "A"	Max Allowable Shaft Load (lb-in)	Min Sheave Diameter
47	1.02	650	5.00

**NOTE:**

Arc of sheave belt contact on the smaller sheave not to be less than 170°  
 Driver to be installed on the inlet side for vertical units, and on the drive shaft side for horizontal units.  
 Roots recommends the use of two or more 3V, 5V or 8V matched set or banded belts and sheaves.

**Specified Lubricants**

**ROOTS Synthetic Oil: ISO-VG-320 Grade**

	Part Number
Quart	13106004
Gallon	13106005
Case (12 qts)	13106007

**ROOTS Synthetic Oil: ISO-VG-220 Grade**

	Part Number
Quart	13106001
Gallon	13106002
Case (12 qts)	13106008

**ROOTS Synthetic Oil: ISO-VG-150 Grade**

	Part Number
Quart	13106020
Gallon	13106021
Case (12 qts)	13106023
5 Gallon Pail	13106022
55 Gallon Drum	13106025

Drive End Breather Orientation for URA-DSL blowers with Oil Lube

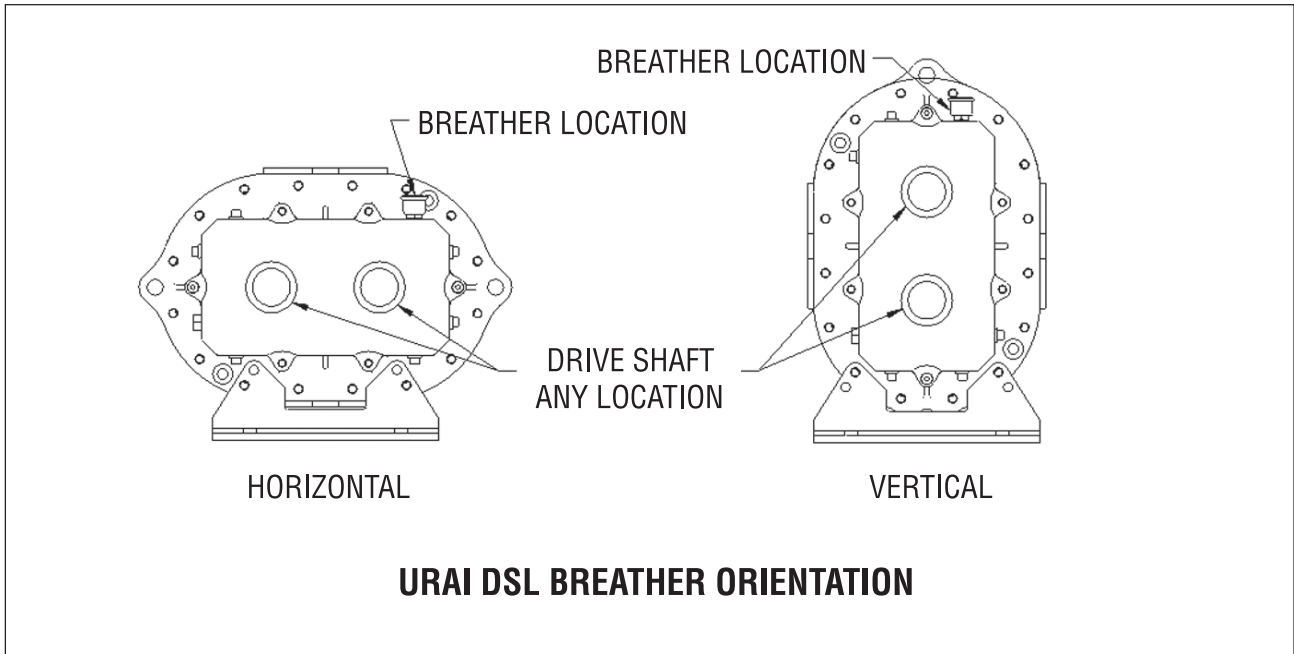

Table 1 - URAI, URAI-DSL Blowers,  
Maximum Allowable Operating Conditions

Frame Size	Gear Diameter (Inch)	Speed RPM	Temp. Rise Deg F (Deg C)	Delta Pressure PSI (mbar)	Inlet Vacuum INHG (mbar)
47	4	3,600	225 (125)	7 (483)	15 (500)

**Table 2 - Recommended Oil Grades**

Ambient Temperature °F (°C)	ISO Viscosity No.
Above 90° (32°)	320
32° to 90° (0° to 32°)	220
0° to 32° (-18° to 0°)	150
Below 0° (-18°)	100

Ambient temperature is defined as the temperature of the space in which the blower and drive are located.

**Table 3 - Approximate Oil Sump Capacities**

These capacities are provided to assist in stocking the correct amount of oil. Exact sump capacities may differ slightly. See "Lubrication" section for proper filling instructions.

**URAI-DSL Splash Lubricated Blowers**

Frame Size	Gear End Capacity Fl. Oz (Liters)	Drive End Capacity Fl. Oz. (Liters)
47	22.8 (.67)	10.8 (.32)

Basic Connection & Drive Shaft Information

**URAI DSL AIR BLOWERS (with Dual Splash Lubrication DSL)**

BOM#	FRAME SIZE	INLET/DISCHARGE CONN.	SHAFT DIAMETER	BARE WEIGHT
T30354020	47	3" NPT	.0875"	132

Universal RAI air blowers include detachable mounting feet which permit vertical or horizontal installation. The units are center timed for rotation in either direction. The bearings on the URAI are grease lubricated on the drive end and splash lubricated on the gear end. The URAI-DSL is splash lubricated on BOTH ends.

**PAGE LEFT BLANK**

# OPERATOR'S MANUAL

# KUBOTA DIESEL ENGINE

MODEL V1505-E

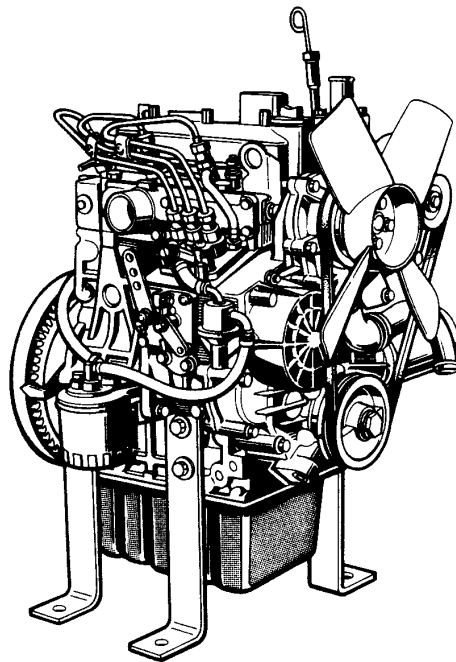

D-2107

*READ AND SAVE THIS BOOK*

**Kubota**



# CONTENTS

## ▲ SAFE OPERATION..... ▲ -1

### SERVICING OF THE ENGINE ..... 1

#### Operation Section

### NAMES OF PARTS ..... 2

### PRE-OPERATION CHECK ..... 3

#### BREAK-IN ..... 3

#### DAILY CHECK ..... 3

### OPERATING THE ENGINE ..... 4

#### STARTING THE ENGINE (NORMAL) ..... 4

#### COLD WEATHER STARTING ..... 5

#### STOPPING THE ENGINE ..... 6

#### CHECKS DURING OPERATION ..... 6

##### Radiator Cooling water (Coolant) ..... 6

##### Oil pressure lamp ..... 6

##### Fuel ..... 7

##### Color of exhaust ..... 7

##### Immediately stop the engine if; ..... 7

#### REVERSED ENGINE REVOLUTION AND REMEDIES ..... 7

##### How to tell when the engine starts running backwards ..... 7

##### Remedies ..... 7

#### Maintenance Section

### MAINTENANCE ..... 8

#### SERVICE INTERVALS ..... 8

### PERIODIC SERVICE ..... 10

#### FUEL ..... 10

##### Fuel level check and refueling ..... 10

##### Air bleeding the fuel system ..... 11

##### Checking the fuel pipes ..... 12

##### Cleaning the fuel filter pot ..... 12

##### Fuel filter cartridge replacement ..... 13

### ENGINE OIL ..... 13

#### Checking oil level and adding

##### engine oil ..... 13

#### Changing engine oil ..... 14

#### Replacing the oil filter cartridge ..... 15

### RADIATOR ..... 15

#### Checking coolant level, adding

##### coolant ..... 16

#### Changing coolant ..... 17

#### Remedies for quick decrease of coolant ..... 17

#### Checking radiator hoses and clamp ..... 17

#### Precaution at overheating ..... 17

#### Cleaning radiator core (outside) ..... 17

#### Anti-freeze ..... 18

#### Radiator cement ..... 18

### AIR CLEANER ..... 19

#### Evacuator valve ..... 19

#### Dust indicator (optional) ..... 19

#### For the air cleaner with a dust cup (optional) ..... 20

### BATTERY ..... 20

#### Battery charging ..... 20

#### Direction for long term storage ..... 21

### ELECTRIC WIRING ..... 22

### FAN BELT ..... 22

#### Adjusting Fan Belt Tension ..... 22

### CARRIAGE AND STORAGE ..... 23

#### CARRIAGE ..... 23

#### STORAGE ..... 23

### TROUBLESHOOTING ..... 24

### SPECIFICATIONS ..... 26

### WIRING DIAGRAMS ..... 28



# SAFETY FIRST

This symbol, the industry's "Safety Alert Symbol", is used throughout this manual and on labels on the machine itself to warn of the possibility of personal injury. Read these instructions carefully. It is essential that you read the instructions and safety regulations before you attempt to assemble or use this unit.



**DANGER :** Indicates an imminently hazardous situation which, if not avoided, will result in death or serious injury.



**WARNING :** Indicates a potentially hazardous situation which, if not avoided, COULD result in death or serious injury.



**CAUTION:** Indicates a potentially hazardous situation which, if not avoided, MAY result in minor or moderate injury.

**IMPORTANT :** Indicates that equipment or property damage could result if instructions are not followed.

**NOTE :** Gives helpful information.



# SAFE OPERATION

Careful operation is your best insurance against an accident. Read and understand this section carefully before operating the engine. All operators, no matter how much experience they may have had, should read this and other related manuals before operating the engine or any equipment attached to it. It is the owner's obligation to instruct all operators in safe operation.

Be sure to observe the following for safe operation.

## OBSERVE SAFETY INSTRUCTIONS

- Read and understand carefully this "OPERATOR'S MANUAL" and "LABELS ON THE ENGINE" before attempting to start and operate the engine.
- Learn how to operate and work safely. Know your equipments and its limitations. Always keep the engine in good condition.
- Before allowing other people to use your engine, explain how to operate and have them read this manual before operation.
- DO NOT modify the engine by yourself. UNAUTHORIZED MODIFICATIONS to the engine may impair the function and/or safety and affect engine life.

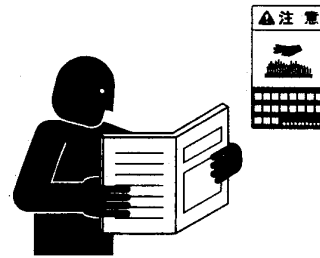

F-8822

## WEAR SAFETY CLOTHING

- DO NOT wear loose, torn or bulky clothing around the machine that may catch on working controls and projections causing personal injury.
- Use additional safety items, e.g. hard hat, safety protection, gloves, etc., as appropriate or required.
- DO NOT operate machine or any equipment attached to it while under alcohol, medication, or other drugs, or while fatigued.
- DO NOT wear radio or music headphones while operating engine.



B-1501 改

## CHECK BEFORE OPERATION & STARTING THE ENGINE

- Be sure to check the engine before operation. If something is wrong with the engine, do not fail to repair it quickly.
- Keep all guards and shields in place before operating the engine. Replace any that are damaged or missing.
- Check to see if there is a safe distance from the engine before starting.
- Always keep the engine at least 3 feet (1 meter) away from buildings and other facilities.
- DO NOT allow children or livestock to approach the machine while the engine is running.
- DO NOT start the engine by shorting across starter terminals. The machine may start in gear and move.



B-1497

## KEEP AROUND THE ENGINE CLEAN

- Be sure to stop the engine before cleaning.
- Keep the engine clean and free of accumulated dirt, grease and trash to avoid a fire. Store flammable fluids away from sparks and fire.
- DO NOT stop the engine without idling; Temperatures around the engine rise suddenly. Keep the engine idling for over about 5 minutes before stopping.



B-1500

**SAFE HANDLING OF FUEL AND LUBRICANTS**  
**—KEEP OFF FIRE—**

- Always stop the engine before refueling or/and lubricating.
- DO NOT smoke or allow flames or sparks in your working area. Fuel is extremely flammable and explosive under certain conditions.
- Refuel at a well ventilated and open place. When fuel and lubricants are spilled, refuel after letting engine cool off.
- DO NOT mix gasoline or alcohol with diesel fuel. The mixture can cause a fire.

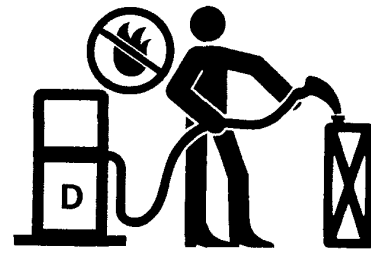

B-1499

**EXHAUST GASES & FIRE PREVENTION**

- Engine exhaust fumes can be very harmful if allowed to accumulate. Be sure to run the engine in a well ventilated place and where there are no people or livestock near the engine.
- The exhaust gas from the muffler is very hot. To prevent a fire, do not expose dry grass, mowed grass, oil and any other combustible materials to exhaust gas. Also, keep the engine and muffler clean all the time.
- To avoid a fire, be alert for leaks of flammables from hoses and lines. Be sure to check for leaks from hoses or pipes, such as fuel and hydraulic by following the maintenance check list.
- To avoid a fire, do not short across power cables and wires. Check to see that all power cables and wirings are in good condition. Keep all power connections clean. Bare wire or frayed insulation can cause a dangerous electrical shock and personal injury.

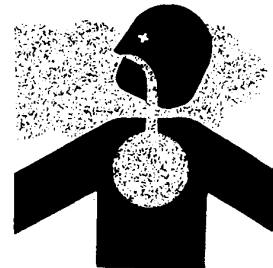

F-8842

**ESCAPING FLUID**

- Relieve all pressure in the air, the oil and the cooling systems before any lines, fittings or related items are removed or disconnected.
- Be alert for possible pressure when disconnecting any device from a system that utilizes pressure. DO NOT check for pressure leaks with your hand. High pressure oil or fuel can cause personal injury.
- Escaping hydraulic fluid under pressure has sufficient force to penetrate skin causing serious personal injury.
- Fluid escaping from pinholes may be invisible. Use a piece of cardboard or wood to search for suspected leaks: do not use hands and body. Use safety goggles or other eye protection when checking for leaks.
- If injured by escaping fluid, see a medical doctor immediately. This fluid can produce gangrene or severe allergic reaction.

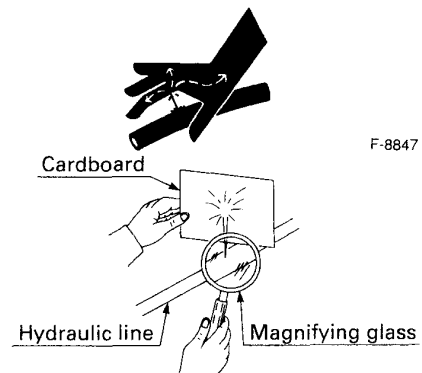

F-8847

F-2359

### CAUTIONS AGAINST BURNS & BATTERY EXPLOSION

- To avoid burns, be alert for hot components, e.g. muffler, muffler cover, radiator, pipings, engine body, coolants, engine oil, etc. during operation and just after the engine has been shut off.
- DO NOT remove the radiator cap while the engine is running or immediately after stopping. Otherwise hot water will spout out from radiator. Wait for more than ten minutes to cool the radiator, before removing the cap.
- Make sure to shut the drain valve of coolant and oil to close pressure cap, to fasten pipe band before operating. If those parts are taken off, or loosen, it will result in serious personal injury.
- The battery presents an explosive hazard. When the battery is being activated, hydrogen and oxygen gases are extremely explosive.
- Do not use or charge the battery if its fluid level stands below the LOWER mark. Otherwise, the component parts may deteriorate earlier than expected, which may shorten the service life or cause an explosion. Immediately, add distilled water until the fluid level is between the UPPER and LOWER levels.
- Keep sparks and open flames away from the battery, especially when charging the battery. DO NOT strike a match near the battery.
- DO NOT check battery charge by placing a metal object across the terminals. Use a voltmeter or hydrometer.
- DO NOT charge battery if frozen. It can be explosive. When frozen, warm the battery up more than 16°C ( 61°F ).

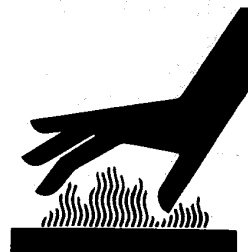

B-1502

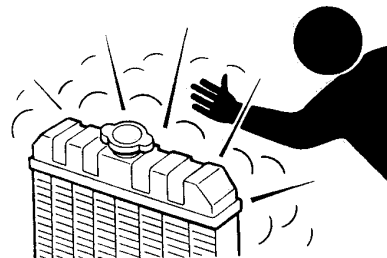

B-1503

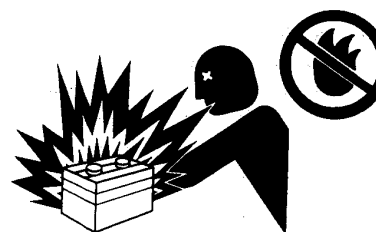

F-8836

### HANDS AND BODY AWAY FROM THE ROTATING PARTS

- Be sure to stop the engine before checking or adjusting belt tension and cooling fan.
- Keep your hands and body away from the rotating parts, such as cooling fan, V-belt, fan drive V-belt pulley or flywheel causing personal injury.
- DO NOT run the engine with installed safety guards detached. Install safety guards securely during operation.



B-1505



B-1506

### ANTI-FREEZE & DISPOSAL OF FLUIDS

- Anti-freeze contains poison. Wear rubber gloves to avoid personal injury. In case of contact with skin, wash it off immediately.
- DO NOT mix different types of Anti-freeze. The mixture can produce chemical reaction causing harmful substances. Use approved or genuine KUBOTA Anti-freeze.
- Be mindful of the environment and the ecology. Before draining any fluids, find out the correct way of disposing of them. Observe the relevant environmental protection regulations when disposing of oil, fuel, coolant, brake fluid, filters and batteries.
- When draining fluids from the engine, place some container underneath the engine body.
- DO NOT pour waste onto the grounds, down a drain, or into any water source.



B-1508

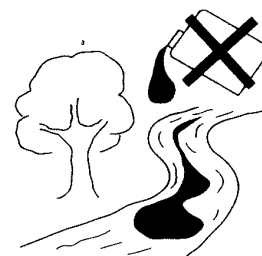

B-1507

### CONDUCTING SAFETY CHECKS & MAINTENANCE

- When checking engine or servicing, place the engine on a wide and level ground. DO NOT work on anything that is supported ONLY by lift jacks or a hoist. Always use blocks or correct stands to support the engine before servicing.
- Detach the battery from the engine before conducting service. Put a "DO NOT OPERATE!" tag in the key switch to avoid accidental starting.
- To avoid sparks from an accidental short circuit always disconnect the battery's ground cable ⊖ first and connect it last.
- Be sure to stop the engine and remove the key when conducting daily and periodic maintenance, servicing and cleaning.
- Check or conduct maintenance after the engine, coolant, muffler, or muffler cover have been cooled off completely.
- Always use the appropriate tools and jig-fixture in good condition when performing any service work. Make sure you understand how to use them before service.
- Use ONLY correct engine barring techniques for manually rotating the engine. DO NOT attempt to rotate the engine by pulling or prying on the cooling fan and V-belt. This practise can cause serious personal injury or premature machine damage to the cooling fan.
- Replace fuel pipes and lubricant pipes with their hose clamps every 2 years or earlier whether they are damaged or not. They are made of rubber and are aged gradually.
- When servicing is performed together by two or more persons, take care to perform all work safely.
- Keep first aid kit and fire extinguisher handy at all times.

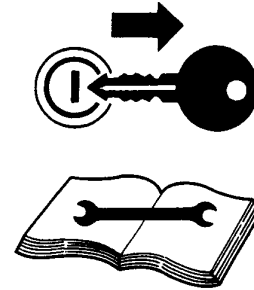

B-1509

### WARNING AND CAUTION LABELS

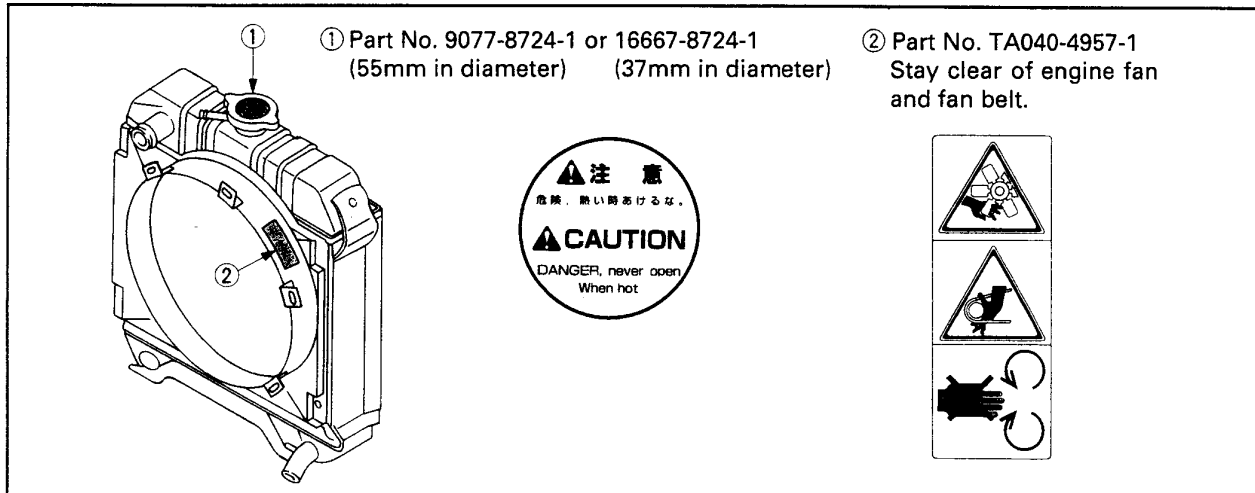

### CARE OF WARNING AND CAUTION LABELS

- (1) Keep warning and caution labels clean and free from obstructing material.
- (2) Clean warning and caution labels with soap and water, dry with a soft cloth.
- (3) Replace damaged or missing warning and caution labels with new labels from your local KUBOTA dealer.
- (4) If a component with warning and caution label(s) affixed is replaced with new part, make sure new label(s) is (are) attached in the same location(s) as the replaced component.
- (5) Mount new warning and caution labels by applying on a clean dry surface and pressing any bubbles to outside edge.

# SERVICING OF THE ENGINE

Your dealer is interested in your new engine and has the desire to help you get the most value from it. After reading this manual thoroughly, you will find that you can do some of the regular maintenance yourself.

However, when in need of parts or major service, be sure to see your KUBOTA dealer.

For service, contact the KUBOTA Dealership from which you purchased your engine or your local KUBOTA dealer.

When in need of parts, be prepared to give your dealer the engine serial number.

Locate the serial number now and record them in the space provided.

Type	Serial No.
------	------------

Engine \_\_\_\_\_

Date of Purchase \_\_\_\_\_

Name of Dealer \_\_\_\_\_

(To be filled in by purchaser)

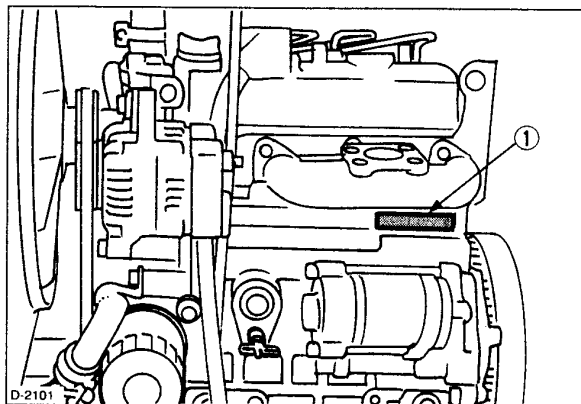

(1) Engine serial number

# NAMES OF PARTS

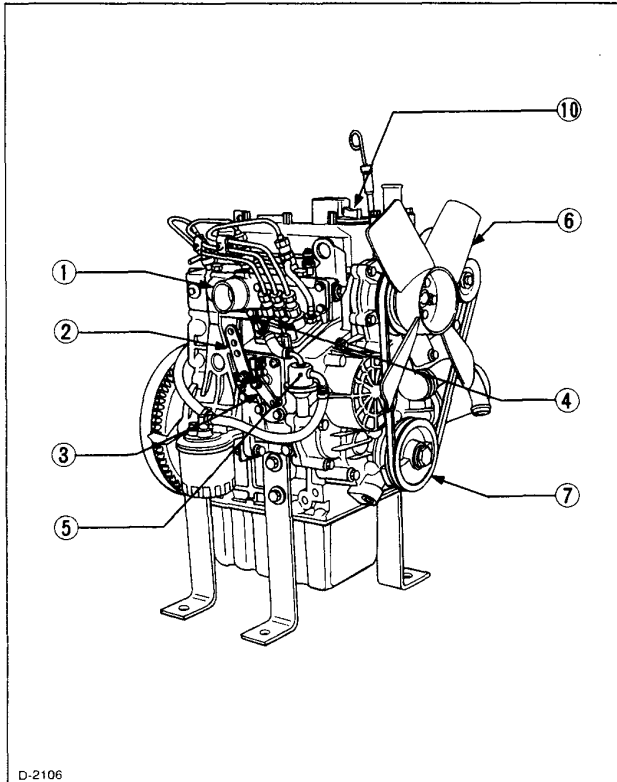

D-2106

- (1) Intake manifold
- (2) Speed control lever
- (3) Engine stop lever
- (4) Injection pump
- (5) Fuel feed pump
- (6) Cooling fan
- (7) Fan drive pulley
- (8) Oil filter cartridge
- (9) Water drain cock

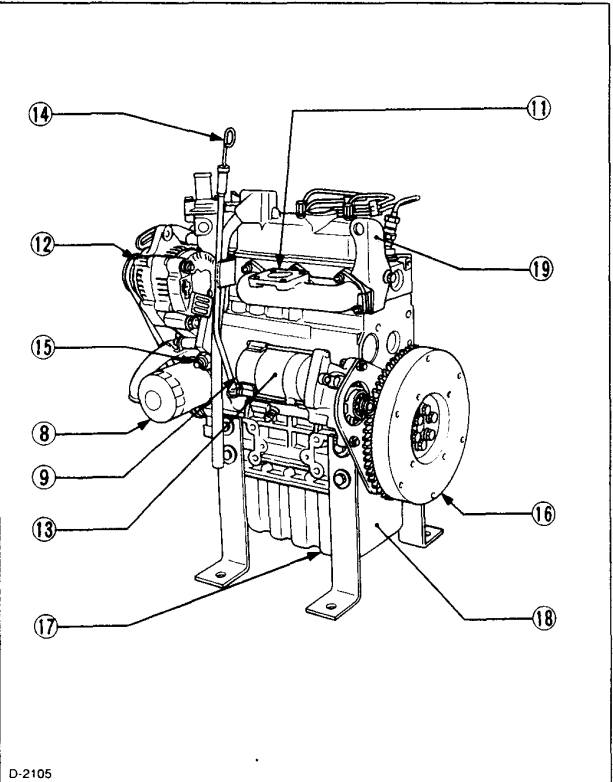

D-2105

- (10) Oil filler plug
- (11) Exhaust manifold
- (12) Alternator
- (13) Starter
- (14) Oil level gauge
- (15) Oil pressure switch
- (16) Flywheel
- (17) Oil drain plug
- (18) Oil pan
- (19) Engine hook



# PRE-OPERATION CHECK

## BREAK-IN

During the engine break-in period, observe the following by all means:

1. Change engine oil and oil filter cartridge after the first 50 hours of operation (See "ENGINE OIL" in PERIODIC SERVICE Section).
2. When ambient temperature is low, operate the machine after the engine has been completely warmed up.

## DAILY CHECK

To prevent trouble from occurring, it is important to know the conditions of the engine well. Check it before starting.



### CAUTION

To avoid personal injury:

- Be sure to install shields and safeguards attached to the engine when operating.
- Stop the engine at a flat and wide space when checking.
- Keep dust or fuel away from the battery, wiring, muffler and engine to prevent a fire. Check and clear them before operating everyday. Pay attention to the heat of the exhaust pipe or exhaust gas so that it can not ignite trash.

Item		Ref. page
1. Parts which had trouble in previous operation.		-
2. By walking around the machine	(1) Oil or water leaks	13 to 18
	(2) Engine oil level and contamination	13, 14
	(3) Amount of fuel	10
	(4) Amount of coolant	15 to 18
	(5) Dust in air cleaner dust cup	19, 20
	(6) Damaged parts and loosened bolts and nuts	-
3. By inserting the key into the starter switch	(1) Proper functions of meters and pilot lamps; no stains on these parts	-
	(2) Proper functions of glow lamp timer	-
4. By starting the engine	(1) Color of exhaust fumes	7
	(2) Unusual engine noise	7

# OPERATING THE ENGINE

## STARTING THE ENGINE (NORMAL)



### CAUTION

To avoid personal injury:

- Do not allow children to approach the machine while the engine is running.
- Be sure to install the machine on which the engine is installed, on a flat place.
- Do not run the engine on gradients.
- Do not run the engine in an enclosed area. Exhaust gas can cause air pollution and exhaust gas poisoning.
- Keep your hands away from rotating parts (such as fan, pulley, belt, flywheel etc.) during operation.
- Do not operate the machine while under the influence of alcohol or drugs.
- Do not wear loose, torn or bulky clothing around the machine. It may catch on moving parts or controls, leading to the risk of accident. Use additional safety items, e.g. hard hat, safety boots or shoes, eye and hearing protection, gloves, etc., as appropriate or required.
- Do not wear radio or music headphones while operating engine.
- Check to see if it is safe around the engine before starting.
- Reinstall safeguards and shields securely and clear all maintenance tools when starting the engine after maintenance.

### IMPORTANT:

- Do not use ether or any starting fluid for starting the engine, or a severe damage will occur.
- When starting the engine after a long storage (of more than 3 months), first set the stop lever to the "STOP" position and then activate the starter for about 10 seconds to allow oil to reach every engine part.

### 1. Set the fuel lever to "ON".

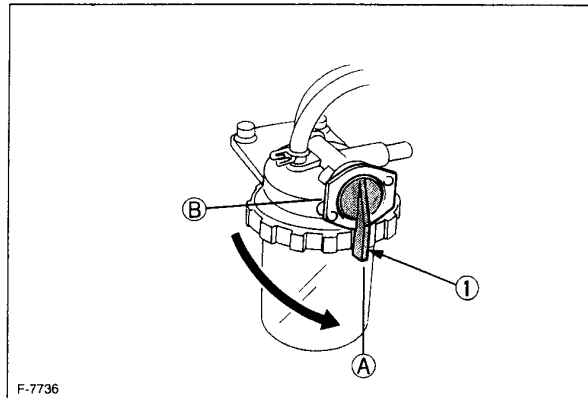

(1) Fuel lever

(A) "ON"

(B) "OFF"

### 2. Place the engine stop lever in the "START" position.

### 3. Place the speed control lever at more than half "OPERATION".

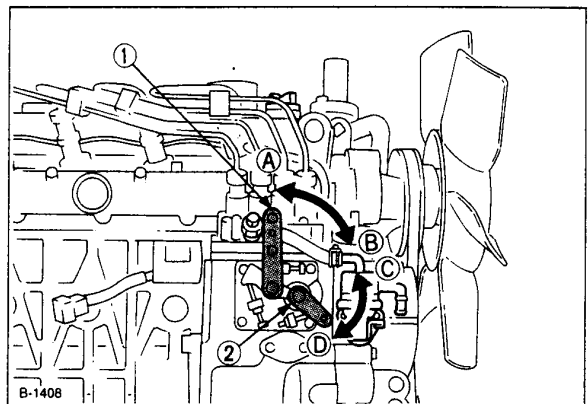

(1) Speed control lever

(A) "IDLING"

(2) Engine stop lever

(B) "OPERATION"

(C) "START"

(D) "STOP"

4. Insert the key into the key switch and turn it "ON".

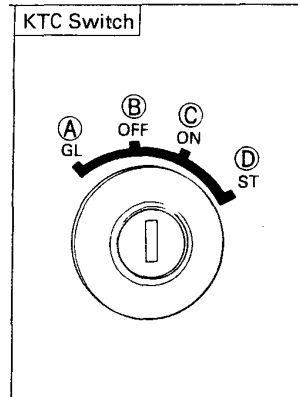

(A) "PREHEATING"  
 (B) "SWITCHED OFF"  
 (C) "OPERATION"  
 (D) "STARTING"

5. Turn the starter switch to the "PREHEATING" position to allow the glow lamp to redden.
6. Turn the key to the "STARTING" position and the engine should start. Release the key immediately when the engine starts.
7. Check to see that the oil pressure lamp and charge lamp are off. If the lamps are still on, immediately stop the engine, and determine the cause.  
 (See "CHECKS DURING OPERATION" in OPERATING THE ENGINE Section)

**NOTE:**

- If the oil pressure lamp should be still on, immediately stop the engine and check;
  - if there is enough engine oil.
  - if the engine oil has dirt in it.
  - if the wiring is faulty.

8. Warm up the engine at medium speed without load.

**IMPORTANT:**

- If the glow lamp should redden too quickly or too slowly, immediately ask your KUBOTA dealer to check and repair it.
- If the engine does not catch or start at 10 seconds after the starter switch is set at "STARTING", wait for another 30 seconds and then begin the engine starting sequence again. Do not allow the starter motor to run continuously for more than 20 seconds.

**COLD WEATHER STARTING**

If the ambient temperature is below\* -5°C(23°F) and the engine is very cold, start it in the following manner:

Take steps (1) through (4) left.

5. Turn the key to "PREHEATING(GLOW)" position and keep it there for a certain period mentioned below.

**IMPORTANT:**

- Shown below are the standard preheating times for various temperatures. This operation, however, is not required, when the engine is warmed up.

Ambient temperature	Preheating time	
	Ordinary heat type	With glow lamp timer
Above 10°C (50°F)	NO NEED	
10°C (50°F) to -5°C (23°F)	Approx. 5 seconds	See NOTE:
*Below -5°C (23°F)	Approx. 10 seconds	
Limit of continuous use	20 seconds	

**NOTE:**

- In case of installing standard glow lamp, glow lamp goes off after about 6 seconds, when the starter switch key is turned to preheating position. However if necessary, keep the starter switch key at preheating position for longer time, according to the left recommendation.

6. Turn the key to "ST (STARTING)" position and the engine should start.

(If the engine fails to start after 10 seconds, turn off the key for 5 to 30 seconds. Then repeat steps (5) and (6).)

**IMPORTANT:**

- Do not allow the starter motor to run continuously for more than 20 seconds.

## STOPPING THE ENGINE

1. Return the speed control lever to low idle, and run the engine under idling conditions.
2. Set the engine stop lever to the "STOP" position.
3. With the starter switch placed at the "OFF" position, remove the key. (Be sure to return the engine stop lever to the "START" position to be ready for the next start.)

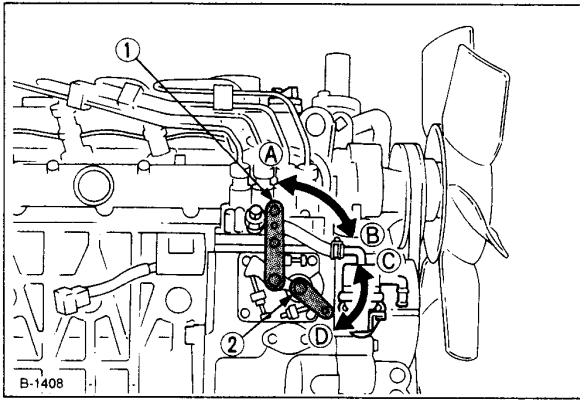

- |                         |                 |
|-------------------------|-----------------|
| (1) Speed control lever | (A) "IDLING"    |
| (2) Engine stop lever   | (B) "OPERATION" |
|                         | (C) "START"     |
|                         | (D) "STOP"      |

### IMPORTANT

- If equipped with a turbo-charger, allow the engine to idle for 5 minutes before shutting it off after a full load operation. Failure to do so may lead to turbo-charger trouble.

## CHECKS DURING OPERATION

While running, make the following checks to see that all parts are working correctly.

### ■ Radiator Cooling water (Coolant)



#### WARNING

To avoid personal injury:

- Do not remove radiator cap until coolant temperature is well below its boiling point. Then loosen cap slightly to the stop position, to relieve any pressure, before removing cap completely.

When the engine overheats and hot coolant overflows through the radiator and hoses, stop the engine immediately and make the following checks to determine the cause of trouble:

#### Check item

1. Check to see if there is any coolant leak;
2. Check to see if there is any obstacle around the cooling air inlet or outlet;
3. Check to see if there is any dirt or dust between radiator fins and tube;
4. Check to see if the fan belt is too loose;
5. Check to see if radiator water pipe is clogged; and
6. Check to see if anti-freeze is mixed to a 50/50% mix of water and anti-freeze.

### ■ Oil pressure lamp

The lamp lights up to warn the operator that the engine oil pressure has dropped below the prescribed level. If this should happen during operation or should not go off even after the engine is accelerated more than 1000rpm, immediately stop the engine and check the following:

1. Engine oil level (See "ENGINE OIL" in MAINTENANCE Section).
2. Lubricant system (See "ENGINE OIL" in MAINTENANCE Section).

## ■ Fuel



### CAUTION

To avoid personal injury:

- Fluid escaping from pinholes may be invisible. Do not use hands to search for suspected leaks; Use a piece of cardboard or wood, instead. If injured by escaping fluid, see a medical doctor at once. This fluid can produce gangrene or a severe allergic reaction.
- Check any leaks from fuel pipes or fuel injection pipes. Use eye protection when checking for leaks.

Be careful not to empty the fuel tank. Otherwise air may enter the fuel system, requiring fuel system bleeding. (See "FUEL" in MAINTENANCE Section).

## ■ Color of exhaust

While the engine is run within the rated output range:

- The color of exhaust remains colorless.
- If the output slightly exceeds the rated level, exhaust may become a little colored with the output level kept constant.
- If the engine is run continuously with dark exhaust emission, it may lead to trouble with the engine.

## ■ Immediately stop the engine if;

- The engine suddenly slow down or accelerates.
- Unusual noises suddenly appear.
- Exhaust fumes suddenly become very dark.
- The oil pressure lamp or the water temperature alarm lamp lights up.

## REVERSED ENGINE REVOLUTION AND REMEDIES



### CAUTION

To avoid personal injury:

- Reversed engine operation can make the machine reverse and run it backwards. It may lead to serious trouble.
- Reversed engine operation may make exhaust gas gush out into the intake side and ignite the air cleaner; It could catch fire.

Reversed engine revolution must be stopped immediately since engine oil circulation is cut quickly, leading to serious trouble.

## ■ How to tell when the engine starts running backwards

1. Lubricating oil pressure drops sharply. Oil pressure warning light, if used, will light.
2. Since the intake and exhaust sides are reversed, the sound of the engine changes, and exhaust gas will come out of the air cleaner.
3. A louder knocking sound will be heard when the engine starts running backwards.

## ■ Remedies

1. Immediately set the engine stop lever to the "STOP" position to stop the engine.
2. After stopping the engine, check the air cleaner, intake rubber tube and other parts and replace parts as needed.

# MAINTENANCE



**CAUTION**

To avoid personal injury:

- Be sure to conduct daily checks, periodic maintenance, refueling or cleaning on a level surface with the engine shut off and remove the key.
- Before allowing other people to use your engine, explain how to operate, and have them read this manual before operation.
- When cleaning any parts, do not use gasoline but use regular cleanser.
- Always use proper tools, that are in good condition. Make sure you understand how to use them, before performing any service work.
- When installing, be sure to tighten all bolts lest they should be loose. Tighten the bolts by the specified torque.
- Do not put any tools on the battery, or battery terminals may short out. Severe burns or fire could result. Detach the battery from the engine before maintenance.
- Do not touch muffler or exhaust pipes while they are hot; Severe burns could result.

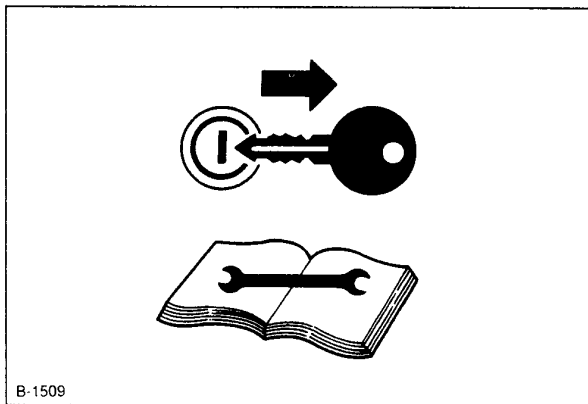

B-1509

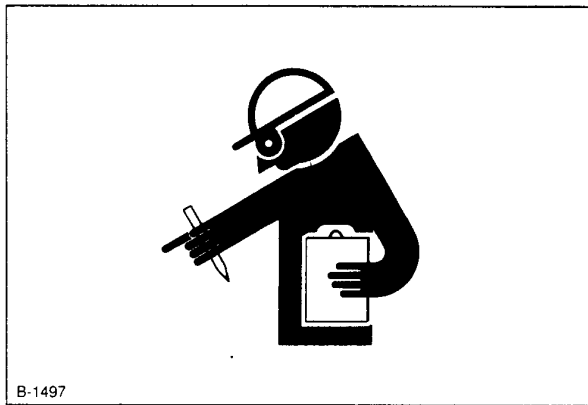

B-1497

## SERVICE INTERVALS

Observe the following for service and maintenance.

The lubricating oil change intervals listed in the table below are for Classes CF, CE and CD lubricating oils of API classification with a low-sulfur fuel in use. If the CF-4 or CG-4 lubricating oil is used with a high-sulfur fuel, change the lubricating oil at shorter intervals than recommended in the table below depending on the operating condition.

Interval	Item	Ref. Page		
Every 50 hours	Check of fuel pipes and clamp bands	12		@
See NOTE:	Change of engine oil	13, 14	⊙	
Every 100 hours	Cleaning of air cleaner element	19, 20	*1	@
	Cleaning of fuel filter	12		
	Check of battery electrolyte level	20		
	Check of fan belt tightness	22		
Every 200 hours	Check of radiator hoses and clamp bands	17		
	Replacement of oil filter cartridge	15	⊙	
	Check of intake air line	—		@

Interval	Item	Ref. Page		
Every 400 hours	Replacement of fuel filter cartridge	13		@
Every 500 hours	Removal of sediment in fuel tank	—		
	Cleaning of water jacket (radiator interior)	15 to 18		
	Replacement of fan belt	22		
Every one or two months	Recharging of battery	20		
Every year	Replacement of air cleaner element	19, 20	*2	@
	Check of damage in electric wiring and loose connections	—		
Every 800 hours	Check of valve clearance	24		
Every 1500 hours	Check of fuel injection nozzle injection pressure	—	*3	@
Every 3000 hours	Check of turbo charger	—	*3	@
	Check of injection pump	—	*3	@
	Check of fuel injection timer	—	*3	@
Every two years	Change of radiator coolant (L.L.C.)	17		
	Replacement of battery	20		
	Replacement of radiator hoses and clamp bands	18		
	Replacement of fuel pipes and clamp bands	12	*3	@
	Replacement of intake air line	—	*4	@

**IMPORTANT**

- The jobs indicated by © must be done after the first 50 hours of operation.
- \*1 Air cleaner should be cleaned more often in dusty conditions than in normal conditions.
- \*2 After 6 times of cleaning.
- \*3 Consult your local KUBOTA Dealer for this service.
- \*4 Replace only if necessary.
- When the battery is used for less than 100 hours in a year, check its electrolyte yearly. (for refillable battery's only)
- The items listed above (@ marked) are registered as emission related critical parts by KUBOTA in the U.S. EPA nonroad emission regulation. As the engine owner, you are responsible for the performance of the required maintenance on the engine according to the above instruction.  
Please see the Warranty Statement in detail.

**NOTE:**

- Changing interval of engine oil depends on the conditions below.

Models	Oil pan depth	
	Above 125 mm (4.9 in.)	※below 101 mm (4.0 in.)
All models	200 Hrs	150 Hrs
Initial	50 Hrs	

- ※ 101mm oil pan depth is optional.
- ※※ Standard replacement interval
  - API service classification: above CD grade
  - Ambient temperature: below 35 °C (95 °F)

**NOTE:**

**Lubricating oil**

With the emission control now in effect, the CF-4 and CG-4 lubricating oils have been developed for use of a low-sulfur fuel on on-road vehicle engines. When an

off-road vehicle engine runs on a high-sulfur fuel, it is advisable to employ the CF, CD or CE lubricating oil with a high total base number. If the CF-4 or CG-4 lubricating oil is used with a high-sulfur fuel, change the lubricating oil at shorter intervals.

- **Lubricating oil recommended when a low-sulfur or high-sulfur fuel is employed.**

○ : Recommendable × : Not recommendable

Lubricating oil class	Fuel		Remarks
	Low sulfur	High sulfur	
CF	○	○	TBN ≥ 10
CF-4	○	×	
CG-4	○	×	

# PERIODIC SERVICE

## FUEL

Fuel is flammable and can be dangerous. You should handle fuel with care.



### CAUTION

To avoid personal injury:

- Do not mix gasoline or alcohol with diesel fuel. This mixture can cause an explosion.
- Be careful not to spill fuel during refueling. If fuel should spill, wipe it off at once, or it may cause a fire.
- Do not fail to stop the engine before refueling. Keep the engine away from the fire.
- Be sure to stop the engine while refueling or bleeding and when cleaning or changing fuel filter or fuel pipes. Do not smoke when working around the battery or when refueling.
- Check the above fuel systems at a well ventilated and wide place.
- When fuel and lubricant are spilled, refuel after letting the engine cool off.
- Always keep spilled fuel and lubricant away from engine.

### Fuel level check and refueling

1. Check to see that the fuel level is above the lower limit of the fuel level gauge.
2. If the fuel is too low, add fuel to the upper limit. Do not overfill.

No.2-D is a distillate fuel oil of lower volatility for engines in industrial and heavy mobile service.

(SAE J313 JUN87)

Grade of Diesel Fuel Oil According to ASTM D975

Flash Point, °C (°F)	Water and Sediment, volume %	Carbon Residue on, 10 percent Residuuum, %	Ash, weight %
Min	Max	Max	Max
52 (125)	0.05	0.35	0.01

Distillation Temperatures, °C (°F) 90% Point		Viscosity Kinematic cSt or mm <sup>2</sup> /s at 40°C		Viscosity Sayboit, SUS at 100°F		Sulfur, weight %	Copper strip Corrosion	Cetane Number
Min	Max	Min	Max	Min	Max	Max	Max	Min
282 (540)	338 (640)	1.9	4.1	32.6	40.1	0.50	No.3	40

The cetane number is required not to be less than 45.

### IMPORTANT:

- Be sure to use a strainer when filling the fuel tank, or dirt or sand in the fuel may cause trouble in the fuel injection pump.
- For fuel, always use diesel fuel. You are required not to use alternative fuel, because its quality is unknown or it may be inferior in quality. Kerosene, which is very low in cetane rating, adversely affects the engine. Diesel fuel differs in grades depending on the temperature.
- Be careful not to let the fuel tank become empty, or air can enter the fuel system, necessitating bleeding before next engine start.



■ Air bleeding the fuel system



**CAUTION**

To avoid personal injury;

- Do not bleed a hot engine as this could cause fuel to spill onto a hot exhaust manifold creating a danger of fire.

Air bleeding of the fuel system is required if;

- after the fuel filter and pipes have been detached and refitted;
- after the fuel tank has become empty; or
- before the engine is to be used after a long storage.

[PROCEDURE (A)] (gravity feed fuel tanks only)

1. Fill the fuel tank to the fullest extent. Open the fuel filter lever.
2. Loosen air vent plug of the fuel filter a few turns.
3. Screw back the plug when bubbles do not come up any more.
4. Open the air vent plug on top of the fuel injection pump.
5. Retighten the plug when bubbles do not come up any more.

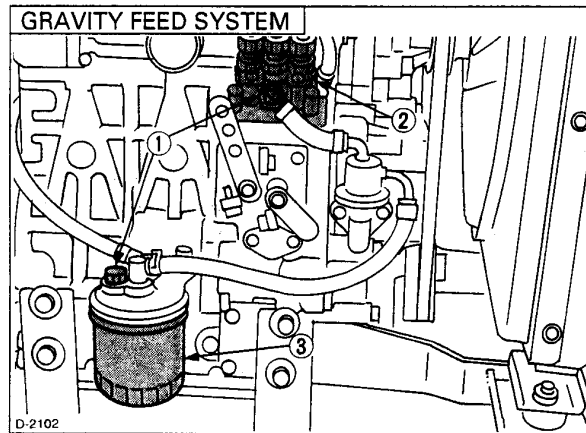

- D-2102
- (1) Air vent plug
  - (2) Injection pump
  - (3) Fuel filter

[PROCEDURE (B)]

(fuel tanks lower than injection pump)

1. For fuel tanks that are lower than the injection pump. The fuel system must be pressurized by the fuel system electric fuel pump.
2. If an electric fuel pump is not used, you must manually actuate the pump by lever to bleed.
3. The primary fuel filter (3) must be on the pressure side of the pump if the fuel tank is lower than the injection pump.
4. To bleed follow (2) through (5) above.

**IMPORTANT:**

- Tighten air vent plug of the fuel injection pump except when bleeding, or it may stop the engine suddenly.

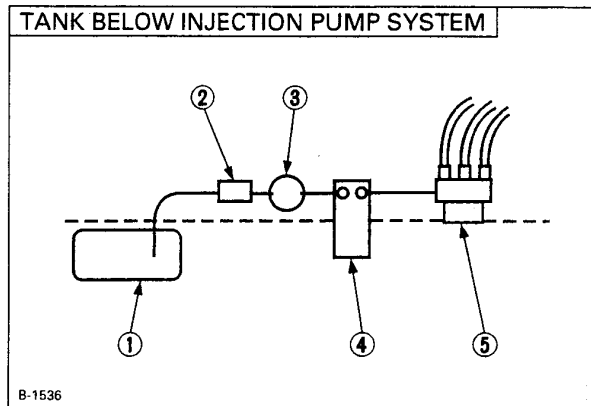

- B-1536
- (1) Fuel tank below injection pump
  - (2) Pre-filter
  - (3) Electric or Mechanical pump
  - (4) Main Filter
  - (5) Injection pump

### ■ Checking the fuel pipes



**CAUTION**

To avoid personal injury:

- Check or replace the fuel pipes after stopping the engine. Broken fuel pipes can cause fires.

Check the fuel pipes every 50 hours of operation.

When if;

1. If the clamp band is loose, apply oil to the screw of the band, and tighten the band securely.
2. If the fuel pipes, made of rubber, become worn out, replace them and the clamp bands every two years.
3. If the fuel pipes and clamp bands are found worn or damaged before two years'time, replace or repair them at once.
4. After replacement of the pipes and bands, air-bleed the fuel system.

**IMPORTANT:**

- When the fuel pipes are not installed, plug them at both ends with clean cloth or paper to prevent dirt from entering. Dirt in the pipes can cause fuel injection pump malfunction.

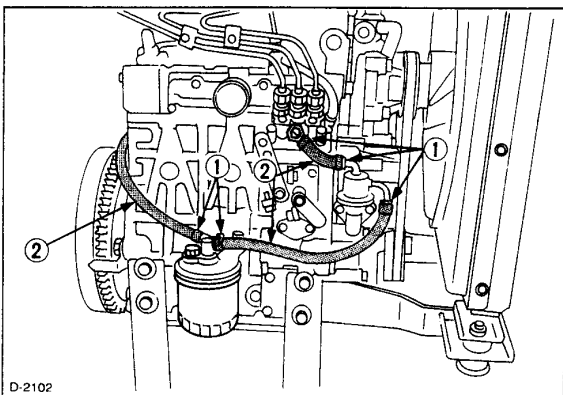

D-2102

- (1) Clamp band  
(2) Fuel pipe

### ■ Cleaning the fuel filter pot

Every 100 hours of operation, clean the fuel filter in a clean place to prevent dust intrusion.

1. Close the fuel filter lever.

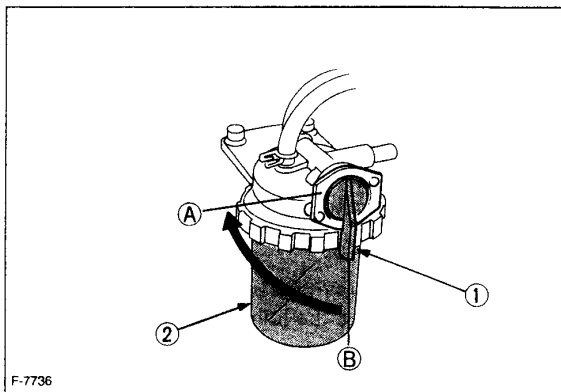

F-7736

- (1) Fuel filter lever (A) "OFF"  
(2) Fuel filter pot (B) "ON"

2. Remove the top cap, and rinse the inside with diesel fuel.
3. Take out the element, and rinse it with diesel fuel.
4. After cleaning, reinstall the fuel filter, keeping out of dust and dirt.
5. Air-bleed the injection pump.

**IMPORTANT:**

- Entrance of dust and dirt can cause a malfunction of the fuel injection pump and the injection nozzle. Wash the fuel filter cup periodically.

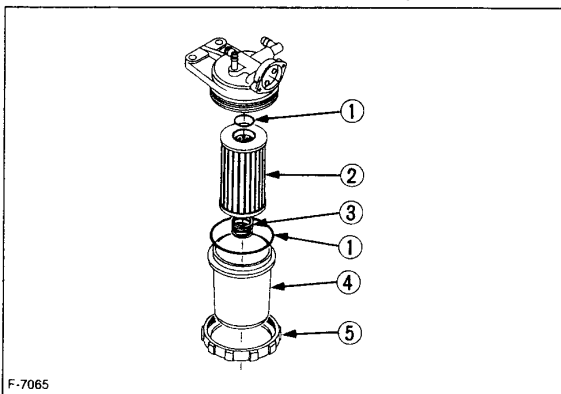

F-7065

- (1) O ring  
(2) Filter element  
(3) Spring  
(4) Filter bowl  
(5) Screw ring

### Fuel filter cartridge replacement

1. Replace the fuel filter cartridge with a new one every 400 operating hours.
2. Apply fuel oil thinly over the gasket and tighten the cartridge into position by hand-tightening only.
3. Finally, vent the air.

#### IMPORTANT:

- Replace the fuel filter cartridge periodically to prevent wear of the fuel injection pump plunger or the injection nozzle, due to dirt in the fuel.

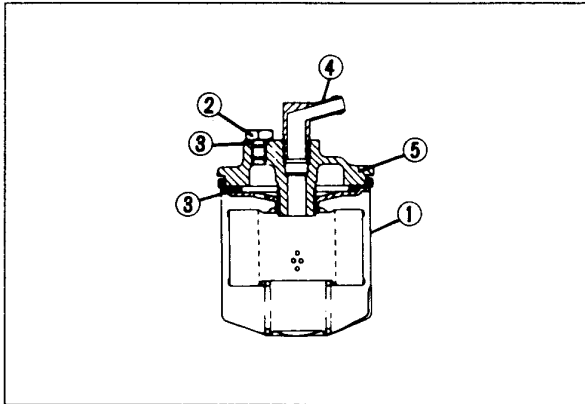

- (1) Fuel filter cartridge
- (2) Air vent plug
- (3) O ring
- (4) Pipe joint
- (5) Cover

## ENGINE OIL



### CAUTION

To avoid personal injury:

- Be sure to stop the engine before checking and changing the engine oil and the oil filter cartridge.
- Do not touch muffler or exhaust pipes while they are hot; Severe burns could result. Always stop the engine and allow it to cool before conducting inspections, maintenance, or for a cleaning procedure.
- Contact with engine oil can damage your skin.  
Put on gloves when using engine oil. If you come in contact with engine oil, wash it off immediately.

#### NOTE:

- Be sure to inspect the engine, locating it on a level place. If placed on gradients accurately, oil quantity may not be measured.

### Checking oil level and adding engine oil

1. Check the engine oil level before starting or more than 5 minutes after stopping the engine.
2. Remove the oil level gauge, wipe it clean and reinstall it.
3. Take the oil level gauge out again, and check the oil level.

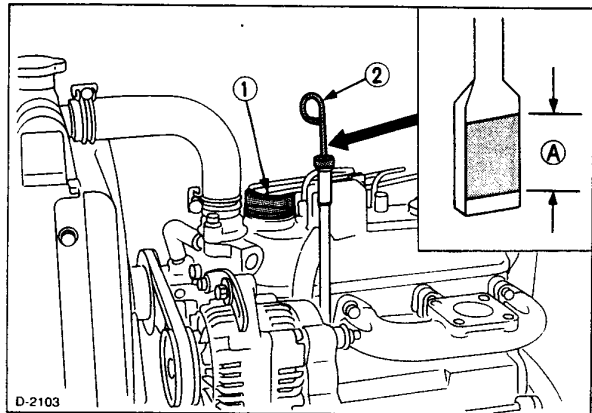

- (1) Oil filler plug
- (2) Oil level gauge
- [Lower end of oil level gauge]
- (A) Engine oil level within this range is proper.

4. If the oil level is too low, remove the oil filler plug, and add new oil to the prescribed level.
5. After adding oil, wait more than 5 minutes and check the oil level again. It takes some time for the oil to drain down to the oil pan.

Engine oil quantity

Model	Quantity
V1205-E, V1305-E, V1505-E	6.0 L (1.59 U.S.gals.)

Oil quantities shown are for standard oil pans.

**IMPORTANT:**

- Engine oil should be MIL-L-2104C or have properties of API classification CD grades or higher.

Change the type of engine oil according to the ambient temperature.

above 25°C (77°F)	SAE30 or SAE10W-30 SAE10W-40
0 to 25°C (32 to 77°F)	SAE20 or SAE10W-30 SAE10W-40
below 0°C (32°F)	SAE10W or SAE10W-30 SAE10W-40

- When using oil of different brands from the previous one, be sure to drain all the previous oil before adding the new engine oil.

■ Changing engine oil



**CAUTION**

To avoid personal injury:

- Be sure to stop the engine before draining engine oil.
- When draining engine oil, place some container underneath the engine and dispose it according to local regulations.
- Do not drain oil after running the engine. Allow engine to cool down sufficiently.

1. Change oil after the initial 50 hours of operation and every 200 hours thereafter.
2. Remove the drain plug at the bottom of the engine, and drain all the old oil. Drain oil will drain easier when the oil is warm.

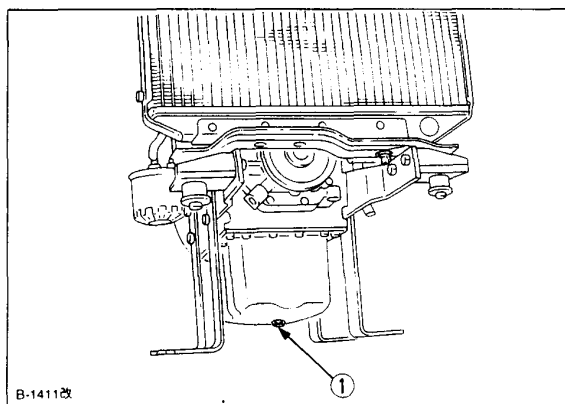

(1) Oil drain plug

3. Add new engine oil up to the upper limit of the oil level gauge.

## ■ Replacing the oil filter cartridge



### CAUTION

To avoid personal injury:

- Be sure to stop the engine before changing the oil filter cartridge.
- Allow engine to cool down sufficiently, oil can be hot and cause burns.

1. Replace the oil filter cartridge every 200 hours of operation.
2. Remove the old oil filter cartridge with a filter wrench.
3. Apply a film of oil to the gasket for the new cartridge.
4. Screw in the cartridge by hand. When the gasket contacts the seal surface, tighten the cartridge enough by hand. Because, if you tighten the cartridge with a wrench, it will be tightened too much.

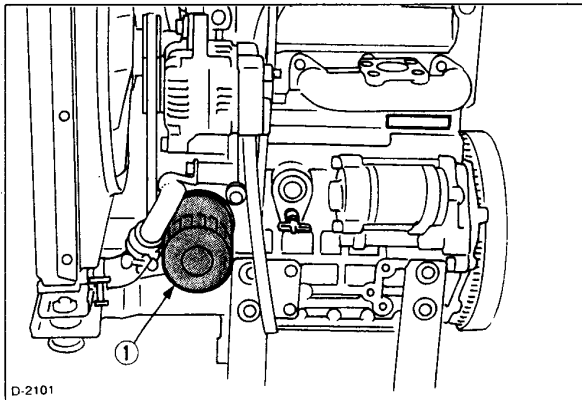

(1) Oil filter cartridge

Remove with a filter wrench

(Tighten with your hand)

5. After the new cartridge has been replaced, the engine oil level normally decreases a little. Thus, run the engine for a while and check for oil leaks through the seal before checking the engine oil level. Add oil if necessary.

### NOTE:

- Wipe off any oil sticking to the machine completely.

## RADIATOR

Coolant will last for one day's work if filled all the way up before operation. Make it a rule to check the coolant level before every operation.



### WARNING

To avoid personal injury:

- Do not stop the engine suddenly, stop it after about 5 minutes of unloaded idling.
- Work only after letting the engine and radiator cool off completely (more than 30 minutes after it has been stopped).
- Do not remove the radiator cap while coolant is hot. When cool to the touch, rotate cap to the first stop to allow excess pressure to escape. Then remove cap completely.

If overheats should occur, steam may gush out from the radiator or reserve tank; Severe burns could result.

**■ Checking coolant level, adding coolant**

1. Remove the radiator cap after the engine has completely cooled, and check to see that coolant reaches the supply port.

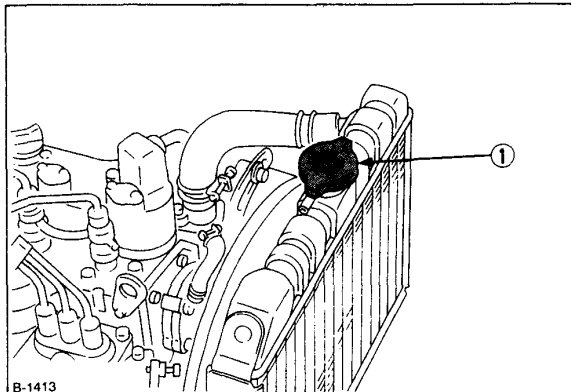

(1) Radiator pressure cap

2. If the radiator is provided with a reserve tank, check the coolant level of the reserve tank. When it is between the "FULL" and "LOW" marks, the coolant will last for one day's work.

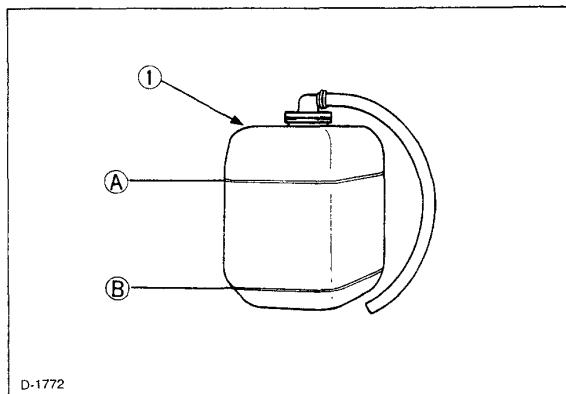

(1) Reserve tank

(A) "FULL"  
(B) "LOW"

3. When the coolant level drops due to evaporation, add water only up to the full level.
4. Check to see that two drain cocks; one is at the crankcase side and the other is at the lower part of the radiator as figures below.

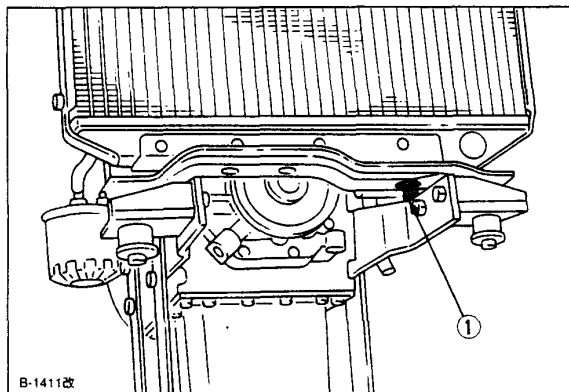
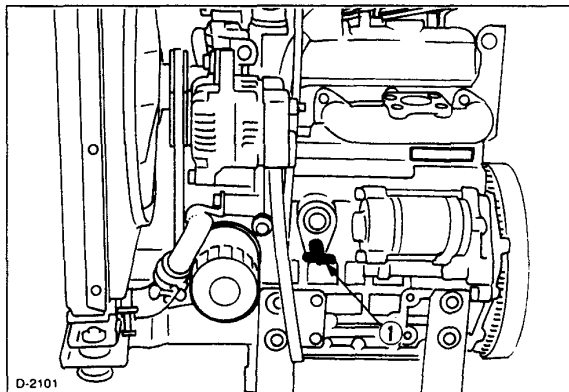

(1) Coolant drain cock

**IMPORTANT:**

- If the radiator cap has to be removed, follow the caution and securely retighten the cap.
- If coolant should be leak, consult your local KUBOTA dealer.
- Make sure that muddy or sea water does not enter the radiator.
- Use clean, fresh water and 50% anti-freeze to fill the recovery tank.
- Do not refill reserve tank with coolant over the "FULL" level mark.
- Be sure to close the radiator cap securely. If the cap is loose or improperly closed, coolant may leak out and decrease quickly.

**■ Changing coolant**

1. To drain coolant, always open both drain cocks and simultaneously open the radiator cap as well. With the radiator cap kept closed, a complete drain of water is impossible.
2. Remove the overflow pipe of the radiator pressure cap to drain the reserve tank.
3. Prescribed coolant volume (U.S.gallons)

Models	Quantity
V1205-E, V1305-E, V1505-E	4.0 L (1.06 U.S.gals.)

**NOTE:**

- Coolant quantities shown are for standard radiators.
4. An improperly tightened radiator cap or a gap between the cap and the seat quickens loss of coolant.
  5. Coolant (Radiator cleaner and anti-freeze)

Season	Coolant
Summer	Pure water and radiator cleaner
Winter (When temperature drops below 0°C (32°F) or all season	Pure water and anti-freeze (See "Anti-freeze" in RADIATOR section)

**■ Remedies for quick decrease of coolant**

1. Check any dust and dirt between the radiator fins and tube. If any, remove them from the fins and the tube.
2. Check the tightness of the fan belt. If loose, tighten it securely.
3. Check the internal blockage in the radiator hose. If scale forms in the hose, clean with the scale inhibitor or its equivalent.

**■ Checking radiator hoses and clamp**



**CAUTION**

To avoid personal injury:

- Be sure to check radiator hoses and hose clamps periodically. If radiator hose is damaged or coolant leaks, overheats or severe burns could occur.

Check to see if radiator hoses are properly fixed every 200 hours of operation or 6 months, whichever comes first.

1. If hose clamps are loose or water leaks, tighten hose clamps securely.
2. Replace hoses and tighten hose clamps securely, if radiator hoses are swollen, hardened or cracked.

Replace hoses and hose clamps every 2 years, or earlier, if checked and found that hoses are swollen, hardened or cracked.

**■ Precaution at overheating**

Take the following actions in the event the coolant temperature is nearly or more than the boiling point, what is called "Overheating". Take these actions if the engine's alarm buzzer sounds or the alarm lamp lights up.

1. Stop the engine operation in a safe place and keep the engine unloaded idling.
2. Do not stop the engine suddenly. Stop it after about 5 minutes of unloaded idling.
3. If the engine stalls within about 5 minutes of running under no load, immediately leave and keep yourself away from the machine. Do not open the hood and any other part.
4. Keep yourself and others well away from the engine for further 10 minutes or while the steam blown out.
5. Checking that there gets no danger such as burn, get rid of the causes of overheating according to the manual, see "TROUBLESHOOTING" section. And then, start again the engine.

**■ Cleaning radiator core (outside)**

If dust is between the fin and tube, wash it away with running water.

**IMPORTANT:**

- Do not clean radiator with firm tools such as spatulas or screwdrivers. They may damage specified fin or tube. It can cause coolant leaks or decrease coolings performance.

## ■ Anti-freeze



### CAUTION

To avoid personal injury:

- When using anti-freeze, put on some protection such as rubber gloves.
- If should drink anti-freeze, throw up at once and take medical attention.
- When anti-freeze comes in contact with the skin or clothing, wash it off immediately.
- Do not mix different types of anti-freeze.
- Keep fire and children away from anti-freeze.
- Be mindful of the environment and ecology. Before draining any fluids, find out the correct way of disposing by checking with local codes.
- Also, observe the relevant environmental protection regulations when disposing of oil, fuel, coolant, brake fluid, filters and batteries.

If it freezes, coolant can damage the cylinders and radiator. It is necessary, if the ambient temperature falls below 0°C (32°F), to remove coolant after operating or to add anti-freeze to it.

1. There are two types of anti-freeze available; use the permanent type (PT) for this engine.
2. Before adding anti-freeze for the first time, clean the radiator and engine interior by pouring fresh water, and draining it a few times.
3. The procedure for the mixing of water and anti-freeze differs according to the make of the anti-freeze and the ambient temperature. Refer to SAE J1034 standard, more specifically also to SAE J814c.
4. Mix the anti-freeze with water, and then fill into the radiator.

### IMPORTANT:

- When the anti-freeze is mixed with water, the anti-freeze mixing ratio must be less than 50%.

Vol % Anti-freeze	Freezing Point		Boiling Point ※	
	°C	°F	°C	°F
40	-24	-12	106	222
50	-37	-34	108	226

※ At  $1.013 \times 10^5$  Pa (760mmHg) pressure (atmospheric). A higher boiling point is obtained by using a radiator pressure cap which permits the development of pressure within the cooling system.

### NOTE:

- The above data represents industry standards that necessitate a minimum glycol content in the concentrated anti-freeze.
- When the coolant level drops due to evaporation, add water only to keep the anti-freeze mixing ratio less than 50%. In case of leakage, add anti-freeze and water in the specified mixing ratio before filling into the radiator.
- Anti-freeze absorbs moisture. Keep unused anti-freeze in a tightly sealed container.
- Do not use radiator cleaning agents when anti-freeze has been added to the coolant. (Anti-freeze contains an anti-corrosive agent, which will react with the radiator cleaning agent forming sludge which will affect the engine parts.)

## ■ Radiator cement

As the radiator is solidly constructed, there is little possibility of water leakage. Should this happen, however, radiator cement can easily fix it. If leakage is serious, contact your local KUBOTA dealer.



## AIR CLEANER

Since the air cleaner employed on this engine is a dry type, never apply oil to it.

1. Open the evacuator valve once a week under ordinary conditions — or daily when used in a dusty place. This will get rid of large particles of dust and dirt.
2. Wipe the inside air cleaner clean with cloth if it is dirty or wet.
3. Avoid touching the element except when cleaning.
4. When dry dust adheres to the element, blow compressed air from the inside turning the element. Pressure of compressed air must be under 686kPa (7kgf/cm<sup>2</sup>, 99psi).
5. When carbon or oil adheres to the element, soak the element in detergent for 15 minutes, then wash it several times in water, rinse with clean water and dry it naturally.
6. After the element is fully dried, inspect the inside of the element with a light, and check if it is damaged or not. (referring to the instructions on the label attached to the element.)
7. Replace the element every year or every 6 cleanings.

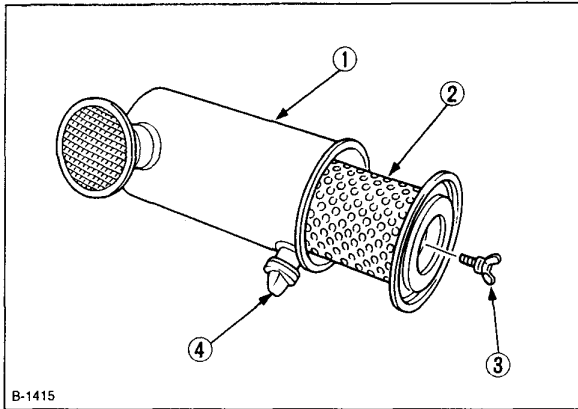

B-1415

- (1) Air cleaner body
- (2) Element
- (3) Wing bolt
- (4) Evacuator valve

### IMPORTANT:

- Make sure the wing bolt for the element is tight enough. If it is loose, dust and dirt may be sucked in, wearing down the cylinder liner and piston ring earlier, and thereby resulting in poor power output.
- Do not overservice the air cleaner element. Overservicing may cause dirt to enter the engine causing premature wear. Use the dust indicator as a guide on when to service.

### ■ Evacuator valve

Open the evacuator valve once a week under ordinary conditions - or daily when used in a dusty place - to get rid of large particles of dust and dirt.

### ■ Dust indicator (optional)

If the red signal on the dust indicator attached to the air cleaner is visible, the air cleaner has reached the service level.

Clean the element immediately, and reset the signal with the "RESET" button.

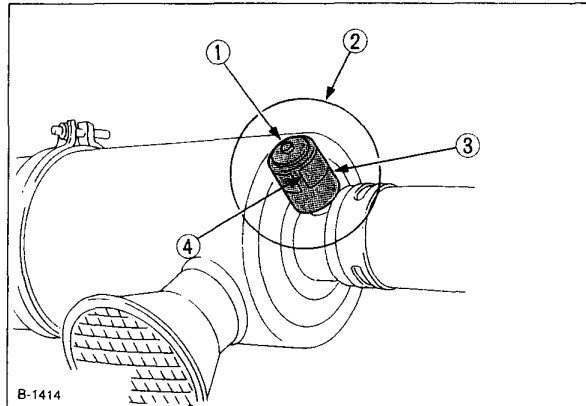

B-1414

- (1) "RESET" button
- (2) Dust indicator
- (3) Service level
- (4) Signal

### ■ For the air cleaner with a dust cup (optional)

Remove and clean out the dust cup before it becomes half full with dust; usually once a week, or even every day if the working surroundings are dusty.

Install the air cleaner dust cup with "TOP" indicated on the rear of the cup in the up position. (However, it may be installed in either direction when the cover is placed at the lower part.)

#### IMPORTANT:

- If the dust cup is mounted incorrectly, dust or dirt does not collect in the cup, and direct attachment of the dust to the element will cause its lifetime to shorten to a great extent.

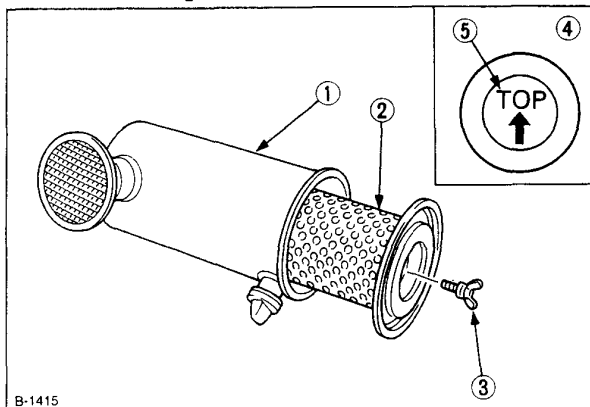

- (1) Air cleaner body  
 (2) Element  
 (3) Wing bolt  
 (4) Dust cup  
 (5) "TOP" mark

## BATTERY

Mishandling of the battery shortens the service life and adds to maintenance costs. Obtain the maximum performance and the longest life of the battery by handling properly and with care.



#### CAUTION

To avoid personal injury:

- Be careful not to let the battery electrolyte contact your body or clothing.
- Wear eye protection and rubber gloves, since the diluted sulfuric acid solution burns skin and eats holes in clothing. Should this occur, immediately wash it off with running water and get medical attention.

Engine starting will be more difficult, if the battery charge is low. Be careful to recharge it at an early occasion before it is too late.

### ■ Battery charging



#### DANGER

The battery comes in two types: Refillable, Non-refillable.

- For using the refillable type battery, follow the instructions below. Do not use or charge the battery if its fluid level stands below the LOWER (lower limit level) mark. Otherwise, the battery component parts may deteriorate earlier than expected, which may shorten the battery's service life or cause an explosion. Immediately, add distilled water until the battery's fluid level is between the UPPER and LOWER levels.



#### CAUTION

To avoid personal injury:

- When the battery is being activated, hydrogen and oxygen gases in the battery are extremely explosive. Keep open sparks and flames away from the battery at all times, especially when charging the battery.
- When charging the battery, remove the battery vent plugs.
- When disconnecting the cable from the battery, start with the negative terminal, and when connecting them, start with the positive terminal first.
- DO NOT check the battery charge by placing a metal object across the terminals. Use a voltmeter or hydrometer.

1. Make sure each electrolyte level is to the bottom of vent wells, if necessary, add only distilled water in a well-ventilated place.

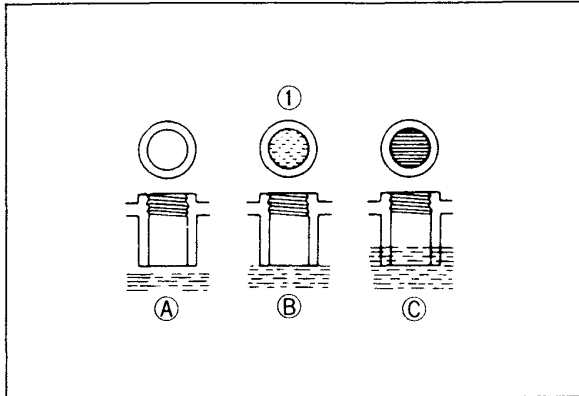

(1) Battery electrolyte level (A) "TOO LOW"  
(B) "PROPER"  
(C) "TOO HIGH"

2. To slow charge the battery, connect the charger positive terminal to the battery positive terminal, and the negative to the negative, then recharge in the standard fashion.
3. Quick recharging charges the battery at a high rate in a short time. This is only for emergencies.
4. Recharge the battery as early as possible, or battery life will be extremely shortened.
5. When exchanging an old battery for a new one, use a battery of equal specifications shown in page 26, 27.

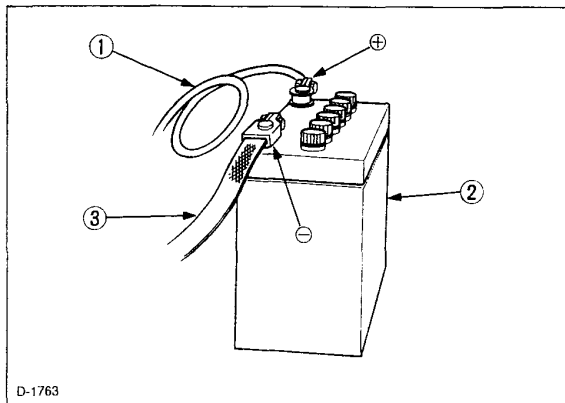

(1) Thick cable red (+)  
(2) Battery case  
(3) Earth cable black (-)

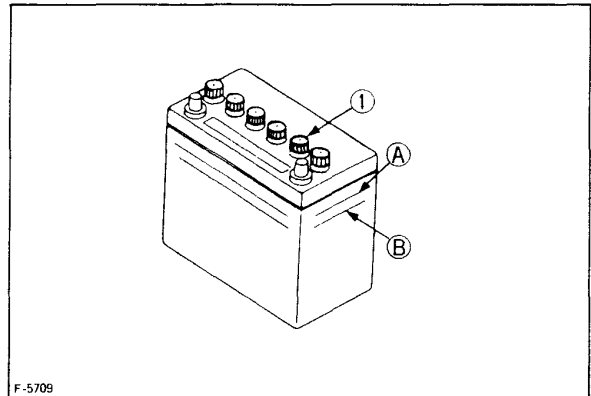

(1) Plug (A) "HIGHEST LEVEL"  
(B) "LOWEST LEVEL"

**IMPORTANT:**

- Connect the charger positive terminal to the battery positive terminal, and negative to the negative.
- When disconnecting the cable from the battery, start with the negative terminal first. When connecting the cable to the battery, start with the positive terminal first. If reversed, the contact of tools on the battery may cause a short.

**Direction for long term storage**

1. When storing the engine for long periods of time, remove the battery, adjust the electrolyte to the proper level, and store in a dry and dark place.
2. The battery naturally discharges while it is stored. Recharge it once a month in summer, and every 2 months in winter.

## ELECTRIC WIRING



### CAUTION

To avoid personal injury:

Shorting of electric cable or wiring may cause a fire.

- Check to see if electric cables and wiring are swollen, hardened or cracked.
  - Keep dust and water away from all power connections.
- Loose wiring terminal parts, make bad connections. Be sure to repair them before starting the engine.

Damaged wiring reduces the capacity of electrical parts. Change or repair damaged wiring immediately.

## FAN BELT

### ■ Adjusting Fan Belt Tension



### CAUTION

To avoid personal injury:

- Be sure to stop the engine and remove the key before checking the belt tension.
- Be sure to reinstall the detached safety shield after maintenance or checking.

Proper fan belt tension

A deflection of between 7 to 9 mm (0.28 to 0.35 in.) when the belt is pressed in the middle of the span.

1. Stop the engine and remove the key.
2. Apply moderate thumb pressure to belt between pulleys.
3. If tension is incorrect, loosen the alternator mounting bolts and, using a lever placed between the alternator and the engine block, pull the alternator out until the deflection of the belt falls within acceptable limits.
4. Replace fan belt if it is damaged.

### IMPORTANT:

- If belt is loosen or damaged and the fan is damaged, it could result in overheats or insufficient charging. Correct or replace belt.

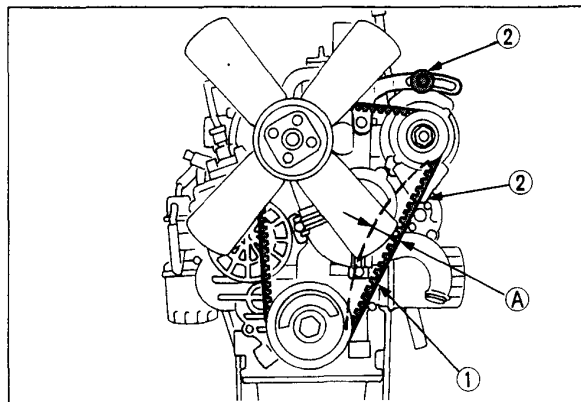

(1) Fan belt

(2) Bolt and nut

(A) 7 to 9 mm (0.28 to 0.35 in.)

(under load of 10 kgf (22.1 lbs))

# CARRIAGE AND STORAGE

## CARRIAGE



### CAUTION

To avoid personal injury:

- Fix the engine securely not to fall during operation.
- Do not stand near or under the engine while carrying it.
- The engine is heavy. In handling it, be very alert not to get your hands and body caught in.

1. Use carrier such as crane when carrying the engine, or hurt your waist and yourself. Support the engine securely with rope not to fall while carrying it.
2. When lifting the engine, put the hook securely to metal fittings attached to the engine. Use strong hook and fittings enough to hang the engine.

## STORAGE



### CAUTION

To avoid personal injury:

- Do not clean the machine with engine running.
- To avoid the danger of exhaust fume poisoning, do not operate the engine in a closed building without proper ventilation.
- When storing the engine just after running, let the engine cool off.

Before storing the engine for more than a few months, remove any dirt on the machine, and:

1. Drain the coolant in the radiator. Open the cock at the bottom of the radiator, and remove the pressure cap to drain water completely. Leave the cock open. Hang a note written "No water" on the pressure cap. Since water may freeze when the temperature drops below 0°C (32°F), it is very important that no water is left in the machine.
2. Remove dirty engine oil, fill with new oil and run the engine for about 5 minutes to let the oil penetrate to all the parts.
3. Check all the bolts and nuts, and tighten if necessary.
4. Remove the battery from the engine, adjust the electrolyte level, and recharge it. Store the battery in a dry and dark place.
5. When the engine is not used for a long period of time, run it for about 5 minutes under no load every 2-3 months to keep it free from rust. If the engine is stored without any running, moisture in the air may condense into dew over the sliding parts of the engine, resulting in rust there.
6. If you forget to run the engine for longer than 5-6 months, apply enough engine oil to the valve guide and valve stem seal and make sure the valve works smoothly before starting the engine.
7. Store the engine in a flat place and remove the key from engine.
8. Do not store the engine in a place where has flammable materials such as dry grass or straw.
9. When covering the engine for storage, let engine and muffler cool off completely.
10. Operate the engine after checking and repairing damaged wirings or pipes, and clearing flammable materials carried by mouse.

# TROUBLESHOOTING

If the engine does not function properly, use the following chart to identify and correct the cause.

## ■ When it is difficult to start the engine.

Cause	Countermeasures
Fuel is thick and doesn't flow.	<ul style="list-style-type: none"> <li>* Check the fuel tank and fuel filter. Remove water, dirt and other impurities.</li> <li>* As all fuel will be filtered by the filter, if there should be water or other foreign matters on the filter, clean the filter with kerosene.</li> </ul>
Air or water mixed in fuel sistem	<ul style="list-style-type: none"> <li>* If air is in the fuel filter or injection lines, the fuel pump will not work properly. To attain proper fuel injection pressure, check carefully for loosened fuel line coupling, loose cap nut, etc.</li> <li>* Loosen joint bolt atop fuel filter and air vent screws of fuel injection pump to eliminate all the air in the fuel system.</li> </ul>
Thick carbon deposits on orifice of injection nozzle.	<ul style="list-style-type: none"> <li>* This is caused when water or dirt is mixed in the fuel. Clean the nozzle injection piece, being careful not to damage the orifice.</li> <li>* Check to see if nozzle is working properly or not. If not, install a new nozzle.</li> </ul>
Valve clearance is wrong.	* Adjust valve clearance to 0.145 to 0.185 mm (0.0057 to 0.0072 in.) when the engine is cold.
Leaking valves	* Grind valves.
Fuel injection timing is wrong.	<ul style="list-style-type: none"> <li>* Adjust injection timing</li> <li>* The injection timing 0.3 rad (18°) before top dead center.</li> </ul>
Engine oil becomes thick in cold weather and engine cranks slow.	* Change grade of oil according to the weater (temperature.)
Low compression	<ul style="list-style-type: none"> <li>* Bad valve or excessive wear of rings, pistons and liners cause insufficient compression. Replace with new parts.</li> </ul>
Battery is discharged and the engine will not crank.	<ul style="list-style-type: none"> <li>* Charge battery.</li> <li>* In winter, always remove battery from machine, charge fully and keep indoors. Install in machine at time of use.</li> </ul>

## ■ When output is insufficient

Cause	Countermeasures
Carbon stuck around orifice of nozzle piece	<ul style="list-style-type: none"> <li>* Clean orifice and needle valve, being very careful not to damage the nozzle orifice.</li> <li>* Check nozzle to see if good. If not, replace with new parts.</li> </ul>
Compression is insufficient. Leaking valves	<ul style="list-style-type: none"> <li>* Bad valve and excessive wear of rings, pistons and liners cause insufficient compression. Replace with new parts.</li> <li>* Grind valves.</li> </ul>
Fuel is insufficient.	* Check fuel system.
Overheating of moving parts	<ul style="list-style-type: none"> <li>* Check lubricating oil system.</li> <li>* Check to see if lubricating oil filter is working properly.</li> <li>* Filter element deposited with impurities would cause poor lubrication. Change element.</li> <li>* Check the clearance of bearing are within factory specs.</li> <li>* Check injection timing.</li> </ul>
Valve clearance is wrong.	* Adjust to proper valve clearance of 0.145 to 0.185 mm (0.0057 to 0.0072 in.) with engine cold.
Air cleaner is dirty	* Clean the element every 100 hours of operation.
Fuel injection pressure is wrong.	* Adjust to proper pressure. 13.7 Mpa (140kgf/cm <sup>2</sup> , 1991psi)
Injection pump wear	<ul style="list-style-type: none"> <li>* Do not use poor quality fuel as it will cause wear of the pump. Only use No.2-D diesel fuel.</li> <li>* Check the fuel injection pump element and delivery valve assembly and replace as necessary.</li> </ul>

### NOTE:

- If the cause of trouble can not be found, contact your KUBOTA dealer.

### ■ When engine suddenly stops

Cause	Countermeasures
Lack of fuel	* Check the fuel tank and refill the fuel, if necessary. * Also check the fuel system for air or leaks.
Bad nozzle	* If necessary, replace with a new nozzle.
Moving parts are overheated due to shortage of lubrication oil or improper lubrication.	* Check amount of engine oil with oil level gauge. * Check lubricating oil system. * At every 2 times of oil change, oil filter cartridge should be replaced. * Check to see if the engine bearing clearances is within factory specs.

#### NOTE:

- When the engine has suddenly stopped, decompress the engine by the decomp and turn the engine lightly by pulling on the fan belt. If the engine turns easily without abnormalities, the cause of the trouble is usually lack of fuel or bad nozzle.

### ■ When color of exhaust is especially bad

Cause	Countermeasures
Fuel governing device bad	* Contact dealer for repairs.
Fuel is of extremely poor is quality.	* Select good quality fuel Use No. 2-D diesel fuel only.
Nozzle is bad.	* If necessary, replace with new nozzle.
Combustion is incomplete.	* Cause is poor atomization, improper injection timing, etc. Because of trouble in injection system or in poor valve adjustment, or compression leakage, poor compression, etc. Check for the cause.

### ■ When engine must be stopped immediately

Cause	Countermeasures
Engine revolution suddenly decreases or increases.	* Check the adjustments, injection timing and the fuel system.
Unusual sound is heard suddenly.	* Check all moving parts carefully.
Color of exhaust suddenly turns dark.	* Check the fuel injection system, especially the fuel injection nozzle.
Bearing parts are overheated.	* Check the lubricating system.
Oil lamp lights up during operation.	* Check lubricating system. * Check , if the engine bearing clearances are within factory specs. * Check the function of the relieve valve in the lubricating system. * Check pressure switch. * Check filter base gasket.

### ■ When engine overheats

Cause	Countermeasures
Engine oil insufficient	* Check oil level. Replenish oil as required.
Fan belt broken or elongated	* Change belt or adjust belt tension.
Coolant insufficient	* Replenish coolant.
Excessive concentration of antifreeze	* Add water only or change to coolant with the specified mixing ratio.
Radiator net or radiator fin clogged with dust	* Clean net or fin carefully.
Inside of radiator or coolant flow route corroded	* Clean or replace radiator and parts.
Fan or radiator or radiator cap defective	* Replace defective part.
Thermostat defective	* Check thermostat and replace if necessary.
Temperature gauge or sensor defective	* Check temperature with thermometer and replace if necessary.
Overload running	* Reduce load.
Head gasket defective or water leakage	* Replace parts.
Incorrect injection timing	* Adjust to proper timing.
Unsuitable fuel used	* Use the specified fuel.

# SPECIFICATIONS

			V1505-E	
Vertical, water-cooled, 4-cycle diesel engine				
4				
			74×78.4 (3.07×3.09)	
			1498 (91.41)	
Spherical Type (E-TVCS)				
			25.0/3000 (33.5/3000)	
			21.6/3000 (29.0/3000)	
3200				
800~900				
1-3-4-2				
Counter-clockwise (viewed from flywheel side)				
Bosch MD Type Mini Pump				
13,73 MPa (140kgf/cm <sup>2</sup> , 1991 psi)				
				19°
			23 : 1	
Diesel Fuel No.2-D (ASTM D975)				
above CD grade				
			591.3×396×613.7 (23.28×15.59×24.16)	
			110 (242.5)	
Cell starter (with glow plug)				
12 V, 1.2 kW				
12V, 360 W				
12V, 70AH, equivalent				



**PAGE LEFT BLANK**

# WIRING DIAGRAMS

KTC/SAE standard  
(Energize to run)

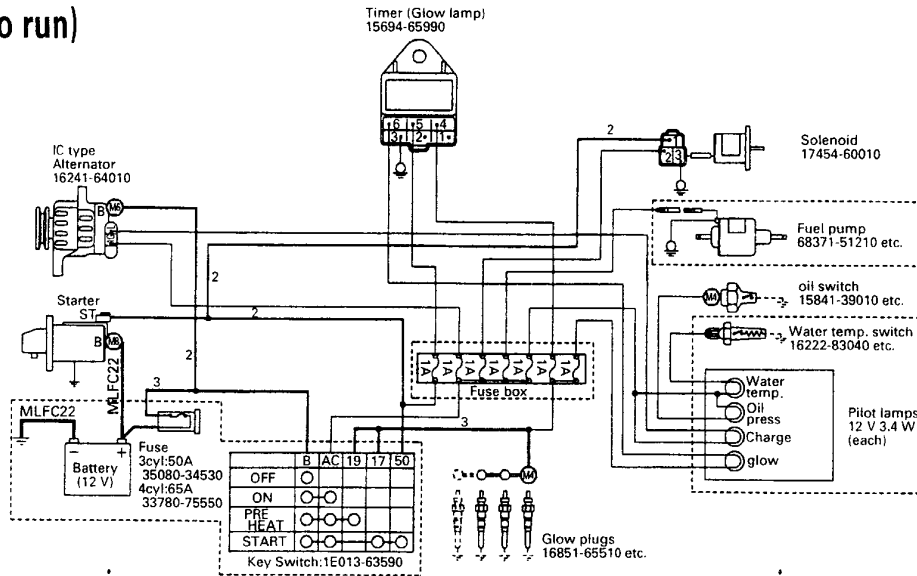

- ★ The parts boxed in [ ] are reference, NOT equipped for standard engine spec.
- ★ Non marked wire dia. is 0.8~1.25 mm<sup>2</sup>.

**PAGE LEFT BLANK**

# WARRANTY RETURN GOODS POLICY

## LIMITED WARRANTY

The Manufacturer warrants its products to be free from defects in material and workmanship for a period of twelve months from the date of shipment from the factory. The Manufacturer shall not be responsible for any damage resulting to or caused by its products by reason of installation, improper storage, unauthorized service, alteration of the products, neglect or abuse, or use of the product in a manner inconsistent with its design. The warranty does not extend to any component parts not manufactured by Manufacturer; however, Manufacturer's warranty herein shall not limit any warranties made by manufacturers of component parts which extend to Buyer.

Claims for defects in material and workmanship shall be made in writing to Manufacturer within ten days of discovery of defect. Manufacturer may either send a service representative or have the product returned to its factory at Buyer's expense for inspection. Upon notification of defect, Manufacturer will issue a return goods authorization number to Buyer. The return goods authorization number must accompany the product returned. If judged by the Manufacturer to be defective in material or workmanship, the product will be replaced or repaired at the option of the Manufacturer, free from all charges except authorized transportation. Buyer shall be responsible for all maintenance services consisting of lubrication and cleaning of equipment, replacing expandable parts, making minor adjustments, and performing operating checks, all in accordance with procedures outlined in Manufacturer's maintenance literature.

THE FOREGOING WARRANTY IS IN LIEU OF ALL OTHER WARRANTIES AND NO REPRESENTATIONS, GUARANTEES, OR WARRANTIES, EXPRESS OR IMPLIED, (INCLUDING BUT NOT LIMITED TO A WARRANTY OF MERCHANTABILITY OR FITNESS FOR A PARTICULAR PURPOSE), ARE MADE BY THE MANUFACTURER IN CONNECTION WITH THE MANUFACTURE OR SALE OF ITS PRODUCTS. NO EMPLOYEE, DISTRIBUTOR, OR REPRESENTATIVE IS AUTHORIZED TO CHANGE THIS WARRANTY ON BEHALF OF MANUFACTURER. THE REMEDIES OF BUYER SET FORTH HEREIN ARE EXCLUSIVE AND ARE IN LIEU OF ALL OTHER REMEDIES. THE LIABILITY OF MANUFACTURER WHETHER IN CONTRACT, TORT, UNDER ANY WARRANTY, OR OTHERWISE SHALL NOT EXTEND BEYOND ITS OBLIGATION TO REPAIR OR REPLACE, AT ITS OPTION ANY PRODUCT OR PART FOUND BY MANUFACTURER TO BE DEFECTIVE IN MATERIAL OR WORKMANSHIP. MANUFACTURER SHALL NOT BE LIABLE FOR COST OF INSTALLATION AND/OR REMOVAL OR BE RESPONSIBLE FOR DIRECT, INDIRECT, SPECIAL OR CONSEQUENTIAL DAMAGES OF ANY NATURE.

## GENERAL RETURNS OF MERCHANDISE

1. All returns must be pre-authorized
  - A. Please call our parts department for an RGA number
  - B. Please include RGA number on the outside of box
  - C. Include any required paper work or special instructions
  - D. Items returned without an RGA number will not be accepted
2. All returns are subject to a 20% restock charge.
3. Special items are non-returnable
  - A. Non-stock parts
  - B. Custom parts
  - C. If you are unsure about a parts status when ordering, ask your McLaughlin representative if the item fits on of the above conditions.
4. Items must be returned within thirty days of original order date.
5. Items not returned within 30 days from the date of RGA is issued will not be accepted.
6. The item(s) must be in new condition. Used item(s) are not returnable.



# Notes

A large rectangular box with a black border, containing 30 horizontal lines for writing notes. The lines are evenly spaced and extend across the width of the box.