



Providing Solutions Since 1921

2006 Perimeter Road. Greenville, SC 29605

Toll Free: 800/435-9340 – Phone: 864/277-5870

Fax: 864/235-9661 – Website address: www.mclaughlinunderground

Email address: mmole@mightymole.com

PARTS MANUAL

VX30-250

VSK30-250

E850250

SERIAL NUMBER – V25S0411161887 TO PRESENT

5/31/2016

2016 by McLaughlin Group, Inc.

All rights reserved. No part of this manual may be reproduced in any form, or by any means without prior written permission of McLaughlin Group, Inc.

Table of Contents

DECAL LAYOUT	5
TRAILER ASSEMBLY.....	10
SKID ASSEMBLY.....	12
WATER REEL ASSEMBLY	14
WATER TANK ASSEMBLY 50 GAL.....	22
WATER TANK ASSEMBLY 100 GAL	24
HYDRAULIC PUMP ASSEMBLY.....	26
ENCLOSURE ASSEMBLY	30
CONTROL PANEL ASSEMBLY	34
ELECTRICAL BRACKET ASSEMBLY	36
ENGINE ASSEMBLY	38
BLOWER ASSEMBLY	40
WATER PUMP ASSEMBLY.....	44
ANTIFREEZE ASSEMBLY.....	50
SPOIL TANK ASSEMBLY.....	52
FILTRATION ASSEMBLY	54
TOOL RACK ASSEMBLY	56
HOSE ASSEMBLY	58
SUCTION TOOL ASSEMBLY	60
REDUCTION TOOL ASSEMBLY	62
WASH WAND TOOL ASSEMBLY	64
ROTARY LANCE TOOL ASSEMBLY.....	66
VALVE BOX TOOL ASSEMBLY.....	68
LAWN SWEEPER TOOL ASSEMBLY.....	70
ARROWBOARD OPTION ASSEMBLY.....	72
STRONGARM OPTION ASSEMBLY.....	74
REMOTE DRAIN OPTION ASSEMBLY.....	76
VACUUM DIESEL ENG. SCHEMATIC	79
ROOT BLOWER MANUAL	84

PAGE LEFT BLANK

DECAL LAYOUT



WARNING

Read manual.
Death or serious injury may result.
Read and understand
all safety and operating instructions
BEFORE operating any equipment.

J200420

Part #: J200420

INSTRUCTIONS

DUMP PROCEDURE MANUAL DOOR

1. Open gate valve - drain liquid - close gate valve
2. Remove inlet port plug
3. Click FULL TANK OVERRIDE switch to ON position - Start engine
4. Install inlet port plug to build vacuum
5. Unlock tank door
6. DO NOT STAND AT REAR OF UNIT - shut off engine
7. Wait for vacuum to release the door - start engine
8. Hold TANK RAISE switch up to raise tank
9. After dumping, hold TANK LOWER switch down to lower tank
10. Lock tank door

J200466

Part #: J200466

INSTRUCTIONS

START PROCEDURE

1. Fill water tank
2. Open ball valve - prime water pump
3. Remove port plug from inlet port
4. Preheat engine - (cold start) 15 seconds
5. Depress murphy switch - start engine
6. When light goes out release murphy switch

©2004 Hazard Communication Systems, LLC 800-748-0241 www.safetylabel.com 04134 Recorder No. J200468

Part #: J200468

WARNING

Electricity, or Gas
Explosion Can Kill

Locate Utilities
Call 811

No. J200210

Part #: J200210



WARNING

Moving parts.
Death or serious injury
may result.
Stop engine
before servicing.

J200425

Part #: J200425

WARNING

ENTANGLEMENT HAZARD
Rotating pulleys and belts
could cause serious injury.
Do not operate
without guards in place.

J200445

Part #: J200445

DECAL LAYOUT



⚠ WARNING	
	HIGH PRESSURE WATER Pressure wand can cause serious injury. Keep hands and feet away. Wear protective clothing.

Part #: J200450

	⚠ WARNING
	CRUSHING WEIGHT DEATH OR SERIOUS INJURY COULD RESULT EMPTY TANK BEFORE SERVICING ALWAYS INSTALL SAFETY BAR WHEN WORKING ON RAISED TANK J200458

Part #: J200458

⚠ DANGER

SUFFOCATION HAZARD. Vacuum hoses will cause death or serious injury. Keep hoses and tools away from face and body.

J200415

Part #:

	⚠ WARNING
	Pinch point. Serious injury may result. Keep hands clear when closing door or lowering tank.

Part #: J200455

Two decals required for rear door

Part #: J200455

	⚠ WARNING
	Pinch point. Serious injury may result. Keep hands clear when closing door or lowering tank.

J200455



Vermeer



Part #: J200174

	⚠ WARNING
	FIRE OR EXPLOSION POSSIBLE. Do not vacuum flammable or combustible substances.

Part #: J200473

INSTRUCTIONS
DUMP PROCEDURE MANUAL DOOR
1. Open gate valve - drain liquid - close gate valve 2. Remove inlet port plug 3. Click FULL TANK OVERRIDE switch to ON position - Start engine 4. Install inlet port plug to build vacuum 5. Unlock tank door 6. DO NOT STAND AT REAR OF UNIT - shut off engine 7. Wait for vacuum to release the door - start engine 8. Hold TANK RAISE switch up to raise tank 9. After dumping, hold TANK LOWER switch down to lower tank 10. Lock tank door

Part #: J200466

⚠ DANGER	
	Crushing weight. Spoil and door will cause death or serious injury. Unlock door only under vacuum. Stay away from door when dumping.

Part #: J200410

PAGE LEFT BLANK

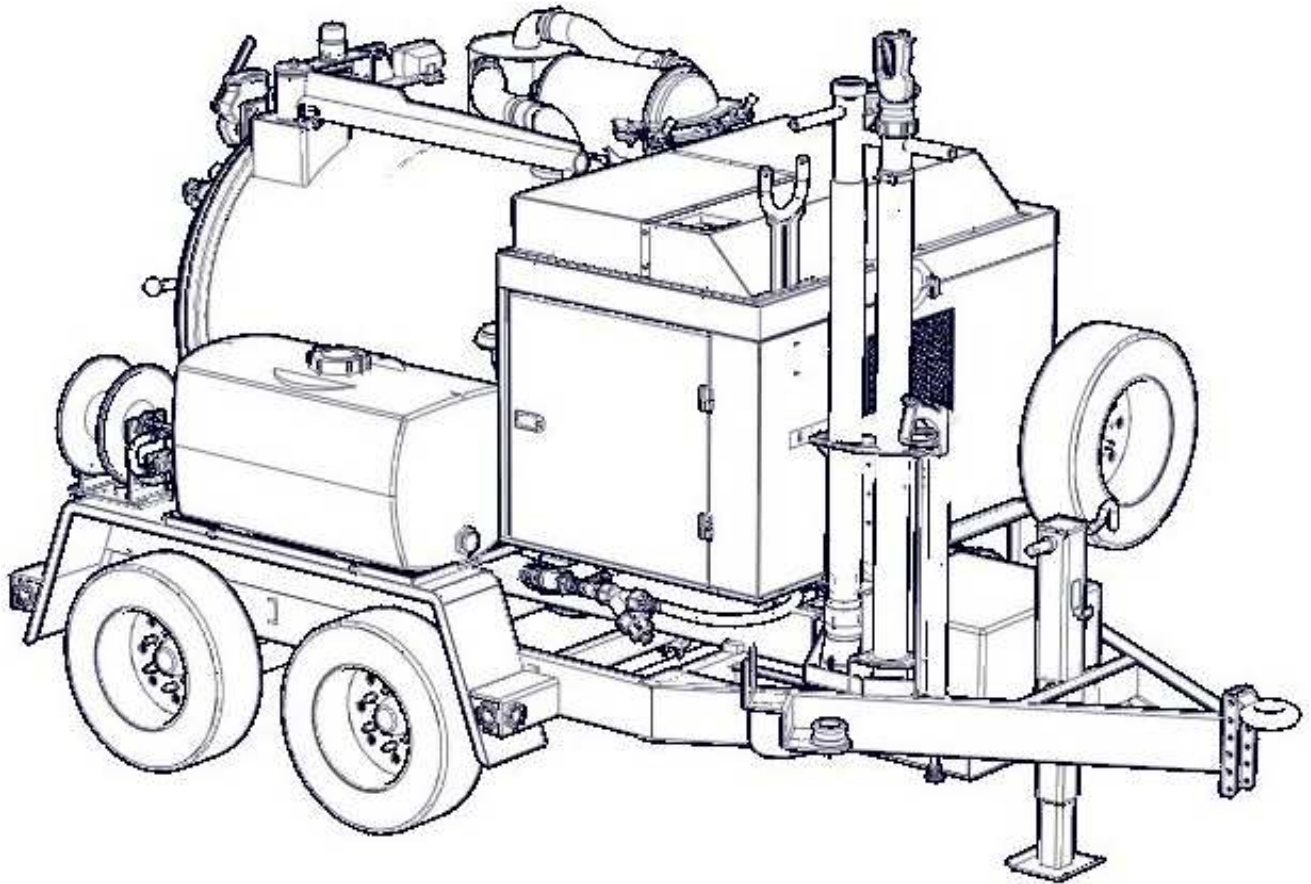

PAGE LEFT BLANK

VX30-250 TRAILER

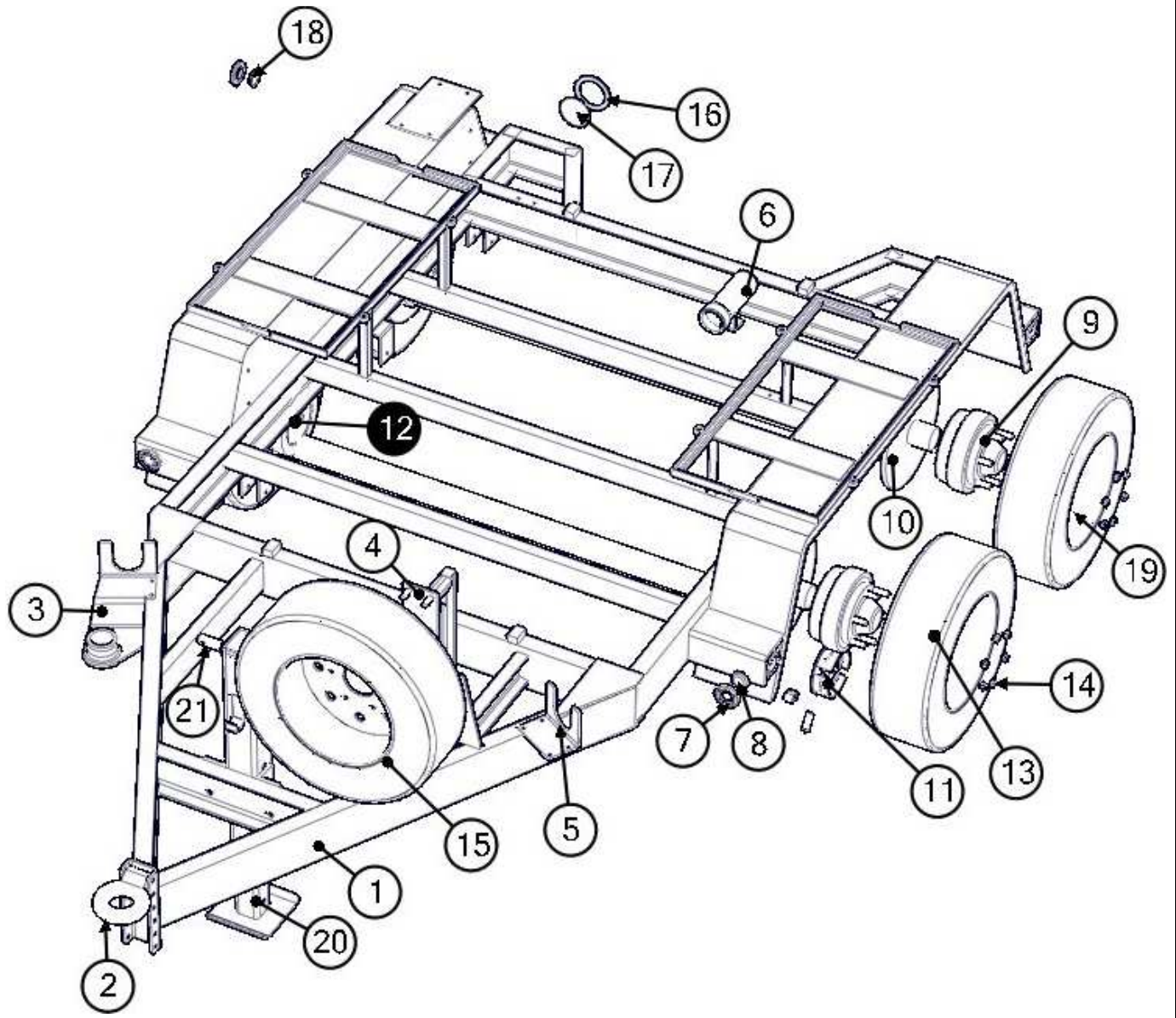

VX30-250 TRAILER

BOM ID	Qty	Name
1	1	8040680 TRAILER, VX30-250
2	1	8043980 PINTLE EYE
3	1	8048768 HOSE STORAGE BRACKET (STRONG ARM)
4	1	8091745 RACK, SPARE TIRE (OPTIONAL)
5	1	8040940 BRACKET, HOSE STORAGE V250
6	1	8047856 EXHAUST BRACKET WELDMENT
7	8	8091469 GROMMET, LIGHT 2in RUBBER
8	4	8091468 LIGHT, TRAILER 2" LED AMBER
9	4	8047035 HUB, 6 LUG
10	2	8045897 AXLE
11	2	8046307 LH BRAKE ASSEMBLY
12	2	8046308 RH BRAKE ASSEMBLY
13	4	8046530 TIRE, ST225_75R15
14	24	8043987 LUG NUT
15	1	8092105 TIRE AND WHEEL ASSEMBLY VX250
16	2	8044003 4in RUBBER GROMMET
17	2	8044001 4in STOP_TURN LIGHT
18	4	8091370 LIGHT, TRAILER 2" LED RED
19	4	8046531 WHEEL, R15 X 6
20	1	8043548 JACK, MANUAL
21	1	8043984 HANDLE, JACK

SKID ASSEMBLY

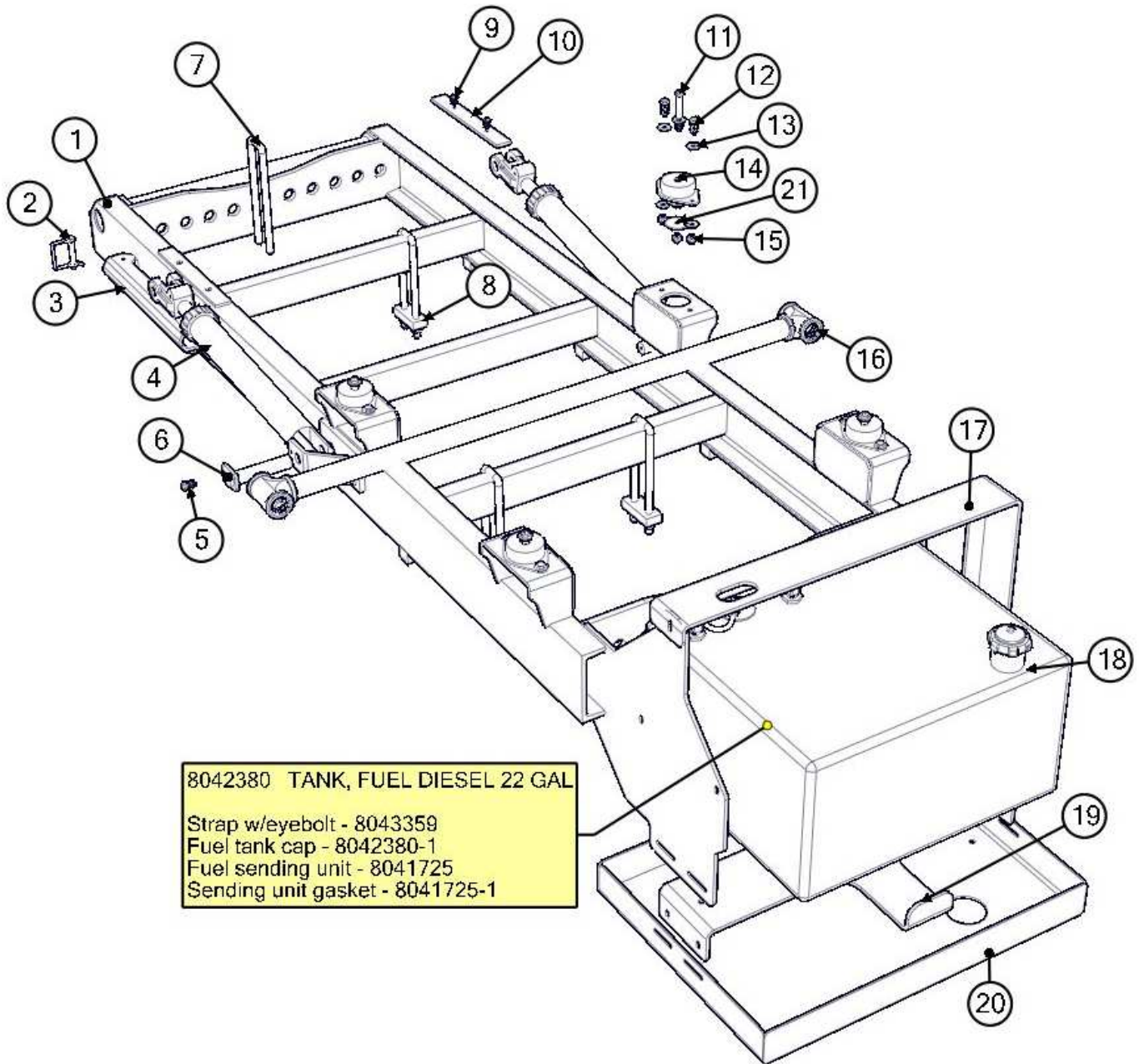

SKID ASSEMBLY

BOM ID	Qty	Name
1	1	8040738 WELDMENT, SKID VX250
2	1	8041213 PIN, SAFETY SNAP
3	1	8042778 TANK SAFETY BRACE
4	2	8040633 CYLINDER, HYD 250ED PUMP
5	2	U000400 SCREW,HC .375-16X.750 ZP G5
6	2	8043844 PIN, CYLINDER FLANGED 1" X 5 1/2"
7	4	8040038 U-BOLT, SKID TRAILER .500 X 10
8	4	8040240 U-BOLT MTG BLOCK
9	4	U030015 SCREW,SFH .250-20X.750 G5
10	2	8041263 STRIP, PLASTIC
11	4	U000560 SCREW,HC .375-16X3.00 ZP G5
12	8	U000420 SCREW,HC .375-16 X 1.00 ZP G5
13	20	U200060 WASHER, FLAT .375 ZP
14	4	8030904 ISOLATOR, POWERPACK
15	12	U120110 NUT, LOCK .375-16 NY ZP
16	2	8041310 TEE,1.25 FP ALL LEGS.GALVANIZE
17	1	8048582 BRACKET, TOOL HOLDER SUPPORT 250
18	1	8042380 TANK, FUEL DIESEL 22 GAL
19	1	8045507 BRACKET, FUEL TANK VSK
20	1	8091685 WELDMENT,FUEL TANK PROTECTOR (OPTIONAL)
21	4	U200064 WASHER FENDER .375 X 2.00

WATER REEL ASSEMBLY

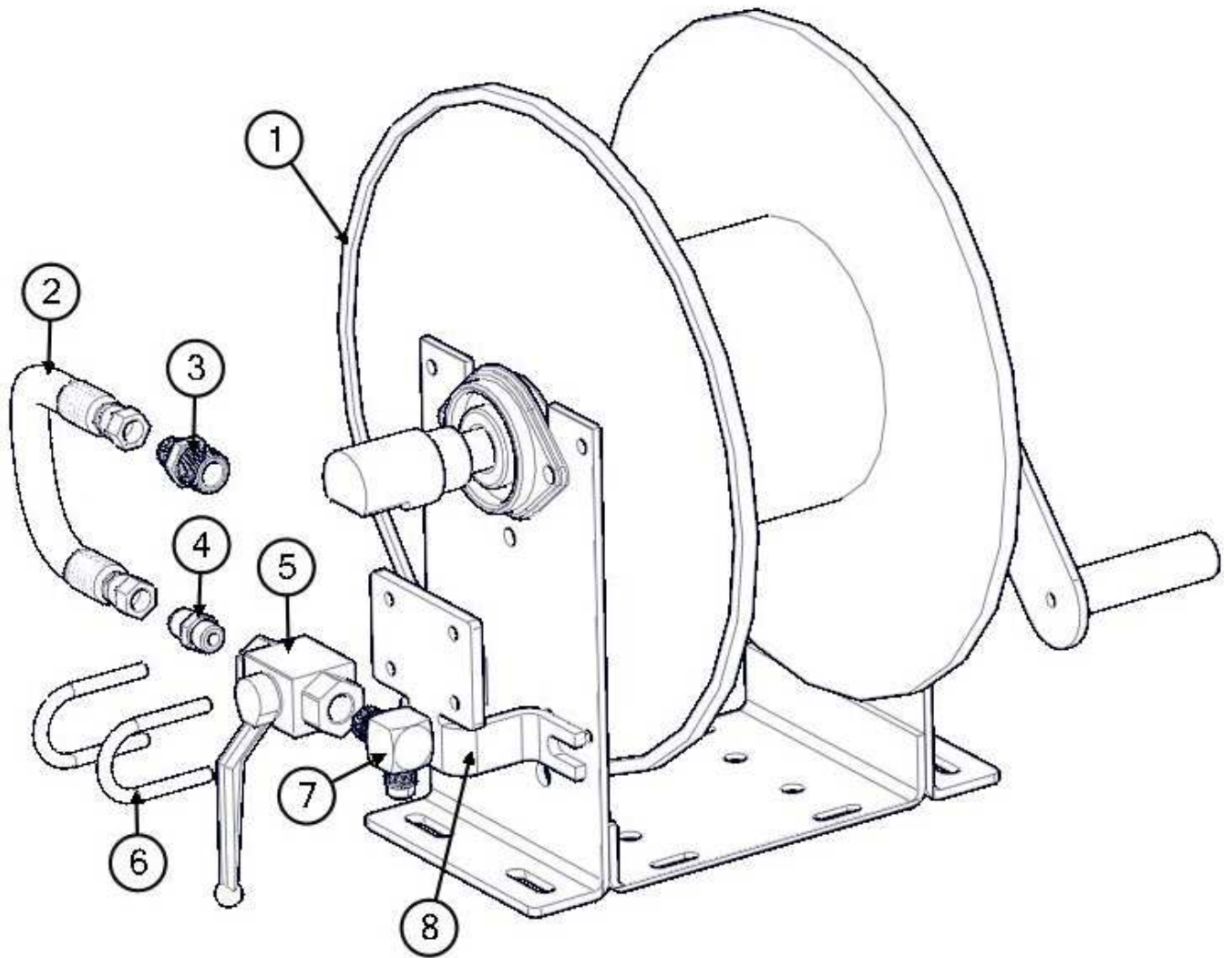

WATER REEL ASSEMBLY

BOM ID	Qty	Name
1	1	8030879 REEL, WATER HANNAY 3/8" X 75'
2	1	8044147 HOSE ASSY VAC 6-10" ST-ST
3	1	T400029 REDUCER 8MP_6MJ
4	1	T400037 UNION 6MB_6MJ
5	1	8030351 VALVE, BALL 3/8"NPT
6	2	U010017 1 1/2" CLAMP HOOK 1/4-20 THD
7	1	T401102 ELBOW 90 6MP_6MJ
8	1	8046740 BRACKET, BALL VALVE

WATER REEL ASSEMBLY

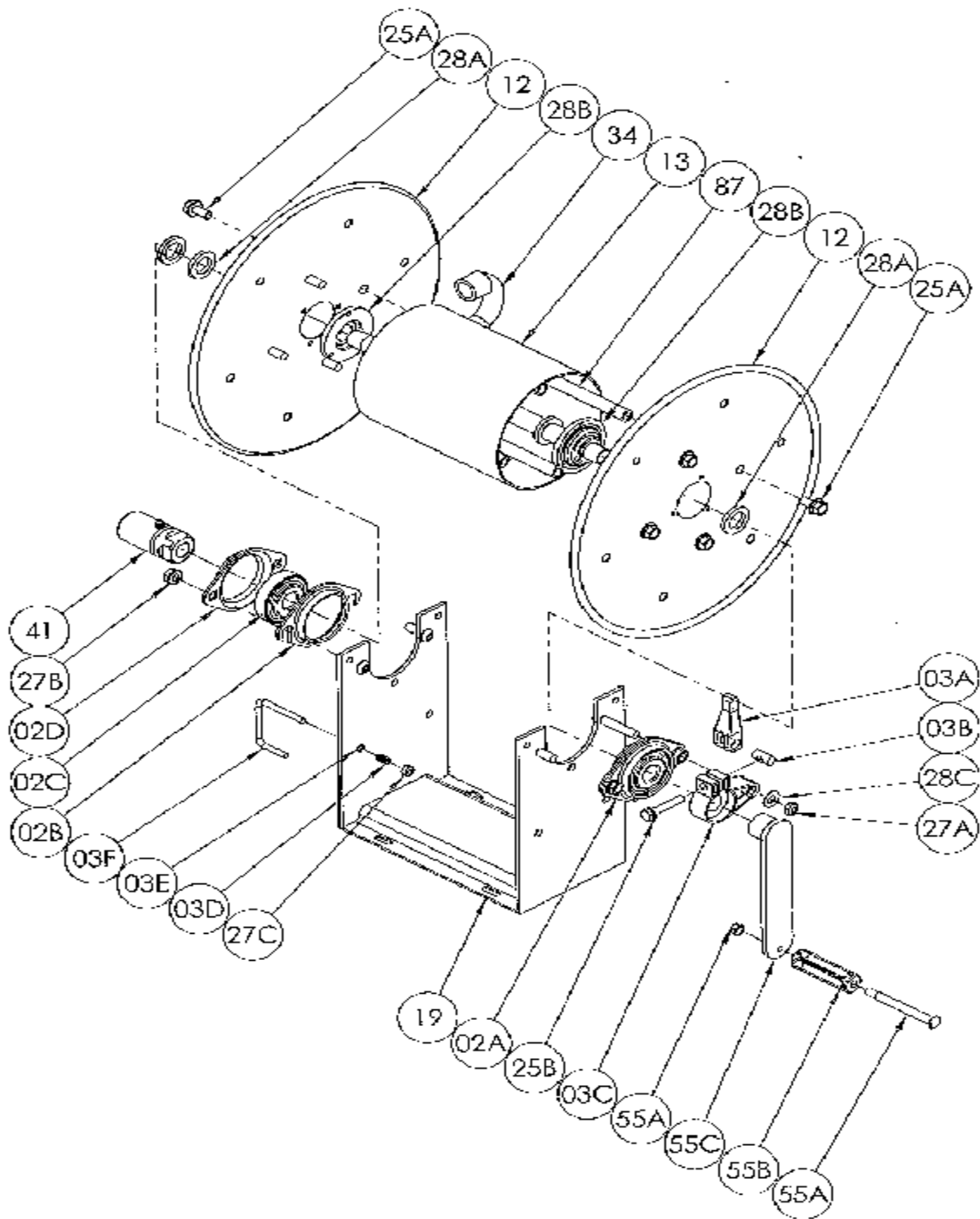

WATER REEL ASSEMBLY

ITEM	QTY	NUMBER	DESCRIPTION
	1	8030879	HOSE REEL, WATER 3/8" X 100
1	2	8030879-02A	1/2" SELF ALIGNING BEARING for 1000 SERIES (INCLUDES 02B, 02C and 02D)
2	2	8030879-02B	SELF ALIGNING BEARING HOLDER SLOTTED
3	2	8030879-02C	1/2" SELF ALIGNING BEARING INSERT
4	2	8030879-02D	SELF ALIGNING BEARING HOLDER
5	1	8030879-03A	CAM LOCK LEVER
6	1	8030879-03B	BRASS BARREL NUT for CAM LOCK BRAKE
7	1	8030879-03C	CAM LOCK DRAG BRAKE BODY for 1/2" HUBS
8	1	8030879-03D	SPRING for PL-3 PINLOCK (1" LONG X 0.32"OD X 0.26"ID)
9	1	8030879-03E	PINLOCK MOUNTING SLEEVE (NOT FIELD INSTALLABLE)
10	1	8030879-03F	PL-3 PINLOCK
11	1	8030879-03G	CAM LOCK KIT (INCLUDES 03A, 03B, 03C and 25B)
12	1	8030879-03H	PL-3 PINLOCK KIT (INCLUDES 03D, 03E, 03F and 27C)
13	2	8030879-12	(14-16) 14.25" DIAMETER DISC 18GA STEEL - SPECIFY MODEL
14	1	8030879-13	DRUM, 6" DIAMETER ALUMINUM - SPECIFY MODEL
15	1	8030879-19	STEEL FRAME ASSY. FOR 1000 SERIES REEL - SPECIFY MODEL
16	8	8030879-25A	3/8"- 16 X 3/4" SPINLOCK BOLT
17	1	8030879-25B	5/16" - 18 X 1 3/4" HEX HEAD BOLT w/ NYLOCK PATCH
18	1	8030879-27A	3/8" - 16 HEX HEAD NUT (ESNA)
19	4	8030879-27B	3/8"- 16 SPINLOCK NUT
20	1	8030879-27C	1/4"-20 HEX HEAD HUT (ESNA)
21	3	8030879-28A	1 3/8"OD X 7/8"ID X 3/16" HUB SPACER WASHER
22	2	8030879-28B	1/2" HUB DISC WASHER, per P28A-00050
23	1	8030879-28C	3/8" SAE FLAT WASHER (13/16"OD)
24	1	8030879-34	1/2" WELDED STEEL HUB - SPECIFY MODEL and OUTLET FITTING
25	1	8030879-41	1/2" 90 DEGREE F x F SUPER SWIVEL (AFLAS PACKING)
26	1	8030879-55A	3/8" SHOULDER BOLT and NUT for plastic crank handle
27	1	8030879-55B	BLACK PLASTIC CRANK HANDLE
28	1	8030879-55C	HAND CRANK (INCLUDES 55A and 55B)
29	4	8030879-87	ANODIZED ALUMINUM THREADED SPACER TUBE

WATER REEL ASSEMBLY

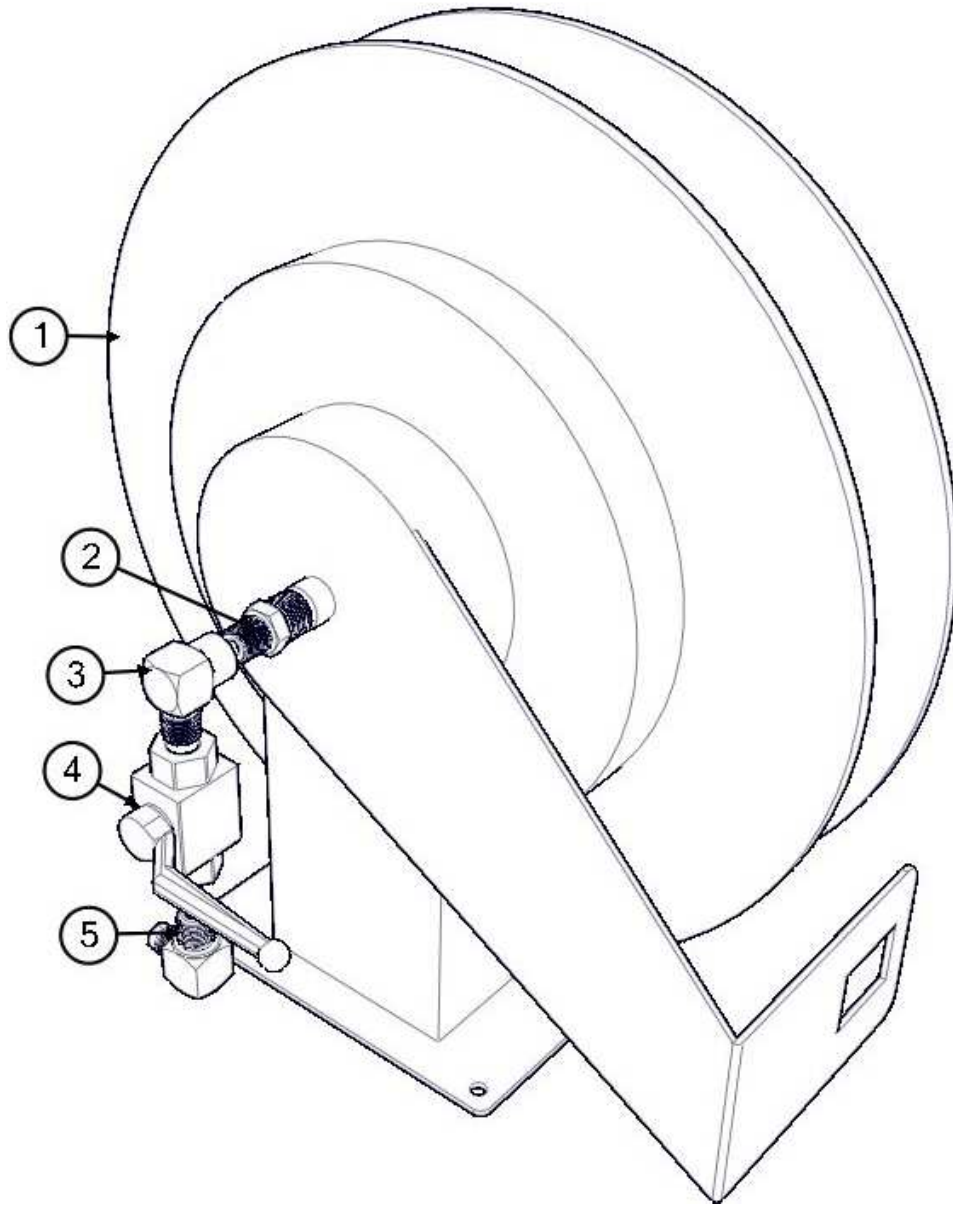

WATER REEL ASSEMBLY

BOM ID	Qty	Description
1	1	8031240 REEL, W/HOSE SPRINGDRIVEN 3/8" X 50'
2	1	T400805 REDUCER 8MP_6MP
3	1	T401065 ELBOW 90 6MP_6FP
4	1	8030351 VALVE, BALL 3/8"NPT
5	1	T401102 ELBOW 90 6MP_6MJ

WATER REEL ASSEMBLY

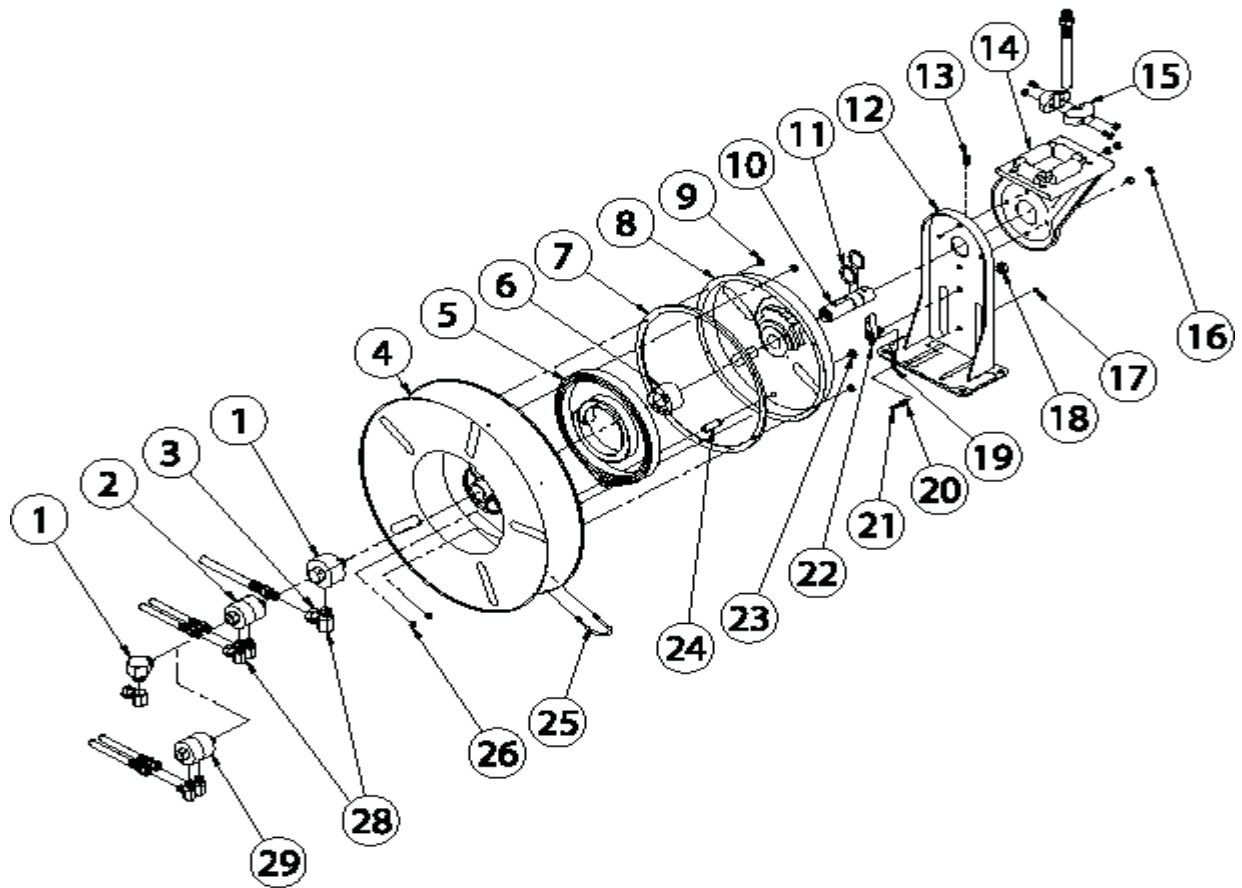

WATER REEL ASSEMBLY

ITEM	QTY	NUMBER	DESCRIPTION
		8031240	REEL with HOSE SPRINGDRIVEN 3/8" X 50'
1	1	8031240-1	SWIVEL ASSEMBLY
2	1	8031240-2	SWIVEL & ELL ASSEMBLY
3	1	8031240-3	90 DEG ELL
4	1	8031240-4	SHEAVE ASSEMBLY
5	1	8031240-5	DRIVE SPRING ASSEMBLY
6	1	8031240-6	SPRING ARBOR ASSEMBLY
7	1	8031240-7	GASKET
8	1	8031240-8	SPRING CASE ASSEMBLY
9	6	8031240-9	10-32 HEX LOCKNUT
10	1	8031240-10	MAIN SHAFT
11	2	8031240-11	1 1/4" SNAP RING
12	1	8031240-12	BASE ASSEMBLY
13	1	8031240-13	1/2"-13 SET SCREW
14	1	8031240-14	GUIDE ARM W/ ROLLERS
15	1	8031240-15	HOSE BUMPER ASSEMBLY
16	4	8031240-16	5/16"-18 LOCKNUT
17	1	8031240-17	10-32 X 3/8" NYLOCK NUT
18	1	8031240-18	1/2"-20 X 5/8" HEX NUT
19	1	8031240-19	LATCH SPRING
20	1	8031240-20	BUSHING
21	1	8031240-21	10-32 X 7/8" SCREW
22	1	8031240-22	LATCH PAWL ASSEMBLY
23	1	8031240-23	3/8"-24 JAM NUT
24	1	8031240-24	SPRING CASE STUD
25	1	8031240-25	U-BOLT
26	4	8031240-26	1/4"-20 X 3/8" LOCKNUT
28	1	8031240-28	SWIVEL UNION

WATER TANK ASSEMBLY 50 GALLON SADDLE

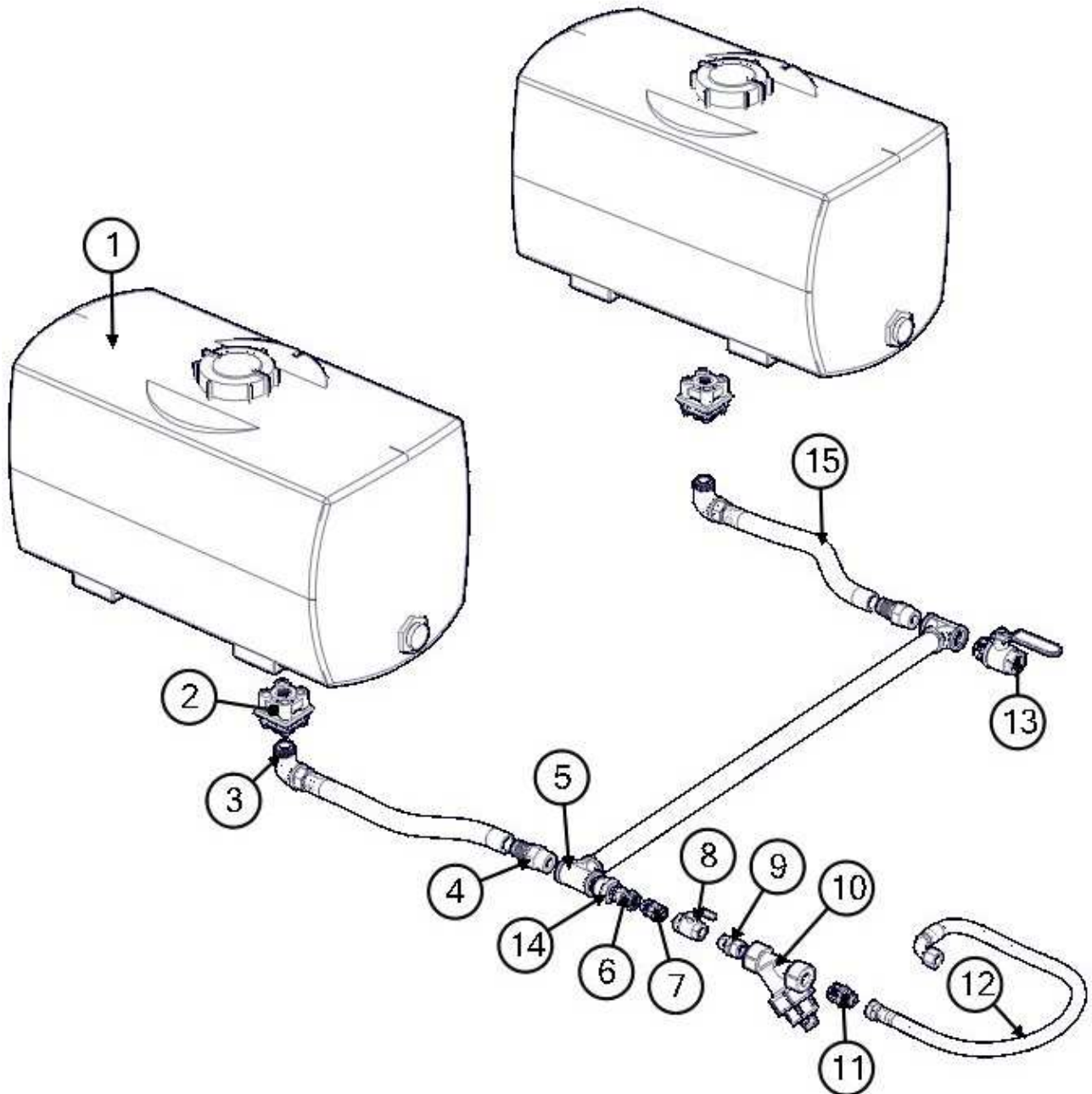

**WATER TANK ASSEMBLY
50 GALLON SADDLE**

BOM ID	Qty	Name
1	2	8034151 TANK, WATER 50 GAL
2	2	8045093 BULKHEAD, 1 1/4" BOTTOM
3	2	8041311 ELBOW,90 1.25 STREET EL GALVAN
4	4	8041312 FITTING 20MP_20HB
5	2	8041310 TEE,1.25 FP ALL LEGS.GALVANIZE
6	1	T400101 UNION 12FJ_12MP
7	1	T400100 UNION 12MP_12MJ
8	1	T000185 VALVE, BALL 3/4" FNPT BRASS
9	1	T404060 REDUCER 16MP_12MP
10	1	8040186 STRAINER, Y 1" BANJO
11	1	T400450 REDUCER 16MP_12MJ
12	1	8041058 HOSE VAC PUSH 12-36
13	1	8045813 VALVE, BALL 1 1/4 M X F BRASS.ipt
14	1	T403100 REDUCER 20MP-12FP
15	2	8041523 HOSE VAC CLEAR VINYL 1 1/4"-24"LG

WATER TANK ASSEMBLY 100 GALLON SINGLE

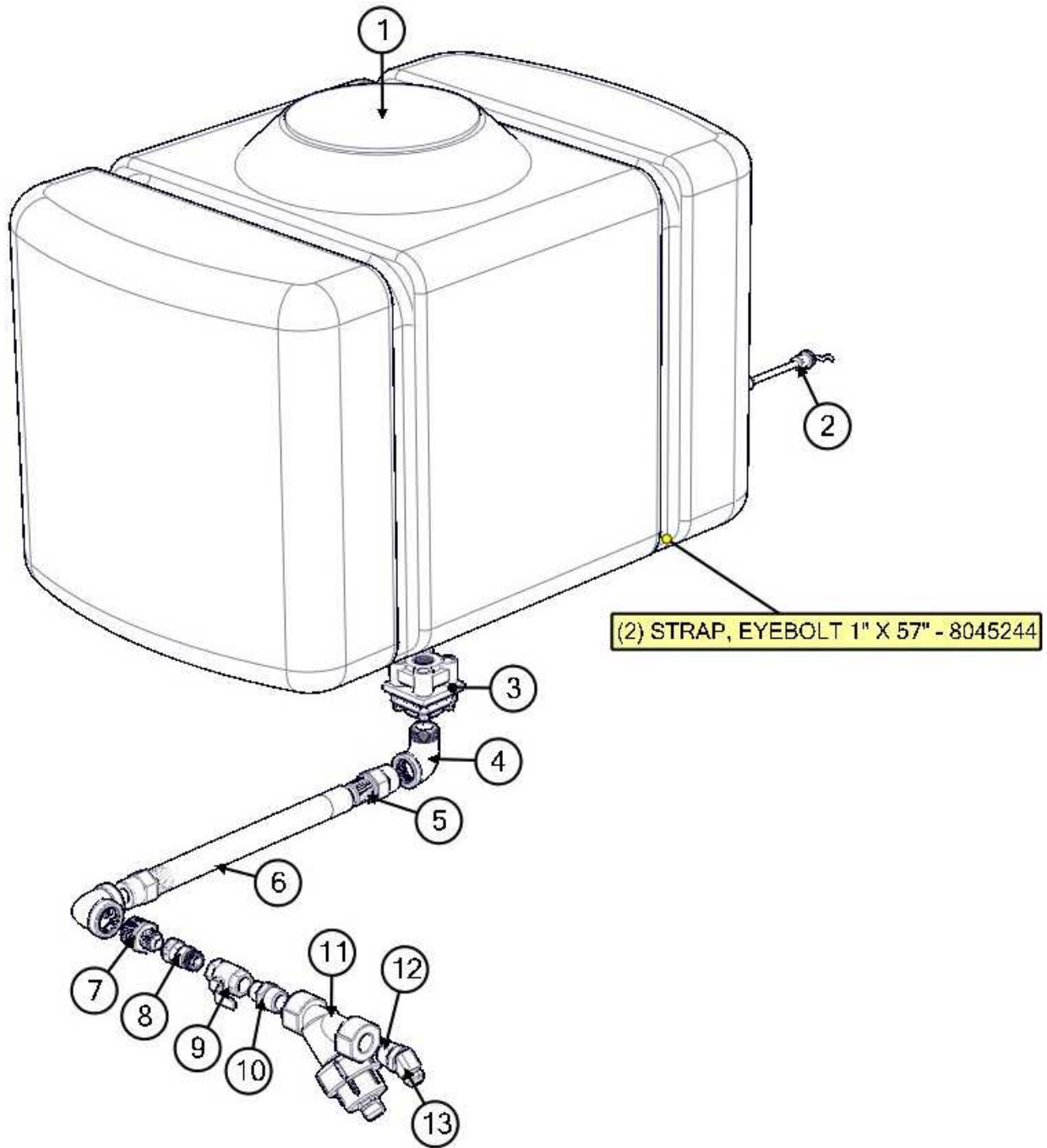

**WATER TANK ASSEMBLY
100 GALLON SINGLE**

BOM ID	Qty	Description
1	1	8041435 TANK, WATER 100 GAL
2	1	8090896 SWITCH, WATER LEVEL (HORIZ)
3	1	8045093 BULKHEAD 1 1/4" BOTTOM FEED
4	1	8041311 ELBOW,90 1.25 STREET EL GALVAN
5	2	8041312 FITTING 20MP_20HB
6	1	8041525 HOSE VAC CLEAR VINYL 1 1/4" X 12"
7	1	T403017 REDUCER 20MP_12MJ
8	1	T400101 UNION 12FJ_12MP
9	1	T000185 VALVE, BALL 3/4" FNPT BRASS
10	1	T404060 REDUCER 16MP_12MP
11	1	8040186 STRAINER, Y 1" BANJO
12	1	T403080 REDUCER 16MP_12FP
13	1	8031252 ELBOW 45 12MP_12MJ

HYDRAULIC PUMP ASSEMBLY

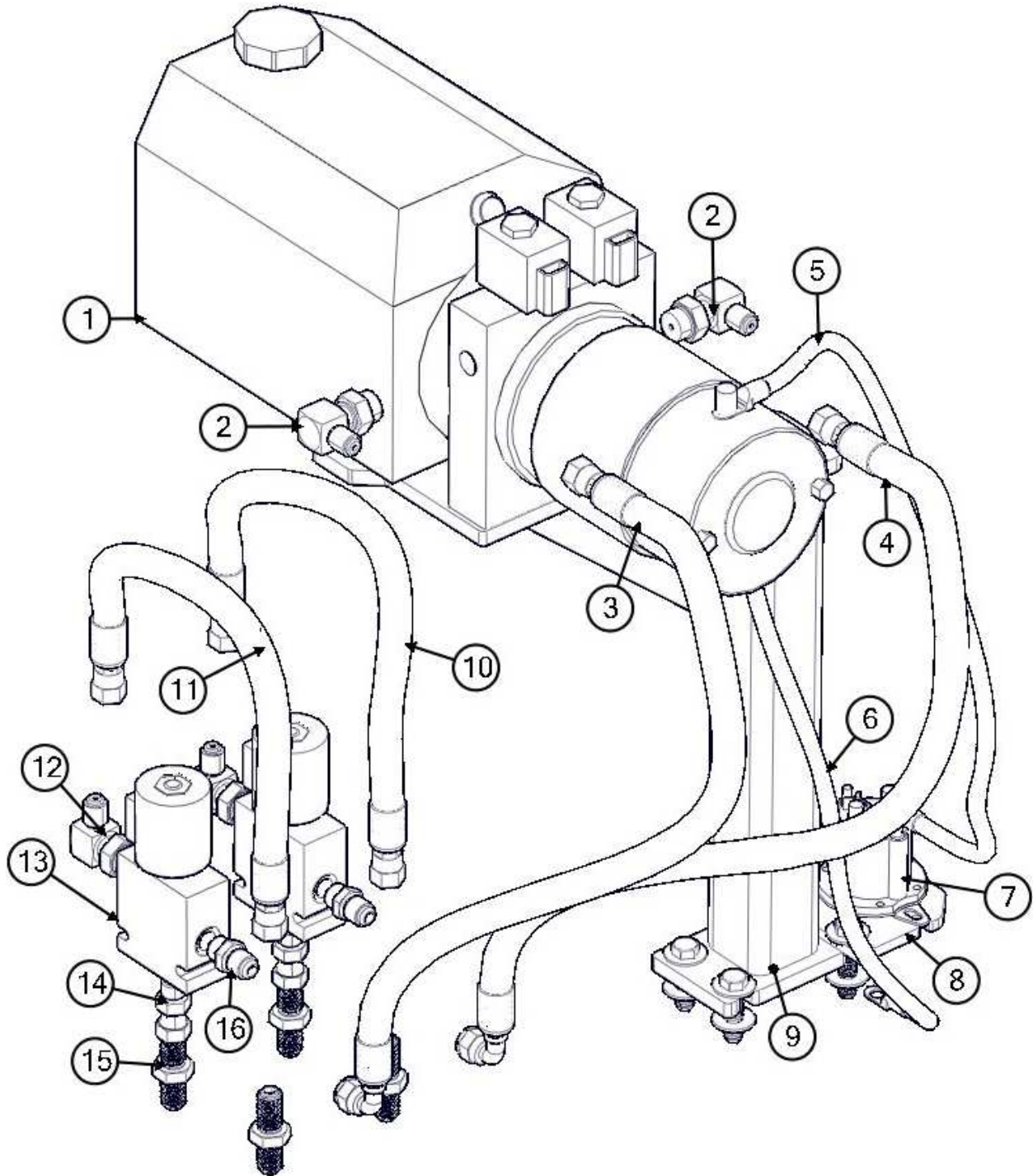

HYDRAULIC PUMP ASSEMBLY

BOM ID	Qty	Name
1	1	8046300 PUMP, HYD. 12V 4.5QT
2	2	T401250 ELBOW 90 6MB_6MJ
3	1	8046687 HOSE ASSY VAC 6-23" ST-90
4	1	8046685 HOSE ASSY VAC 6-25" ST-90
5	1	X300233 CABLE BATTERY HOT 1GA 26"
6	1	X300224 CABLE BATTERY GROUND 1GA 21"
7	1	8046258 SWITCH HYD. PUMP 12V RELOCATE
8	1	8046127 BRACKET, PUMP SOLENOID
9	1	8043499 BRACKET, 12V HYD. PUMP
10	1	8040971 HOSE ASSY VAC 4-19 ST-ST
11	1	8040971 HOSE ASSY VAC 4-19 ST-ST
12	2	T401250 ELBOW 90 6MB_6MJ
13	2	8041788 VALVE, SOLENOID 3-WAY W/INT C4K
14	2	T400036 UNION 6M
15	4	T400391 BULKHEAD 6MJ_6MJ
16	2	T400037 UNION 6MB_6MJ

HYDRAULIC PUMP

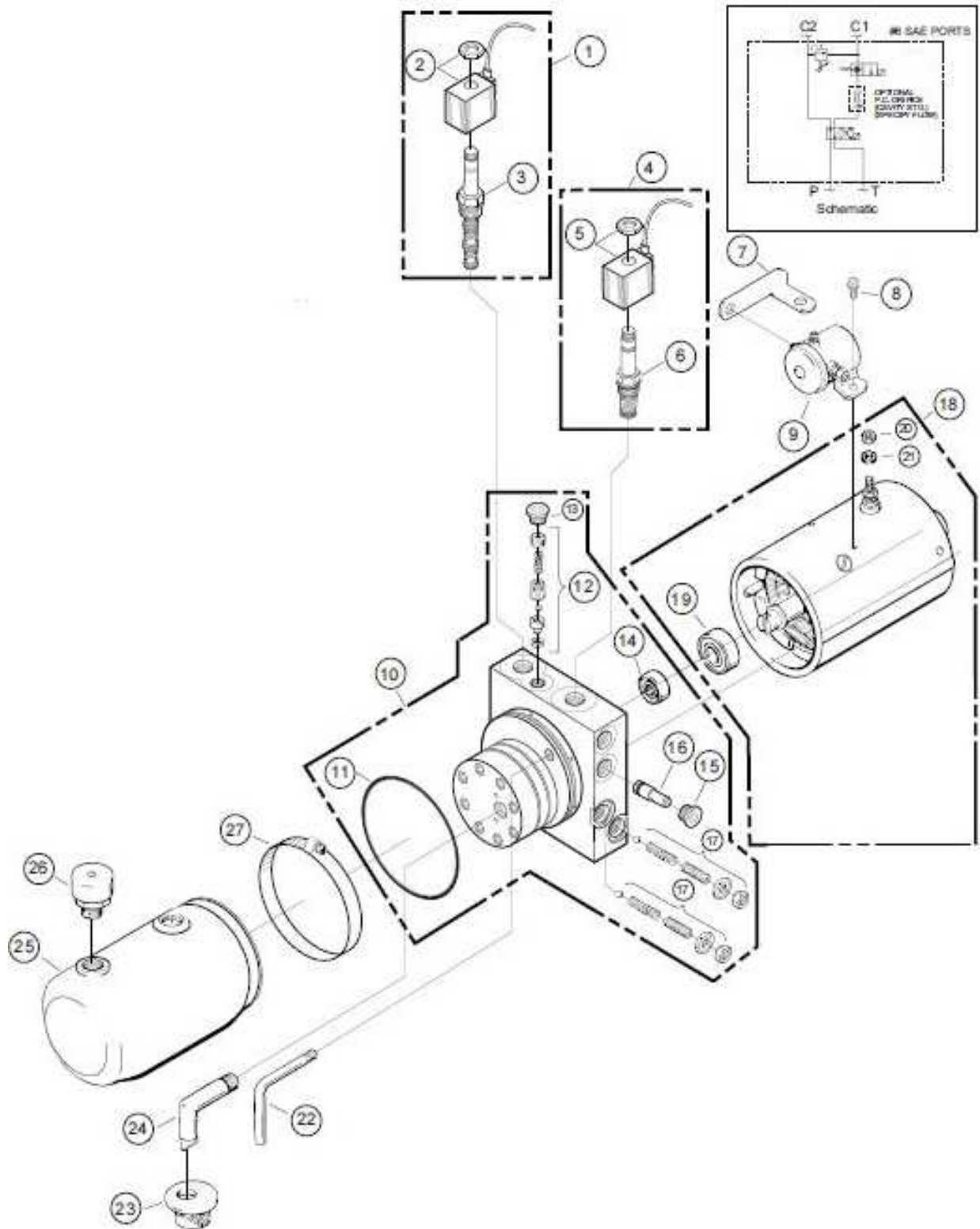

HYDRAULIC PUMP

ITEM	QTY	NUMBER	DESCRIPTION
	1	8040486	HYDRAULIC PUMP 12V 3QT
		8045355	HYDRAULIC PUMP 12V 6QT (HYDRAULIC DOOR OPTION)
	2	U000420	SCREW, HC 3/8"-16 X 1
	2	U210060	WASHER, LOCK 3/8"
	2	U200600	WASHER, FLAT 3/8"
	2	T400037	UNION 6MB-6MJR
	2	8040973	HOSE ASSY VAC 6-20 ST-90
	2	T400391	BULKHEAD 6MP 6MP
1	1	8041601-14	VALVE, 4 WAY - 2 POSITION (12V)
2	1	8041601-15	COIL, 10VDC GROUNDED W/DEUTSCH CONN
3	1	8041601-16	CARTRIDGE, 4 WAY - 2 POSITION
4	1	8041601-17	VALVE, 2 WAY - 2 POSITION (12V) GROUNDED
5	1	8041601-18	COIL, 10 VDC, 2 WAY-2 POS GRND W/DEUTSCH CONN
6	1	8041601-19	VALVE 12V HYD 2 WAY-2 POS
7	1	8041601-20	STRAP, MOTOR SOLENOID CONNECTING
8	2	8041601-21	SCREW, RND HD MACH 10-32 X 1/4"
9	1	8041601-22	SWITCH, SOLENOID 12VDC, 3 POST GRND
10	1	8041601-23	PUMP ASSY
11	1	8041601-24	O-RING INDUST 3-5/8 X 3-7/8 X 1/8
12	1	8041601-25	PARTS KIT-VALVE ASSY, POPPET/BALL CHECK
13	1	8041601-26	PLUG
14	1	8041601-27	SEAL
15	1	8041601-28	PLUG, #8 SAE
16	1	8041601-29	VALVE, PRESS, COMP ORIFICE
17	2	8041601-30	PARTS KIT, RELIEF VALVE
18	1	8041601-31	MOTOR, ELECTRIC 12 VDC
19	1	8041601-32	BEARING, BASE, MOTOR
20	1	8041601-33	NUT, HEX 5/16-24
21	1	8041601-34	WASHER, LOCK 5/16"
	2	8041601-38	SCREW, HEX HEAD, 1/4-20 X 1-3/8"
	1	8041601-41	PLUG, 3/8" NPTF
22	1	8041601-42	TUBE, RETURN (1/8")
23	1	8041601-43	SCREEN, FILTER (SUCTION)
24	1	8041601-44	TUBE, FILTER SUCTION 3/8 NPT 90 DEG
25	1	8041601-45	6QT RESEVOIR POLY
	*	8040486-45	3QT RESEVOIR POLY
	*	8041601-48	4.5QT RESEVOIR POLY
26	1	8041601-46	PLUG, VENT, 3/8" NPT
27	1	8041601-47	CLAMP, HOSE WORM GEAR (IN SERIES)
*	1	X200002	HYDRAULIC PUMP WIRE HARNESS
*	1	8043499	HYDRAULIC PUMP MOUNT
		8044297	HYDRAULIC PUMP MOUNT (REVERSE FLOW)
		8045336	HYDRAULIC PUMP MOUNT (412 BLOWER)

*NOT SHOWN

ENCLOSURE ASSEMBLY 31HP REV CONTROL

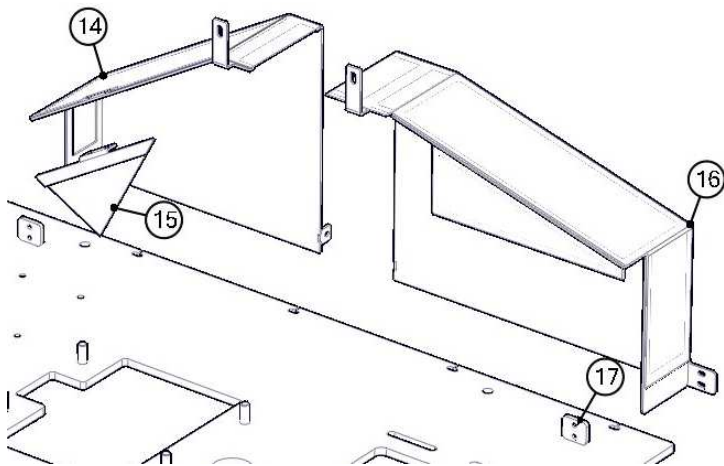
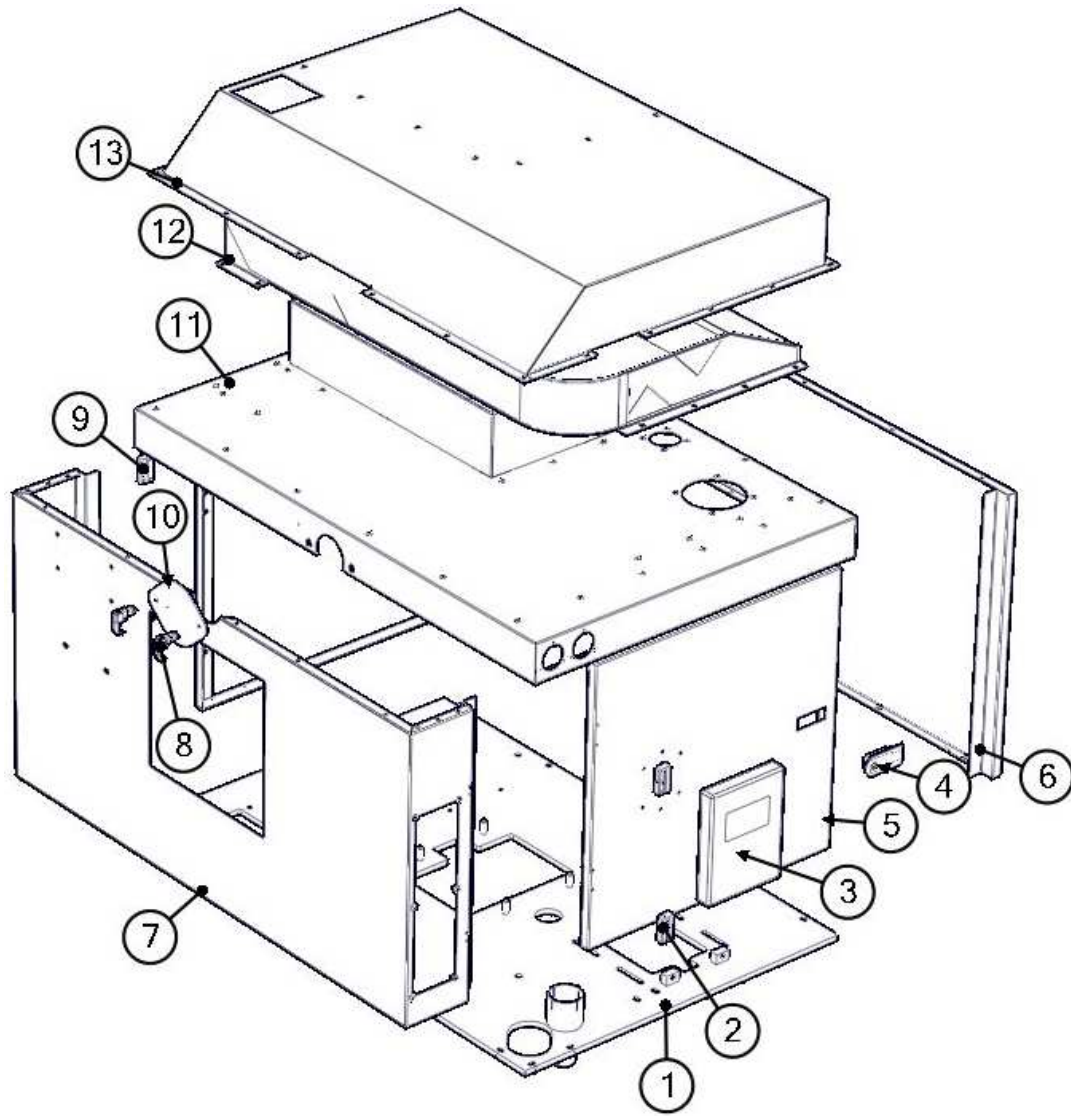

ENCLOSURE ASSEMBLY

31HP REV CONTROL

BOM ID	Qty	Name
1	1	8046549 MAIN PLATE 31LE
2	2	8040589 HINGE, OFFSET TYPE "B"
3	1	E250210 BOX, PLASTIC FOR SAFETY MANUAL
4	2	8040586 LATCH, SEALED LEVER
5	1	8045091 PANEL, 31LE DOOR W/MANUAL WELDMENT
6	1	8046663 PANEL, 31LE REAR WELDMENT (OPP)
7	1	8045455 PANEL, 31LE FRONT WELDMENT
8	2	8040334 LATCH, SWELL
9	2	8040588 HINGE, OFFSET TYPE "A"
10	1	8040592 ENCLOSURE RADIATOR COVER
11	1	8045524 WELDMENT, 31LE TOP (OPP)
12	1	8045096 WELDMENT, HEAT SHIELD 31LE
13	1	8045125 WELDMENT, INTAKE BOX 31LE
14	1	8091700 WELDMENT, BELT GUARD WP to ENG (OPTIONAL)
15	1	8091702 BELT GUARD, BACKSIDE (OPTIONAL)
16	1	8091701 WELDMENT, BELT GUARD BLOWER to ENG (OPTIONAL)
17	2	8091750 MOUNTING TAB, BELT GUARD

ENCLOSURE ASSEMBLY

31HP

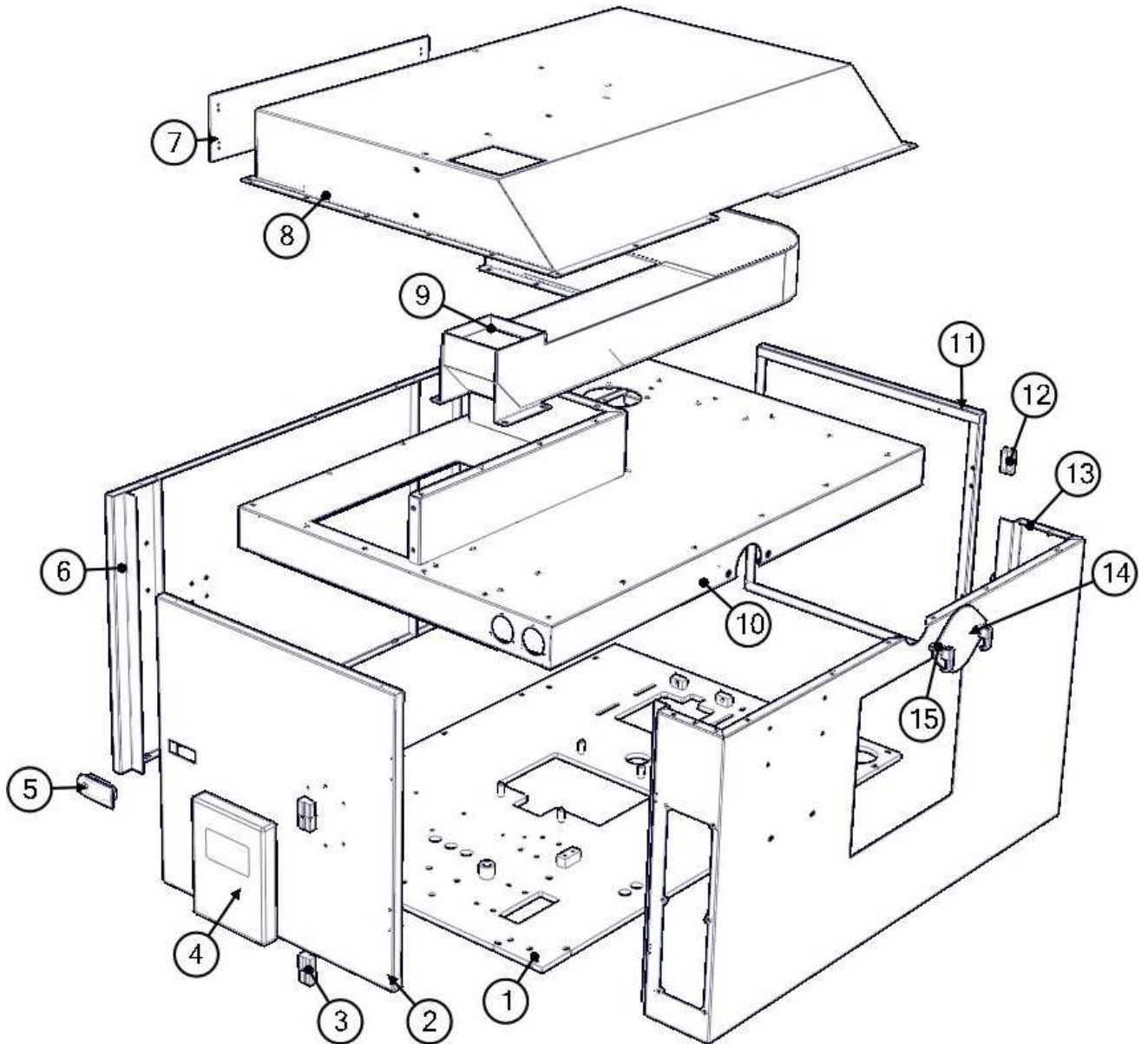

ENCLOSURE ASSEMBLY

31HP

BOM ID	Qty	Description
1	1	8046549 MAIN PLATE 31LE
2	1	8045091 PANEL, DOOR W/MANUAL BOX 31LE
3	2	8040588 HINGE, OFFSET TYPE "B"
4	1	E250210 BOX, PLASTIC FOR SAFETY MANUAL
5	2	8040586 LATCH, SEALED LEVER
6	1	8045088 PANEL, REAR 31LE WELDMENT
7	1	8090877 INTAKE BOX COVER 31HP
8	1	8045125 INTAKE BOX 31LE
9	1	8045096 WELDMENT, HEAT SHIELD 31LE
10	1	8045090 PANEL, TOP 31LE WELDMENT
11	1	8045092 PANEL, DOOR 31LE
12	2	8040589 HINGE, OFFSET TYPE "A"
13	1	8045086 PANEL, FRONT 31LE WELDMENT
14	1	8040592 COVER, RADIATOR ENCLOSURE
15	2	8040334 LATCH, SWELL

CONTROL PANEL ASSEMBLY

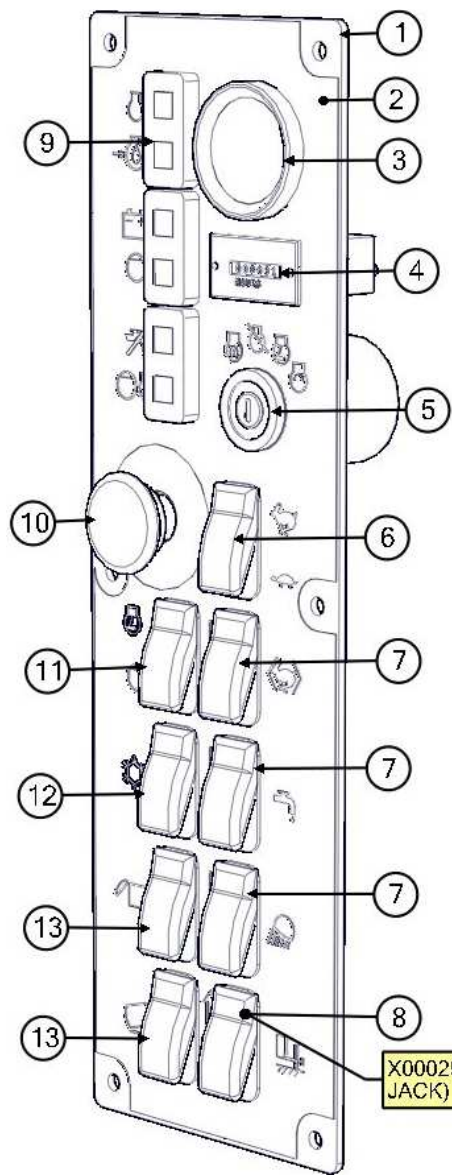

X000290 - PLUG (WHEN NO HYD. JACK)

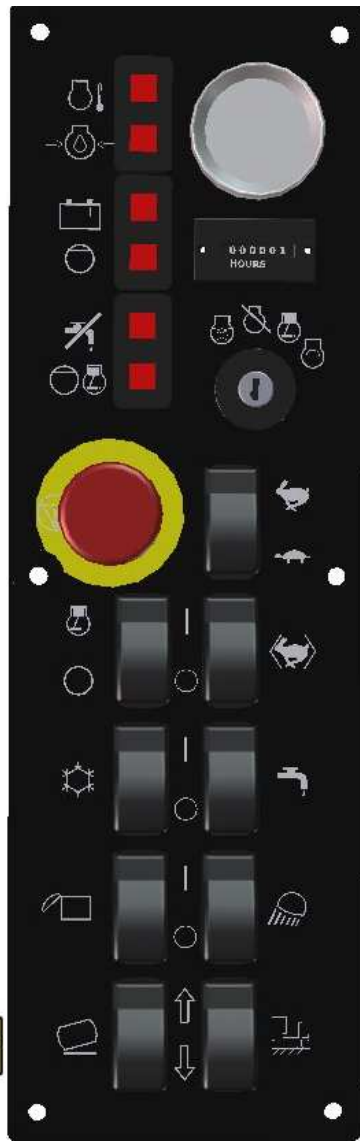

CONTROL PANEL ASSEMBLY

BOM ID	Qty	Name
1	1	8043128 PLATE, MAIN CONTROL PANEL
2	1	J200031 DECAL, CONTROL PANEL
3	1	8030330 GAUGE, FUEL
4	1	X000300 HOUR METER
5	1	8030458 SWITCH, IGNITION
6	1	X000271 ROCKER SWITCH DPST ON-ON
7	3	X000270 ROCKER SWITCH SPST ON-OFF
8	1	X000274 ROCKER SWITCH DPST (ON) OFF (ON)
9	3	X000260 LIGHT, LED DUAL PANEL
10	1	X000280 E-STOP
11	1	X000273 ROCKER SWITCH SPST (ON) NONE -OFF
12	1	X000272 ROCKER SWITCH DPST (ON) NONE-ON
13	2	X000274 ROCKER SWITCH DPST (ON) OFF (ON)

ELECTRICAL CONTROL BRACKET ASSEMBLY

- (Bussman Control Center)
- 7 X000205 FUSE 5A
 - 2 X000206 FUSE 10A
 - 2 X000207 FUSE 20A
 - 3 X000237 FUSE 30A
 - 1 X000236 CIRCUIT BREAKER 20A
 - 1 X000210 CIRCUIT BREAKER 30A
 - 6 X000209 RELAY 35A/25A
 - 5 X000208 DIODE 6A

- 8043800 - FUSE HOLDER AMG
- 1 8043801 FUSE 250A AMG

HARNESS VAC CONTROL - X200005

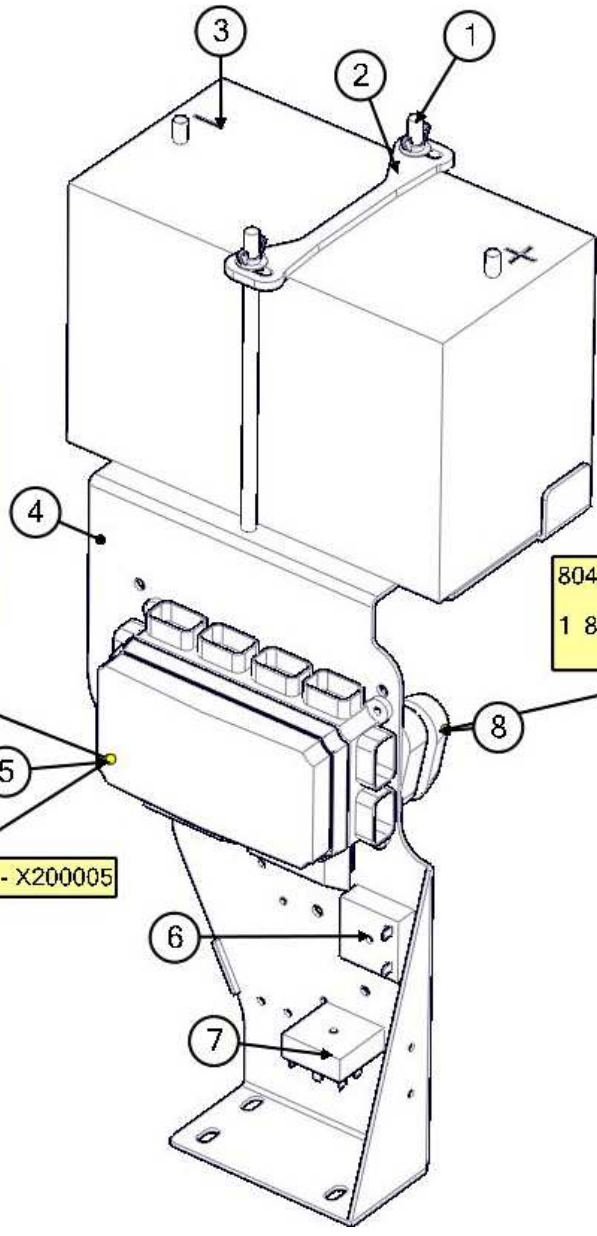

ELECTRICAL CONTROL BRACKET ASSEMBLY

BOM ID	Qty	Name
1	2	8043742 BATTERY HOLD DOWN ROD ASSEMBLY
2	1	8050016 BATTERY HOLD DOWN
3	1	X400050 BATTERY, 31-MHD WORKAHOLIC
4	1	8043127 BRACKET, CONTROL PANEL HARNESS MTG
5	1	X000239 BUSSMAN VEC
6	1	8042282 SWITCH, DELAY RELAY
7	1	X000241 RELAY TIMER 15 SEC SHUTDOWN
8	1	8043800 FUSE HOLDING AMG

ENGINE ASSEMBLY

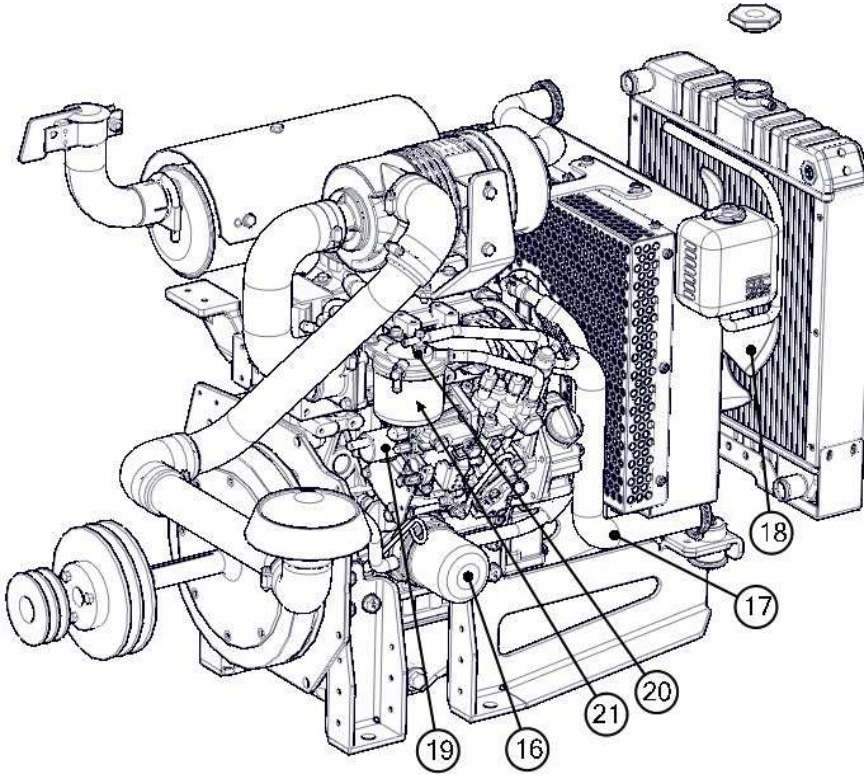
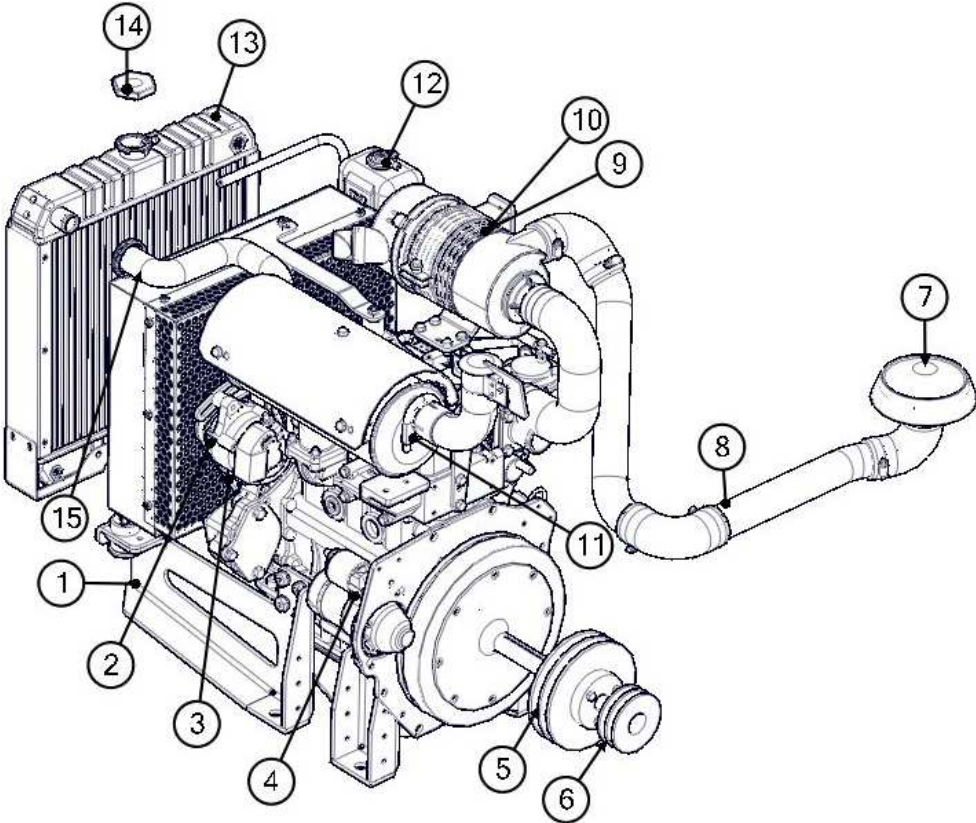

ENGINE ASSEMBLY

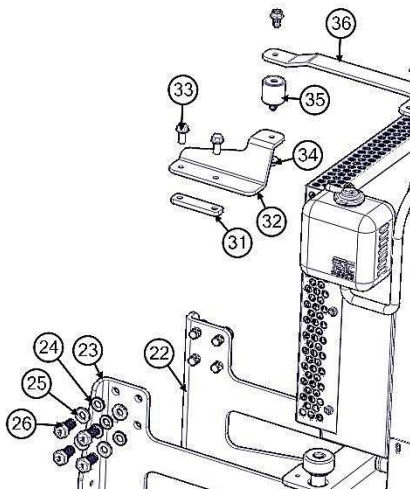

NOT SHOWN:

- 1 8045279 THROTTLE SOLENOID
- 1 8045282 MURPHY SWITCH
- 1 8045283 KEY SWITCH
- 1 8045617 KEY
- 1 8045287 SOLENOID SPRING
- 1 8047108 BRACKET, WATER SEPARATOR
- 1 8047265 OIL/WATER SEPARATOR
- 1 X300297 CABLE BATTERY KIT 31LE W/ELECT. HYD PUMP

BOM ID	Qty	Name
1	1	8045083 ENGINE YANMAR 31HP
2	1	8045083-3 ALTERNATOR
3	1	8045083-2 BELT, FAN
4	1	8045083-1 STARTER
5	1	8040484 SHEAVE, 6.96in OD SDS BLOWER
6	1	8030970 SHEAVE, 2MAL34_2AK34H
7	1	8045083-30 CAP, AIR CLEANER IN-TAKE
8	1	8048482 HOSE, AIR CLEANER 31HP 250
9	1	8045080-7 HOUSING, AIR FILTER
10	1	8045277 ELEMENT, AIR FILTER
11	1	8045083-8 MUFFLER
12	1	8045083-12 TANK, OVERFLOW (SOLD W/CAP)
13	1	8045083-02 RADIATOR
14	1	8045083-11 CAP, RADIATOR
15	1	8045083-9 HOSE, UPPER RADIATOR
16	1	8045083-13 FILTER, OIL
17	1	8045083-10 HOSE, LOWER RADIATOR
18	1	8045083-15 FAN
19	1	8045083-6 SWITCH, OIL PRESSURE
20	1	8045281 FUEL PUMP
21	1	8045280 FILTER, FUEL
22	1	8092791 BRACKET, RIGHT ENG./RADIATOR MOUNT
23	1	8092792 BRACKET, LEFT ENG./RADIATOR MOUNT
24	8	U200306 WASHER, FLAT 12MM
25	8	U210224 WASHER, LOCK HELICAL SPRING 12MM
26	8	U001653 SCREW, HC 12MM X 1.75 X 25MM
27	2	U000905 SCREW, HC .500-13 X 2.50"
28	2	U200115 WASHER, FLAT .500 X 2.00 X .125
29	2	8092793 ISOLATOR, RADIATOR 46.4MM,51.21MM,1.2-13
30	1	8092794 PLATE, RADIATOR BOTTOM BRACKET
31	1	8092795 SPACER
32	1	8092796 MOUNT, UPPER RADIATOR
33	2	U100006 SCREW, HC FLANGED SERRATED 8MM-1.25 X 20MM
34	1	U100007 NUT, FLANGED SERRATED 8MM-1.25
35	1	8092797 ISOLATOR, 32X32, M8-1.25
36	1	8092798 SUPPORT, UPPER RADIATOR
37	3	U001595 SCREW, HC SERRATED FLANGED 8MM-1.25 X 20MM

BLOWER ASSEMBLY

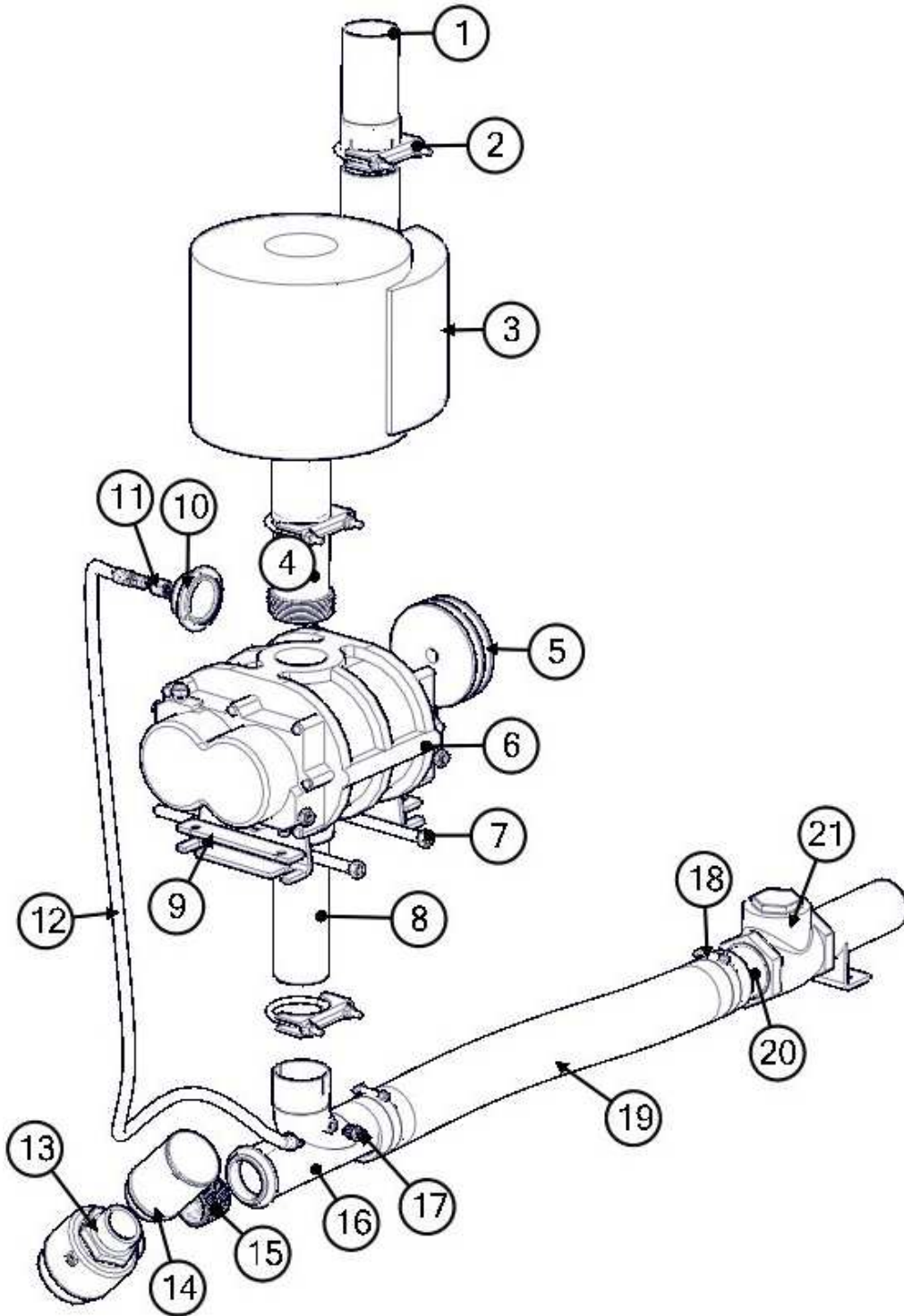

BLOWER ASSEMBLY

BOM ID	Qty	Name
1	1	8045205 BLOWER EXHAUST EXTENSION
2	3	8030395 3in U-Bolt Clamp
3	1	8030332 SILENCER 500CFM COWL
4	1	8045238 UNION EXHAUST 3in OD-MNPT
5	1	8040944 SHEAVE, 3.95in OD TAP 2-GROOVE
6	1	8041250 BLOWER 575 ASSEMBLY
7	2	8040751 ROD TIGHTENER WELD'T
8	1	8045219 EXHAUST 3"NPT X 9.625"LG
9	2	8045251 BLOWER BOLT PLATE 47
10	1	8041074 VACUUM GAUGE
11	1	T400110 UNION 4FP_4MJ
12	1	8045254 HOSE ASSY VAC 4-55" ST-90
13	1	8030337 VALVE, 2" AIR RELIEF SET 15"HG (STANDARD)
14	1	8040340 FILTER, AIR 2" KUNKLE VALVE
15	1	8030409 NIPPLE CLOSE 2IN SCHD 40 IRON
16	1	8045476 WYE, EXHAUST 3"OD-3"ID W/2" RED
17	1	T400020 UNION, 4MP-4MJ
18	2	8042605 CLAMP, HOSE T-BOLT 350
19	1	8048413 HOSE VAC AG SUCTION 3-31.5"LG
20	1	8045238 UNION EXHAUST 3in OD-MNPT
21	1	8040799 VALVE, 3" SWING CHECK-MODIFIED

* 1 8030379 BELT, BX51

**URAI-DSL Splash Lubricated Blowers
4" Gear Diameter**

Item #	Qty	Part #	Description
1	1	8041250-1	Headplate Gear End
2	1	8041250-2	Headplate Drive End
3	1	8041250-3	Gearbox
4	2	8041250-4	Timing Gears
7	1	8041250-7	Gasket, Gear Box, DE Cover
11	1	8041250-11	Cylinder
12	1	8041250-12	Impeller & Shaft Drive
13	1	8041250-13	Impeller & shaft Driven
14	3	8041250-14	Bearing, Ball
15	1	8041250-15	Bearing, Roller
16	4	8041250-16	Pin, Dowel
17	2	8041250-17	Gear Nut
19	1	8041250-19	Key
21	3	8041250-21	Plug, Pipe
23	6	8041250-23	Screw Hex
25	1	8041250-25	Breather (Plug Vent)
26	*	8041250-26	Screw, Hex
27	4	8041250-27	Seal, Lip Bearing
31	4	8041250-31	Screw, Hex, Nylock
32	6	8041250-32	Screw, Hex
33	1	8041250-33	Seal Lip-Drive
34	2	8041250-34	Clamp Plate
35	2	8041250-35	Foot
39	4	8041250-39	Washer Mounting
40	2	8041250-40	Screw Socket
42	2	8041250-42	Screw Hex
48	4	8041250-48	DE Oil Slinger Set Screw
50	1	8041250-50	Drive End Cover
52	2	8041250-52	Drive End Oil Slinger
53	2	8041250-53	Oil Sight Glass

*Quantities vary by blower.

WATER PUMP ASSEMBLY (AUS.)

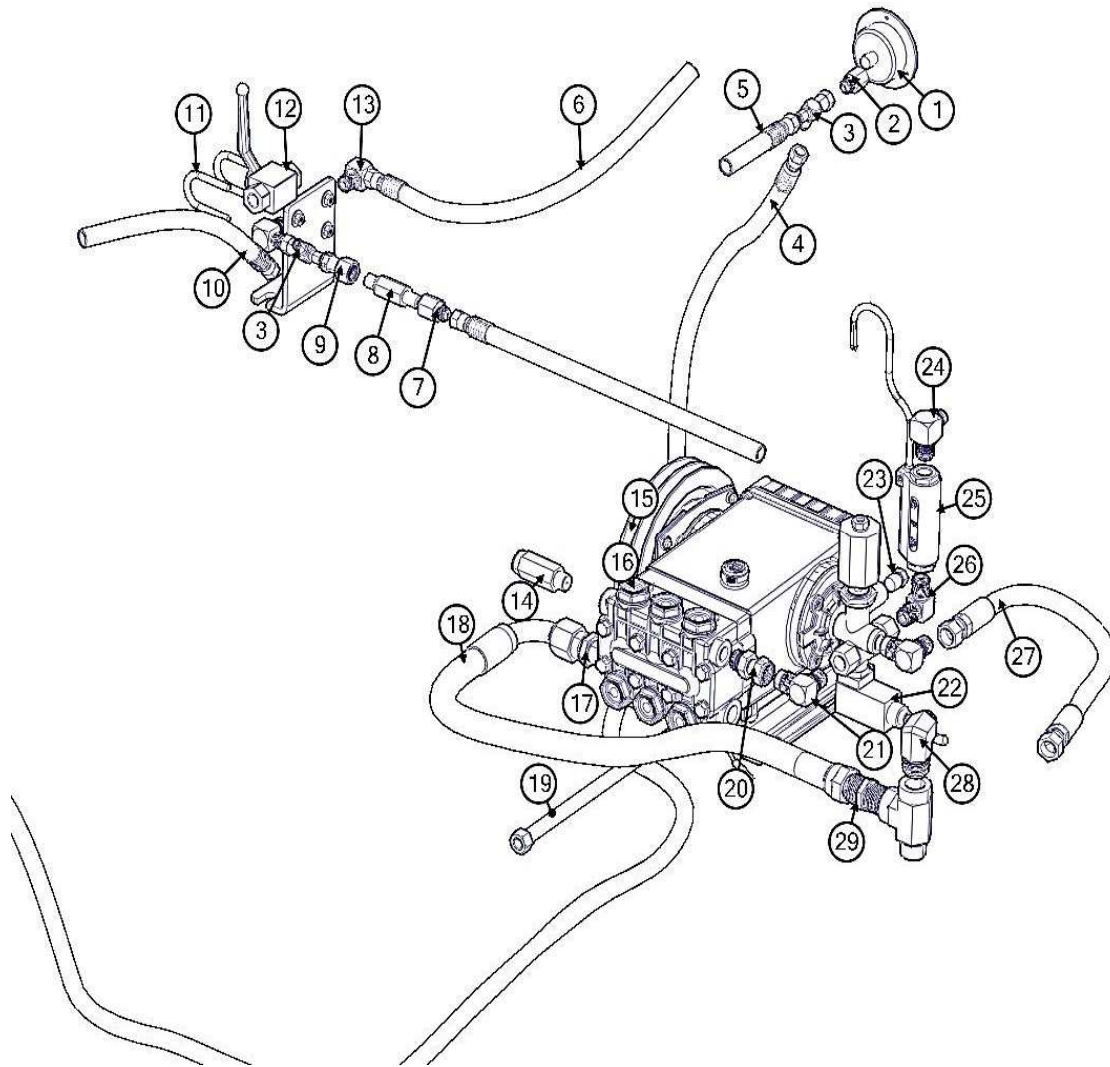

WATER PUMP ASSEMBLY (AUS.)

BOM ID	Qty	Name
1	1	8030372 GAUGE, WATER PRESSURE 1/4"NPT
2	1	8031126 REDUCER 4FP_6MJ
3	2	T402153 TEE, 6MJ-6MJ-6FJ
4	1	8092779 HOSE ASSY VAC 6-83" ST-90
5	1	8092780 HOSE ASSY VAC 6-144" ST-ST
6	1	8042178 HOSE ASSY VAC 6-155" ST-90
7	1	T400031 UNION 6MJ-6FP
8	1	8030923 FILTER, WATER HIGH PRESSURE
9	1	T400083 UNION 6FP-6FJ
10	1	8041152 HOSE ASSY VAC 6-29" ST-ST
11	2	U010017 CLAMP, HOOK 1 1/2" 1/4-20
12	1	8030351 VALVE, BALL STEEL 3/8"NPT
13	2	T401102 ELBOW 90 6MP-6MJ
14	1	8030340 VALVE, SAFETY RELIEF 6GPM
15	1	8030961 CLUTCH, WATER PUMP
16	1	8031279 PUMP, WATER TS2021 5.6@3500
17	1	T400070 REDUCER 12MJ-8MP
18	1	8049365 HOSE ASSY VAC 12-24" ST-90
19	1	8040751 ROD TIGHTENER WELD'T
20	1	T401125 REDUCER, 6MP-8FJ
21	2	T401120 ELBOW 90 6MP-8MJ
22	1	8048979 VALVE, UNLOADER BLUE W/SWITCH
23	1	T405030 PLUG, 1/4" MALE PIPE HEX HEAD
24	1	T401102 ELBOW 90 6MP-6MJ
25	1	8047724 SWITCH, FLOW 4KSI, 3/8"FNPT
26	1	T401020 ELBOW 90 6MP 6MP
27	1	8041785 HOSE ASSY VAC 6-18" ST-ST
28	1	T401160 ELBOW 90 12MP-8MJ
29	1	T400100 UNION 12MP-12MJ

* 2 8045875 BELT, AX 41 (31HP)

WATER PUMP ASSEMBLY

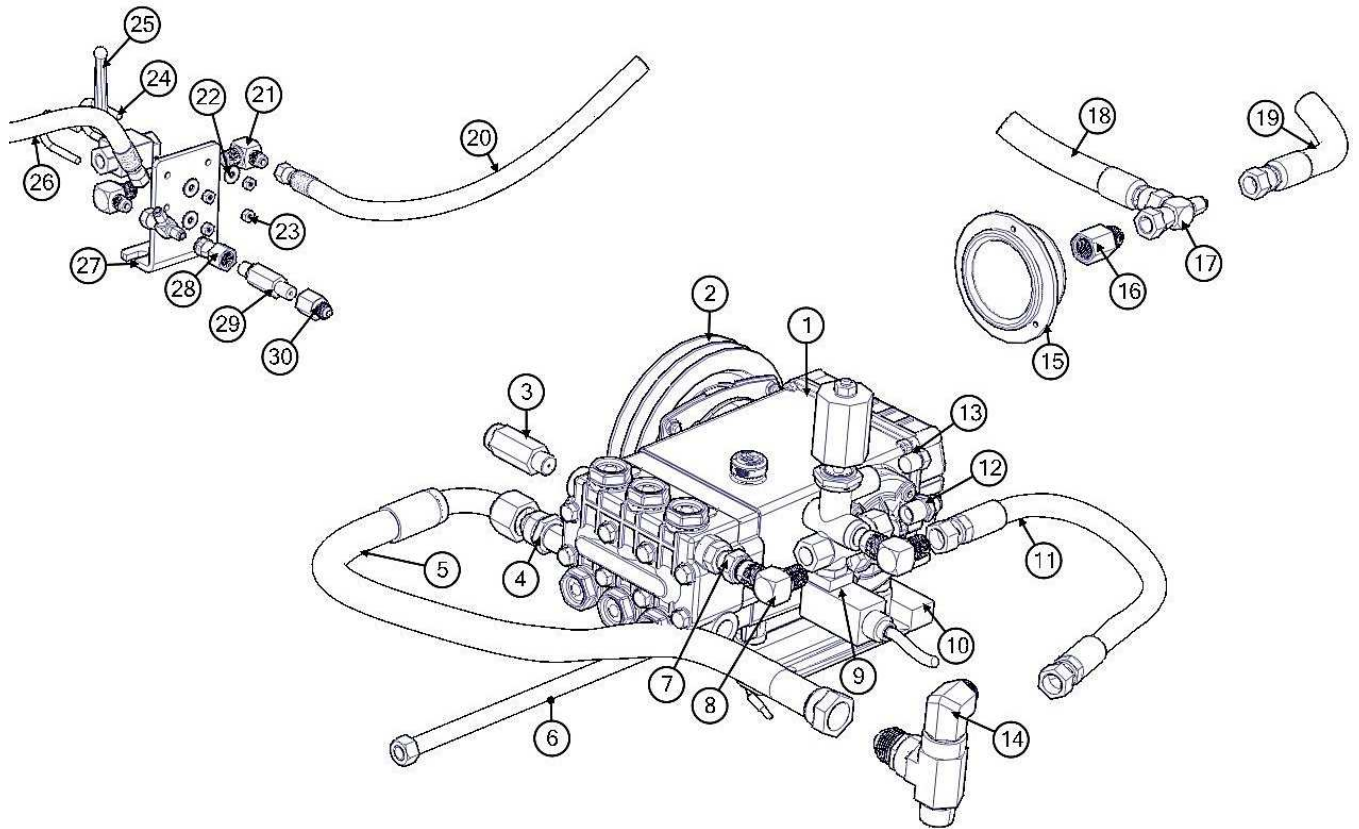

WATER PUMP ASSEMBLY

BOM ID	Qty	Description
1	1	8031279 PUMP, WATER
2	1	8030961 CLUTCH, WATER PUMP
3	1	8030340 SAFETY RELIEF VALVE 6GPM
4	1	T400070 REDUCER 12MJ-8MP
5	1	8049365 HOSE ASSY VAC 12-24" ST-90
6	1	8040751 ROD TIGHTENER WELD'T
7	1	T401125 REDUCER, 6MP-8FJ
8	2	T401120 ELBOW 90 6MP 8MJ
9	1	8048979 VALVE, UNLOADER BLUE W/SWITCH
10	1	8040893 BLOCK, WATER PUMP TENSION
11	1	8041785 HOSE ASSY VAC 6-18" ST-ST
12	1	T400028 ADAPTER STR -6MP -6MJ
13	1	T405030 PLUG, 1/4" MALE PIPE, HEX HEAD
14	1	T401160 ELBOW 90 12MP 8MJ
15	1	8030372 GAUGE, WATER PRESSURE
16	1	8031126 REDUCER 4FP_6MJ
17	2	T402153 TEE, 6FJ_6MJ_6MJ
18	1	8092787 HOSE ASSY VAC 6-124" ST-ST
19	1	8046818 HOSE ASSY VAC 6-54" ST-ST
20	1	8042178 HOSE ASSY VAC 6-155" ST-90
21	2	T401102 ELBOW 90 6MP_6MJ
22	4	U200020 WASHER, FLAT .250 ZP
23	4	U100020 NUT, HEX .25-20
24	2	U010017 CLAMP HOOK, 1 1/2" 1/4-20 THD
25	1	8030351 VALVE, BALL 3/8"NPT
26	1	8041152 HOSE ASSY VAC 6-29" ST-ST
27	1	8040670 BRACKET, BALL VALVE
28	1	T400083 UNION 6FP_6FJ
29	1	8030923 FILTER, WATER HIGH PRESSURE
30	1	T400031 UNION 6MJ_6FP

* 2 8045875 BELT, AX 41 (31HP)

Water Pump TS2021

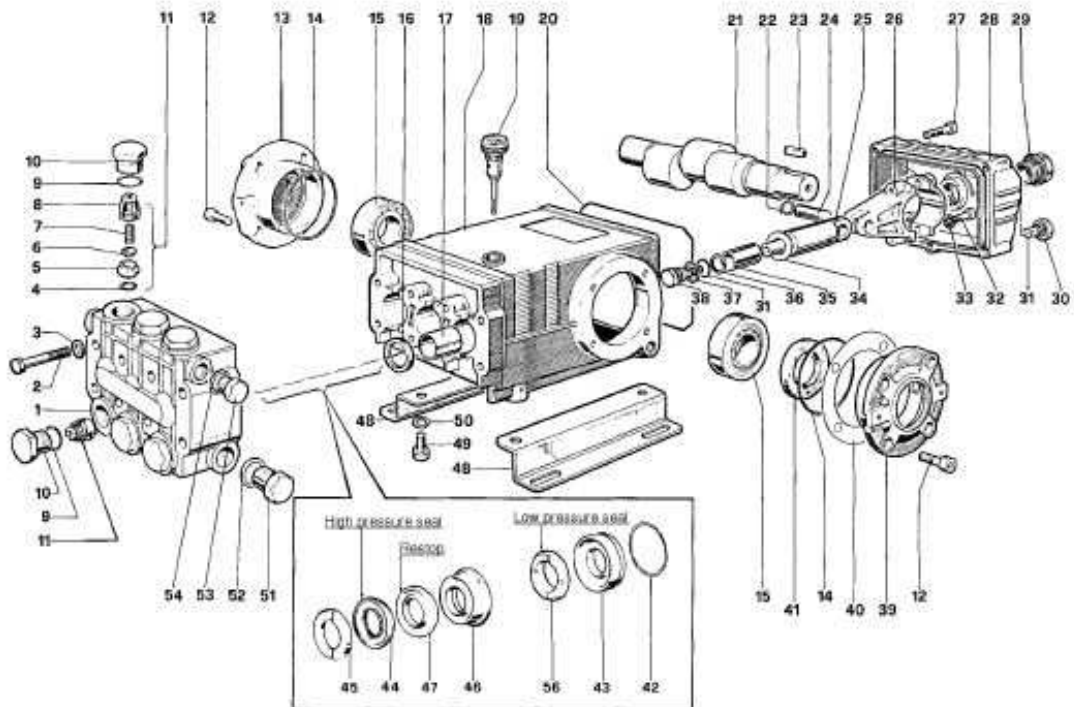

TORQUE SPECS*

*Decrease torque by 20%
if threads are lubricated

Position	Ft. Lbs.	N-M
2	22.1	29.9
10	73.7	99.9
12	14.7	19.2
27	7.3	9.9
29	13.2	17.9
30	14.7	19.2
32	14.7	19.2
38	14.7	19.2
49	29.4	39.8
51	29.4	39.8
53	29.4	39.8

Water Pump TS2021

ITEM	QTY.	PART #	DESCRIPTION	KIT#	ITEM #'S INCL'D IN KIT	NO. OF ASSY IN KIT	NO. OF CYL KIT WILL SERVICE
1	1	8031280-1	Manifold	8031280-KIT1	4, 5, 6, 7, 8 (11)	6	3
2	8	8031280-2	Screw, M8 x 70	8031280-KIT2	16	3	3
3	8	8031280-3	Washer, M8 x 4	8031280-KIT3	41	2	0
4	8	8031280-4	O-ring, .674 x .103	8031280-KIT4	9, 10	6	3
5	6	8031280-5	Seat, Valve	8031280-KIT5	9, 10	6	3
6	6	8031280-6	Plate, Valve	8031280-KIT6	31, 34	3	3
7	6	8031280-7	Spring		36, 37, 38		
8	6	8031280-8	Guide, Valve	8031280-KIT7	45	6	3
9	6	8031280-9	O-ring, 2.675 x .103	8031280-KIT10	42, 43	3	3
10	6	8031280-10	Cap	8031280-KIT28	42, 43, 44,	1	1
11	6	8031280-11	Valve Assembly		45, 45, 47, 56		
12	8	8031280-12	Screw, M8 x 16	8031280-KIT69	44, 47, 56	3	3
13	1	8031280-13	Cover, Crankcase	8031280-KIT71	46, 47	3	3
14	2	8031280-14	O-ring, 2.675 x .103				
15	2	8031280-15	Bearing, Roller				
16	3	8031280-16	Seal, Oil				
17	3	8031280-17	Bushing				
18	1	8031280-18	Crankcase				
19	1	8031280-19	Oil Dip Stick				
20	1	8031280-20	O-ring, Cover				
21	1	8031280-21	Crankshaft				
22	6	8031280-22	Ring, Snap				
23	1	8031280-23	Key				
24	3	8031280-24	Pin, Wrist				
25	3	8031280-25	Guide, Plunger				
26	3	8031280-26	Rod, Connecting				
27	5	8031280-27	Screw, M6 x 30				
28	1	8031280-28	Cover, Crankcase				
29	6	8031280-29	Oil Indicator				
30	1	8031280-30	Cap				
31	4	8031280-31	O-ring, 4.26x.070				
32	6	8031280-32	Screw, M8 x 35				
33	6	8031280-33	Washer, M8.4				
34	3	8031280-34	Washer, M14				
35	3	8031280-35	Plunger (20 mm)				
37	3	8031280-37	Washer				
38	3	8031280-38	Screw, Plunger				
39	1	8031280-39	Cover, Crankcase				
40	2	8031280-40	Shim				
41	1	8031280-41	Seal, Oil				
42	3	8031280-42	O-ring, 1.364x.070				
43	3	8031280-43	Retainer, Packing				
44	3	8031280-44	Packing				
45	3	8031280-45	Ring, Head, M20				
46	3	8031280-46	Intermed. Ring				
47	3	8031280-47	Testop Ring				
48	2	8031280-48	Pump Feet				
49	4	8031280-49	Screw, M10 x 18				
50	4	8031280-50	Washer, M10.2				
51	1	8031280-51	Cap				
52	1	8031280-52	Washer, M21.5				
53	1	8031280-53	Cap				
54	1	8031280-54	Washer, M17.5				
56	3	8031280-56	Seal, Low Press, 20mm				

ANTIFREEZE ASSEMBLY

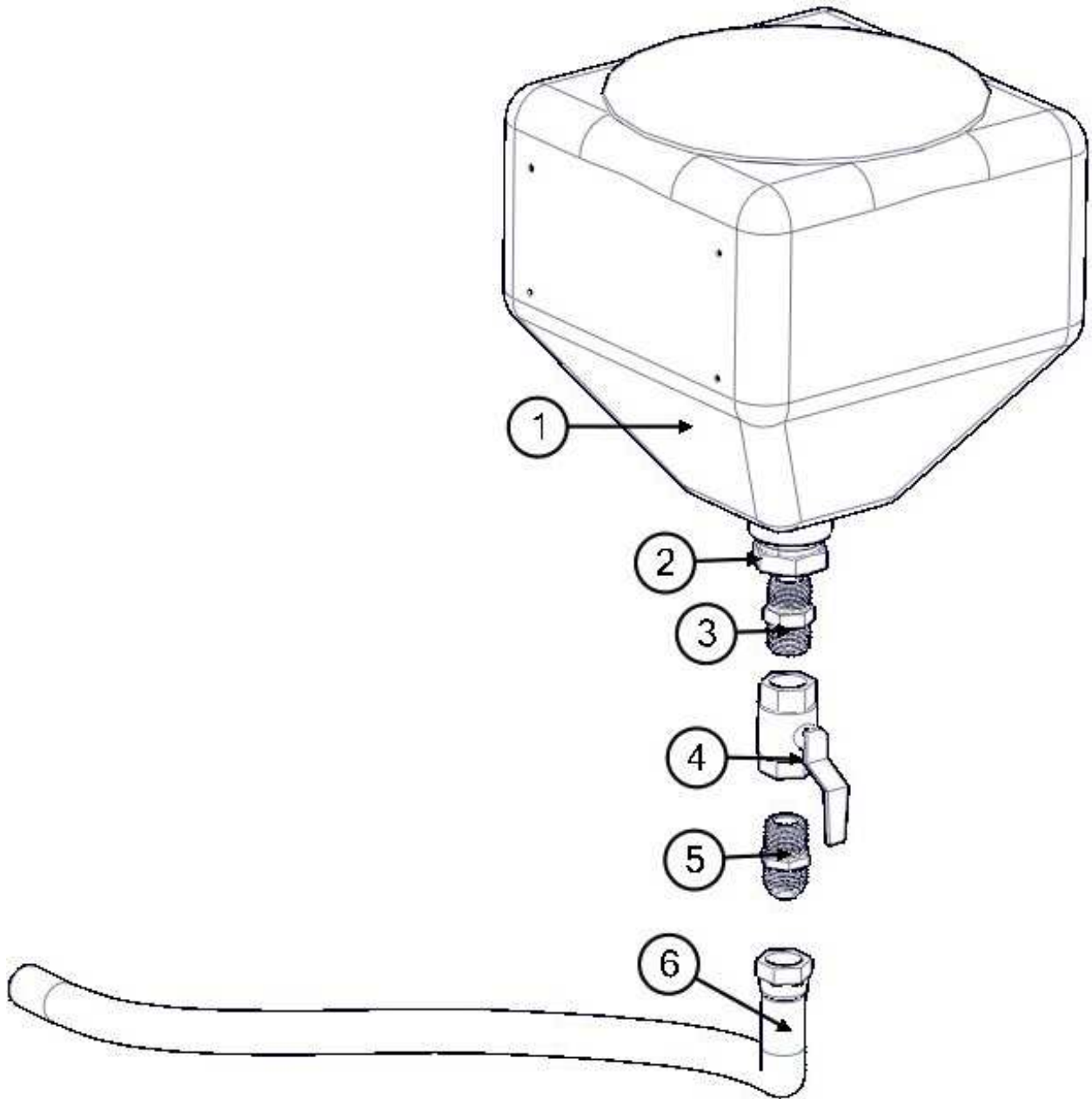

ANTIFREEZE ASSEMBLY

BOM ID	Qty	Name
1	1	8030394 TANK,ANTIFREEZE 4 GALL W_CAP
2	1	T403100 REDUCER 20MP-12FP
3	1	T400800 UNION 12MP-12MP
4	1	T000185 VALVE, BALL 3/4" FNPT BRASS
5	1	T400100 UNION 12MP_12MJ
6	1	8041058 HOSE VAC PUSH 12-36"

SPOIL TANK ASSEMBLY

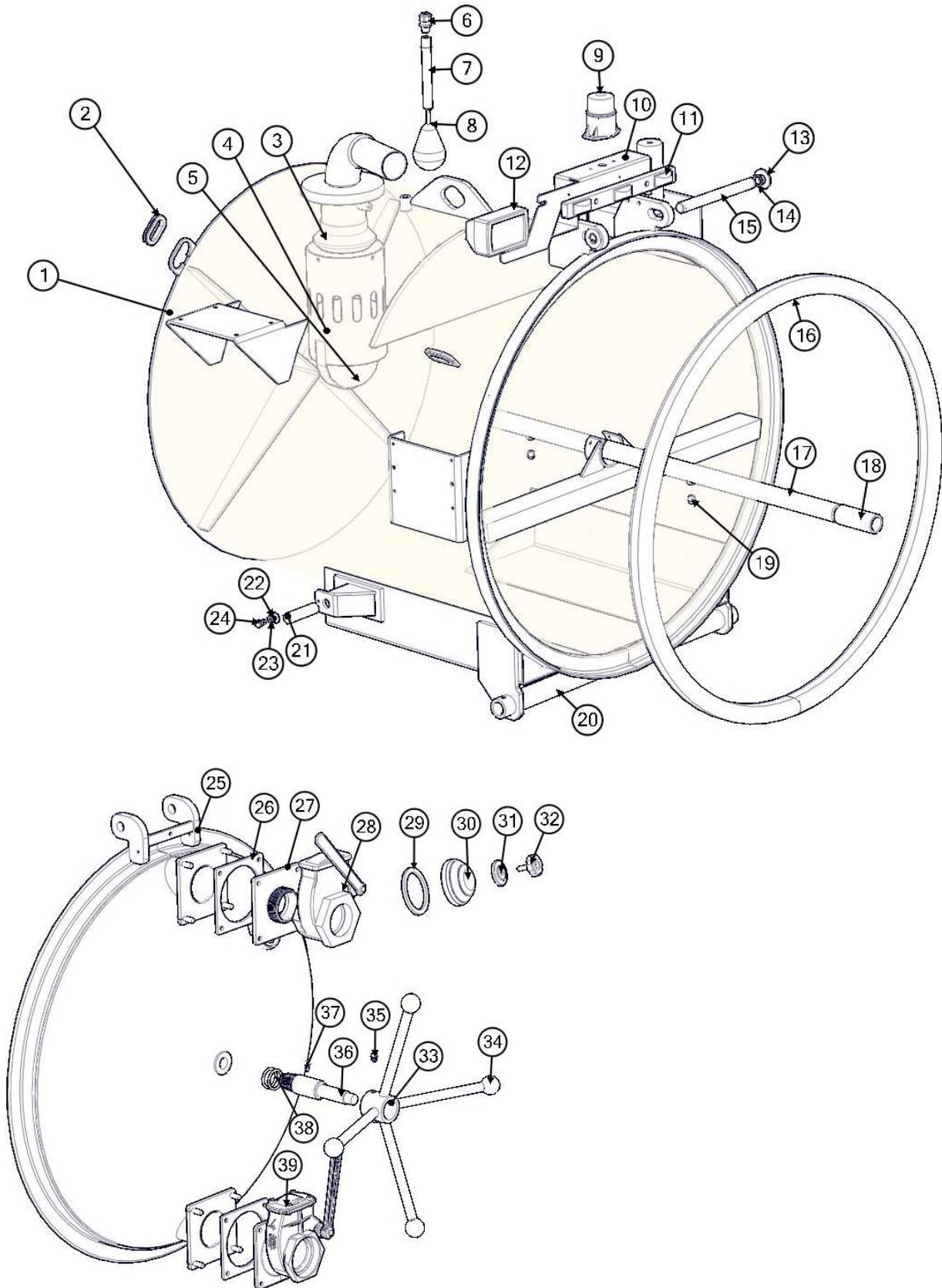

SPOIL TANK ASSEMBLY

BOM ID	Qty	Name
1	1	8045775 TANK, WELDMENT 250
2	2	8042812 GROMMET, 2"ID X 3"OD X 1/4"WOG
3	1	8043571 SEAT, RUBBER 4" for FLOAT BALL
4	1	8043700 WELDMENT, BALL FLOAT SHUTOFF
5	1	8043570 BALL, STAINLESS FLOAT 6"
6	1	X000113 STRAIN RELIEF, 1/2"
7	1	8040769 TUBE, HIGH LEVEL FLOAT SWITCH
8	1	8030531 SWITCH, HIGH LEVEL FLOAT
9	1	8043139 LIGHT, STROBE
10	1	8047253 STROBE LIGHT BRACKET 250 (STRONGARM)
11	1	8041509 LIGHT, CLEARANCE 3 BAR
12	1	8043138 LIGHT, WORK
13	2	8030171 WASHER, DOOR HINGE
14	2	8030362 SNAP RING, 1"
15	1	8040759 ROD, HINGE
16	1	8041765 SEAL, TANK DOOR 250
17	1	8040610 ROD, TANK
18	1	8040202 FIRESTICK, FEMALE Q.L.
19	2	8030369 NOZZLE, TANK CLEANOUT
20	1	8042648 TUBE, TANK PIVOT
21	2	8040753 CYLINDER PIN WELDMENT VX250 TANK
22	2	U200060 WASHER, FLAT .375 ZP
23	2	U210060 WASHER, LOCK .375 ZP
24	2	U000400 SCREW, HC .375-16
25	1	8045777 WELDMENT, DOOR 250
26	2	8046191 GASKET, INLET/OUTLET DOOR LE
27	1	8046197 GATE VALVE TANK FLANGE 3"
28	1	8042408 VALVE, GATE 3"
29	1	8032007 GASKET, COUPLER 4"
30	1	8031048 SIGHT GLASS
31	1	8031047 PLATE, SIGHT GLASS
32	1	8031046 HAND WHEEL, SIGHT GLASS
33	1	8040235 HANDLE, DOOR 250
34	4	J400060 KNOB, 1 7/8"
35	2	U010040 SCREW, HSH .312-18 X .500
36	1	8040306 STRIKER, DOOR Q.L.
37	1	T500080 FITTING, GREASE 3/16"
38	2	W200120 O-RING 1 7_8 X 2 1_8 X 1_8 (225)
39	1	8046215 VALVE, GATE 4"

* NOT SHOWN

* 1 8041585 COUPLING, PP 3"FCAM X 3"MNPT

FILTRATION ASSEMBLY

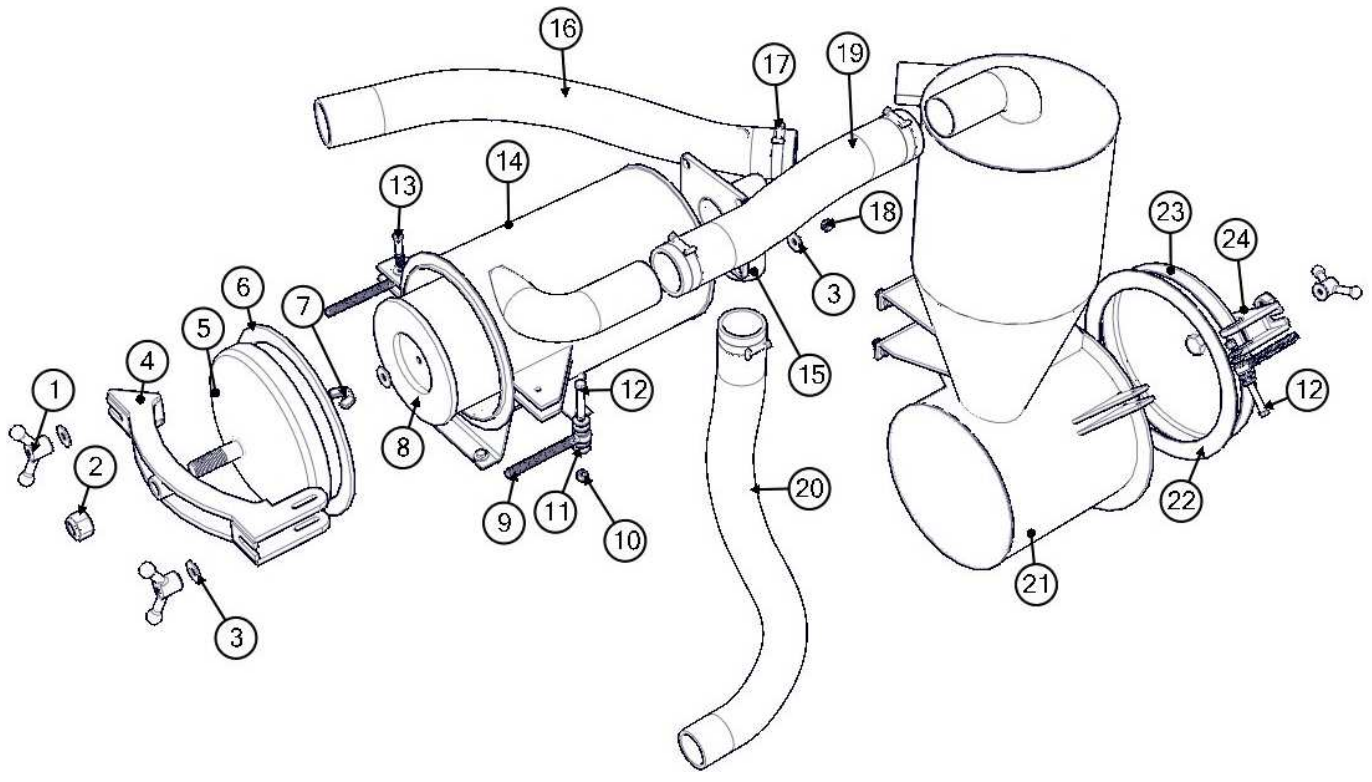

FILTRATION ASSEMBLY

BOM ID	Qty	Name
1	4	8041594 HANDLE, WING 1/2"-13
2	2	U120060 NUT, LOCK NY 1"-8
3	6	U200100 WASHER, FLAT 1/2" ZP
4	1	8044622 DOOR LATCH WELDMENT
5	1	8044620 575 RF AIR FILTER DOME (DOOR) ASSEMBLY
6	1	8044819 GASKET, REV FLOW AIR FILTER
7	1	U130080 NUT,WING .500-13 ZP G2
8	1	8031178 FILTER,AIR WASHABLE 575CFM
9	4	8041593 BOLT,EYE 1_2-13 X 6
10	10	U120110 NUT, LOCK 3/8"-16 NY ZP
11	36	U200060 WASHER, FLAT 3/8" ZP
12	2	U000580 SCREW,HC .375-16 X 3.50 ZP G5
13	2	U000520 SCREW,HC .375-16 X 2.25 ZP G5
14	1	8046337 FILTER HSG AIR 575 RF
15	1	8046881 ELBOW 3in FLANGE WELDMENT
16	1	8043940 TANK TO CYCLONE HOSE KANAFLEX 3-48"LG
17	4	8042605 CLAMP, HOSE T-BOLT 350
18	4	U120132 NUT, LOCK 7/16"-14 NY
19	1	8043939 AIR FILTER TO CYCLONE HOSE KANAFLEX 3-20"
20	1	8043938 AIR FILTER TO BLOWER HOSE KANAFLEX 3-126"
21	1	8044589 CYCLONE HOUSING 575 RF
22	1	8041612 GASKET, REV FLOW CYCLONE
23	1	8041402 DOME, CYCLONE REV FLOW
24	1	8041552 LATCH, CYCLONE DOME

TOOL RACK ASSEMBLY

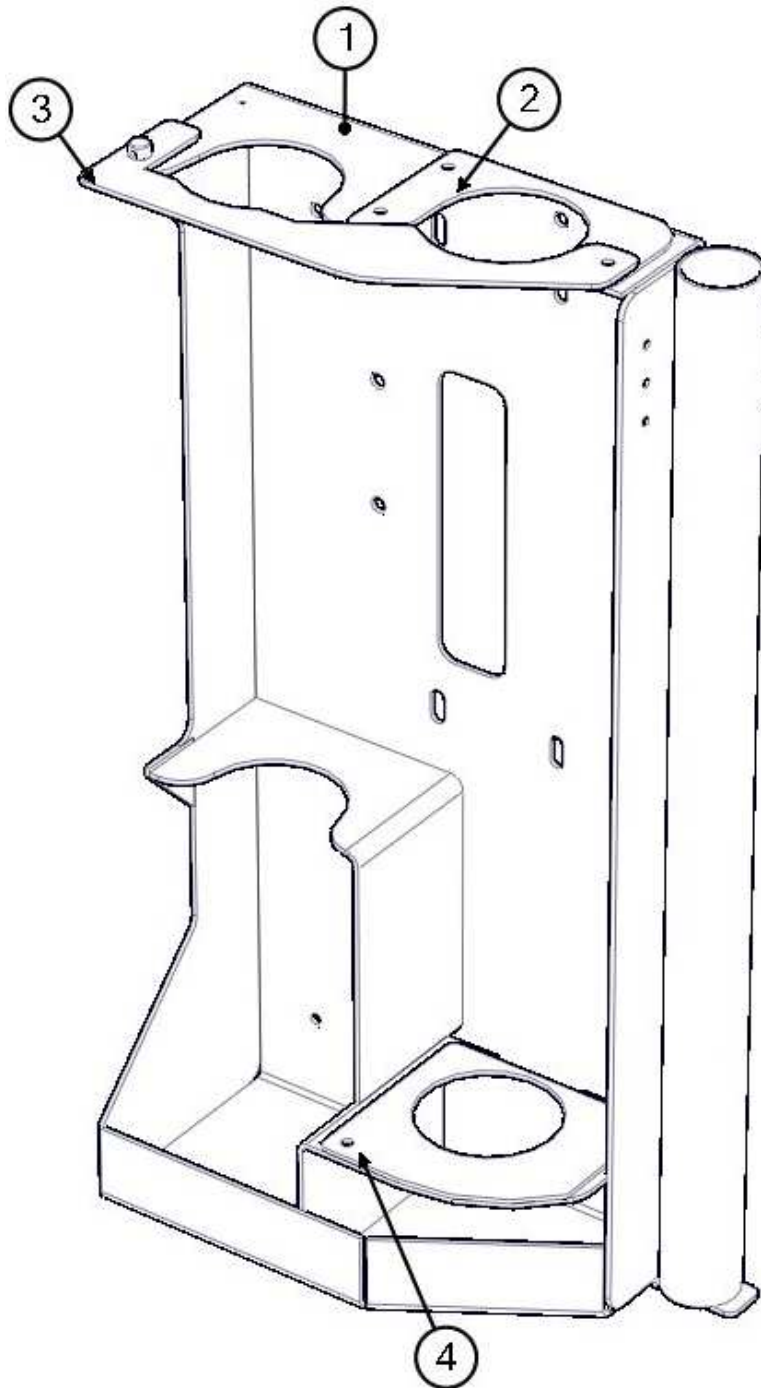

TOOL RACK ASSEMBLY

BOM ID	Qty	Name
1	1	8040985 TOOL RACK WELDMENT
2	1	8045610 TOP INSERT 3", TOOL RACK
3	1	8040884 TOOL RACK CLOSURE
4	1	8045609 BOTTOM INSERT, TOOL RACK

NOT SHOWN:

1 R700175 R-CLIP 7/8"
1 8041259 STRAP, 10"
1 8041485 LANYARD CABLE
1 8041244 PIN, CLEVIS 1/2"DIA. 3/4"

HOSE ASSEMBLY

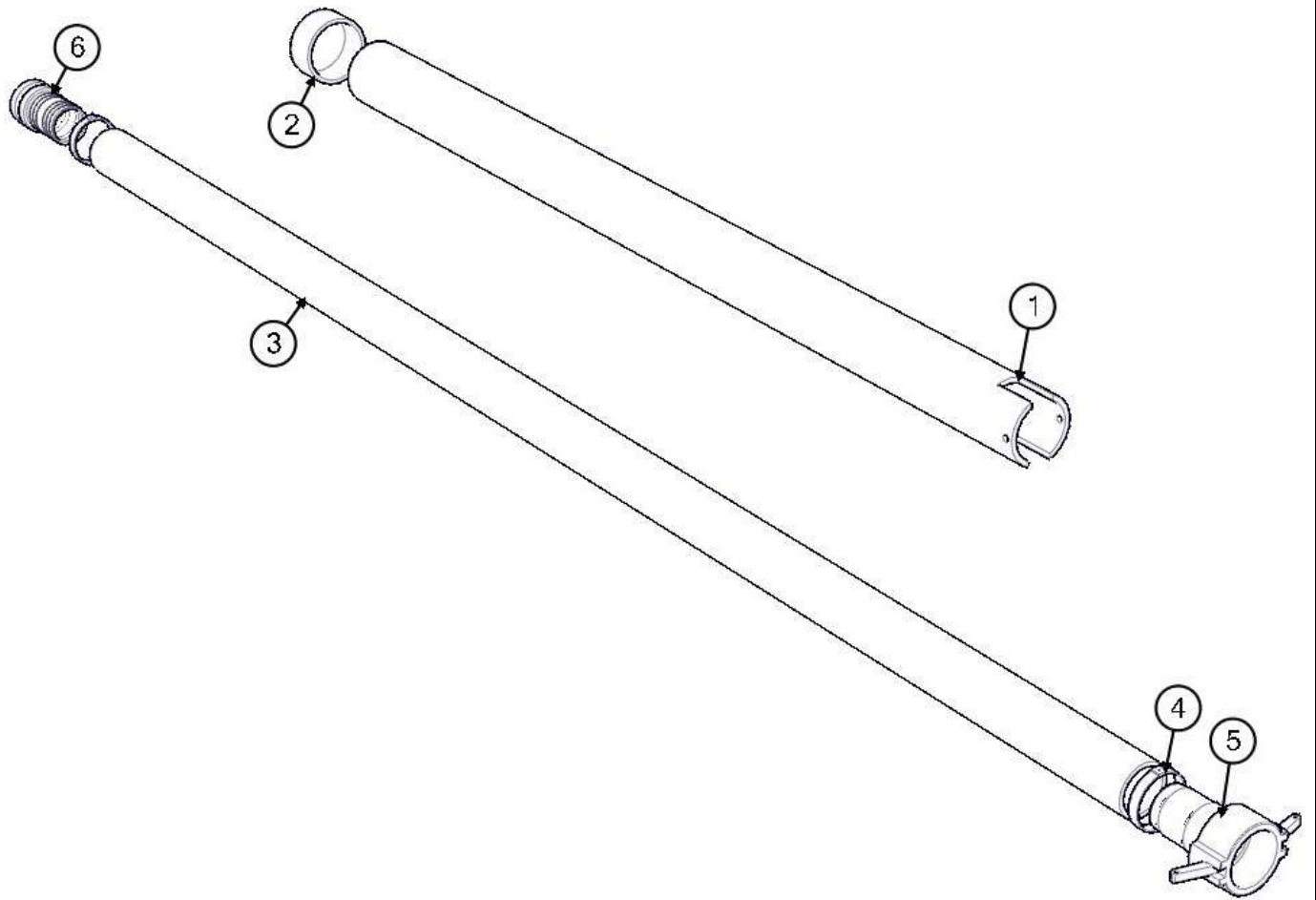

HOSE ASSEMBLY

BOM ID	Qty	Name
1	1	8041111 TUBE, PVC 4" STORAGE 10'LG
2	1	8030435 END CAP 4"
3	1	8040338 HOSE VAC KANAFLEX 3-110"
4	2	8030356 CLAMP, 4IN PUNCHLOCK P16-S
5	1	8046441 CAMLOCK, 3"AL FCAM X MBARB
6	1	8046440 CAMLOCK, 3"AL MCAM X MBARB

NOT SHOWN:

1 8041485 LANYARD CABLE
1 8043198 CLAMP, HOSE STORAGE
1 8041101 ROD, HOSE STORAGE RETAINING
1 R700170 R-CLIP, 1/2"-5/8 SHANK

3" SUCTION TOOL ASSEMBLY

SUCTION TOOL COMPLETE - 8030215

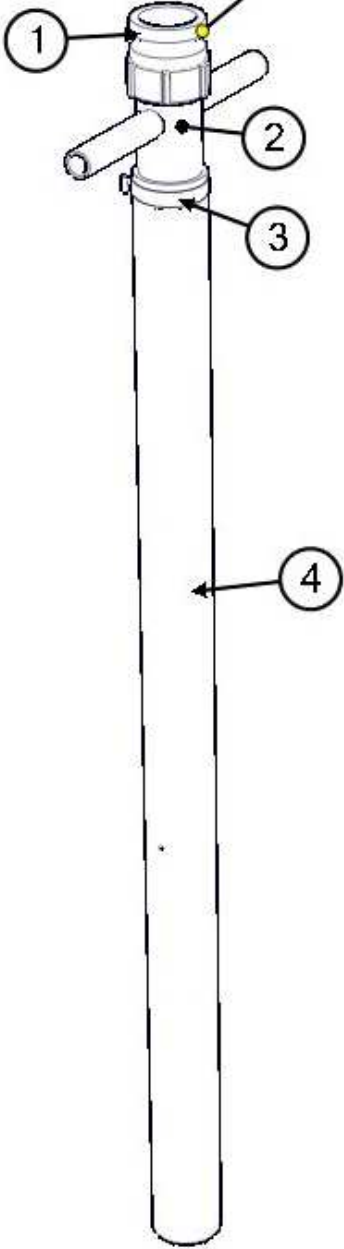

3" SUCTION TOOL ASSEMBLY

BOM ID	Qty	Name
1	1	8030391 COUPLING, 3"BANJO M X FM
2	1	8030317 VACUUM TOOL HANDLE 3 INCH
3	1	8030356 CLAMP, 4" PUNCHLOCK P16-S
4	1	8030313 TUBE, VACUUM PVC 3"

3" REDUCTION TOOL ASSEMBLY

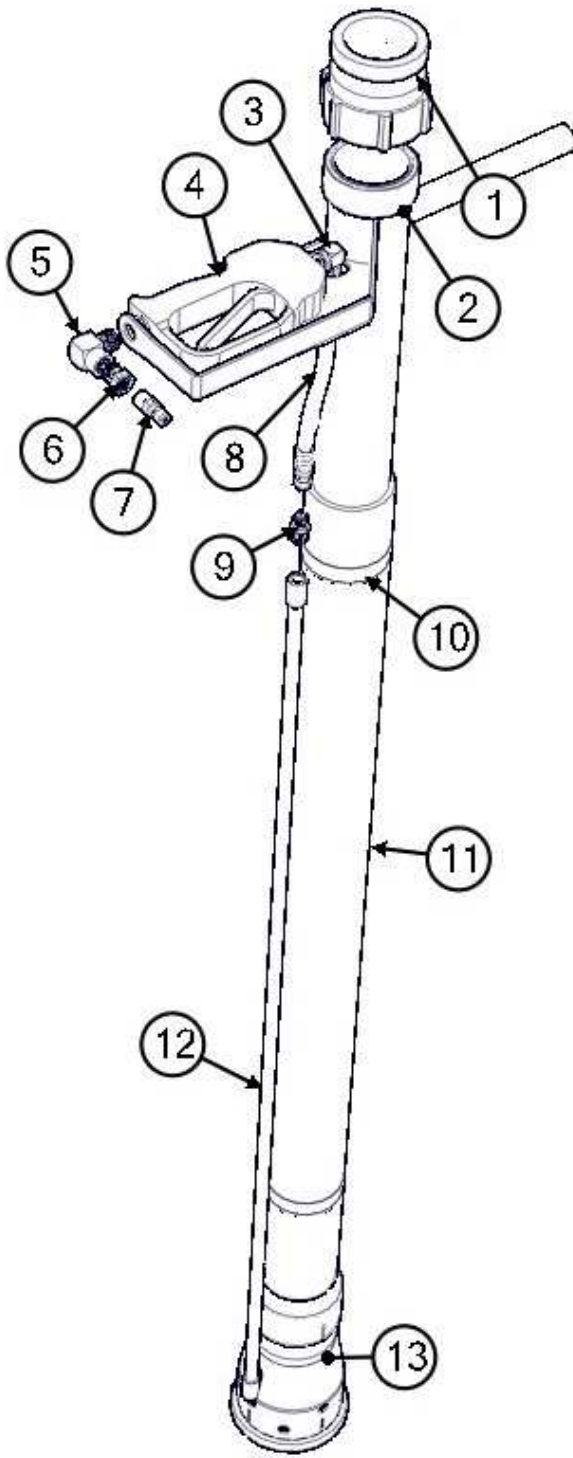

3" REDUCTION TOOL ASSEMBLY

BOM ID	Qty	Name
1	1	8030391 BANJO, 3" MALE 3" FNPT
2	1	8042862 REDUCTION TOOL HEAD
3	1	T401100 ELBOW 90 4MP_4MJ
4	1	8048567 GUN, SPRAY STRAIGHT
5	1	T401065 ELBOW 90 6MP 6FP
6	1	T400023 REDUCER 6MP_4FP
7	1	8030486 WATER QD 1/4"MNPT SS
8	1	8031248 HOSE ASSEMBLY REDUCTION TOOL
9	1	T400020 UNION 4MP 4MJ
10	2	8042605 CLAMP, HOSE T-BOLT 350
11	1	8042811 TUBE, PVC 3" X 48" VAC REDUCTION
12	1	8043764 TUBE, CHROME WATER SUPPLY 1/4"NPT
13	1	8030627 REDUCTION TOOL BOT WELDMENT

WASH WAND TOOL ASSEMBLY

8091356 - QUICK DISCONNECT, MALE 3/8
MUST ORDER SEPARATELY

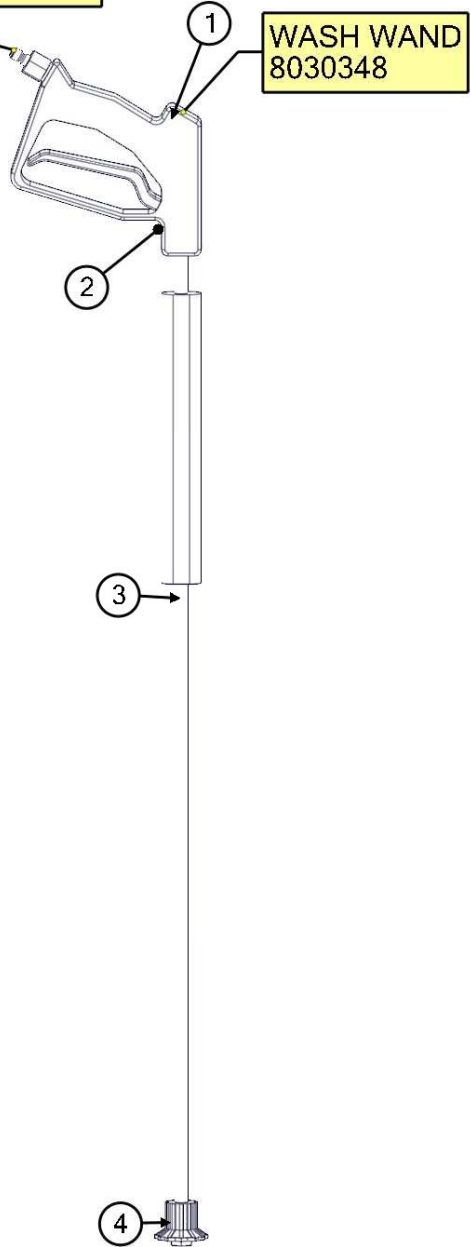

WASH WAND
8030348

WASH WAND TOOL ASSEMBLY

BOM ID	Qty	Name
1	1	8030348 WAND COMPLETE
2	1	8030928 TRIGGER ASSEMBLY
3	1	8030847 WAND
4	1	8031303 NOZZLE, #10 40DEG

* NOT SHOWN

1 8092777 ROD RETAINING ASSEMBLY, TOOL STORAGE

ROTARY LANCE TOOL ASSEMBLY

8091356 - QUICK DISCONNECT, MALE 3/8
MUST ORDER SEPARATELY

ROTARY LANCE
8043119

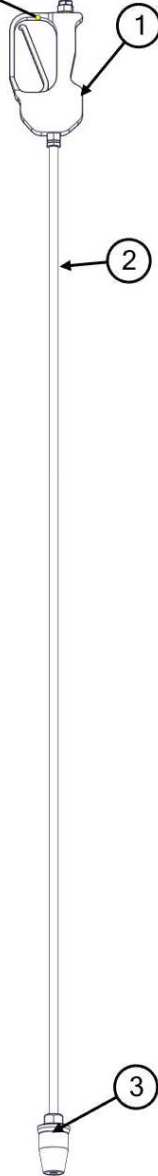

ROTARY LANCE TOOL ASSEMBLY

BOM ID	Qty	Name
1	1	8048567 GUN, SPRAY STRAIGHT
2	1	8043765 TUBE, CHROME 1/4NPT 60"LG
3	1	8048739 NOZZLE, ROTATING 055
4	1	8091384 STORAGE, TOOL PVC 2 1/2" X 72'LG

* NOT SHOWN

8092777 ROD RETAINING ASSEMBLY, TOOL STORAGE

VALVE BOX TOOL ASSEMBLY

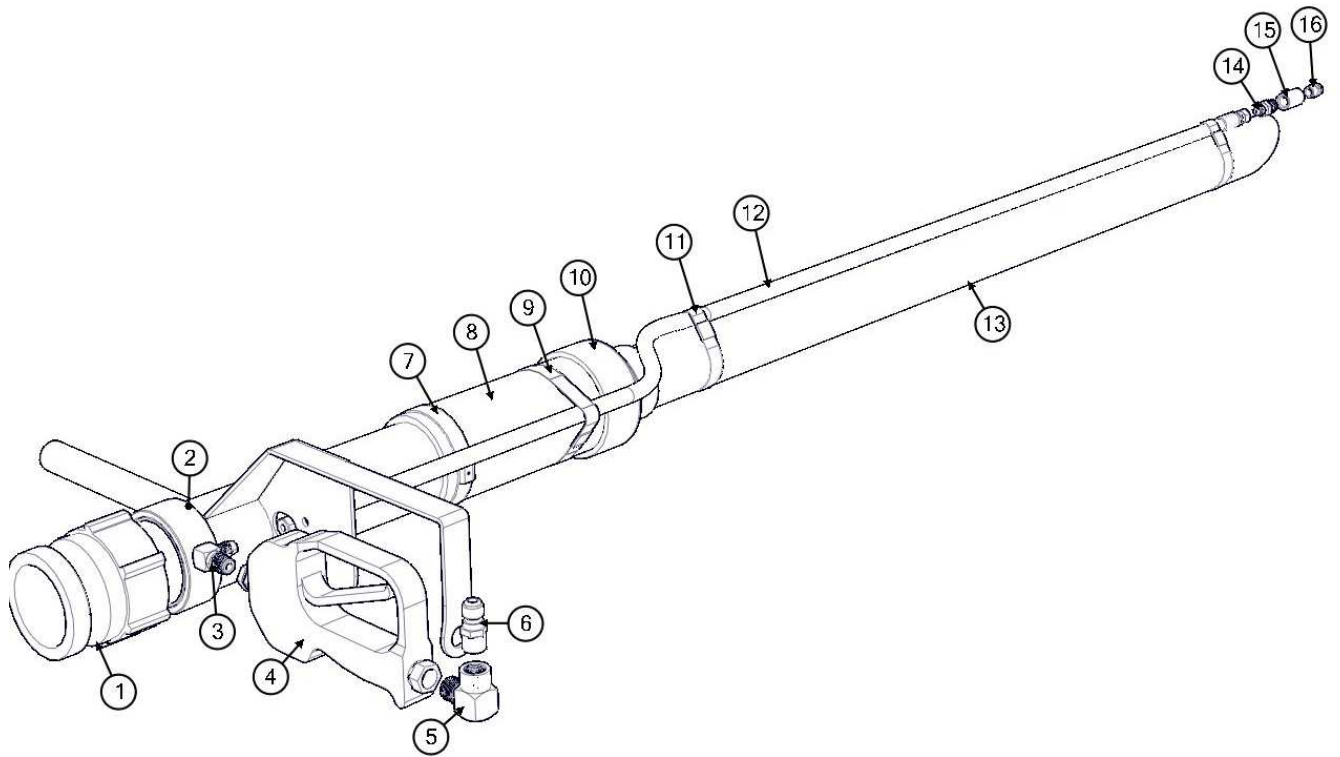

VALVE BOX TOOL ASSEMBLY

BOM ID	Qty	Name
1	1	8030391 BANJO, 3" MALE FNPT
2	1	8042862 REDUCTION TOOL HEAD
3	1	T401100 ELBOW 90 4MP_4MJ
4	1	8048567 GUN, SPRAY STRAIGHT
5	1	T401065 ELBOW 90 6MP_6FP
6	1	8091356 QUICK DISCONNECT 3 8 MALE
7	1	8042605 CLAMP, HOSE T-BOLT 350
8	1	8044096 TUBE, PVC 3"DIA X 9"LG
9	1	8042855 CLAMP, HOSE T-BOLT 375
10	1	8030669 REDUCER, PVC 3" TO 2" SLIP ON
11	2	8045316 CLAMP, HOSE T-BOLT 275
12	1	8044098 HOSE ASSY VALVE BOX CLEANOUT TUBE
13	1	8044097 TUBE, PVC 2"DIA X 42.5"LG
14	1	T400020 UNION 4MP_4MJ
15	1	T422010 COUPLING, 1/4"FP
16	1	8031246 NOZZLE .100 X 0 DEG

LAWN SWEEPER TOOL ASSEMBLY

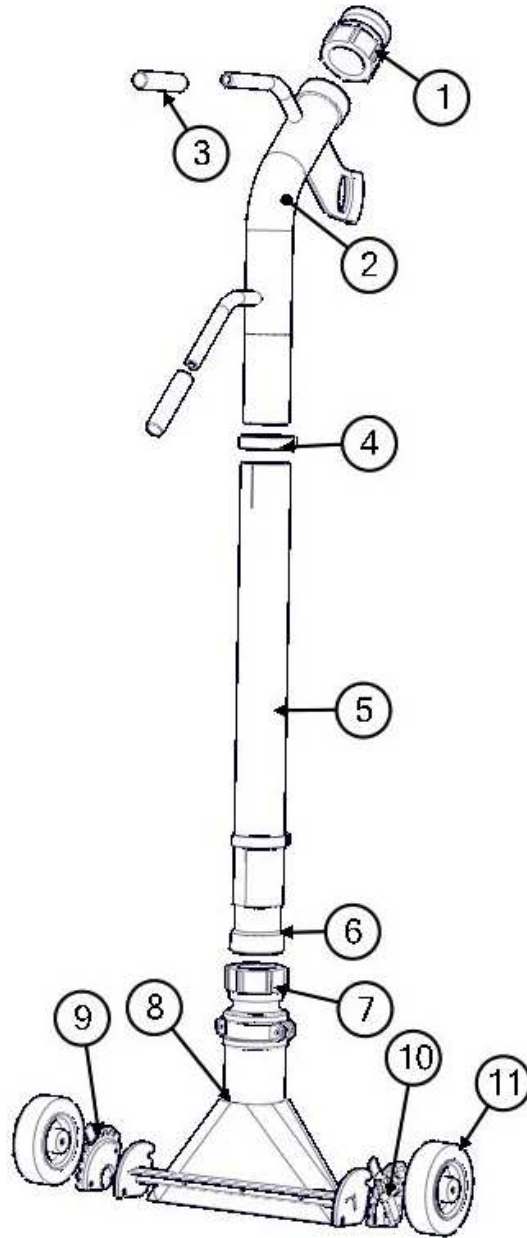

LAWN SWEEPER TOOL ASSEMBLY

Description	BOM ID	Qty
8030287 ADAPTER, 3"HOSE X 3"MNPT	6	1
8030391 BANJO, 3"MALE 3"FNPT	1	1
8030391 BANJO, 3"MALE 3"FNPT	7	1
8042605 CLAMP, HOSE T-BOLT 3"	4	2
8043887 WHEEL, 6" PNEUMATIC	11	2
8043925 DUCKBILL 3" ALUMINUM	8	1
8043931 LEFT WHEEL ADJUSTER	10	1
8043931 RIGHT WHEEL ADJUSTER	9	1
8043932 PVC, 3" X 30"	5	1
8043933 WELDMENT, LAWN SWEEPER	2	1
J300080 HANDLE GRIP	3	2

ARROWBOARD OPTION

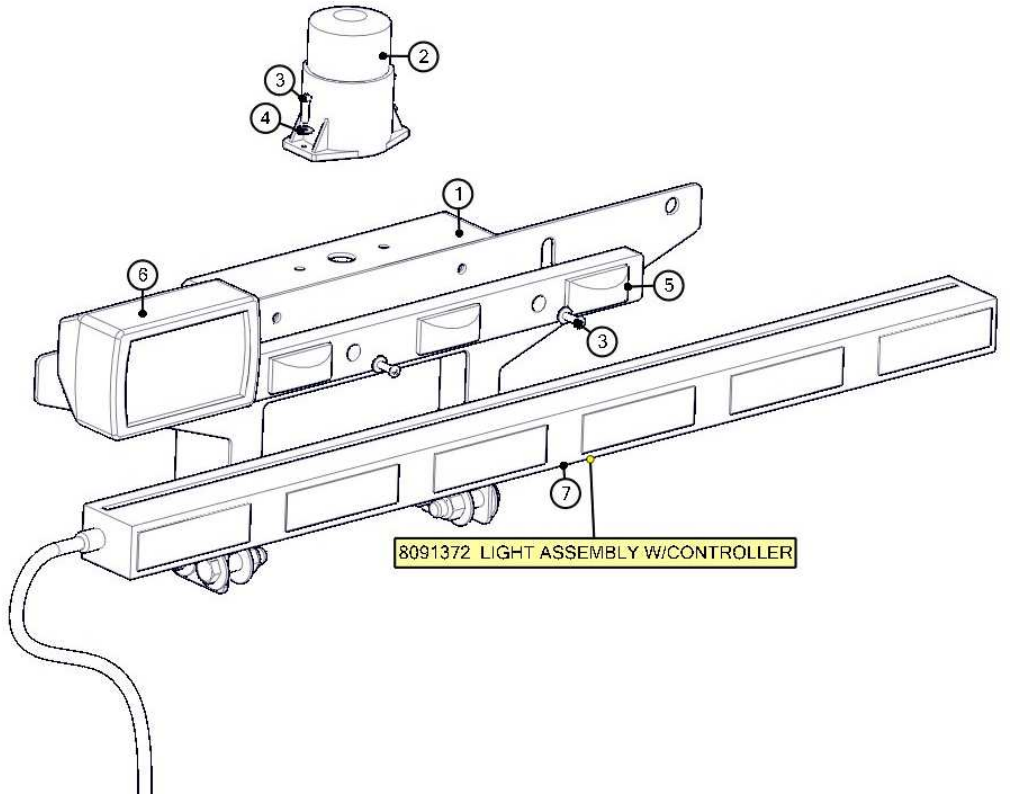
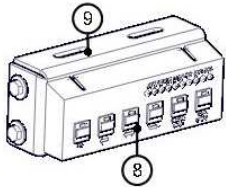

ARROWBOARD OPTION

BOM ID	Qty	Description
1	1	8093904 WELDMENT, BRACKET LIGHT DIRECTIONAL
2	1	8043139 LIGHT, STROBE LED DEUTSCH
3	4	U030809 SCREW, PAN HD PHIL 10-24 X .75
4	8	U200001 WASHER, FLAT #10
5	1	8041509 LIGHT, TANK CLEARANCE 3 BAR
6	1	8043138 LIGHT, WORK VAC TRAP DEUTSCH
7	1	8093911 LIGHT, DIRECTIONAL LED FRONT (NO CONTROLS)
8	1	8091372-1 CONTROLLER, TRAFFIC ARROW
9	1	8093926 CONTROLLER MOUNT

STRONGARM OPTION

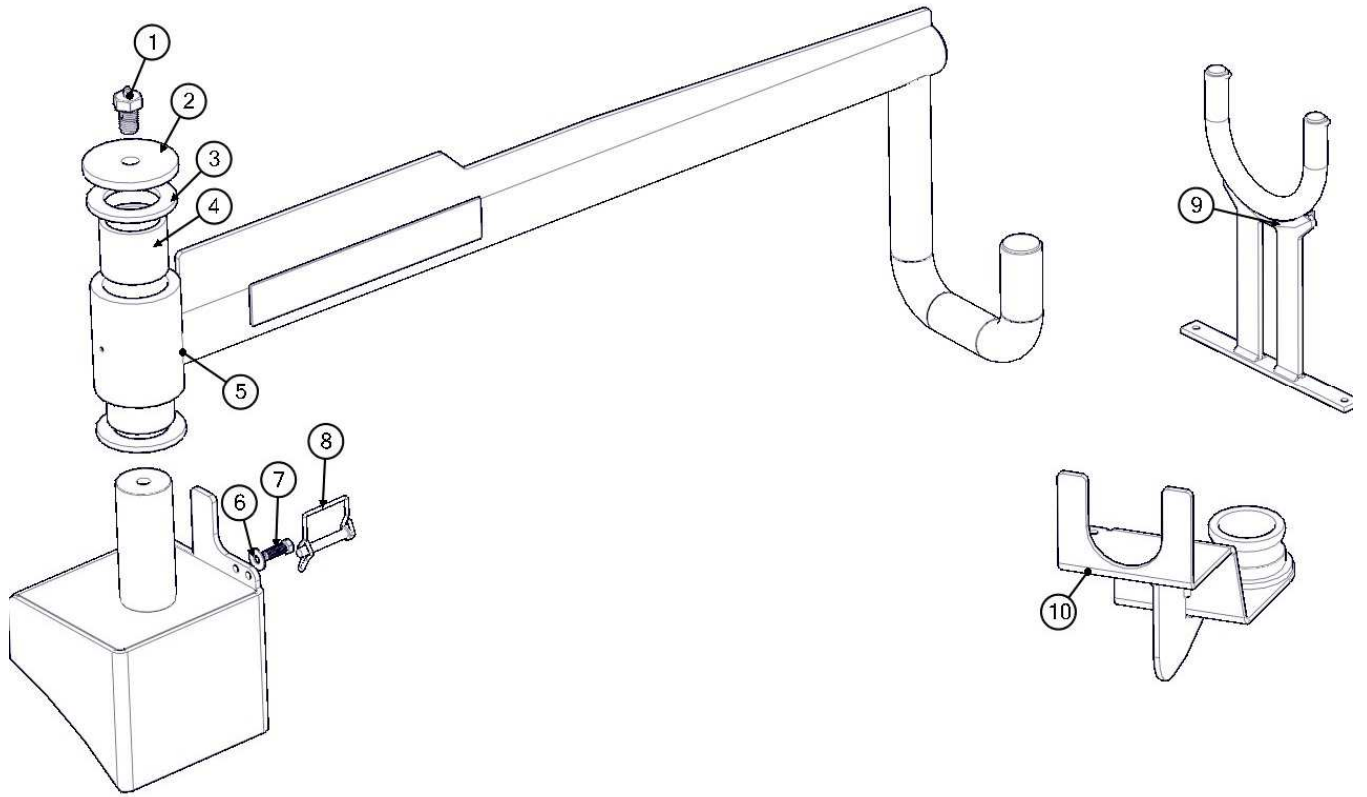

STRONGARM OPTION

BOM ID	Qty	Name
1	1	8048195 SCREW,HC .750-10X1.25 ZP G5 W GREASE FITTING
2	1	8047085 END CAP, SA BOX
3	2	8047077 WEAR FLANGE, PIVOT ARM MOUNT
4	2	8047076 PIVOT BUSHING, STRONGARM
5	1	8048710 STRONG ARM V250 - ARM WELDMENT
6	1	J200114 DECAL, STRONGARM
7	1	U200060 WASHER, FLAT 3/8"ZP
8	1	U000440 SCREW,HC 3/8-16 X 1.25" ZP G5
9	1	8041213 PIN, SAFETY 3/8"
10	1	8048770 BOOM - TALL END PIVOT WELDMENT
11	1	8048768 HOSE STORAGE BRACKET

REMOTE DRAIN OPTION

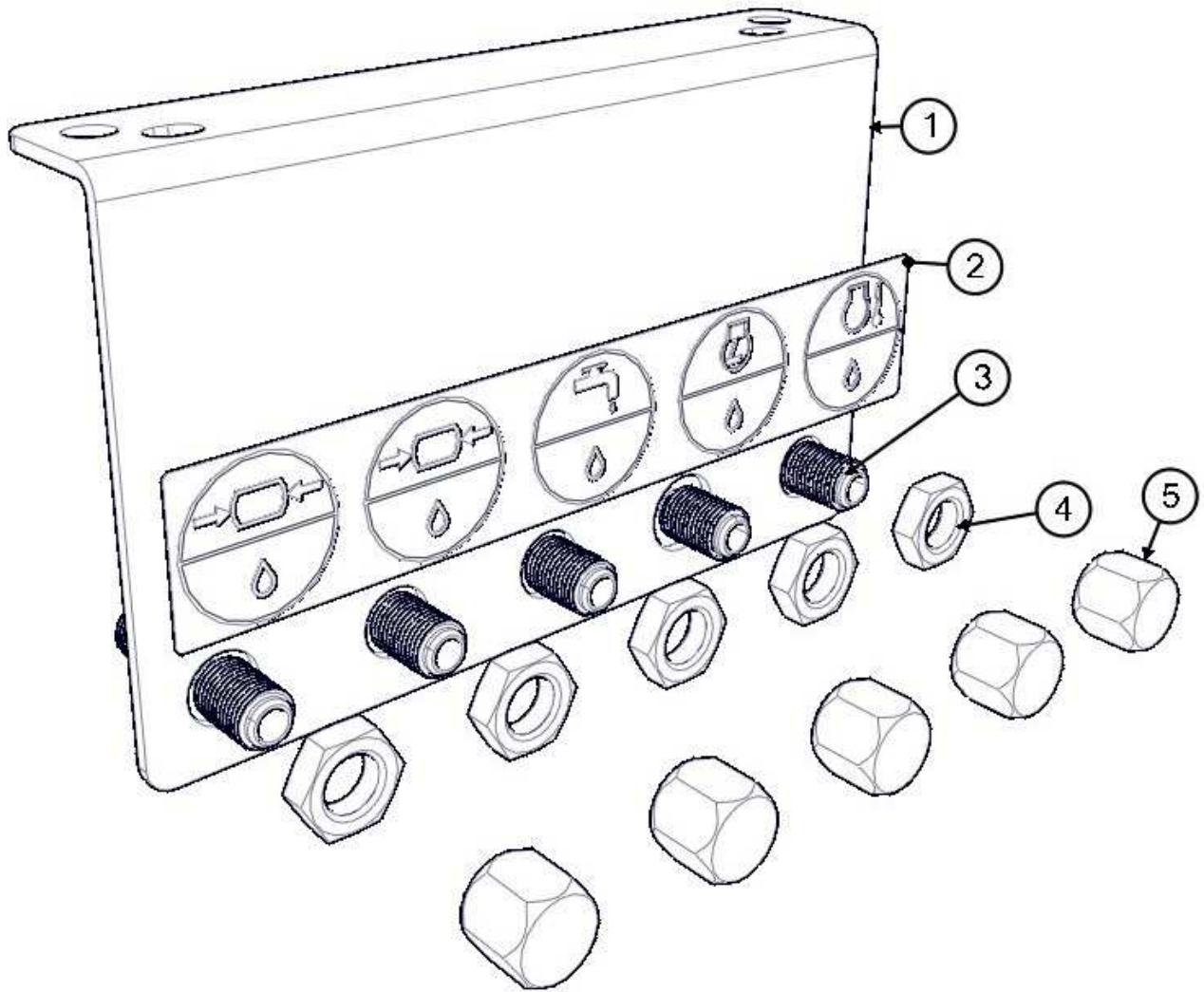

REMOTE DRAIN OPTION

BOM ID	Qty	Name
1	1	8043794 BRACKET, REMOTE DRAIN
2	1	J200032 DECAL, REMOTE DRAIN
3	5	T400391 BULKHEAD 6MJ_6MJ
4	5	T400391-1 NUT, LOCK BULK HEAD, 3_8 MJ-3_8 MJ
5	5	T405203 CAP, 3/8"FJIC

PAGE LEFT BLANK

Vacuum Diesel Engine Schematic

VACUUM DIESEL ENGINE SCHEMATIC

080108

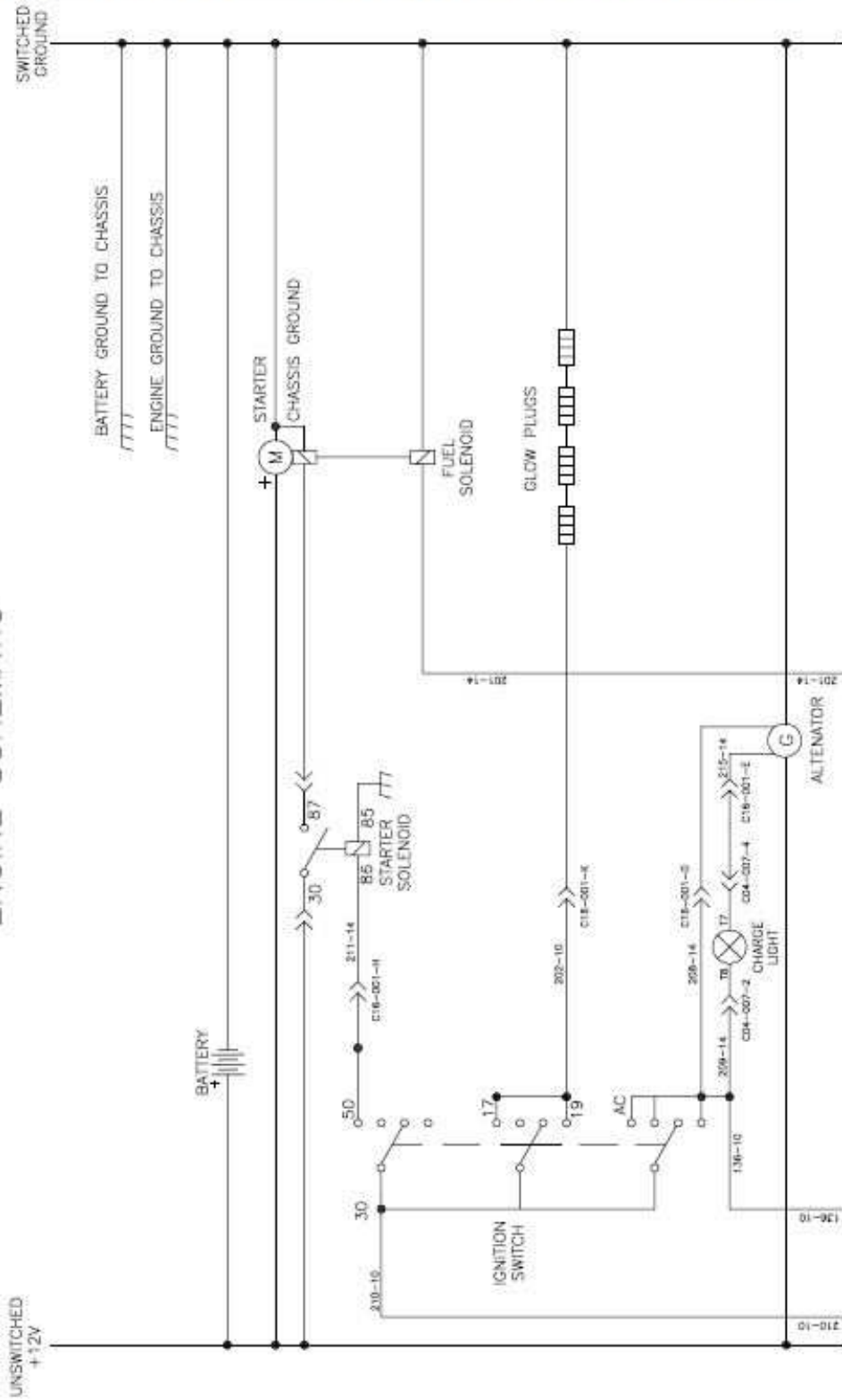

Vacuum Diesel Engine Schematic

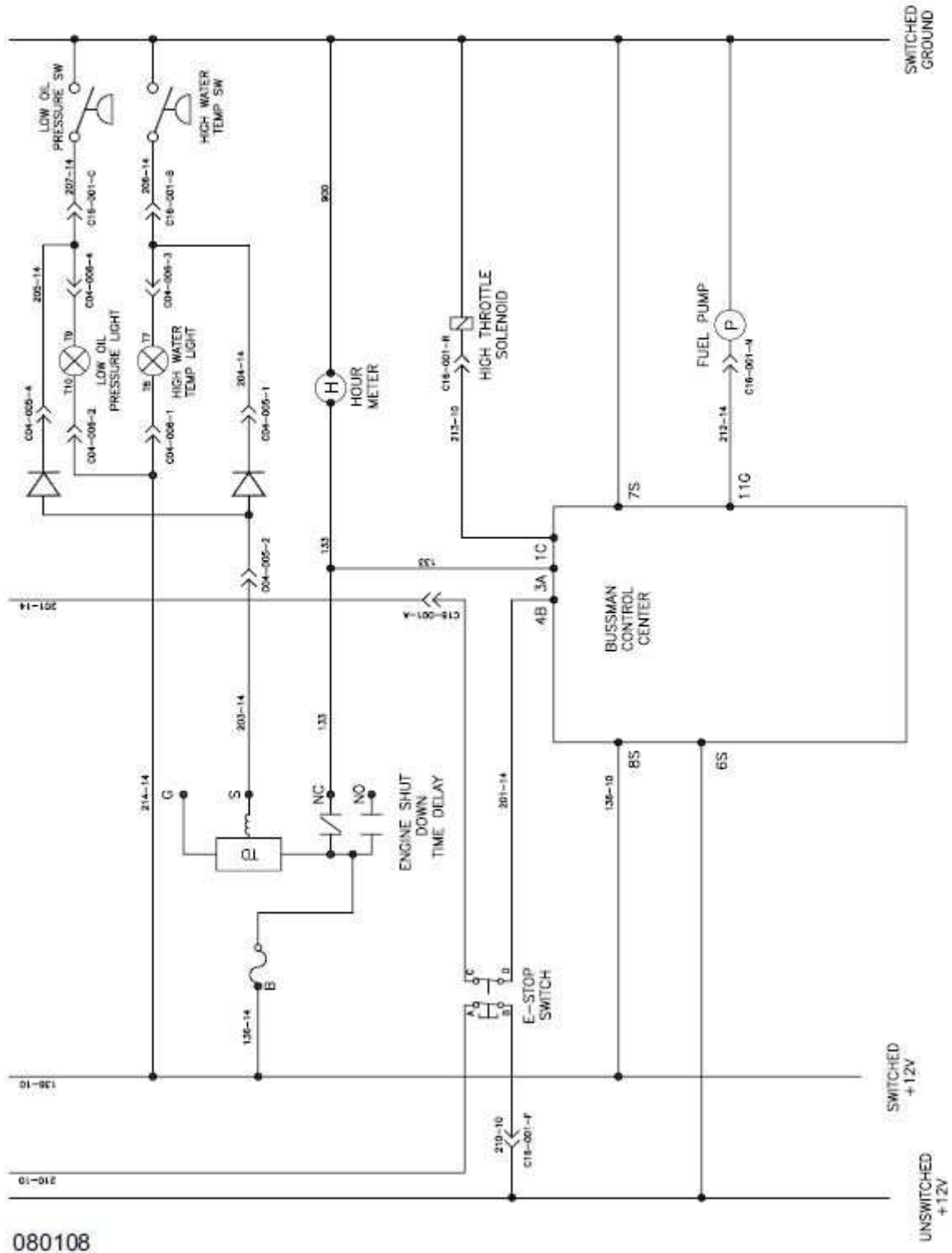

080108

Vacuum Diesel Engine Schematic

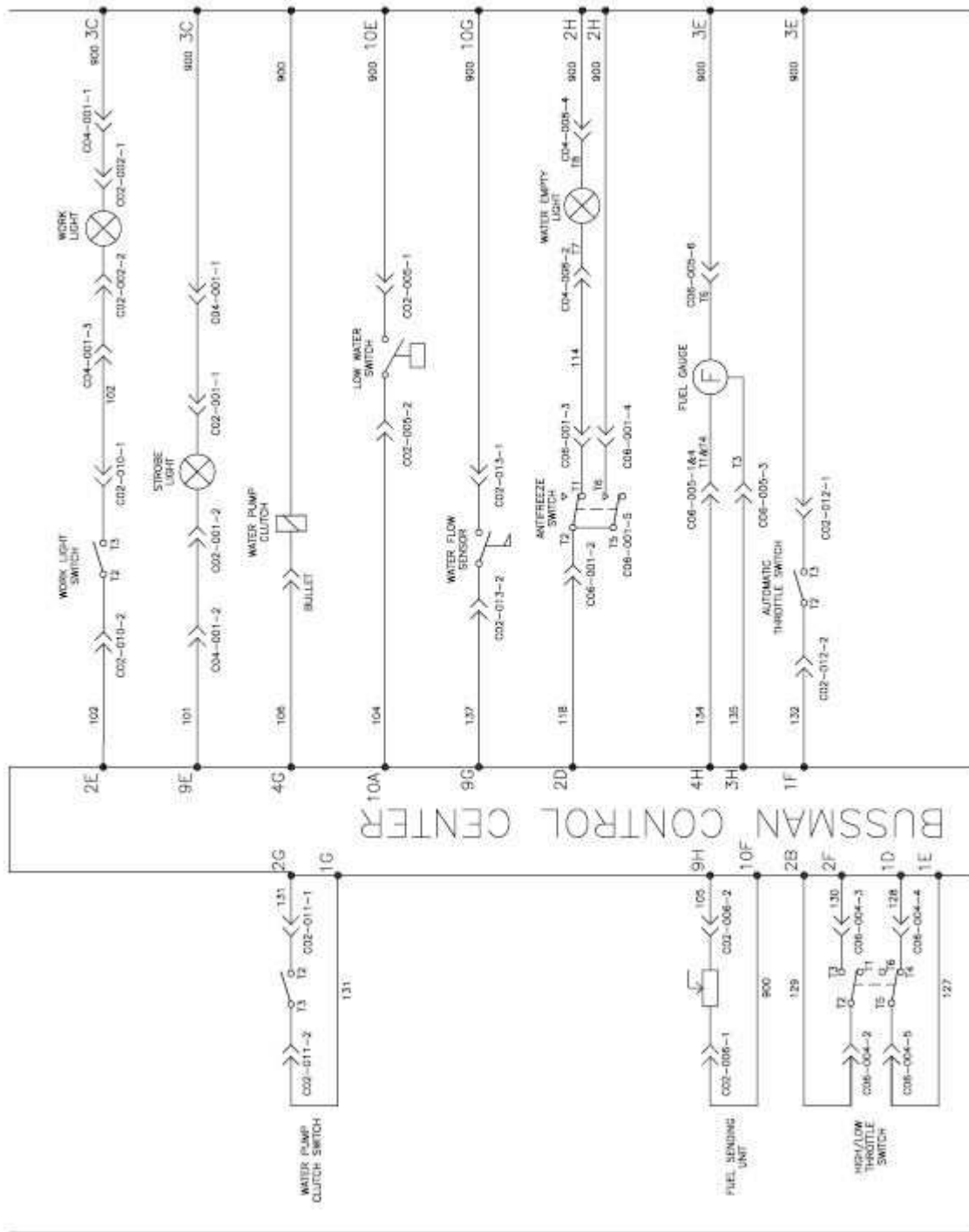

080108

Vacuum Diesel Engine Schematic

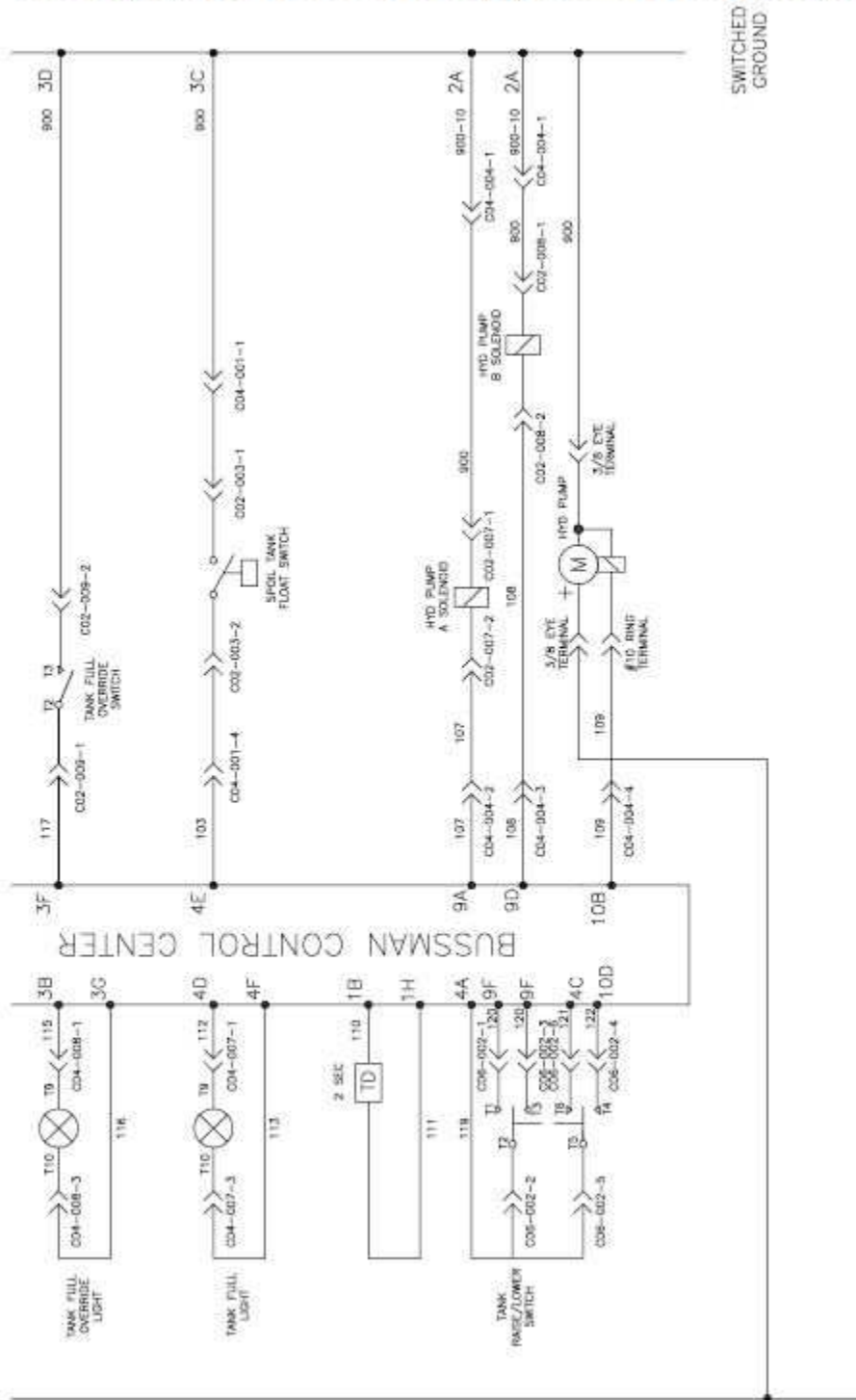

SWITCHED GROUND

080108

Vacuum Diesel Engine Schematic

BUSSMAN CONTROL CENTER
OPTIONS

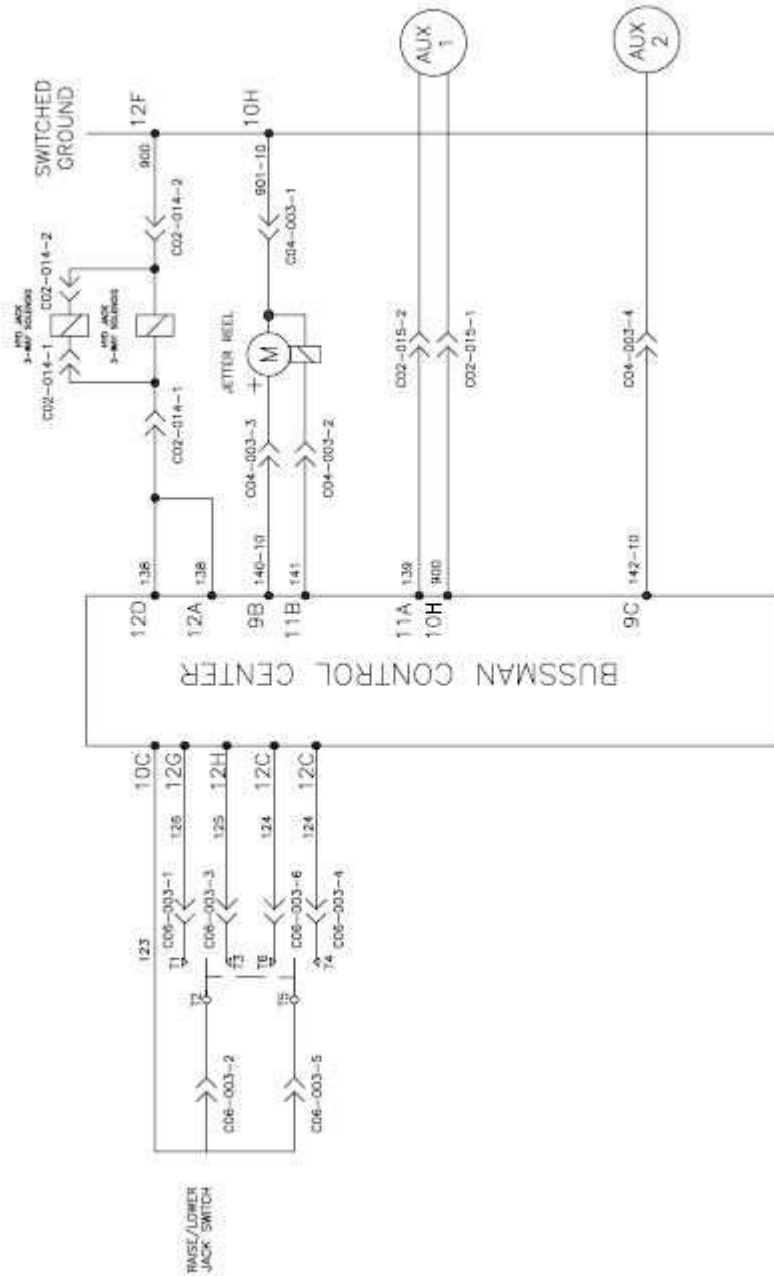

080108

ROOTS

Blowers Compressors Exhausters

Universal URAI-DSL

Contents

Information Summary	Troubleshooting
Safety Precautions	Inspection & Maintenance
Operating Limitations	Data
Lubrication	Assembly Drawings
Operation	Parts List

Do These Things To Get The Most From Your ROOTS™ blower

- **Make sure both driving and driven equipment is correctly lubricated before start-up. See LUBRICATION.**
- In event of trouble during installation or operation, do not attempt repairs of ROOTS furnished equipment. Notify ROOTS, giving all nameplate information plus an outline of operating conditions and a description of the trouble. Unauthorized attempts at equipment repair may void ROOTS warranty.
- Units out of warranty may be repaired or adjusted by the owner. Good inspection and maintenance practices should reduce the needs for repairs.

NOTE: Information in this manual is correct as of the date of publication. ROOTS reserves the right to make design or material changes without notice, and without obligation to make similar changes without notice, and without obligation to make similar changes on equipment of prior manufacture.



Lubrication

For Units with Splash Lubrication on Both Ends

Bearings and oil seals are lubricated by the action of the timing gears or oil slingers which dip into the main oil sumps

causing oil to splash directly on gears and into bearings and seals. A drain port is provided below each bearing to prevent an excessive amount of oil in the bearings. Seals located inboard of the bearings in each headplate effectively retain oil within the sumps. Any small leakage that may occur should the seals wear passes into a cavity in each vented headplate and is drained downward.

Oil sumps on each end of the blower are filled by removing top vent plugs, item (25), and filling until oil reaches the middle of the oil level sight gauge when the unit is not operating, Item (45 or 53), DO NOT FILL PAST THE MIDDLE OF THE SIGHT GLASS.

Initial filling of the sumps should be accomplished with the blower not operating, in order to obtain the correct oil level. Approximate oil quantities required for blowers of the various models and configurations are listed in Table 3. Use a good grade of industrial type non-detergent, rust inhibiting, anti-foaming oil and of correct viscosity per Table 2. ***ROOTS synthetic oil (Roots P/N 813-106-) is specified and recommended.** Roots does not recommend automotive type lubricants, as they are not formulated with the properties mentioned above.

The oil level may rise or fall on the gauge during operation, to an extent depending somewhat on oil temperature and blower speed.

Proper lubrication is usually the most important single consideration in obtaining maximum service life and satisfactory operation from the unit. Unless operating conditions are quite severe, a weekly check of oil level and necessary addition of lubricant should be sufficient. During the first week of operation, check the oil levels in the oil sumps about once a day, and watch for leaks. Replenish as necessary. Thereafter, an occasional check should be sufficient. It is recommended that the oil be changed after initial 100 hours of operation. Frequent oil changing is not necessary unless the blower is operated in a very dusty location.

Normal life expectancy of petroleum based oils is about 2000 hours with an oil temperature of about 180°F (82°C). As the oil temperature increases by increments of 15-18°F (8°C - 10°C), the life is reduced by half. Example: Oil temperatures of 210-216°F (99°C - 102°C) will produce life expectancy of 1/4 or 500 hours. Therefore, it is considered normal to have oil change periods of 500 hours with petroleum based oils.

Normal life expectancy of ROOTS™ Synthetic Oil is about 4000 to 8000 hours with an oil temperature of about 180°F (82°C). As the oil temperature increases by increments of 15-18°F (8°C - 10°C), the life is reduced by half. Example: Oil temperatures of 210-216°F (99°C - 102°C) will produce life expectancy of 1/4 or 1000 to 2000 hours.

NOTE: To estimate oil temperature, multiply the discharge temperature of the blower by 0.80. Example: if the discharge air temperature of the blower is 200° F, it is estimated that the oil temperature is 160° F.

*ROOTS™ Synthetic Oil & Grease is superior in performance to petroleum based products. It has high oxidation stability, excellent corrosion protection, extremely high film strength and low coefficient of friction. Typical oil change intervals are increased 2-3 times over petroleum based lubricants. Also, ROOTS™ Synthetic Oil is 100% compatible with petroleum based oils. Simply drain the oil in the blower and refill the reservoirs with ROOTS™ Synthetic Oil to maintain optimum performance of your ROOTS™ blower.

Operation

Before operating a blower under power for the first time, recheck the unit and the installation thoroughly to reduce the likelihood of avoidable troubles. Use the following procedure check list as a guide, but consider any other special conditions in the installation.

- Be certain that no bolts, tools, rags, or debris have been left in the blower air chamber or piping.
- If an outdoor intake without filter is used, be sure the opening is located so it cannot pick up dirt and is protected by a strong screen or grille. Use of the temporary protective screen as described under INSTALLATION is strongly recommended.
- Recheck blower leveling, drive alignment and tightness of all mounting bolts if installation is not recent. If belt drive is used, adjust belt tension correctly.
- Turn drive shaft by hand to make sure impellers still rotate without bumping or rubbing at any point.
- Ensure oil levels in the main oil sumps are correct.
- Check lubrication of driver. If it is an electric motor, be sure that power is available and that electrical overload devices are installed and workable.
- Open the manual unloading valve in the discharge air line. If a valve is in the inlet piping, be sure it is open.
- Bump blower a few revolutions with driver to check that direction of rotation agrees with arrow near blower shaft, and that both coast freely to a stop.

After the preceding points are cleared, blower is ready for trial operation under "no-load" conditions. The following procedure is suggested to cover this initial operation test period.

- a. Start blower, let it accelerate to full speed, then shut off. Listen for knocking sounds, both with power on and as speed slows down.
- b. After blower comes to a complete stop, repeat above, but let blower run 2 or 3 minutes. Check for noises, such as knocking sounds.
- c. After blower comes to a complete stop, operate blower for about 10 minutes unloaded. Check oil levels. Observe cylinder and headplate surfaces for development of hot spots such as burned paint, indicating impeller rubs. Be aware of any noticeable increase in vibration.

Assuming that all trials have been satisfactory, or that necessary corrections have been made, the blower should now have a final check run of at least one hour under normal operating conditions. After blower is restarted, gradually

close the discharge unloading valve to apply working pressure. At this point it is recommended that a pressure gauge or manometer be connected into the discharge line if not already provided, and that thermometers be in both inlet and discharge lines. Readings from these instruments will show whether pressure or temperature ratings of the blower are being exceeded.

During the final run, check operating conditions frequently and observe the oil levels at reasonable intervals. If excessive noise or local heating develops, shut down immediately and determine the cause. If either pressure rise or temperature rise across the blower exceeds the limit specified in this manual, shut down and investigate conditions in the piping system. Refer to the TROUBLESHOOTING CHECKLIST for suggestions on various problems that may appear.

The blower should now be ready for continuous duty operation at full load. During the first few days make periodic checks to determine whether all conditions remain steady, or at least acceptable. This may be particularly important if the blower is supplying air to a process system where conditions can vary. At the first opportunity, stop the blower and clean the temporary inlet protective screen. If no appreciable amount of debris has collected, the screen may be removed. See comments under INSTALLATION. At this same time, verify leveling, coupling alignment or belt tension, and mounting bolt tightness.

Should operating experience prove that blower capacity is a little too high for the actual air requirements, a small excess may be blown off continuously through the manual unloading or vent valve. Never rely on the pressure relief valve as an automatic vent. Such use may cause the discharge pressure to become excessive, and can also result in failure of the valve itself. If blower capacity appears to be too low, refer to the TROUBLESHOOTING CHECKLIST.

Vibration Assessment Criteria

With measurements taken at the bearing locations on the housings, see chart below for an appropriate assessment guide for rotary lobe blowers rigidly mounted on stiff foundations.

In general, blower vibration levels should be monitored on a regular basis and the vibration trend observed for progressive or sudden change in level. If such a change occurs, the cause should be determined through spectral analysis.

As shown on the chart below, the level of all pass vibration will determine the need to measure discrete frequency vibration levels and the action required.

All Pass Vibration (in/sec)	Discrete Frequency Vibration (in/sec)	Action
0.45 or less	N/R	Acceptable
Greater than 0.45 but 1.0 or less	0.45 or less @ any frequency	Acceptable
	Greater than 0.45 @ any frequency	Investigate
Greater than 1.0	Less than 1.0	Investigate
	Greater than 1.0	Investigate

Troubleshooting Checklist

Trouble	Item	Possible Cause	Remedy
No flow	1	Speed too low	Check by tachometer and compare with published performance
	2	Wrong rotation	Compare actual rotation with Figure 1 Change driver if wrong
	3	Obstruction in piping	Check piping, valves, silencer to assure open flow path
Low capacity	4	Speed too low	See item 1, if belt drive, check for slippage and readjust tension
	5	Excessive pressure rise	Check inlet vacuum and discharge pressure and compare with Published performance
	6	Obstruction in piping	See item 3
Excessive power	7	Excessive slip	Check inside of casing for worn or eroded surfaces causing excessive clearances
	8	Speed too high	Check speed and compare with published performance
	9	Excessive pressure rise	See item 5
	10	Impeller rubbing	Inspect outside of cylinder for high temperature areas, then check for impeller contact at these points. Correct blower mounting, drive alignment
Damage to bearings or gears	11	Scale, sludge, rust or product build up	Clean blower appropriately
	12	Inadequate lubrication	Check oil sump levels in gear and drive end headplates
	13	Excessive lubrication	Check oil levels. If correct, drain and refill with clean oil of recommended grade
	14	Excessive pressure rise	See item 5
	15	Coupling misalignment	Check carefully. Realign if questionable
Vibration	16	Excessive belt tension	Readjust for correct tension
	17	Misalignment	See item 15
	18	Impellers rubbing	See item 10
	19	Worn bearings/gears	Check gear backlash and condition of bearings, and replace as indicated
	20	Unbalanced or rubbing impeller	Scale or process material may build up on casing and impellers, or inside impellers. Remove build-up to restore original clearances and impeller balance
	21	Driver or blower loose	Tighten mounting bolts securely
	22	Piping resonances	Determine whether standing wave pressure pulsations are present in the piping
	23	Scale/sludge build-ups	Clean out interior of impeller lobes to restore dynamic balance
Driver stops, or will not start	24	Casing strain	Re-work piping alignment to remove excess strain
	25	Impeller stuck	Check for excessive hot spot on headplate or cylinder. See item 10. Look for defective shaft bearing and/or gear teeth
	26	Scale, sludge, rust or product build-up	Clean blower appropriately
Excessive breather	27	Broken seal	Replace seals
Blow-by or excessive oil leakage to vent area	28	Defective O-ring	Replace seals and O-ring
Excessive oil leakage in vent area	29	Defective/plugged breather	Replace breather and monitor oil leakage
	30	Oil level too high	Check sump levels in gear and drive headplates.
	31	Oil type or viscosity incorrect	Check oil to insure it meets recommendations. Drain then fill with clean oil of recommended grade.
	32	Blower running hot	Check blower operating conditions to ensure they are within the operating limitations defined in this manual.

Inspection & Maintenance: Universal RAI® series blowers

A good program of consistent inspection and maintenance is the most reliable method of minimizing repairs to a blower. A simple record of services and dates will help keep this work on a regular schedule. Basic service needs are:

- Lubrication
- Checking for hot spots
- Checking for increases or changes in vibration and noise
- Recording of operating pressures and temperatures

Above all, a blower must be operated within its specified rating limits, to obtain satisfactory service life.

A newly installed blower should be checked often during the first month of full-time operation. Attention there after may be less frequent assuming satisfactory performance.

Lubrication is normally the most important consideration and weekly checks of lubricant levels in the gearbox and bearing reservoirs should be customary. Complete oil change schedules are discussed under **LUBRICATION**.

Driver lubrication practices should be in accordance with the manufacturer's instructions. If direct connected to the blower through a lubricated type coupling, the coupling should be checked and greased each time blower oil is changed. This will help reduce wear and prevent unnecessary vibration. In a belted drive system, check belt tension periodically and inspect for frayed or cracked belts.

In a new, and properly installed, unit there is no contact between the two impellers, or between the impellers and cylinder or headplates. Wear is confined to the bearings (which support and locate the shafts) the oil seals, and the timing gears. All are lubricated and wear should be minimal if clean oil of the correct grade is always used. Seals are subject to deterioration as well as wear, and may require replacement at varying periods.

Shaft bearings are designed for optimum life under average conditions with proper lubrication and are critical to the service life of the blower. Gradual bearing wear may allow a shaft position to change slightly, until rubbing develops between impeller and casing. This will cause spot heating, which can be detected by observing these surfaces. Sudden bearing failure is usually more serious. Since the shaft and impeller are no longer supported and properly located, extensive general damage to the blower casing and gears is likely to occur.

Oil seals should be considered expendable items, to be replaced whenever drainage from the headplate vent cavity becomes excessive or when the blower is disassembled for

any reason. Some oil seal leakage may occur since an oil film under the lip is required for proper operation. Periodically leaked oil should be wiped off from surfaces. Minor seal leakage should not be considered as indicating seal replacement.

Timing gear wear, when correct lubrication is maintained, should be negligible. Gear teeth are cut to provide the correct amount of backlash, and gears correctly mounted on the shafts will accommodate a normal amount of tooth wear without permitting contact between lobes of the two impellers. However, too high an oil level will cause churning and excessive heating. This is indicated by unusually high temperature at the bottom of the gear housing. Consequent heating of the gears will result in loss of tooth-clearance, backlash and rapid wear of the gear teeth usually will develop. Continuation of this tooth wear will eventually produce impeller contacts (knocking), and from this point serious damage will be unavoidable if blower operation is continued. A similar situation can be produced suddenly by gear tooth fracture, which is usually brought on by sustained overloading or momentary shock loads.

Problems may also develop from causes other than internal parts failure. Operating clearances within a blower are only a few thousandths of an inch. This makes it possible for impeller interference or casing rubs to result from shifts in the blower mounting, or from changes in piping support. If this type of trouble is experienced, and the blower is found to be clean, try removing mounting strains. Loosen blower mounting bolts and reset the leveling and drive alignment. Then tighten mounting again, and make sure that all piping meets blower connections accurately and squarely. Foreign materials in the blower will also cause trouble, which can only be cured by disconnecting the piping and thoroughly cleaning the blower interior.

A wide range of causes & solutions for operating troubles are covered in the **TROUBLE SHOOTING CHECKLIST**. The remedies suggested should be performed by qualified mechanics with a good background. Major repairs generally are to be considered beyond the scope of maintenance, and should be referred to an authorized Roots distributor.

Warranty failures should not be repaired at all, unless specific approval has been obtained through Roots before starting work. Unauthorized disassembly within the warranty period may void the warranty.

Figure 2 - Allowable Overhung Loads for V-Belt Drives Universal RAI®/URAI®-DSL Units

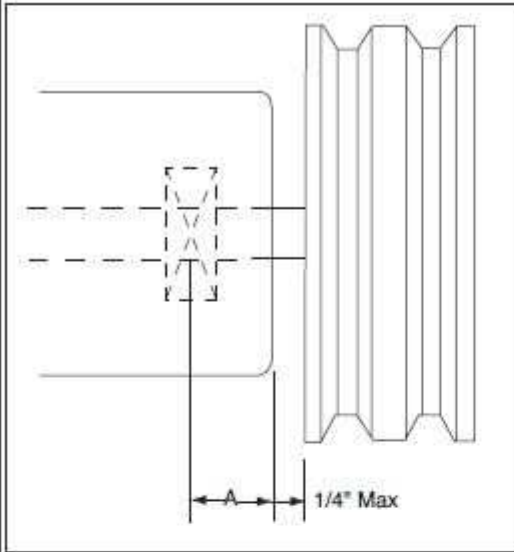

$$\text{Belt Pull lbs} = \frac{252100 \cdot \text{Motor HP}}{\text{Blower RPM} \cdot \text{Sheave Diameter}}$$

$$\text{Shaft Load (lb.in)} = \text{Belt Pull} \cdot \left(A + \frac{1}{4} + \frac{\text{Sheave Width}}{2} \right)$$

Frame Size	Dimension "A"	Max Allowable Shaft Load (lb-in)	Min Sheave Diameter
59	1.13	1,325	6.00

NOTE:

Arc of sheave belt contact on the smaller sheave not to be less than 170°

Driver to be installed on the inlet side for vertical units, and on the drive shaft side for horizontal units.

Roots recommends the use of two or more 3V, 5V or 8V matched set or banded belts and sheaves.

Specified Lubricants

ROOTS Synthetic Oil: ISO-VG-320 Grade

	Part Number
Quart	13106004
Gallon	13106005
Case (12 qts)	13106007

ROOTS Synthetic Oil: ISO-VG-220 Grade

	Part Number
Quart	13106001
Gallon	13106002
Case (12 qts)	13106008

ROOTS Synthetic Oil: ISO-VG-150 Grade

	Part Number
Quart	13106020
Gallon	13106021
Case (12 qts)	13106023
5 Gallon Pail	13106022
55 Gallon Drum	13106025

Drive End Breather Orientation for URA-DSL blowers with Oil Lube

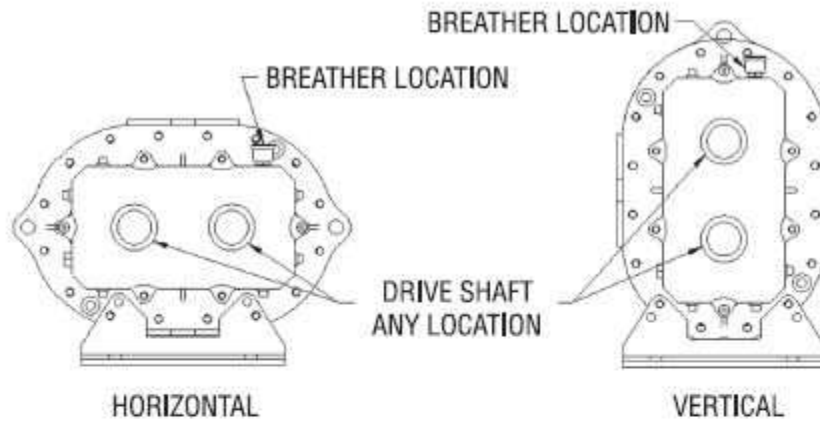

URAI DSL BREATHER ORIENTATION

Table 1 - URAI, URAI-DSL Blowers,
Maximum Allowable Operating Conditions

Frame Size	Gear Diameter (Inch)	Speed RPM	Temp. Rise Deg F (Deg C)	Delta Pressure PSI (mbar)	Inlet Vacuum INHG (mbar)
59	5	2,850	225 (125)	7 (483)	15 (500)

Table 2 - Recommended Oil Grades

Ambient Temperature °F (°C)	ISO Viscosity No.
Above 90° (32°)	320
32° to 90° (0° to 32°)	220
0° to 32° (-18° to 0°)	150
Below 0° (-18°)	100

Ambient temperature is defined as the temperature of the space in which the blower and drive are located.

Table 3 - Approximate Oil Sump Capacities

These capacities are provided to assist in stocking the correct amount of oil. Exact sump capacities may differ slightly. See "Lubrication" section for proper filling instructions.

URAI-DSL Splash Lubricated Blowers

Frame Size	Gear End Capacity Fl. Oz (Liters)	Drive End Capacity Fl. Oz. (Liters)
59	27.6 (.82)	14.8 (.44)

Basic Connection & Drive Shaft Information

URAI DSL AIR BLOWERS (with Dual Splash Lubrication DSL)

BOM#	FRAME SIZE	INLET/DISCHARGE CONN.	SHAFT DIAMETER	BARE WEIGHT
T30361020	59	4" NPT	1.125	209

Universal RAI air blowers include detachable mounting feet which permit vertical or horizontal installation. The units are center flanged for rotation in either direction. The bearings on the URAI are grease lubricated on the drive end and splash lubricated on the gear end. The URAI-DSL is splash lubricated on BOTH ends.

Table 2 - Recommended Oil Grades

Ambient Temperature °F (°C)	ISO Viscosity No.
Above 90° (32°)	320
32° to 90° (0° to 32°)	220
0° to 32° (-18° to 0°)	150
Below 0° (-18°)	100

Ambient temperature is defined as the temperature of the space in which the blower and drive are located.

Table 3 - Approximate Oil Sump Capacities

These capacities are provided to assist in stocking the correct amount of oil. Exact sump capacities may differ slightly. See "Lubrication" section for proper filling instructions.

URAI-DSL Splash Lubricated Blowers

Frame Size	Gear End Capacity Fl. Oz (Liters)	Drive End Capacity Fl. Oz. (Liters)
59	27.6 (.82)	14.8 (.44)

Basic Connection & Drive Shaft Information

URAI DSL AIR BLOWERS (with Dual Splash Lubrication DSL)

BOM#	FRAME SIZE	INLET/DISCHARGE CONN.	SHAFT DIAMETER	BARE WEIGHT
T30361020	59	4" NPT	1.125	209

Universal RAI air blowers include detachable mounting feet which permit vertical or horizontal installation. The units are center fired for rotation in either direction. The bearings on the URAI are grease lubricated on the drive end and splash lubricated on the gear end. The URAI-DSL is splash lubricated on BOTH ends.

PAGE LEFT BLANK

WARRANTY RETURN GOODS POLICY

LIMITED WARRANTY

The Manufacturer warrants its products to be free from defects in material and workmanship for a period of twelve months from the date of shipment from the factory. The Manufacturer shall not be responsible for any damage resulting to or caused by its products by reason of installation, improper storage, unauthorized service, alteration of the products, neglect or abuse, or use of the product in a manner inconsistent with its design. The warranty does not extend to any component parts not manufactured by Manufacturer; however, Manufacturer's warranty herein shall not limit any warranties made by manufacturers of component parts which extend to Buyer.

Claims for defects in material and workmanship shall be made in writing to Manufacturer within ten days of discovery of defect. Manufacturer may either send a service representative or have the product returned to its factory at Buyer's expense for inspection. Upon notification of defect, Manufacturer will issue a return goods authorization number to Buyer. The return goods authorization number must accompany the product returned. If judged by the Manufacturer to be defective in material or workmanship, the product will be replaced or repaired at the option of the Manufacturer, free from all charges except authorized transportation. Buyer shall be responsible for all maintenance services consisting of lubrication and cleaning of equipment, replacing expandable parts, making minor adjustments, and performing operating checks, all in accordance with procedures outlined in Manufacturer's maintenance literature.

THE FOREGOING WARRANTY IS IN LIEU OF ALL OTHER WARRANTIES AND NO REPRESENTATIONS, GUARANTEES, OR WARRANTIES, EXPRESS OR IMPLIED, (INCLUDING BUT NOT LIMITED TO A WARRANTY OF MERCHANTABILITY OR FITNESS FOR A PARTICULAR PURPOSE), ARE MADE BY THE MANUFACTURER IN CONNECTION WITH THE MANUFACTURE OR SALE OF ITS PRODUCTS. NO EMPLOYEE, DISTRIBUTOR, OR REPRESENTATIVE IS AUTHORIZED TO CHANGE THIS WARRANTY ON BEHALF OF MANUFACTURER.

THE REMEDIES OF BUYER SET FORTH HEREIN ARE EXCLUSIVE AND ARE IN LIEU OF ALL OTHER REMEDIES. THE LIABILITY OF MANUFACTURER WHETHER IN CONTRACT, TORT, UNDER ANY WARRANTY, OR

OTHERWISE SHALL NOT EXTEND BEYOND ITS OBLIGATION TO REPAIR OR REPLACE, AT ITS OPTION ANY PRODUCT OR PART FOUND BY MANUFACTURER TO BE DEFECTIVE IN MATERIAL OR WORKMANSHIP. MANUFACTURER SHALL NOT BE LIABLE FOR COST OF INSTALLATION AND/OR REMOVAL OR BE RESPONSIBLE FOR DIRECT, INDIRECT, SPECIAL OR CONSEQUENTIAL DAMAGES OF ANY NATURE.

GENERAL RETURNS OF MERCHANDISE

1. All returns must be pre-authorized
 - A. Please call our parts department for an RGA number
 - B. Please include RGA number on the outside of box
 - C. Include any required paper work or special instructions
 - D. Items returned without an RGA number will not be accepted
2. All returns are subject to a 20% restock charge.
3. Special items are non-returnable
 - A. Non-stock parts
 - B. Custom parts
 - C. If you are unsure about a parts status when ordering, ask your McLaughlin representative if the item fits on of the above conditions.
4. Items must be returned within thirty days of original order date.
5. Items not returned within 30 days from the date of RGA is issued will not be accepted.
6. The item(s) must be in new condition. Used item(s) are not returnable.

FOR SCHEMATICS SEE: www.mclaughlinunderground

